

ELEMENTARY LECTURES
ON
ELECTRIC DISCHARGES, WAVES
AND IMPULSES,
AND
OTHER TRANSIENTS

BY
CHARLES PROTEUS STEINMETZ, A.M., PH.D.
Past President, American Institute of Electrical Engineers

SECOND EDITION
REVISED AND ENLARGED

McGRAW-HILL BOOK COMPANY, INC.
239 WEST 39TH STREET, NEW YORK
6 BOUVERIE STREET, LONDON, E. C.
1914

PREFACE TO THE SECOND EDITION.

SINCE the issue of the first edition, in 1911, our knowledge of transients has greatly increased, and many of the phenomena, especially those of double energy transients and compound circuits, have been observed and studied on transmission systems to a considerable extent, and have corroborated the oscillographic records given in the previous edition.

Considerable work has been done on momentary short circuits of alternators, and the variable component of the self-inductive reactance recognized as a transient reactance resulting from the mutual induction of the armature with the field circuit.

Especially in the field of sustained or continual, and of cumulative oscillations, a large amount of information has been gathered. The practical importance of these continual and cumulative oscillations has been strongly impressed upon operating and designing engineers in recent years, usually in the most disagreeable manner by the destruction of high power, high voltage transformers. A chapter on these phenomena has therefore been added in the second edition.

CHARLES P. STEINMETZ, A.M., PH.D.

February, 1914.

PREFACE TO THE FIRST EDITION.

IN the following I am trying to give a short outline of those phenomena which have become the most important to the electrical engineer, as on their understanding and control depends the further successful advance of electrical engineering. The art has now so far advanced that the phenomena of the steady flow of power are well understood. Generators, motors, transforming devices, transmission and distribution conductors can, with relatively little difficulty, be calculated, and the phenomena occurring in them under normal conditions of operation predetermined and controlled. Usually, however, the limitations of apparatus and lines are found not in the normal condition of operation, the steady flow of power, but in the phenomena occurring under abnormal though by no means unfrequent conditions, in the more or less transient abnormal voltages, currents, frequencies, etc.; and the study of the laws of these transient phenomena, the electric discharges, waves, and impulses, thus becomes of paramount importance. In a former work, "Theory and Calculation of Transient Electric Phenomena and Oscillations," I have given a systematic study of these phenomena, as far as our present knowledge permits, which by necessity involves to a considerable extent the use of mathematics. As many engineers may not have the time or inclination to a mathematical study, I have endeavored to give in the following a descriptive exposition of the physical nature and meaning, the origin and effects, of these phenomena, with the use of very little and only the simplest form of mathematics, so as to afford a general knowledge of these phenomena to those engineers who have not the time to devote to a more extensive study, and also to serve as an introduction to the study of "Transient Phenomena." I have, therefore, in the following developed these phenomena from the physical conception of energy, its storage and readjustment, and extensively used as illustrations oscillograms of such electric discharges, waves, and impulses, taken on industrial electric circuits of all kinds, as to give the reader a familiarity

with transient phenomena by the inspection of their record on the photographic film of the oscillograph. I would therefore recommend the reading of the following pages as an introduction to the study of "Transient Phenomena," as the knowledge gained thereby of the physical nature materially assists in the understanding of their mathematical representation, which latter obviously is necessary for their numerical calculation and pre-determination.

The book contains a series of lectures on electric discharges, waves, and impulses, which was given during the last winter to the graduate classes of Union University as an elementary introduction to and "translation from mathematics into English" of the "Theory and Calculation of Transient Electric Phenomena and Oscillations." Hereto has been added a chapter on the calculation of capacities and inductances of conductors, since capacity and inductance are the fundamental quantities on which the transients depend.

In the preparation of the work, I have been materially assisted by Mr. C. M. Davis, M.E.E., who kindly corrected and edited the manuscript and illustrations, and to whom I wish to express my thanks.

CHARLES PROTEUS STEINMETZ.

October, 1911.

CONTENTS.

	PAGE
LECTURE I. — NATURE AND ORIGIN OF TRANSIENTS.....	1
1. Electric power and energy. Permanent and transient phenomena. Instance of permanent phenomenon; of transient; of combination of both. Transient as intermediary condition between permanents.	
2. Energy storage in electric circuit, by magnetic and dielectric field. Other energy storage. Change of stored energy as origin of transient.	
3. Transients existing with all forms of energy: transients of railway car; of fan motor; of incandescent lamp. Destructive values. High-speed water-power governing. Fundamental condition of transient. Electric transients simpler, their theory further advanced, of more direct industrial importance.	
4. Simplest transients: proportionality of cause and effect. Most electrical transients of this character. Discussion of simple transient of electric circuit. Exponential function as its expression. Coefficient of its exponent. Other transients: deceleration of ship.	
5. Two classes of transients: single-energy and double-energy transients. Instance of car acceleration; of low-voltage circuit; of pendulum; of condenser discharge through inductive circuit. Transients of more than two forms of energy.	
6. Permanent phenomena usually simpler than transients. Reduction of alternating-current phenomena to permanents by effective values and by symbolic method. Nonperiodic transients.	
LECTURE II. — THE ELECTRIC FIELD.....	10
7. Phenomena of electric power flow: power dissipation in conductor; electric field consisting of magnetic field surrounding conductor and electrostatic or dielectric field issuing from conductor. Lines of magnetic force; lines of dielectric force.	
8. The magnetic flux, inductance, inductance voltage, and the energy of the magnetic field.	
9. The dielectric flux, capacity, capacity current, and the energy of the dielectric field. The conception of quantity of electricity, electrostatic charge and condenser; the conception of quantity of magnetism.	
10. Magnetic circuit and dielectric circuit. Magnetomotive force, magnetizing force, magnetic field intensity, and magnetic density. Permeability. Magnetic materials.	

	PAGE
11. Electromotive force, electrifying force or voltage gradient. Dielectric field intensity and dielectric density. Specific capacity or permittivity. Velocity of propagation.	
12. Tabulation of corresponding terms of magnetic and of dielectric field. Tabulation of analogous terms of magnetic, dielectric, and electric circuit.	
LECTURE III. — SINGLE-ENERGY TRANSIENTS IN CONTINUOUS-CURRENT CIRCUITS.....	19
13. Single-energy transient represents increase or decrease of energy. Magnetic transients of low- and medium-voltage circuits. Single-energy and double-energy transients of capacity. Discussion of the transients of Φ , i , e , of inductive circuit. Exponential equation. Duration of the transient, time constant. Numerical values of transient of intensity 1 and duration 1. The three forms of the equation of the magnetic transient. Simplification by choosing the starting moment as zero of time.	
14. Instance of the magnetic transient of a motor field. Calculation of its duration.	
15. Effect of the insertion of resistance on voltage and duration of the magnetic transient. The opening of inductive circuit. The effect of the opening arc at the switch.	
16. The magnetic transient of closing an inductive circuit. General method of separation of transient and of permanent terms during the transition period.	
LECTURE IV. — SINGLE-ENERGY TRANSIENTS OF ALTERNATING-CURRENT CIRCUITS.....	30
17. Separation of current into permanent and transient component. Condition of maximum and of zero transient. The starting of an alternating current; dependence of the transient on the phase; maximum and zero value.	
18. The starting transient of the balanced three-phase system. Relation between the transients of the three phases. Starting transient of three-phase magnetic field, and its construction. The oscillatory start of the rotating field. Its independence of the phase at the moment of start. Maximum value of rotating-field transient, and its industrial bearing.	
19. Momentary short-circuit current of synchronous alternator, and current rush in its field circuit. Relation between voltage, load, magnetic field flux, armature reaction, self-inductive reactance, and synchronous reactance of alternator. Ratio of momentary to permanent short-circuit current.	
20. The magnetic field transient at short circuit of alternator. Its effect on the armature currents, and on the field current. Numerical relation between the transients of magnetic flux, armature currents, armature reaction, and field current. The starting transient of the armature currents. The transient full-frequency pulsation of the	

	PAGE
Modification for distributed capacity and inductance: the distance phase angle and the velocity of propagation; the time phase angle; the two forms of the equation of the line oscillation.	
29. Effective inductance and effective capacity, and the frequency of the line oscillation. The wave length. The oscillating-line section as quarter wave length.	
30. Relation between inductance, capacity, and frequency of propagation. Importance of this relation for calculation of line constants.	
31. The different frequencies and wave lengths of the quarter-wave oscillation; of the half-wave oscillation.	
32. The velocity unit of length. Its importance in compound circuits. Period, frequency, time, and distance angles, and the general expression of the line oscillation.	
 LECTURE VIII. — TRAVELING WAVES.....	88
33. The power of the stationary oscillation and its correspondence with reactive power of alternating currents. The traveling wave and its correspondence with effective power of alternating currents. Occurrence of traveling waves: the lightning stroke. The traveling wave of the compound circuit.	
34. The flow of transient power and its equation. The power-dissipation constant and the power-transfer constant. Increasing and decreasing power flow in the traveling wave. The general equation of the traveling wave.	
35. Positive and negative power-transfer constants. Undamped oscillation and cumulative oscillation. The arc as their source. The alternating-current transmission-line equation as special case of traveling wave of negative power-transfer constant.	
36. Coexistence and combination of traveling waves and stationary oscillations. Difference from effective and reactive alternating waves. Industrial importance of traveling waves. Their frequencies. Estimation of their effective frequency if very high.	
37. The impulse as traveling wave. Its equations. The wave front.	
 LECTURE IX. — OSCILLATIONS OF THE COMPOUND CIRCUIT.....	108
38. The stationary oscillation of the compound circuit. The time decrement of the total circuit, and the power-dissipation and power-transfer constants of its section. Power supply from section of low-energy dissipation to section of high-energy dissipation.	
39. Instance of oscillation of a closed compound circuit. The two traveling waves and the resultant transient-power diagram.	
40. Comparison of the transient-power diagram with the power diagram of an alternating-current circuit. The cause of power increase in the line. The stationary oscillation of an open compound circuit.	

41. Voltage and current relation between the sections of a compound oscillating circuit. The voltage and current transformation at the transition points between circuit sections.	
42. Change of phase angle at the transition points between sections of a compound oscillating circuit. Partial reflection at the transition point.	
LECTURE X. — CONTINUAL AND CUMULATIVE OSCILLATIONS.	119
43. Continual energy supply to the system as necessary cause, involving frequency transformation. Instance of arcing ground on transmission line. Recurrent and continuous continual oscillations. Their change and intermediate forms. Oscillograms of different types. Singing arc.	
44. Mechanism of energy supply to the continual oscillation by negative energy cycle. Hysteresis cycle of transient arc. Mechanism of energy supply and continuous and cumulative hunting of synchronous machines. Conditions of continual and of cumulative oscillations.	
45. Frequency of continual oscillation. Destructiveness of oscillation. Cumulative effect on insulation. Unlimited energy supply. Independence of frequency of continual oscillation from that of exciting cause.	
LECTURE XI. — INDUCTANCE AND CAPACITY OF ROUND PARALLEL CONDUCTORS.	128
46. Definition of inductance and of capacity. The magnetic and the dielectric field. The law of superposition of fields, and its use for calculation.	
47. Calculation of inductance of two parallel round conductors. External magnetic flux and internal magnetic flux.	
48. Calculation and discussion of the inductance of two parallel conductors at small distances from each other. Approximations and their practical limitations.	
49. Calculation of capacity of parallel conductors by superposition of dielectric fields. Reduction to electromagnetic units by the velocity of light. Relation between inductance, capacity, and velocity of propagation.	
50. Conductor with ground return, inductance, and capacity. The image conductor. Limitations of its application. Correction for penetration of return current in ground.	
51. Mutual inductance between circuits. Calculation of equation, and approximation.	
52. Mutual capacity between circuits. Symmetrical circuits and asymmetrical circuits. Grounded circuit.	
53. The three-phase circuit. Inductance and capacity of two-wire single-phase circuit, of single-wire circuit with ground return, and of three-wire three-phase circuit. Asymmetrical arrangement of three-phase circuit. Mutual inductance and mutual capacity with three-phase circuit.	

ELEMENTARY LECTURES ON ELECTRIC DISCHARGES, WAVES AND IMPULSES, AND OTHER TRANSIENTS.

LECTURE I.

NATURE AND ORIGIN OF TRANSIENTS.

1. Electrical engineering deals with electric energy and its flow, that is, electric power. Two classes of phenomena are met: permanent and transient phenomena. To illustrate: Let G in Fig. 1 be a direct-current generator, which over a circuit A connects to a load L , as a number of lamps, etc. In the generator G , the line A , and the load L , a current i flows, and voltages e

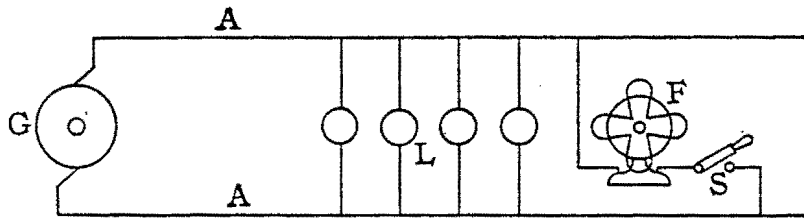

Fig. 1.

exist, which are constant, or permanent, as long as the conditions of the circuit remain the same. If we connect in some more lights, or disconnect some of the load, we get a different current i' , and possibly different voltages e' ; but again i' and e' are permanent, that is, remain the same as long as the circuit remains unchanged.

Let, however, in Fig. 2, a direct-current generator G be connected to an electrostatic condenser C . Before the switch S is closed, and therefore also in the moment of closing the switch, no current flows in the line A . Immediately after the switch S is closed, current begins to flow over line A into the condenser C , charging this condenser up to the voltage given by the generator. When the

condenser C is charged, the current in the line A and the condenser C is zero again. That is, the permanent condition before closing the switch S , and also some time after the closing of the switch, is zero current in the line. Immediately after the closing of the switch, however, current flows for a more or less short time. With the condition of the circuit unchanged: the same generator voltage, the switch S closed on the same circuit, the current nevertheless changes, increasing from zero, at the moment of closing the switch S , to a maximum, and then decreasing again to zero, while the condenser charges from zero voltage to the generator voltage. We then here meet a transient phenomenon, in the charge of the condenser from a source of continuous voltage.

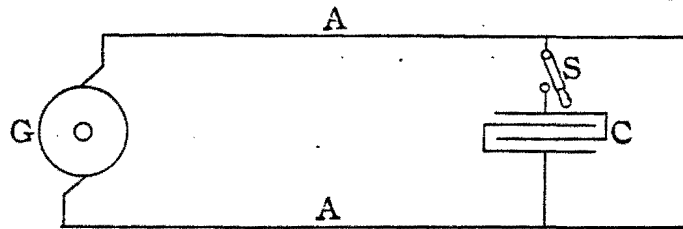

Fig. 2.

Commonly, transient and permanent phenomena are superimposed upon each other. For instance, if in the circuit Fig. 1 we close the switch S connecting a fan motor F , at the moment of closing the switch S the current in the fan-motor circuit is zero. It rapidly rises to a maximum, the motor starts, its speed increases while the current decreases, until finally speed and current become constant; that is, the permanent condition is reached.

The transient, therefore, appears as intermediate between two permanent conditions: in the above instance, the fan motor disconnected, and the fan motor running at full speed. The question then arises, why the effect of a change in the conditions of an electric circuit does not appear instantaneously, but only after a transition period, requiring a finite, though frequently very short, time.

2. Consider the simplest case: an electric power transmission (Fig. 3). In the generator G electric power is produced from mechanical power, and supplied to the line A . In the line A some of this power is dissipated, the rest transmitted into the load L , where the power is used. The consideration of the electric power

is the phenomenon by which the circuit readjusts itself to the change of stored energy. It may thus be said that the permanent phenomena are the phenomena of electric power, the transients the phenomena of electric energy.

3. It is obvious, then, that transients are not specifically electrical phenomena, but occur with all forms of energy, under all conditions where energy storage takes place.

Thus, when we start the motors propelling an electric car, a transient period, of acceleration, appears between the previous permanent condition of standstill and the final permanent condition of constant-speed running; when we shut off the motors, the permanent condition of standstill is not reached instantly, but a transient condition of deceleration intervenes. When we open the water gates leading to an empty canal, a transient condition of flow and water level intervenes while the canal is filling, until the permanent condition is reached. Thus in the case of the fan motor in instance Fig. 1, a transient period of speed and mechanical energy appeared while the motor was speeding up and gathering the mechanical energy of its momentum. When turning on an incandescent lamp, the filament passes a transient of gradually rising temperature.

Just as electrical transients may, under certain conditions, rise to destructive values; so transients of other forms of energy may become destructive, or may require serious consideration, as, for instance, is the case in governing high-head water powers. The column of water in the supply pipe represents a considerable amount of stored mechanical energy, when flowing at velocity, under load. If, then, full load is suddenly thrown off, it is not possible to suddenly stop the flow of water, since a rapid stopping would lead to a pressure transient of destructive value, that is, burst the pipe. Hence the use of surge tanks, relief valves, or deflecting nozzle governors. Inversely, if a heavy load comes on suddenly, opening the nozzle wide does not immediately take care of the load, but momentarily drops the water pressure at the nozzle, while gradually the water column acquires velocity, that is, stores energy.

The fundamental condition of the appearance of a transient thus is such a disposition of the stored energy in the system as differs from that required by the existing conditions of the system; and any change of the condition of a system, which requires a

change of the stored energy, of whatever form this energy may be, leads to a transient.

Electrical transients have been studied more than transients of other forms of energy because:

(a) Electrical transients generally are simpler in nature, and therefore yield more easily to a theoretical and experimental investigation.

(b) The theoretical side of electrical engineering is further advanced than the theoretical side of most other sciences, and especially:

(c) The destructive or harmful effects of transients in electrical systems are far more common and more serious than with other forms of energy, and the engineers have therefore been driven by necessity to their careful and extensive study.

4. The simplest form of transient occurs where the effect is directly proportional to the cause. This is generally the case in electric circuits, since voltage, current, magnetic flux, etc., are proportional to each other, and the electrical transients therefore are usually of the simplest nature. In those cases, however, where this direct proportionality does not exist, as for instance in inductive circuits containing iron, or in electrostatic fields exceeding the corona voltage, the transients also are far more complex, and very little work has been done, and very little is known, on these more complex electrical transients.

Assume that in an electric circuit we have a transient current, as represented by curve i in Fig. 4; that is, some change of circuit condition requires a readjustment of the stored energy, which occurs by the flow of transient current i . This current starts at the value i_1 , and gradually dies down to zero. Assume now that the law of proportionality between cause and effect applies; that is, if the transient current started with a different value, i_2 , it would traverse a curve i' , which is the same as curve i , except that all values are changed proportionally, by the ratio $\frac{i_2}{i_1}$; that is, $i' = i \times \frac{i_2}{i_1}$.

Starting with current i_1 , the transient follows the curve i ; starting with i_2 , the transient follows the proportional curve i' . At some time, t , however, the current i has dropped to the value i_2 , with which the curve i' started. At this moment t , the conditions in the first case, of current i , are the same as the conditions in

the second case, of current i' , at the moment t_1 ; that is, from t onward, curve i is the same as curve i' from time t_1 onward. Since

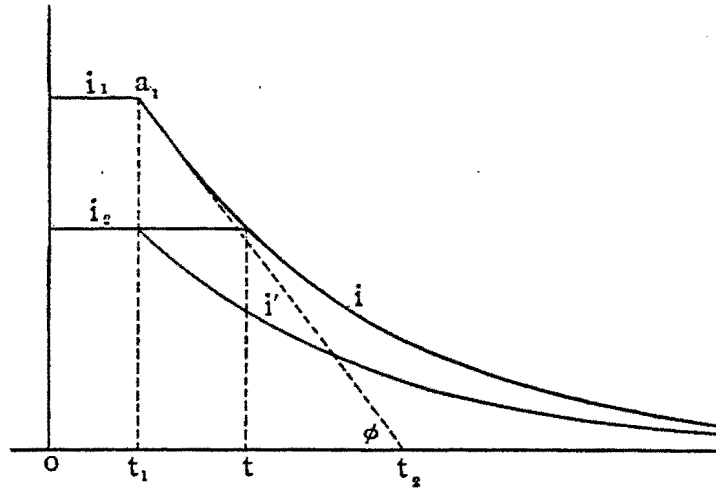

Fig. 4. — Curve of Simple Transient: Decay of Current.

i' is proportional to i , from any point t onward curve i is proportional to the same curve i from t_1 onward. At time t_1 , it is

$$\frac{di_2}{dt_1} = \frac{di_1}{dt_1} \times \frac{i_2}{i_1}.$$

But since $\frac{di_2}{dt_1}$ and i_2 at t_1 are the same as $\frac{di}{dt}$ and i at time t , it follows:

$$\frac{di}{dt} = \frac{di_1}{dt_1} \frac{i}{i_1},$$

or,

$$\frac{di}{dt} = -ci,$$

where $c = -\frac{1}{i_1} \frac{di_1}{dt} = \text{constant}$, and the minus sign is chosen, as $\frac{di}{dt}$ is negative.

As in Fig. 4:

$$\tan \phi = -\frac{di_1}{dt},$$

$$\overline{a_1 t_1} = i_1,$$

$$c = -\frac{1}{i_1} \frac{di_1}{dt} = \frac{\tan \phi}{\overline{a_1 t_1}} = \frac{1}{t_1 t_2};$$

that is, c is the reciprocal of the projection $T = \overline{t_1 t_2}$ on the zero line of the tangent at the starting moment of the transient.

Since

$$c = \frac{1}{T},$$

$$\frac{di}{i} = -cdt;$$

that is, the percentual change of current is constant, or in other words, in the same time, the current always decreases by the same fraction of its value, no matter what this value is.

Integrated, this equation gives:

$$\log i = -ct + C,$$

$$i = A\epsilon^{-ct},$$

or,

$$i = A\epsilon^{-\frac{t}{T}};$$

that is, the curve is the exponential.

The exponential curve thus is the expression of the simplest form of transient. This explains its common occurrence in electrical and other transients. Consider, for instance, the decay of radioactive substances: the radiation, which represents the decay, is proportional to the amount of radiating material; it is $\frac{dm}{dt} = cm$, which leads to the same exponential function.

Not all transients, however, are of this simplest form. For instance, the deceleration of a ship does not follow the exponential, but at high velocities the decrease of speed is a greater fraction of the speed than during the same time interval at lower velocities, and the speed-time curves for different initial speeds are not proportional to each other, but are as shown in Fig. 5. The reason is, that the frictional resistance is not proportional to the speed, but to the square of the speed.

5. Two classes of transients may occur:

1. Energy may be stored in one form only, and the only energy change which can occur thus is an increase or a decrease of the stored energy.

2. Energy may be stored in two or more different forms, and the possible energy changes thus are an increase or decrease of the total stored energy, or a change of the stored energy from one form to another. Usually both occur simultaneously.

An instance of the first case is the acceleration or deceleration

of a train, or a ship, etc.: here energy can be stored only as mechanical momentum, and the transient thus consists of an increase of the stored energy, during acceleration, or of a decrease, during

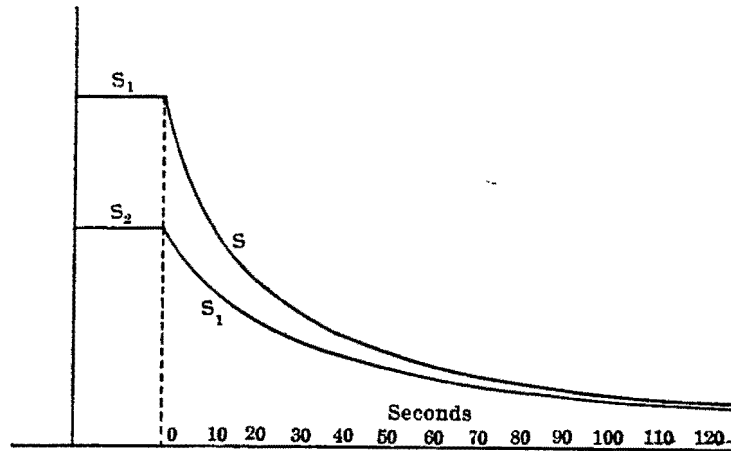

Fig. 5. — Deceleration of Ship.

deceleration. Thus also in a low-voltage electric circuit of negligible capacity, energy can be stored only in the magnetic field, and the transient represents an increase of the stored magnetic energy, during increase of current, or a decrease of the magnetic energy, during a decrease of current.

An instance of the second case is the pendulum, Fig. 6: with the weight at rest in maximum elevation, all the stored energy is

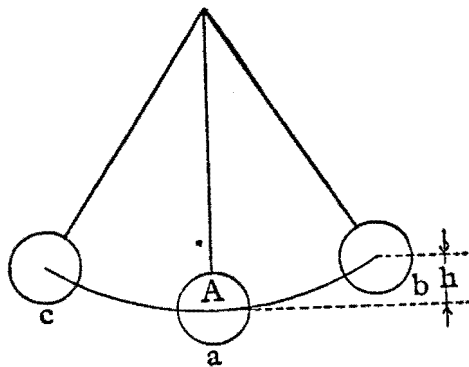

Fig. 6. — Double-energy Transient of Pendulum.

potential energy of gravitation. This energy changes to kinetic mechanical energy until in the lowest position, *a*, when all the potential gravitational energy has been either converted to kinetic mechanical energy or dissipated. Then, during the rise of the weight, that part of the energy which is not dissipated again changes to potential gravitational energy, at *c*, then back again to

kinetic energy, at *a*; and in this manner the total stored energy is gradually dissipated, by a series of successive oscillations or changes between potential gravitational and kinetic mechanical

to produce the magnetic field Φ of the current i , a voltage e' must be consumed in the circuit, which with the current i gives the power p , which supplies the stored energy w of the magnetic field Φ . This voltage e' is called the *inductance voltage*, or *voltage consumed by self-induction*.

Since no power is required to maintain the field, but power is required to produce it, the inductance voltage must be proportional to the rate of increase of the magnetic field:

$$e' = \frac{d\Phi}{dt}, \quad (3)$$

or by (1),

$$e' = L \frac{di}{dt}. \quad (4)$$

If i and therefore Φ decrease, $\frac{di}{dt}$ and therefore e' are negative; that is, p becomes negative, and power is returned into the circuit.

The energy supplied by the power p is

$$w = \int p \, dt,$$

or by (2) and (4),

$$w = \int Li' \, di;$$

hence

$$w = \frac{Li^2}{2}. \quad (5)$$

is the energy of the magnetic field

$$\Phi = Li$$

of the circuit.

9. Exactly analogous relations exist in the dielectric field.

The dielectric field, or *dielectric flux*, Ψ , is proportional to the voltage e , with a proportionality factor, C , which is called the *capacity of the circuit*:

$$\Psi = Ce. \quad (6)$$

The dielectric field represents stored energy, w . To produce it, power, p , must, therefore, be supplied by the circuit.

Since power is current times voltage:

$$p = i'e, \quad (7)$$

to produce the dielectric field Ψ of the voltage e , a current i' must be consumed in the circuit, which with the voltage e gives

are crowded together between the conductors, and the magnetic field consists of eccentric circles surrounding the conductors, as shown by the drawn lines in Fig. 9.

An *electrostatic*, or, as more properly called, *dielectric field*, issues from the conductors, that is, a *dielectric flux* passes between the conductors, which is measured by the *number of lines of dielectric force* Ψ . With a single conductor, the lines of dielectric force are radial straight lines, as shown dotted in Fig. 8. By the return conductor, they are crowded together between the conductors, and form arcs of circles, passing from conductor to return conductor, as shown dotted in Fig. 9.

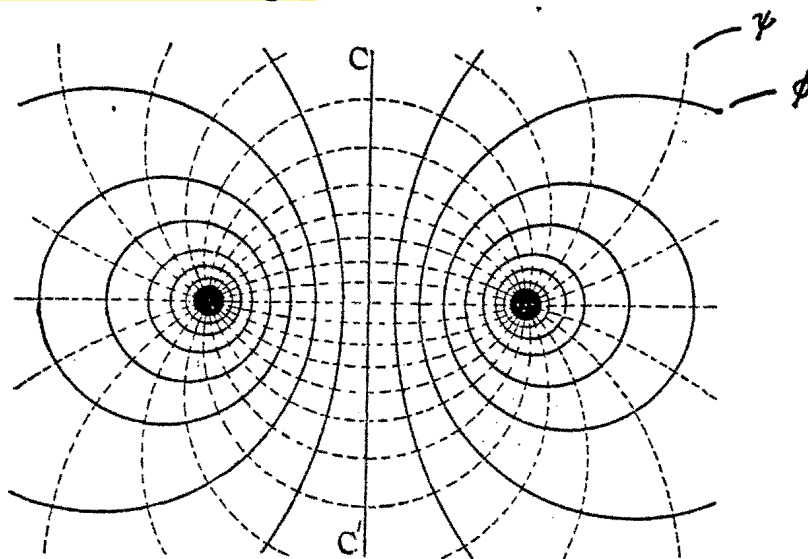

Fig. 9. — Electric Field of Circuit.

The magnetic and the dielectric field of the conductors both are included in the term *electric field*, and are the two components of the electric field of the conductor.

8. The magnetic field or *magnetic flux* of the circuit, Φ , is proportional to the current, i , with a proportionality factor, L , which is called the *inductance of the circuit*.

$$\Phi = Li.* \quad (1)$$

The magnetic field represents stored energy w . To produce it, power, p , must therefore be supplied by the circuit.

Since power is current times voltage:

$$p = e'i, \quad (2)$$

* $n\Phi$, if the flux Φ interlinks the circuit n fold.

the power p , which supplies the stored energy w of the dielectric field Ψ . This current i' is called the *capacity current*, or, wrongly, *charging current* or *condenser current*.

Since no power is required to maintain the field, but power is required to produce it, the capacity current must be proportional to the rate of increase of the dielectric field:

$$i' = \frac{d\Psi}{dt}, \quad (8)$$

or by (6),

$$i' = C \frac{de}{dt}. \quad (9)$$

If e and therefore Ψ decrease, $\frac{de}{dt}$ and therefore i' are negative; that is, p becomes negative, and power is returned into the circuit.

The energy supplied by the power p is

$$w = \int p dt, \quad (10)$$

or by (7) and (9),

$$w = \int C e de;$$

hence

$$w = \frac{C e^2}{2} \quad (11)$$

is the energy of the dielectric field

$$\Psi = C e$$

of the circuit.

As seen, the capacity current is the exact analogy, with regard to the dielectric field, of the inductance voltage with regard to the magnetic field; the representations in the electric circuit, of the energy storage in the field.

The dielectric field of the circuit thus is treated and represented in the same manner, and with the same simplicity and perspicuity, as the magnetic field, by using the same conception of lines of force.

Unfortunately, to a large extent in dealing with the dielectric fields the prehistoric conception of the electrostatic charge on the conductor still exists, and by its use destroys the analogy between the two components of the electric field, the magnetic and the

dielectric, and makes the consideration of dielectric fields unnecessarily complicated.

There obviously is no more sense in thinking of the capacity current as current which charges the conductor with a quantity of electricity, than there is of speaking of the inductance voltage as charging the conductor with a quantity of magnetism. But while the latter conception, together with the notion of a quantity of magnetism, etc., has vanished since Faraday's representation of the magnetic field by the lines of magnetic force, the terminology of electrostatics of many textbooks still speaks of electric charges on the conductor, and the energy stored by them, without considering that the dielectric energy is not on the surface of the conductor, but in the space outside of the conductor, just as the magnetic energy.

10. All the lines of magnetic force are closed upon themselves, all the lines of dielectric force terminate at conductors, as seen in Fig. 8, and the magnetic field and the dielectric field thus can be considered as a *magnetic circuit* and a *dielectric circuit*.

To produce a *magnetic flux* Φ , a *magnetomotive force* F is required. Since the magnetic field is due to the current, and is proportional to the current, or, in a coiled circuit, to the current times the number of turns, magnetomotive force is expressed in *current turns* or *ampere turns*.

$$F = ni. \quad (12)$$

If F is the m.m.f., l the length of the magnetic circuit, energized by F ,

$$f = \frac{F}{l} \quad (13)$$

is called the *magnetizing force*, or *magnetic gradient*, and is expressed in *ampere turns per cm.* (or industrially sometimes in ampere turns per inch).

In empty space, and therefore also, with very close approximation, in all nonmagnetic material, f ampere turns per cm. length of magnetic circuit produce $\mathcal{H} = 4\pi f 10^{-1}$ lines of magnetic force per square cm. section of the magnetic circuit. (Here the factor 10^{-1} results from the ampere being 10^{-1} of the absolute or cgs. unit of current.)

$$\mathcal{H} = 4\pi f 10^{-1} * \quad (14)$$

* The factor 4π is a survival of the original definition of the magnetic field intensity from the conception of the magnetic mass, since unit magnetic mass was defined as that quantity of magnetism which acts on an equal quantity at

is called the *magnetic-field intensity*. It is the *magnetic density*, that is, the number of lines of magnetic force per cm^2 , produced by the magnetizing force of f ampere turns per cm. in empty space.

The *magnetic density*, in lines of magnetic force per cm^2 , produced by the field intensity \mathcal{H} in any material is

$$\mathcal{B} = \mu\mathcal{H}, \quad (15)$$

where μ is a constant of the material, a "magnetic conductivity," and is called the *permeability*. $\mu = 1$ or very nearly so for most materials, with the exception of very few, the so-called *magnetic materials*: iron, cobalt, nickel, and some alloys and oxides of these metals and of manganese and chromium.

If then A is the section of the magnetic circuit, the total magnetic flux is

$$\Phi = A\mathcal{B}. \quad (16)$$

Obviously, if the magnetic field is not uniform, equations (13) and (16) would be correspondingly modified; f in (13) would be the average magnetizing force, while the actual magnetizing force would vary, being higher at the denser, and lower at the less dense, parts of the magnetic circuit:

$$f = \frac{dF}{dl}. \quad (17)$$

In (16), the magnetic flux Φ would be derived by integrating the densities \mathcal{B} over the total section of the magnetic circuit.

II. Entirely analogous relations exist in the dielectric circuit.

To produce a *dielectric flux* Ψ , an *electromotive force* e is required, which is measured in volts. The e.m.f. per unit length of the dielectric circuit then is called the *electrifying force* or the *voltage gradient*, and is

$$G = \frac{e}{l}. \quad (18)$$

unit distance with unit force. The unit field intensity, then, was defined as the field intensity at unit distance from unit magnetic mass, and represented by one line (or rather "tube") of magnetic force. The magnetic flux of unit magnetic mass (or "unit magnet pole") hereby became 4π lines of force, and this introduced the factor 4π into many magnetic quantities. An attempt to drop this factor 4π has failed, as the magnetic units were already too well established.

The factor 10^{-1} also appears undesirable, but when the electrical units were introduced the absolute unit appeared as too large a value of current as practical unit, and one-tenth of it was chosen as unit, and called "ampere."

This gives the average voltage gradient, while the actual gradient in an ununiform field, as that between two conductors, varies, being higher at the denser, and lower at the less dense, portion of the field, and is

$$G = \frac{de}{dl} \quad (19)$$

$$K = \frac{G}{4\pi}^*$$

then is the *dielectric-field intensity*, and

$$D = \kappa K \quad (20)$$

would be the *dielectric density*, where κ is a constant of the material, the electrostatic or dielectric conductivity, and is called the *specific capacity* or *permittivity*.

For empty space, and thus with close approximation for air and other gases,

$$\kappa = \frac{1}{v^2},$$

where

$$v = 3 \times 10^{10}$$

is the velocity of light.

It is customary, however, and convenient, to use the permittivity of empty space as unity: $\kappa = 1$. This changes the unit of dielectric-field intensity by the factor $\frac{1}{v^2}$, and gives: dielectric-field intensity,

$$K = \frac{G}{4\pi v^2}; \quad (21)$$

dielectric density,

$$D = \kappa K, \quad (22)$$

where $\kappa = 1$ for empty space, and between 2 and 6 for most solids and liquids, rarely increasing beyond 6, except in materials of appreciable electric conductivity.

The dielectric flux then is

$$\Psi = AD. \quad (23)$$

12. As seen, the dielectric and the magnetic fields are entirely analogous, and the corresponding values are tabulated in the following Table I.

* The factor 4π appears here in the denominator as the result of the factor 4π in the magnetic-field intensity \mathcal{H} , due to the relations between these quantities.

TABLE I.

Magnetic Field.	Dielectric Field.
Magnetic flux: $\Phi = Li 10^8$ lines of magnetic force.	Dielectric flux: $\Psi = Ce$ lines of dielectric force, or coulombs.
Inductance voltage: $e' = n \frac{d\Phi}{dt} 10^{-8} = L \frac{di}{dt}$ volts.	Capacity current: $i' = \frac{d\Psi}{dt} = C \frac{de}{dt}$ amperes.
Magnetic energy: $w = \frac{Li^2}{2}$ joules.	Dielectric energy: $w = \frac{Ce^2}{2}$ joules.
Magnetomotive force: $F = ni$ ampere turns.	Electromotive force: $e =$ volts.
Magnetizing force: $f = \frac{F}{l}$ ampere turns per cm.	Electrifying force or voltage gradient: $G = \frac{e}{l}$ volts per cm.
Magnetic-field intensity: $\mathcal{H} = 4\pi f 10^{-1}$ lines of magnetic force per cm ² .	Dielectric-field intensity: $K = \frac{G}{4\pi v^2} 10^9$ lines of dielectric force per cm ² , or coulombs per cm ² .
Magnetic density: $\mathcal{B} = \mu \mathcal{H}$ lines of magnetic force per cm ² .	Dielectric density: $D = \kappa K$ lines of dielectric force per cm ² , or coulombs per cm ² .
Permeability: μ	Permittivity or specific capacity: κ
Magnetic flux: $\Phi = A\mathcal{B}$ lines of magnetic force.	Dielectric flux: $\Psi = AD$ lines of dielectric force, or coulombs.
$v = 3 \times 10^{10} =$ velocity of light.	

The powers of 10, which appear in some expressions, are reduction factors between the absolute or cgs. units which are used for Φ , \mathcal{H} , \mathcal{B} , and the practical electrical units, used for other constants.

As the magnetic field and the dielectric field also can be considered as the magnetic circuit and the dielectric circuit, some analogy exists between them and the electric circuit, and in Table II the corresponding terms of the magnetic circuit, the dielectric circuit, and the electric circuit are given.

The magnetic flux is $\Phi_0 = 8 \times 10^6$, and with $4n$ total turns the total number of magnetic interlinkages thus is

$$4n\Phi_0 = 32n \times 10^6,$$

hence the inductance

$$L = \frac{4n\Phi_0 10^{-8}}{i_0} = \frac{.32n}{i_0} \text{ henrys.}$$

The field excitation is

$$ni_0 = 6000 \text{ ampere turns,}$$

hence

$$n = \frac{6000}{i_0}$$

hence

$$L = \frac{.32 \times 6000}{i_0^2} \text{ henrys,}$$

and

$$T = \frac{L}{r} = \frac{1920}{500} = 3.84 \text{ sec.}$$

That is, the stored magnetic energy could maintain full field excitation for nearly 4 seconds.

It is interesting to note that the duration of the field discharge does not depend on the voltage, current, or size of the machine, but merely on, first, the magnetic flux and m.m.f.,— which determine the stored magnetic energy,— and, second, on the excitation power, which determines the rate of energy dissipation.

15. Assume now that in the moment where the transient begins the resistance of the coil in Fig. 10 is increased, that is, the

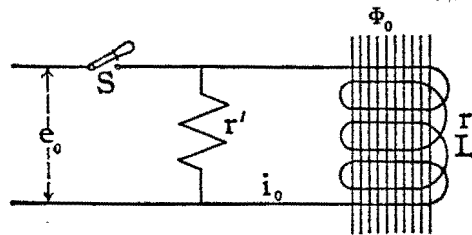

Fig. 12. — Magnetic Single-energy Transient.

coil is not short-circuited upon itself, but its circuit closed by a resistance r' . Such would, for instance, be the case in Fig. 12, when opening the switch S .

LECTURE II.

THE ELECTRIC FIELD.

7. Let, in Fig. 7, a generator G transmit electric power over line A into a receiving circuit M .

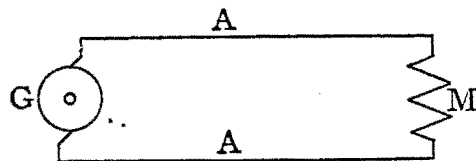

Fig. 7.

While power flows through the conductors A , power is consumed in these conductors by conversion into heat, represented by i^2r . This, however, is not all, but in the space surrounding the conductor certain phenomena occur: magnetic and electrostatic forces appear.

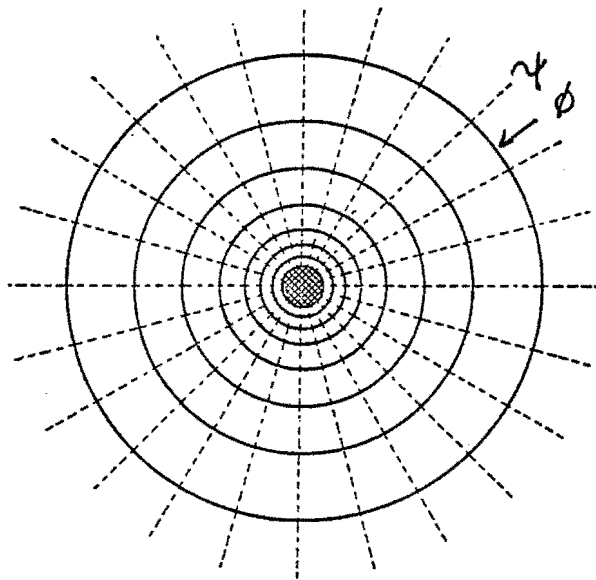

Fig. 8. — Electric Field of Conductor.

The conductor is surrounded by a *magnetic field*, or a magnetic flux, which is measured by the *number of lines of magnetic force* Φ . With a single conductor, the lines of magnetic force are concentric circles, as shown in Fig. 8. By the return conductor, the circles

LECTURE III.

SINGLE-ENERGY TRANSIENTS IN CONTINUOUS-CURRENT CIRCUITS.

13. The simplest electrical transients are those in circuits in which energy can be stored in one form only, as in this case the change of stored energy can consist only of an increase or decrease; but no surge or oscillation between several forms of energy can exist. Such circuits are most of the low- and medium-voltage circuits, — 220 volts, 600 volts, and 2200 volts. In them the capacity is small, due to the limited extent of the circuit, resulting from the low voltage, and at the low voltage the dielectric energy thus is negligible, that is, the circuit stores appreciable energy only by the magnetic field.

A circuit of considerable capacity, but negligible inductance, if of high resistance, would also give one form of energy storage only, in the dielectric field. The usual high-voltage capacity circuit, as that of an electrostatic machine, while of very small inductance, also is of very small resistance, and the momentary discharge currents may be very considerable, so that in spite of the very small inductance, considerable magnetic-energy storage may occur; that is, the system is one storing energy in two forms, and oscillations appear, as in the discharge of the Leyden jar.

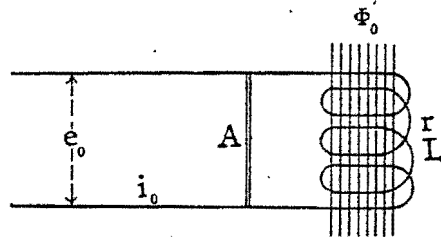

Fig. 10. — Magnetic Single-energy Transient.

Let, as represented in Fig. 10, a continuous voltage e_0 be impressed upon a wire coil of resistance r and inductance L (but negligible capacity). A current $i_0 = \frac{e_0}{r}$ flows through the coil and a magnetic field $\Phi_0 10^{-8} = \frac{Li_0}{n}$ interlinks with the coil. Assuming now that the voltage e_0 is suddenly withdrawn, without changing

the constants of the coil circuit, as for instance by short-circuiting the terminals of the coil, as indicated at A. With no voltage impressed upon the coil, and thus no power supplied to it, current i and magnetic flux Φ of the coil must finally be zero. However, since the magnetic flux represents stored energy, it cannot instantly vanish, but the magnetic flux must gradually decrease from its initial value Φ_0 , by the dissipation of its stored energy in the resistance of the coil circuit as i^2r . Plotting, therefore, the magnetic flux of the coil as function of the time, in Fig. 11A, the flux is constant and denoted by Φ_0 up to the moment of

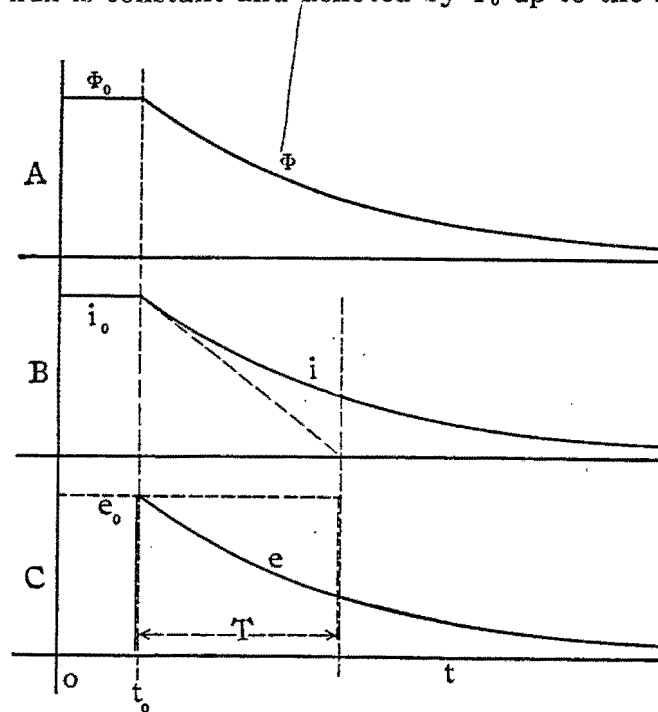

Fig. 11. — Characteristics of Magnetic Single-energy Transient.

time where the short circuit is applied, as indicated by the dotted line t_0 . From t_0 on the magnetic flux decreases, as shown by curve Φ . Since the magnetic flux is proportional to the current, the latter must follow a curve proportional to Φ , as shown in Fig. 11B. The impressed voltage is shown in Fig. 11C as a dotted line; it is e_0 up to t_0 , and drops to 0 at t_0 . However, since after t_0 a current i flows, an e.m.f. must exist in the circuit, proportional to the current.

$$e = ri.$$

This is the e.m.f. induced by the decrease of magnetic flux Φ , and is therefore proportional to the rate of decrease of Φ , that is, to $\frac{d\Phi}{dt}$. In the first moment of short circuit, the magnetic flux Φ still

has full value Φ_0 , and the current i thus also full value i_0 . Hence, at the first moment of short circuit, the induced e.m.f. e must be equal to e_0 , that is, the magnetic flux Φ must begin to decrease at such rate as to induce full voltage e_0 , as shown in Fig. 11C.

The three curves Φ , i , and e are proportional to each other, and as e is proportional to the rate of change of Φ , Φ must be proportional to its own rate of change, and thus also i and e . That is, the transients of magnetic flux, current, and voltage follow the law of proportionality, hence are simple exponential functions, as seen in Lecture I:

$$\left. \begin{aligned} \Phi &= \Phi_0 e^{-c(t-t_0)}, \\ i &= i_0 e^{-c(t-t_0)}, \\ e &= e_0 e^{-c(t-t_0)}. \end{aligned} \right\} \quad (1)$$

Φ , i , and e decrease most rapidly at first, and then slower and slower, but can theoretically never become zero, though practically they become negligible in a finite time.

The voltage e is induced by the rate of change of the magnetism, and equals the decrease of the number of lines of magnetic force, divided by the time during which this decrease occurs, multiplied by the number of turns n of the coil. The induced voltage e times the time during which it is induced thus equals n times the decrease of the magnetic flux, and the total induced voltage, that is, the area of the induced-voltage curve, Fig. 11C, thus equals n times the total decrease of magnetic flux, that is, equals the initial current i_0 times the inductance L :

$$\Sigma et = n\Phi_0 10^{-8} = Li_0. \quad (2)$$

Whatever, therefore, may be the rate of decrease, or the shape of the curves of Φ , i , and e , the total area of the voltage curve must be the same, and equal to $n\Phi_0 = Li_0$.

If then the current i would continue to decrease at its initial rate, as shown dotted in Fig. 11B (as could be caused, for instance, by a gradual increase of the resistance of the coil circuit), the induced voltage would retain its initial value e_0 up to the moment of time $t = t_0 + T$, where the current has fallen to zero, as

The duration of the transient now is

$$T = \frac{L}{r + r'},$$

that is, shorter in the same proportion as the resistance, and thereby the induced voltage is higher.

If $r' = \infty$, that is, no resistance is in shunt to the coil, but the circuit is simply opened, if the opening were instantaneous, it would be: $e_0' = \infty$; that is, an infinite voltage would be induced. That is, the insulation of the coil would be punctured and the circuit closed in this manner.

The more rapid, thus, the opening of an inductive circuit, the higher is the induced voltage, and the greater the danger of breakdown. Hence it is not safe to have too rapid circuit-opening devices on inductive circuits.

To some extent the circuit protects itself by an arc following the blades of the circuit-opening switch, and thereby retarding the circuit opening. The more rapid the mechanical opening of the switch, the higher the induced voltage, and further, therefore, the arc follows the switch blades and maintains the circuit.

16. Similar transients as discussed above occur when closing a circuit upon an impressed voltage, or changing the voltage, or the current, or the resistance or inductance of the circuit. A discussion of the infinite variety of possible combinations obviously would be impossible. However, they can all be reduced to the same simple case discussed above, by considering that several currents, voltages, magnetic fluxes, etc., in the same circuit add algebraically, without interfering with each other (assuming, as done here, that magnetic saturation is not approached).

If an e.m.f. e_1 produces a current i_1 in a circuit, and an e.m.f. e_2 produces in the same circuit a current i_2 , then the e.m.f. $e_1 + e_2$ produces the current $i_1 + i_2$, as is obvious.

If now the voltage $e_1 + e_2$, and thus also the current $i_1 + i_2$, consists of a permanent term, e_1 and i_1 , and a transient term, e_2 and i_2 , the transient terms e_2 , i_2 follow the same curves, when combined with the permanent terms e_1 , i_1 , as they would when alone in the circuit (the case above discussed). Thus, the preceding discussion applies to all magnetic transients, by separating the transient from the permanent term, investigating it separately, and then adding it to the permanent term.

TABLE II.

Magnetic Circuit.	Dielectric Circuit.	Electric Circuit.
Magnetic flux (magnetic current): Φ = lines of magnetic force.	Dielectric flux (dielectric current): Ψ = lines of dielectric force.	Electric current: i = electric current.
Magnetomotive force: $F = ni$ ampere turns.	Electromotive force: e = volts.	Voltage: e = volts.
Permeance: $M = \frac{\Phi}{.4\pi F}$.	Permittance or capacity: $C = \frac{\Psi}{e}$ farads.	Conductance: $g = \frac{i}{e}$ mhos.
Inductance: $L = \frac{n^2\Phi}{F} 10^{-8} = \frac{n\Phi}{i} 10^{-8}$ henry.	(Elastance): $\frac{1}{C} = \frac{e}{\Psi}$.	Resistance: $r = \frac{e}{i}$ ohms.
Reluctance: $R = \frac{F}{\Phi}$.	Dielectric energy: $w = \frac{Ce^2}{2} = \frac{e\Psi}{2}$ joules.	Electric power: $p = ri^2 = ge^2 = ei$ watts.
Magnetic energy: $w = \frac{Li^2}{2} = \frac{F\Phi}{2} 10^{-8}$ joules.	Dielectric density: $D = \frac{\Psi}{A} = \kappa K$ lines per cm ² .	Electric-current density: $I = \frac{i}{A} = \gamma G$ amperes per cm ² .
Magnetic density: $\mathfrak{B} = \frac{\Phi}{A} = \mu \mathfrak{C}$ lines per cm ² .	Dielectric gradient: $G = \frac{e}{l}$ volts per cm.	Electric gradient: $G = \frac{e}{l}$ volts per cm.
Magnetizing force: $f = \frac{F}{l}$ ampere turns per cm.	Dielectric-field intensity: $K = \frac{G}{4\pi v^2} 10^9$.	Conductivity: $\gamma = \frac{I}{G}$ mho-cm.
Magnetic-field intensity: $\mathfrak{C} = .4\pi f$.	Permittivity or specific capacity: $\kappa = \frac{D}{K}$.	Resistivity: $\rho = \frac{1}{\gamma} = \frac{G}{I}$ ohm-cm.
Permeability: $\mu = \frac{\mathfrak{B}}{\mathfrak{C}}$.	(Elastivity?): $\frac{1}{\kappa} = \frac{K}{D}$.	Specific power: $p_0 = \rho I^2 = G^2 = GI$ watts per cm ³ .
Reluctivity: $\rho = \frac{f}{\mathfrak{B}}$.	Specific dielectric energy: $w_0 = \frac{\kappa G^2}{4\pi v^2} 10^9 = \frac{GD}{2\pi v^2 \kappa D} 10^9 = \frac{GD}{2} 10^9$ joules per cm ³ .	
Specific magnetic energy: $w_0 = \frac{.4\pi \mu f^2}{2} = \frac{f\mathfrak{B}}{2} 10^{-8} = \frac{\mathfrak{C}\mathfrak{B}}{8\pi} 10^{-7}$ joules per cm ³ .		

sient, shown dotted in Fig. 15. Adding the transient current i_0 to the permanent current i_2 gives the total current during the transition period, which is shown in drawn line in Fig. 15.

As seen, the transient is due to the difference between the instantaneous value of the current i_1 which exists, and that of the current i_2 which should exist at the moment of change, and

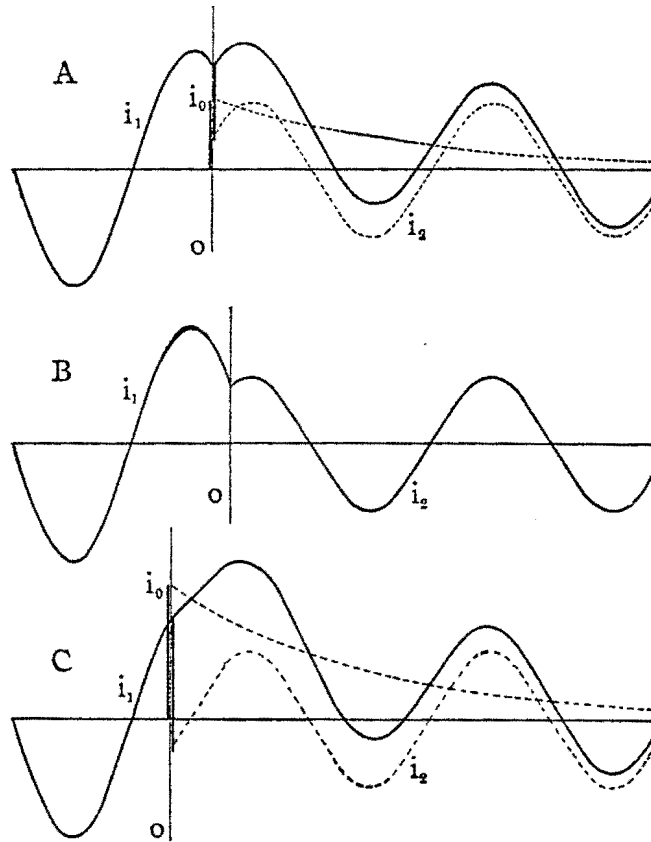

Fig. 15. — Single-energy Transient of Alternating-current Circuit.

thus is the larger, the greater the difference between the two currents, the previous and the after current. It thus disappears if the change occurs at the moment when the two currents i_1 and i_2 are equal, as shown in Fig. 15B, and is a maximum, if the change occurs at the moment when the two currents i_1 and i_2 have the greatest difference, as shown in Fig. 15C, that is, at a point one-quarter period or 90 degrees distant from the intersection of i_1 and i_2 .

half the value of i_3^0 , and are opposite in direction thereto. In any case, the three transients must be distributed on both sides of the zero line. This is obvious: if i_1' , i_2' , and i_3' are the instantaneous values of the permanent three-phase currents, in Fig. 17, the initial values of their transients are: $-i_1'$, $-i_2'$, $-i_3'$.

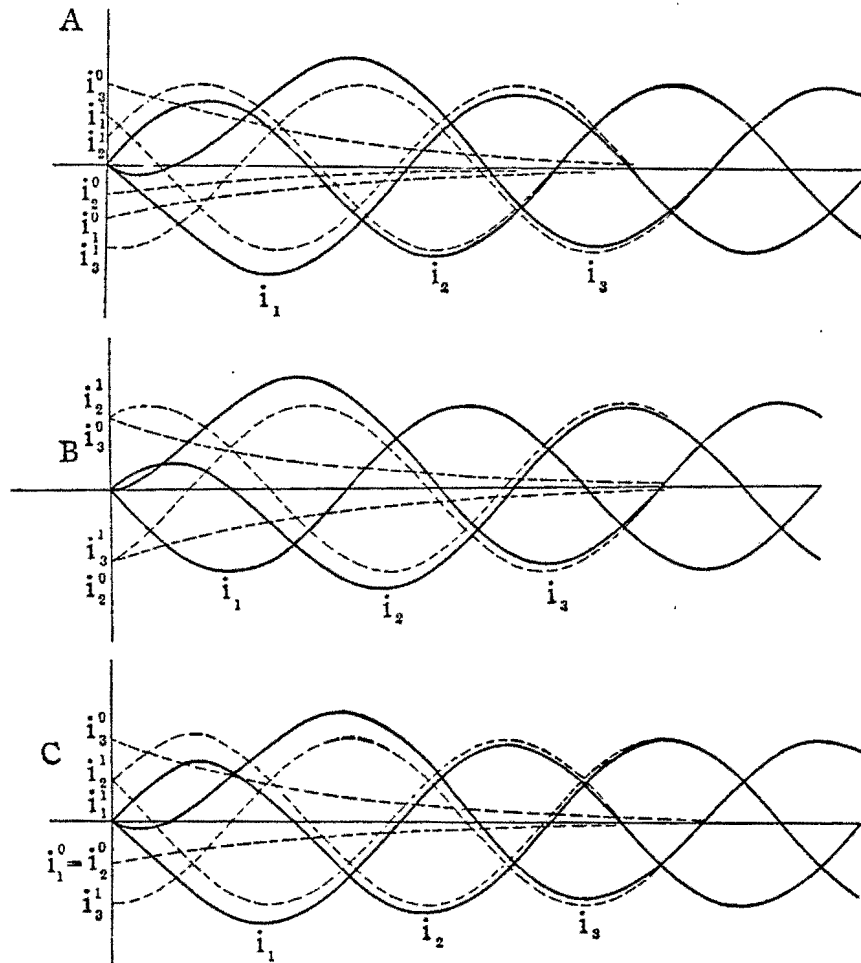

Fig. 17. — Single-energy Starting Transient of Three-phase Circuit.

Since the sum of the three three-phase currents at every moment is zero, the sum of the initial values of the three transient currents also is zero. Since the three transient curves i_1^0 , i_2^0 , i_3^0 are proportional to each other (as exponential curves of the same duration $T = \frac{L}{r}$), and the sum of their initial values is zero, it follows

shown dotted in Fig. 11C. The area of this new voltage curve would be e_0T , and since it is the same as that of the curve e , as seen above, it follows that the area of the voltage curve e is

$$\left. \begin{aligned} \Sigma et &= e_0T, \\ &= ri_0T, \end{aligned} \right\} \quad (3)$$

and, combining (2) and (3), i_0 cancels, and we get the value of T :

$$T = \frac{L}{r}. \quad (4)$$

That is, the initial decrease of current, and therefore of magnetic flux and of induced voltage, is such that if the decrease continued at the same rate, the current, flux, and voltage would become zero after the time $T = \frac{L}{r}$.

The total induced voltage, that is, voltage times time, and therefore also the total current and magnetic flux during the transient, are such that, when maintained at their initial value, they would last for the time $T = \frac{L}{r}$.

Since the curves of current and voltage theoretically never become zero, to get an estimate of the duration of the transient we may determine the time in which the transient decreases to half, or to one-tenth, etc., of its initial value. It is preferable, however, to estimate the duration of the transient by the time T , which it would last if maintained at its initial value. That is, the duration of a transient is considered as the time $T = \frac{L}{r}$.

This time T has frequently been called the "time constant" of the circuit.

The higher the inductance L , the longer the transient lasts, obviously, since the stored energy which the transient dissipates is proportional to L .

The higher the resistance r , the shorter is the duration of the transient, since in the higher resistance the stored energy is more rapidly dissipated.

Using the time constant $T = \frac{L}{r}$ as unit of length for the abscissa, and the initial value as unit of the ordinates, all exponential transients have the same shape, and can thereby be constructed

apparatus, however, these momentary starting currents usually are far more limited than in transformers, by the higher stray field (self-inductive reactance), etc., of the apparatus, resulting from the air gap in the magnetic circuit.

19. As instance of the use of the single-energy transient in engineering calculations may be considered the investigation of the momentary short-circuit phenomena of synchronous alternators. In alternators, especially high-speed high-power machines as turboalternators, the momentary short-circuit current may be many times greater than the final or permanent short-circuit current, and this excess current usually decreases fairly slowly, lasting for many cycles. At the same time, a big current rush occurs in the field. This excess field current shows curious pulsations, of single and of double frequency, and in the beginning the armature currents also show unsymmetrical shapes. Some oscillograms of three-phase, quarter-phase, and single-phase short circuits of turboalternators are shown in Figs. 25 to 28.

By considering the transients of energy storage, these rather complex-appearing phenomena can be easily understood, and predetermined from the constants of the machine with reasonable exactness.

In an alternator, the voltage under load is affected by armature reaction and armature self-induction. Under permanent condition, both usually act in the same way, reducing the voltage at noninductive and still much more at inductive load, and increasing it at antiinductive load; and both are usually combined in one quantity, the synchronous reactance x_0 . In the transients resulting from circuit changes, as short circuits, the self-inductive armature reactance and the magnetic armature reaction act very differently:* the former is instantaneous in its effect, while the latter requires time. The self-inductive armature reactance x_1 consumes a voltage $x_1 i$ by the magnetic flux surrounding the armature conductors, which results from the m.m.f. of the armature current, and therefore requires a component of the magnetic-field flux for its production. As the armature magnetic flux and the current which produces it must be simultaneous (the former being an integral part of the phenomenon of current flow, as seen in Lecture II), it thus follows that the armature reactance appears together

* So also in their effect on synchronous operation, in hunting, etc.

$$\left. \begin{aligned} \Phi &= \Phi_0 e^{-ct} = \Phi_0 e^{-\frac{t}{T}} = \Phi_0 e^{-\frac{rt}{L}}, \\ i &= i_0 e^{-ct} = i_0 e^{-\frac{t}{T}} = i_0 e^{-\frac{rt}{L}}, \\ e &= e_0 e^{-ct} = e_0 e^{-\frac{t}{T}} = e_0 e^{-\frac{rt}{L}}. \end{aligned} \right\} \quad (6)$$

The same equations may be derived directly by the integration of the differential equation:

$$L \frac{di}{dt} + ri = 0, \quad (7)$$

where $L \frac{di}{dt}$ is the inductance voltage, ri the resistance voltage, and their sum equals zero, as the coil is short-circuited.

Equation (7) transposed gives

$$\frac{di}{i} = -\frac{r}{L} dt,$$

hence

$$\log i = -\frac{r}{L} t + \log C,$$

$$i = C e^{-\frac{r}{L} t},$$

and, as for $t = 0$: $i = i_0$, it is: $C = i_0$; hence

$$i = i_0 e^{-\frac{r}{L} t}.$$

14. Usually single-energy transients last an appreciable time, and thereby become of engineering importance, only in highly inductive circuits, as motor fields, magnets, etc.

To get an idea on the duration of such magnetic transients, consider a motor field:

A 4-polar motor has 8 ml. (megalines) of magnetic flux per pole, produced by 6000 ampere turns m.m.f. per pole, and dissipates normally 500 watts in the field excitation.

That is, if i_0 = field-exciting current, n = number of field turns per pole, r = resistance, and L = inductance of the field-exciting circuit, it is

$$i_0^2 r = 500,$$

hence

$$r = \frac{500}{i_0^2}.$$

Thus it is:

$$\frac{\text{momentary short-circuit current}}{\text{permanent short-circuit current}} = \frac{\text{open-circuit field flux}^*}{\text{short-circuit field flux}} =$$

$$\frac{\text{armature reaction plus self-induction}}{\text{self-induction}} = \frac{\text{synchronous reactance}}{\text{self-inductivereactance}} = \frac{x_0}{x_1}.$$

20. Let Φ_1 = field flux of a three-phase alternator (or, in general, polyphase alternator) at open circuit, and this alternator be short-circuited at the time $t = 0$. The field flux then gradually dies down, by the dissipation of its energy in the field circuit, to the short-circuit field flux Φ_0 , as indicated by the curve Φ in Fig. 21A. If m = ratio

$$\frac{\text{armature reaction plus self-induction}}{\text{armature self-induction}} = \frac{x_0}{x_1},$$

it is $\Phi_1 = m\Phi_0$, and the initial value of the field flux consists of the permanent part Φ_0 , and the transient part $\Phi' = \Phi_1 - \Phi_0 = (m-1)\Phi_0$. This is a rather slow transient, frequently of a duration of a second or more.

The armature currents i_1, i_2, i_3 are proportional to the field flux Φ which produces them, and thus gradually decrease, from initial values, which are as many times higher than the final values as Φ_1 is higher than Φ_0 , or m times, and are represented in Fig. 21B.

The resultant m.m.f. of the armature currents, or the armature reaction, is proportional to the currents, and thus follows the same field transient, as shown by F in Fig. 21C.

The field-exciting current is i_0 at open circuit as well as in the permanent condition of short circuit. In the permanent condition of short circuit, the field current i_0 combines with the armature reaction F_0 , which is demagnetizing, to a resultant m.m.f., which produces the short-circuit flux Φ_0 . During the transition period the field flux Φ is higher than Φ_0 , and the resultant m.m.f. must therefore be higher in the same proportion. Since it is the difference between the field current and the armature reaction F , and the latter is proportional to Φ , the field current thus must also be

* If the machine were open-circuited before the short circuit, otherwise the field flux existing before the short circuit. It herefrom follows that the momentary short-circuit current essentially depends on the field flux, and thereby the voltage of the machine, before the short circuit, but is practically independent of the load on the machine before the short circuit and the field excitation corresponding to this load.

The transients of magnetic flux, current, and voltage are shown as *A*, *B*, and *C* in Fig. 13.

The magnetic flux and therewith the current decrease from the initial values Φ_0 and i_0 at the moment t_0 of opening the switch *S*, on curves which must be steeper than those in Fig. 11, since the current passes through a greater resistance, $r + r'$, and thereby dissipates the stored magnetic energy at a greater rate.

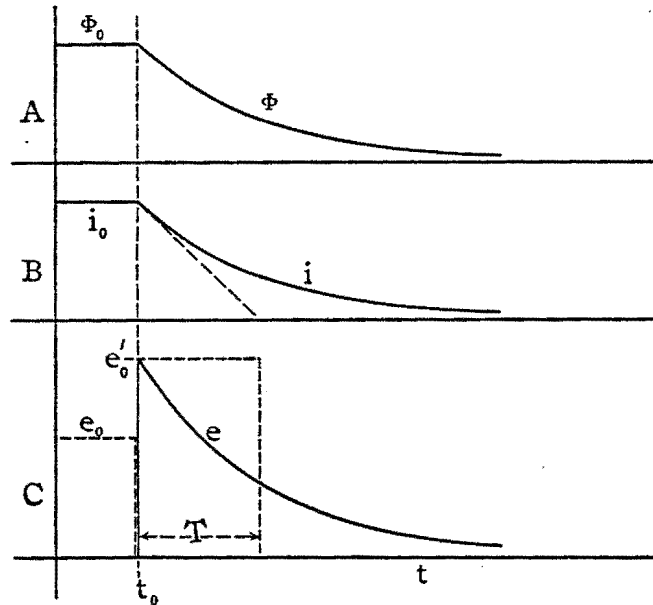

Fig. 13. — Characteristics of Magnetic Single-energy Transient.

The impressed voltage e_0 is withdrawn at the moment t_0 , and a voltage thus induced from this moment onward, of such value as to produce the current i through the resistance $r + r'$. In the first moment, t_0 , the current is still i_0 , and the induced voltage thus must be

$$e_0' = i_0 (r + r'),$$

while the impressed voltage, before t_0 , was

$$e_0 = i_0 r;$$

hence the induced voltage e_0' is greater than the impressed voltage e_0 , in the same ratio as the resistance of the discharge circuit $r + r'$ is greater than the resistance of the coil r through which the impressed voltage sends the current

$$\frac{e_0'}{e_0} = \frac{r + r'}{r}.$$

in Fig. 21C by F . During the initial part of the short circuit, however, while the armature transient is appreciable and the armature currents thus unsymmetrical, as seen in Fig. 22B, their resultant polyphase m.m.f. also shows a transient, the transient of the rotating magnetic field discussed in paragraph 18. That is, it approaches the curve F of Fig. 21C by a series of oscillations, as indicated in Fig. 21E.

Since the resultant m.m.f. of the machine, which produces the flux, is the difference of the field excitation, Fig. 21D and the armature reaction, then if the armature reaction shows an initial oscillation, in Fig. 21E, the field-exciting current must give the same oscillation, since its m.m.f. minus the armature reaction gives the resultant field excitation corresponding to flux Φ . The starting transient of the polyphase armature reaction thus appears in the field current, as shown in Fig. 22C, as an oscillation of full machine frequency. As the mutual induction between armature and field circuit is not perfect, the transient pulsation of armature reaction appears with reduced amplitude in the field current, and this reduction is the greater, the poorer the mutual inductance, that is, the more distant the field winding is from the armature winding. In Fig. 22C a damping of 20 per cent is assumed, which corresponds to fairly good mutual inductance between field and armature, as met in turboalternators.

If the field-exciting circuit contains inductance outside of the alternator field, as is always the case to a slight extent, the pulsations of the field current, Fig. 22C, are slightly reduced and delayed in phase; and with considerable inductance intentionally inserted into the field circuit, the effect of this inductance would require consideration.

From the constants of the alternator, the momentary short-circuit characteristics can now be constructed.

Assuming that the duration of the field transient is

$$T_0 = \frac{L_0}{(m-1)r_0} = 1 \text{ sec.},$$

the duration of the armature transient is

$$T = \frac{L}{r} = .1 \text{ sec.}$$

And assuming that the armature reaction is 5 times the armature

The same reasoning also applies to the transient resulting from several forms of energy storage (provided that the law of proportionality of i , e , Φ , etc., applies), and makes it possible, in investigating the phenomena during the transition period of energy readjustment, to separate the permanent and the transient term, and discuss them separately.

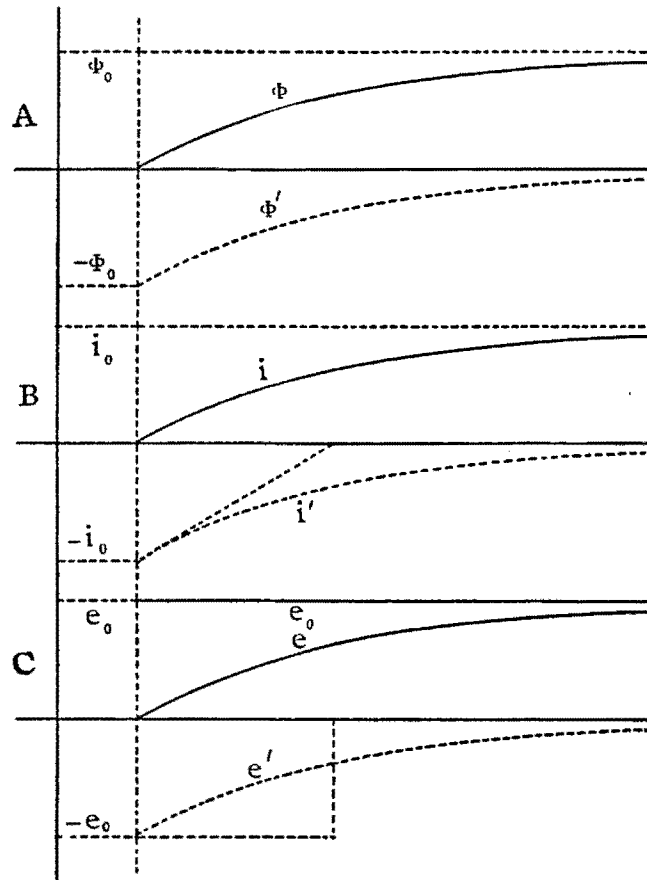

Fig. 14. — Single-energy Starting Transient of Magnetic Circuit.

For instance, in the coil shown in Fig. 10, let the short circuit A be opened, that is, the voltage e_0 be impressed upon the coil. At the moment of time, t_0 , when this is done, current i , magnetic flux Φ , and voltage e on the coil are zero. In final condition, after the transient has passed, the values i_0 , Φ_0 , e_0 are reached. We may then, as discussed above, separate the transient from the permanent term, and consider that at the time t_0 the coil has a permanent current i_0 , permanent flux Φ_0 , permanent voltage e_0 , and in addi-

on the point of the wave at which the phenomenon begins, but not so in their resultant effect.

21. The conditions with a single-phase short circuit are different, since the single-phase armature reaction is pulsating, varying between zero and double its average value, with double the machine frequency.

The slow field transient and its effects are the same as shown in Fig. 21, A to D.

However, the pulsating armature reaction produces a corresponding pulsation in the field circuit. This pulsation is of double

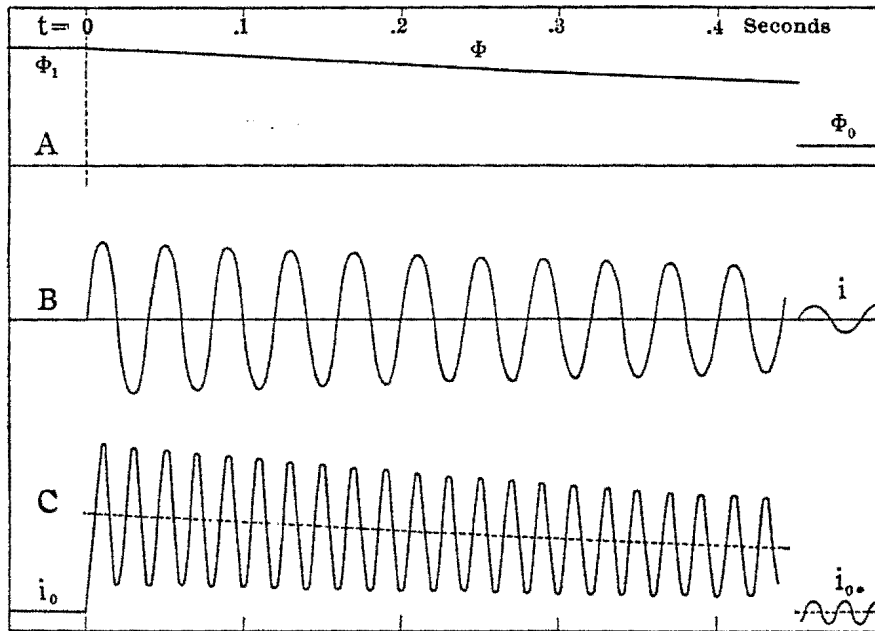

Fig. 23. — Symmetrical Momentary Single-phase Short Circuit of Alternator.

frequency, and is not transient, but equally exists in the final short-circuit current.

Furthermore, the armature transient is not constant in its reaction on the field, but varies with the point of the wave at which the short circuit starts.

Assume that the short circuit starts at that point of the wave where the permanent (or rather slowly transient) armature current should be zero: then no armature transient exists, and the armature current is symmetrical from the beginning, and shows the slow transient of the field, as shown in Fig. 23, where A

LECTURE IV.

SINGLE-ENERGY TRANSIENTS IN ALTERNATING-CURRENT CIRCUITS.

17. Whenever the conditions of an electric circuit are changed in such a manner as to require a change of stored energy, a transition period appears, during which the stored energy adjusts itself from the condition existing before the change to the condition after the change. The currents in the circuit during the transition period can be considered as consisting of the superposition of the permanent current, corresponding to the conditions after the change, and a transient current, which connects the current value before the change with that brought about by the change. That is, if i_1 = current existing in the circuit immediately before, and thus at the moment of the change of circuit condition, and i_2 = current which should exist at the moment of change in accordance with the circuit condition after the change, then the actual current i_1 can be considered as consisting of a part or component i_2 , and a component $i_1 - i_2 = i_0$. The former, i_2 , is permanent, as resulting from the established circuit condition. The current component i_0 , however, is not produced by any power supply, but is a remnant of the previous circuit condition, that is, a transient, and therefore gradually decreases in the manner as discussed in paragraph 13, that is, with a duration $T = \frac{L}{r} = GL$

The permanent current i_2 may be continuous, or alternating, or may be a changing current, as a transient of long duration, etc.

The same reasoning applies to the voltage, magnetic flux, etc.

Thus, let, in an alternating-current circuit traversed by current i_1 , in Fig. 15A, the conditions be changed, at the moment $t = 0$, so as to produce the current i_2 . The instantaneous value of the current i_1 at the moment $t = 0$ can be considered as consisting of the instantaneous value of the permanent current i_2 , shown dotted, and the transient $i_0 = i_1 - i_2$. The latter gradually dies down, with the duration $T = \frac{L}{r}$, on the usual exponential tran-

frequency, and as the result an increase of voltage and a distortion of the quadrature phase occurs, as shown in the oscillogram Fig. 25.

Various momentary short-circuit phenomena are illustrated by the oscillograms Figs. 26 to 28.

Figs. 26*A* and 26*B* show the momentary three-phase short circuit of a 4-polar 25-cycle 1500-kw. steam turbine alternator. The

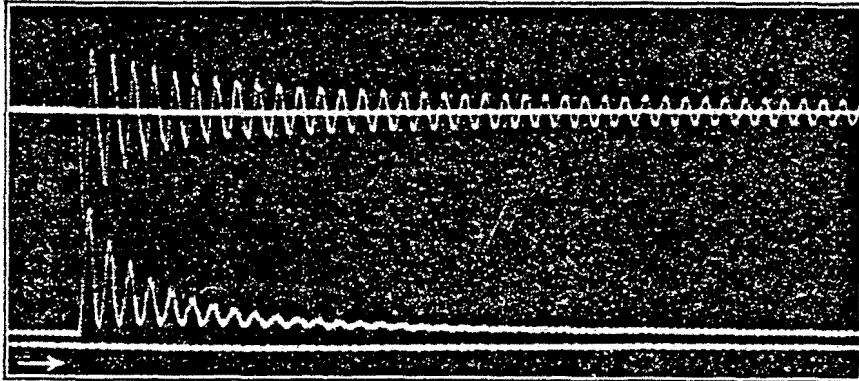

Fig. 26*A*. — cb9399. — Symmetrical.

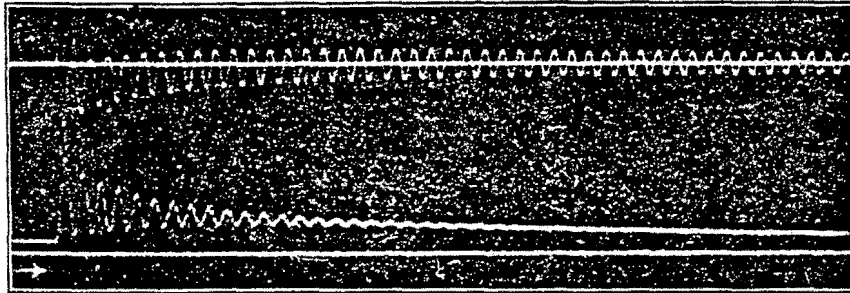

Fig. 26*B*. — cb9397. — Asymmetrical.

Momentary Three-phase Short Circuit of 1500-Kw. 2300-Volt Three-phase Alternator (ATB-4-1500-1800). Oscillograms of Armature Current and Field Current.

lower curve gives the transient of the field-exciting current, the upper curve that of one of the armature currents, — in Fig. 26*A* that current which should be near zero, in Fig. 26*B* that which should be near its maximum value at the moment where the short circuit starts.

Fig. 27 shows the single-phase short circuit of a pair of machines in which the short circuit occurred at the moment in which the armature short-circuit current should be zero; the armature cur-

If the current i_1 is zero, we get the starting of the alternating current in an inductive circuit, as shown in Figs. 16, A, B, C. The starting transient is zero, if the circuit is closed at the moment when the permanent current would be zero (Fig. 16B), and is a maximum when closing the circuit at the maximum point of the permanent-current wave (Fig. 16C). The permanent current and the transient components are shown dotted in Fig. 16, and the resultant or actual current in drawn lines.

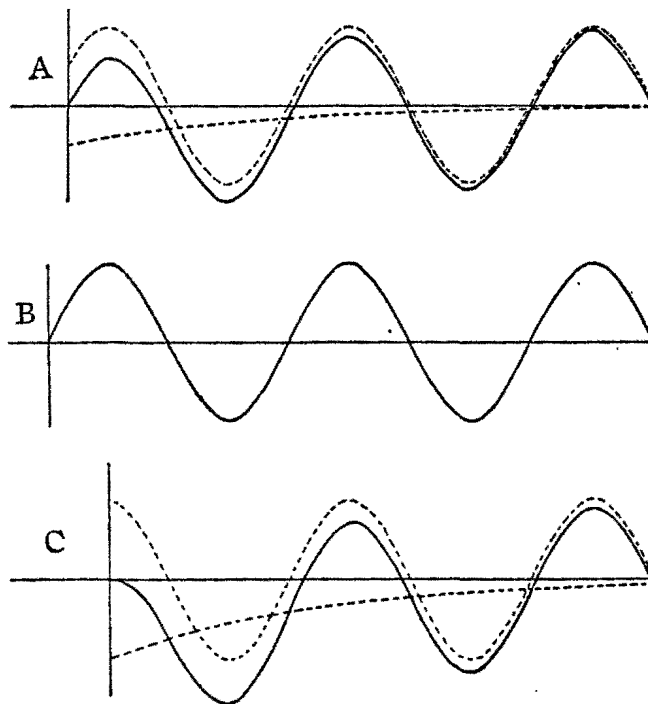

Fig. 16. — Single-energy Starting Transient of Alternating-current Circuit.

18. Applying the preceding to the starting of a balanced three-phase system, we see, in Fig. 17A, that in general the three transients i_1^0 , i_2^0 , and i_3^0 of the three three-phase currents i_1 , i_2 , i_3 are different, and thus also the shape of the three resultant currents during the transition period. Starting at the moment of zero current of one phase, i_1 , Fig. 17B, there is no transient for this current, while the transients of the other two currents, i_2 and i_3 , are equal and opposite, and near their maximum value. Starting, in Fig. 17C, at the maximum value of one current i_3 , we have the maximum value of transient for this current i_3^0 , while the transients of the two other currents, i_1 and i_2 , are equal, have

symmetrical, and the double-frequency pulsation of the field current shows during the first few cycles the alternate high and low peaks resulting from the full-frequency transient pulsation of the rotating magnetic field of armature reaction. The irregular initial decrease of the armature current and the sudden change of its wave shape are due to the transient of the current transformer, through which the armature current was recorded.

Fig. 25 shows a single-phase short circuit of a quarter-phase alternator; the upper wave is the voltage of the phase which is not short-circuited, and shows the increase and distortion resulting from the double-frequency pulsation of the armature reaction.

While the synchronous reactance x_0 can be predetermined with fair accuracy, the self-inductive x_1 is not such a definite quantity. It includes a transient component. The armature magnetic circuit is in mutual inductive relation with the field-exciting circuit. At constant alternating current in the armature, the resultant of the armature m.m.f.'s. and e.m.f.'s. is constant with regard to the field, and the mutual inductance thus does not come into play. During a transient, however, the armature conditions change, and the self-inductance of the exciting circuit is partly transformed into the armature circuit by the ratio of field turns to armature turns, giving rise to a transient effective component of armature self-induction, which depends on the relative rate of change of the armature and the field, and thereby is a maximum in the beginning, and gradually decreases to zero in stationary conditions. This tends to lower the maximum values of the field transients and to increase the duration of the armature transients. This effect is materially affected by the amount of resistance and reactance in the exciting circuit outside of the field winding.

There also exists a mutual inductance between the armature circuits of the three-phase machine, which results in an energy transfer between the phases, during the armature transient.

The instantaneous power of the momentary short-circuit current, and with it the forces acting on driving shaft and prime mover, are proportional to the short-circuit current, being short-circuit current times magnetic field flux. The forces exerted between the armature conductors — which tend to tear and strip the end windings, etc. — are proportional to the square of the short-circuit current.

that the sum of their instantaneous values must be zero at any moment, and therefore the sum of the instantaneous values of the resultant currents (shown in drawn line) must be zero at any moment, not only during the permanent condition, but also during the transition period existing before the permanent condition is reached.

It is interesting to apply this to the resultant magnetic field produced by three equal three-phase magnetizing coils placed under equal angles, that is, to the starting of the three-phase rotating magnetic field, or in general any polyphase rotating magnetic field.

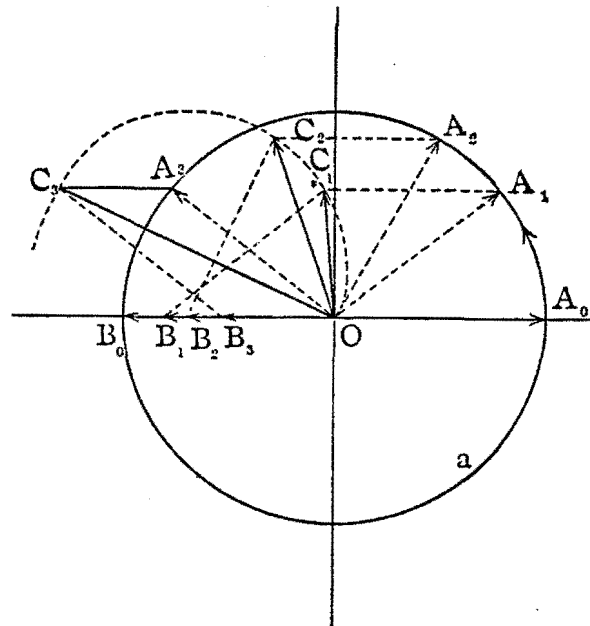

Fig. 18. — Construction of Starting Transient of Rotating Field.

As is well known, three equal magnetizing coils, placed under equal angles and excited by three-phase currents, produce a resultant magnetic field which is constant in intensity, but revolves synchronously in space, and thus can be represented by a concentric circle *a*, Fig. 18.

This, however, applies only to the permanent condition. In the moment of start, all the three currents are zero, and their resultant magnetic field thus also zero, as shown above. Since the magnetic field represents stored energy and thus cannot be produced instantly, a transient must appear in the building up of the rotating field. This can be studied by considering separately

approximate step-by-step method, as illustrated for the starting transient of an alternating-current transformer in "Transient Electric Phenomena and Oscillations," Section I, Chapter XII. Such methods are very cumbersome and applicable only to numerical instances.

An approximate calculation, giving an idea of the shape of the transient of the ironclad magnetic circuit, can be made by neglecting the difference between the rising and decreasing magnetic characteristic, and using the approximation of the magnetic characteristic given by Fröhlich's formula:

$$\mathfrak{B} = \frac{\mathfrak{H}}{\alpha + \sigma\mathfrak{H}}, \quad (1)$$

which is usually represented in the form given by Kennelly:

$$\rho = \frac{\mathfrak{H}}{\mathfrak{B}} = \alpha + \sigma\mathfrak{H}; \quad (2)$$

that is, the reluctivity is a linear function of the field intensity. It gives a fair approximation for higher magnetic densities.

This formula is based on the fairly rational assumption that the permeability of the iron is proportional to its remaining magnetizability. That is, the magnetic-flux density \mathfrak{B} consists of a component \mathfrak{H} , the field intensity, which is the flux density in space, and a component $\mathfrak{B}' = \mathfrak{B} - \mathfrak{H}$, which is the additional flux density carried by the iron. \mathfrak{B}' is frequently called the "metallic-flux density." With increasing \mathfrak{H} , \mathfrak{B}' reaches a finite limiting value, which in iron is about

$$\mathfrak{B}'_{\infty} = 20,000 \text{ lines per cm}^2. *$$

At any density \mathfrak{B}' , the remaining magnetizability then is $\mathfrak{B}'_{\infty} - \mathfrak{B}'$, and, assuming the (metallic) permeability as proportional hereto, gives

$$\mu = c(\mathfrak{B}'_{\infty} - \mathfrak{B}'),$$

and, substituting

$$\mu = \frac{\mathfrak{B}'}{\mathfrak{H}'},$$

gives

$$\mathfrak{B}' = \frac{c\mathfrak{B}'_{\infty}\mathfrak{H}'}{1 + c\mathfrak{H}'},$$

* See "On the Law of Hysteresis," Part II, A.I.E.E. Transactions, 1892, page 621.

From this polar diagram of the rotating field, in Fig. 19, values \overline{OC} can now be taken, corresponding to successive moments of time, and plotted in rectangular coördinates, as done in Fig. 20. As seen, the rotating field builds up from zero at the moment of closing the circuit, and reaches the final value by a series of oscillations; that is, it first reaches beyond the permanent value, then drops below it, rises again beyond it, etc.

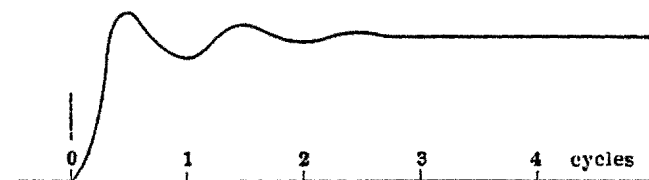

Fig. 20. — Starting Transient of Rotating Field: Rectangular Form.

We have here an oscillatory transient, produced in a system with only one form of stored energy (magnetic energy), by the combination of several simple exponential transients. However, it must be considered that, while energy can be stored in one form only, as magnetic energy, it can be stored in three electric circuits, and a transfer of stored magnetic energy between the three electric circuits, and therewith a surge, thus can occur.

It is interesting to note that the rotating-field transient is independent of the point of the wave at which the circuit is closed. That is, while the individual transients of the three three-phase currents vary in shape with the point of the wave at which they start, as shown in Fig. 17, their polyphase resultant always has the same oscillating approach to a uniform rotating field, of duration $T = \frac{L}{r}$.

The maximum value, which the magnetic field during the transition period can reach, is limited to less than double the final value, as is obvious from the construction of the field, Fig. 19. It is evident herefrom, however, that in apparatus containing rotating fields, as induction motors, polyphase synchronous machines, etc., the resultant field may under transient conditions reach nearly double value, and if then it reaches far above magnetic saturation, excessive momentary currents may appear, similar as in starting transformers of high magnetic density. In polyphase rotary

netic circuit, and $\frac{a}{b}$ the saturation value of the flux in the iron. That is, for $i = 0$, $\frac{n\Phi'}{i} = L_1$; and for $i = \infty$, $\Phi' = \frac{a}{b}$.

If $r =$ resistance, the duration of the component of the transient resulting from the air flux would be

$$T_2 = \frac{L_2}{r} = \frac{nc 10^{-8}}{r}, \quad (5)$$

and the duration of the transient which would result from the initial inductance of the iron flux would be

$$T_1 = \frac{L_1}{r} = \frac{na 10^{-8}}{r}. \quad (6)$$

The differential equation of the transient is: induced voltage plus resistance drop equal zero; that is,

$$n \frac{d\Phi}{dt} 10^{-8} + ri = 0.$$

Substituting (3) and differentiating gives

$$\frac{na 10^{-8}}{(1 + bi)^2} \frac{di}{dt} + nc 10^{-8} \frac{di}{dt} + ri = 0,$$

and, substituting (5) and (6),

$$\left\{ \frac{T_1}{(1 + bi)^2} + T_2 \right\} \frac{di}{dt} + i = 0;$$

hence, separating the variables,

$$\frac{T_1 di}{i(1 + bi)^2} + \frac{T_2 di}{i} + dt = 0. \quad (7)$$

The first term is integrated by resolving into partial fractions:

$$\frac{1}{i(1 + bi)^2} = \frac{1}{i} - \frac{b}{1 + bi} - \frac{b}{(1 + bi)^2},$$

and the integration of differential equation (7) then gives

$$T_1 \log \frac{i}{1 + bi} + T_2 \log i + \frac{T_1}{1 + bi} + t + C = 0. \quad (8)$$

If then, for the time $t = t_0$, the current is $i = i_0$, these values substituted in (8) give the integration constant C :

$$T_1 \log \frac{i_0}{1 + bi_0} + T_2 \log i_0 + \frac{T_1}{1 + bi_0} + t_0 + C = 0, \quad (9)$$

with the armature current, that is, is instantaneous. The armature reaction, however, is the m.m.f. of the armature current in its reaction on the m.m.f. of the field-exciting current. That is, that part $x_2 = x_0 - x_1$ of the synchronous reactance which corresponds to the armature reaction is not a true reactance at all, consumes no voltage, but represents the consumption of field ampere turns by the m.m.f. of the armature current, and the corresponding change of field flux. Since, however, the field flux represents stored magnetic energy, it cannot change instantly, and the armature reaction thus does not appear instantaneously with the armature current, but shows a transient which is determined essentially by the constants of the field circuit, that is, is the counterpart of the field transient of the machine.

If then an alternator is short-circuited, in the first moment only the true self-inductive part x_1 of the synchronous reactance exists, and the armature current thus is $i_1 = \frac{e_0}{x_1}$, where e_0 is the induced e.m.f., that is, the voltage corresponding to the magnetic-field excitation flux existing before the short circuit. Gradually the armature reaction lowers the field flux, in the manner as represented by the synchronous reactance x_0 , and the short-circuit current decreases to the value $i_0 = \frac{e_0}{x_0}$.

The ratio of the momentary short-circuit current to the permanent short-circuit current thus is, approximately, the ratio $\frac{i_1}{i_0} = \frac{x_0}{x_1}$, that is, synchronous reactance to self-inductive reactance, or armature reaction plus armature self-induction, to armature self-induction. In machines of relatively low self-induction and high armature reaction, the momentary short-circuit current thus may be many times the permanent short-circuit current.

The field flux remaining at short circuit is that giving the voltage consumed by the armature self-induction, while the decrease of field flux between open circuit and short circuit corresponds to the armature reaction. The ratio of the open-circuit field flux to the short-circuit field flux thus is the ratio of armature reaction plus self-induction, to the self-induction; or of the synchronous reactance to the self-inductive reactance: $\frac{x_0}{x_1}$.

LECTURE VI.

DOUBLE-ENERGY TRANSIENTS.

24. In a circuit in which energy can be stored in one form only, the change in the stored energy which can take place as the result of a change of the circuit conditions is an increase or decrease. The transient can be separated from the permanent condition, and then always is the representation of a gradual decrease of energy. Even if the stored energy after the change of circuit conditions is greater than before, and during the transition period an increase of energy occurs, the representation still is by a decrease of the transient. This transient then is the difference between the energy storage in the permanent condition and the energy storage during the transition period.

If the law of proportionality between current, voltage, magnetic flux, etc., applies, the single-energy transient is a simple exponential function:

$$y = y_0 e^{-\frac{t}{T_0}}, \quad (1)$$

where

$$\begin{aligned} y_0 &= \text{initial value of the transient, and} \\ T_0 &= \text{duration of the transient,} \end{aligned}$$

that is, the time which the transient voltage, current, etc., would last if maintained at its initial value.

The duration T_0 is the ratio of the energy-storage coefficient to the power-dissipation coefficient. Thus, if energy is stored by the current i , as magnetic field,

$$T_0 = \frac{L}{r}, \quad (2)$$

where L = inductance = coefficient of energy storage by the current, r = resistance = coefficient of power dissipation by the current.

If the energy is stored by the voltage e , as dielectric field, the duration of the transient would be

$$T_0' = \frac{C}{g}, \quad (3)$$

proportional to Φ . Thus, as it is $i = i_0$ at Φ_0 , during the transition period it is $i = \frac{\Phi}{\Phi_0} i_0$. Hence, the field-exciting current traverses the same transient, from an initial value i_0' to the normal value i_0 , as the field flux Φ and the armature currents.

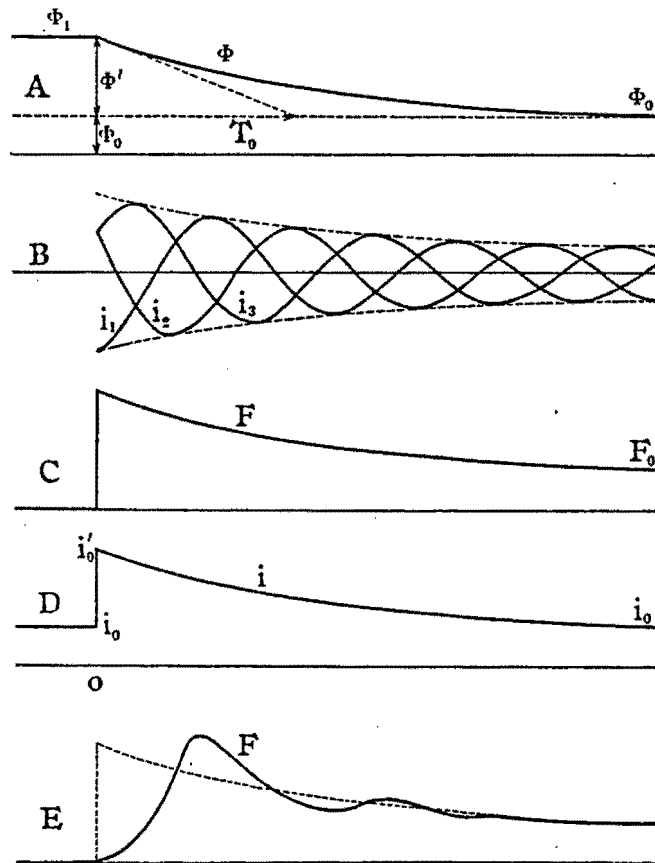

Fig. 21. — Construction of Momentary Short Circuit Characteristic of Poly-phase Alternator.

Thus, at the moment of short circuit a sudden rise of field current must occur, to maintain the field flux at the initial value Φ_1 against the demagnetizing armature reaction. In other words, the field flux Φ decreases at such a rate as to induce in the field circuit the e.m.f. required to raise the field current in the proportion m , from i_0 to i_0' , and maintain it at the values corresponding to the transient i , Fig. 21D.

As seen, the transients Φ ; i_1, i_2, i_3 ; F ; i are proportional to each other, and are a field transient. If the field, excited by current i_0

energy is dissipated before this. This latter case occurs when the dissipation of energy is very rapid, the resistance (or conductance) high, and therefore gives transients, which rarely are of industrial importance, as they are of short duration and of low power. It therefore is sufficient to consider the oscillating double-energy transient, that is, the case in which the energy changes periodically between its two forms, during its gradual dissipation.

This may be done by considering separately the periodic transfer, or pulsation of the energy between its two forms, and the gradual dissipation of energy.

A. *Pulsation of energy.*

25. The magnetic energy is a maximum at the moment when the dielectric energy is zero, and when all the energy, therefore, is magnetic; and the magnetic energy is then

$$\frac{Li_0^2}{2},$$

where i_0 = maximum value of transient current.

The dielectric energy is a maximum at the moment when the magnetic energy is zero, and all the energy therefore dielectric, and is then

$$\frac{Ce_0^2}{2},$$

where e_0 = maximum value of transient voltage.

As it is the same stored energy which alternately appears as magnetic and as dielectric energy, it obviously is

$$\frac{Li_0^2}{2} = \frac{Ce_0^2}{2}. \quad (8)$$

This gives a relation between the maximum value of transient current and the maximum value of transient voltage:

$$\frac{e_0}{i_0} = \sqrt{\frac{L}{C}}. \quad (9)$$

$\sqrt{\frac{L}{C}}$ therefore is of the nature of an impedance z_0 , and is called the *natural impedance*, or the *surge impedance*, of the circuit; and its reciprocal, $\sqrt{\frac{C}{L}} = y_0$, is the *natural admittance*, or the *surge admittance*, of the circuit.

start with the values $-i_1'$, $-i_2'$, $-i_3'$. The resultant armature currents are derived by the addition of these armature transients upon the permanent armature currents, in the manner as discussed in paragraph 18, except that in the present case even the permanent armature currents i_1 , i_2 , i_3 are slow transients.

In Fig. 22B are shown the three armature short-circuit currents, in their actual shape as resultant from the armature transient and the field transient. The field transient (or rather its beginning) is shown as Fig. 22A. Fig. 22B gives the three armature

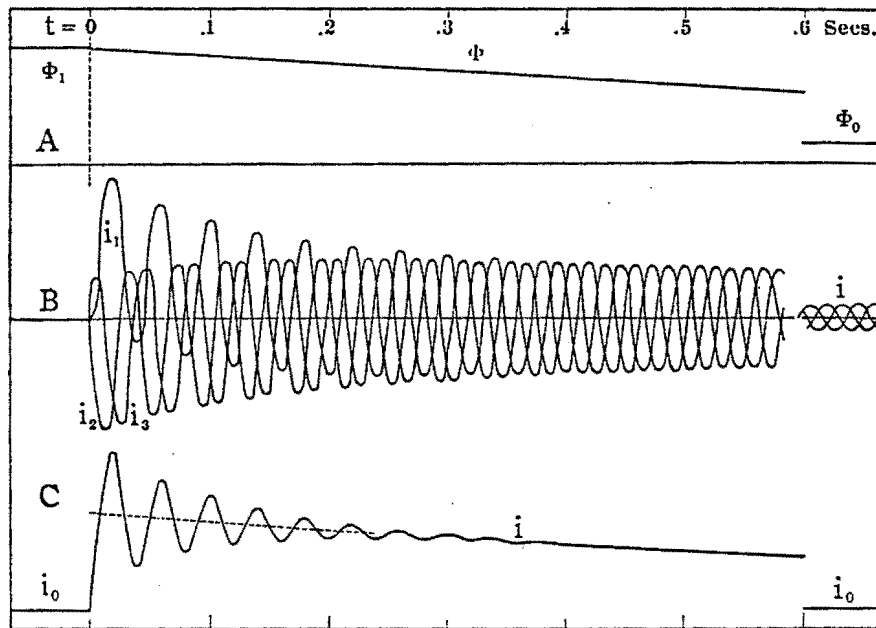

Fig. 22. — Momentary Short Circuit Characteristic of Three-phase Alternator.

currents for the case where the circuit is closed at the moment when i_1 should be maximum; i_1 then shows the maximum transient, and i_2 and i_3 transients in opposite direction, of half amplitude. These armature transients rapidly disappear, and the three currents become symmetrical, and gradually decrease with the field transient to the final value indicated in the figure.

The resultant m.m.f. of three three-phase currents, or the armature reaction, is constant if the currents are constant, and as the currents decrease with the field transient, the resultant armature reaction decreases in the same proportion as the field, as is shown

oscillating voltages, that is, acts as a short circuit for the transformer oscillation, and therefore protects the latter. Inversely, if the large oscillating current of a cable enters a reactive device, as a current transformer, it produces enormous voltages therein. Thus, cable oscillations are more liable to be destructive to the reactive apparatus, transformers, etc., connected with the cable, than to the cable itself.

A transmission line is intermediate in the values of z_0 and y_0 between the cable and the reactive apparatus, thus acting like a reactive apparatus to the former, like a cable toward the latter. Thus, the transformer is protected by the transmission line in oscillations originating in the transformer, but endangered by the transmission line in oscillations originating in the transmission line.

The simple consideration of the relative values of $z_0 = \sqrt{\frac{L}{C}}$ in the different parts of an electric system thus gives considerable information on the relative danger and protective action of the parts on each other, and shows the reason why some elements, as current transformers, are far more liable to destruction than others; but also shows that disruptive effects of transient voltages, observed in one apparatus, may not and very frequently do not originate in the damaged apparatus, but originate in another part of the system, in which they were relatively harmless, and become dangerous only when entering the former apparatus.

26. If there is a periodic transfer between magnetic and dielectric energy, the transient current i and the transient voltage e successively increase, decrease, and become zero.

The current thus may be represented by

$$i = i_0 \cos (\phi - \gamma), \quad (12)$$

where i_0 is the maximum value of current, discussed above, and

$$\phi = 2 \pi ft, \quad (13)$$

where f = the frequency of this transfer (which is still undetermined), and γ the phase angle at the starting moment of the transient; that is,

$$i_1 = i_0 \cos \gamma = \text{initial transient current.} \quad (14)$$

As the current i is a maximum at the moment when the magnetic energy is a maximum and the dielectric energy zero, the voltage e

self-induction, that is, the synchronous reactance is 6 times the self-inductive reactance, $\frac{x_0}{x_1} = m = 6$. The frequency is 25 cycles.

If Φ_1 is the initial or open-circuit flux of the machine, the short-circuit flux is $\Phi_0 = \frac{\Phi_1}{m} = \frac{1}{6}\Phi_1$, and the field transient Φ is a transient of duration 1 sec., connecting Φ_1 and Φ_0 , Fig. 22A, represented by the expression

$$\Phi = \Phi_0 + (\Phi_1 - \Phi_0)e^{-\frac{t}{T_0}}.$$

The permanent armature currents i_1, i_2, i_3 then are currents starting with the values $m \frac{e_0}{x_0}$, and decreasing to the final short-circuit current $\frac{e_0}{x_0}$, on the field transient of duration T_0 . To these currents are added the armature transients, of duration T , which start with initial values equal but opposite in sign to the initial values of the permanent (or rather slowly transient) armature currents, as discussed in paragraph 18, and thereby give the asymmetrical resultant currents, Fig. 22B.

The field current i gives the same slow transient as the flux Φ , starting with $i_0' = mi_0$, and tapering to the final value i_0 . Upon this is superimposed the initial full-frequency pulsation of the armature reaction. The transient of the rotating field, of duration $T = .1$ sec., is constructed as in paragraph 18, and for its instantaneous values the percentage deviation of the resultant field from its permanent value is calculated. Assuming 20 per cent damping in the reaction on the field excitation, the instantaneous values of the slow field transient (that is, of the current $(i - i_0)$, since i_0 is the permanent component) then are increased or decreased by 80 per cent of the percentage variation of the transient field of armature reaction from uniformity, and thereby the field curve, Fig. 22C, is derived. Here the correction for the external field inductance is to be applied, if considerable.

Since the transient of the armature reaction does not depend on the point of the wave where the short circuit occurs, it follows that the phenomena at the short circuit of a polyphase alternator are always the same, that is, independent of the point of the wave at which the short circuit occurs, with the exception of the initial wave shape of the armature currents, which individually depend

decreases, and as at lower magnetic densities the permeability of the iron is higher, with the decrease of voltage the permeability of the iron and thereby the inductance of the electric circuit interlinked with it increases, and, resulting from this increased magnetic energy storage coefficient L , there follows a slower period of oscillation, that is, a decrease of frequency, as seen on the oscillogram, from 55 cycles to 20 cycles per second.

If the energy transfer is not a simple sine wave, it can be represented by a series of sine waves, and in this case the above equations (12) and (15) would still apply, but the calculation of the frequency f would give a number of values which represent the different component sine waves.

The dielectric field of a condenser, or its "charge," is capacity times voltage: Ce . It is, however, the product of the current flowing into the condenser, and the time during which this current flows into it, that is, it equals it .

Applying the law

$$Ce = it \quad (17)$$

to the oscillating energy transfer: the voltage at the condenser changes during a half-cycle from $-e_0$ to $+e_0$, and the condenser charge thus is

$$2e_0C;$$

the current has a maximum value i_0 , thus an average value $\frac{2}{\pi}i_0$, and as it flows into the condenser during one-half cycle of the frequency f , that is, during the time $\frac{1}{2f}$, it is

$$2e_0C = \frac{2}{\pi}i_0 \frac{1}{2f},$$

which is the expression of the condenser equation (17) applied to the oscillating energy transfer.

Transposed, this equation gives

$$f = \frac{i_0}{2\pi e_0C}, \quad (18)$$

and substituting equation (10) into (18), and canceling with i_0 , gives

$$f = \frac{1}{2\pi\sqrt{LC}} = \frac{1}{2\pi\sigma} \quad (19)$$

is the field transient Φ (the same as in Fig. 22A) and B the armature current, decreasing from an initial value, which is m times the final value, on the field transient.

Assume then that the mutual induction between field and armature is such that 60 per cent of the pulsation of armature reaction appears in the field current. Forty per cent damping for the double-frequency reaction would about correspond to the 20 per cent damping assumed for the transient full-frequency pulsation of the polyphase machine. The transient field current thus pulsates by 60 per cent around the slow field transient, as shown by Fig. 23C; passing a maximum for every maximum of armature

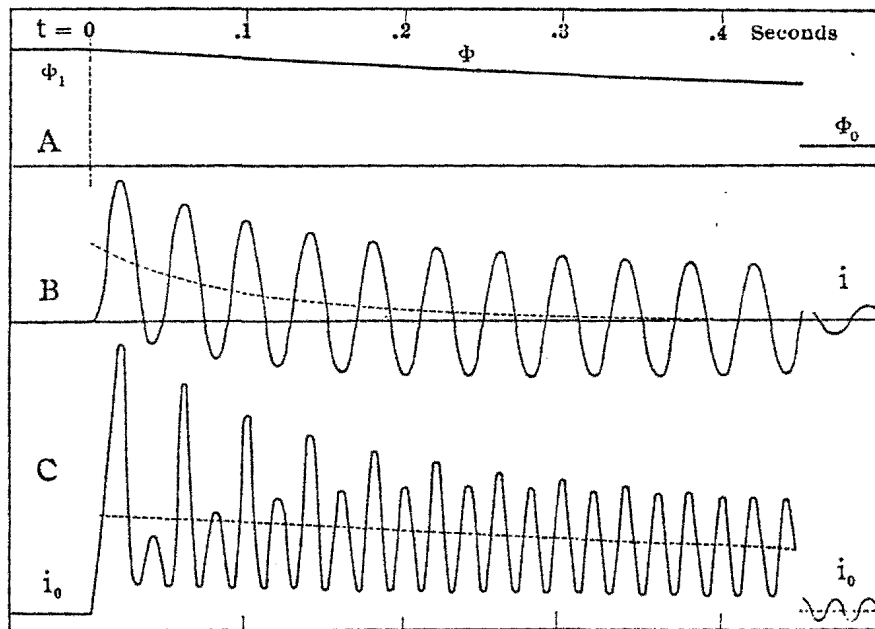

Fig. 24. — Asymmetrical Momentary Single-phase Short Circuit of Alternator.

current, and thus maximum of armature reaction, and a minimum for every zero value of armature current, and thus armature reaction.

Such single-phase short-circuit transients have occasionally been recorded by the oscillograph, as shown in Fig. 27. Usually, however, the circuit is closed at a point of the wave where the permanent armature current would not be zero, and an armature transient appears, with an initial value equal, but opposite to, the initial value of the permanent armature current. This is shown in Fig. 24 for the case of closing the circuit at the moment where the

transient. In the latter case, the duration of the transient would be

$$T_0 = \frac{L}{r},$$

and with only half the energy magnetic, the duration thus is twice as long, or

$$T_1 = 2 T_0 = \frac{2L}{r}, \tag{23}$$

and hereby the factor

$$h = e^{-\frac{t}{T_1}}$$

multiplies with the values of current and voltage (21) and (22).

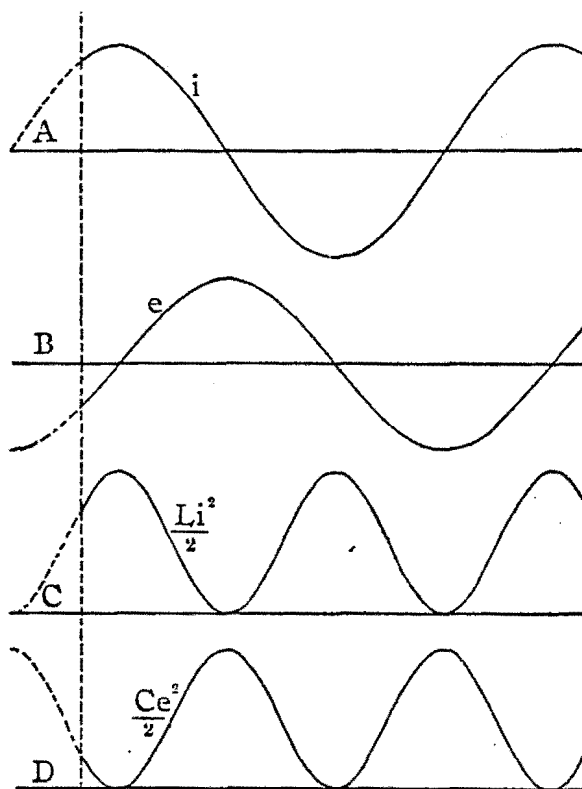

Fig. 32. — Relation of Magnetic and Dielectric Energy of Transient.

The same applies to the dielectric energy. If all the energy were dielectric, it would be dissipated by a transient of the duration:

$$T_0' = \frac{C}{g};$$

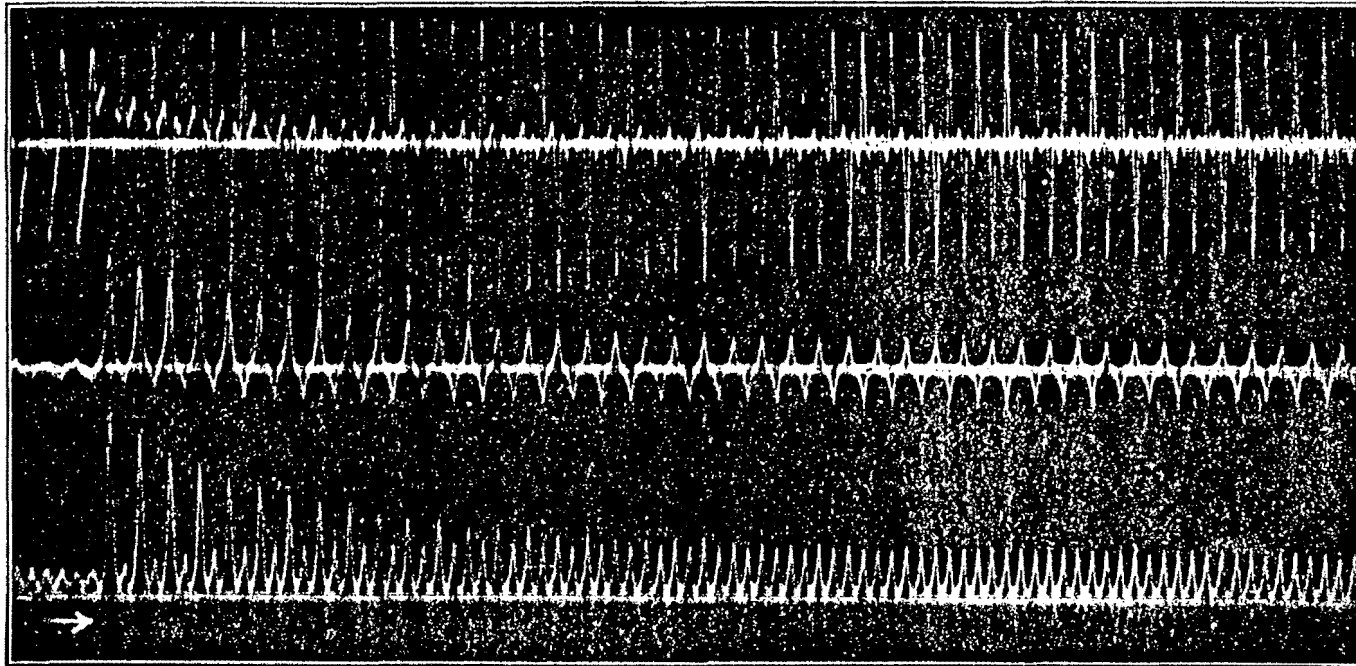

Fig. 25. — cd9762. — Momentary Single-phase Short Circuit of 1875-Kw. 2300-Volt Two-phase Alternator (AQB-4-1875M-1800). Oscillogram of Armature Voltage of Open Phase, Armature Current of Short-circuited Phase, and Field Current.

transformers, etc., and is not the case in telegraph or telephone lines, etc. It is very nearly the case if the capacity is due to electrostatic condensers, but not if the capacity is that of electrolytic condensers, aluminum cells, etc.

Combining now the power-dissipation equation (25) as factor with the equations of periodic energy transfer, (21) and (22), gives the complete equations of the double-energy transient of the circuit containing inductance and capacity:

$$\left. \begin{aligned} i &= \epsilon^{-ut} \left\{ i_1 \cos \frac{t}{\sigma} - y_0 e_1 \sin \frac{t}{\sigma} \right\}, \\ e &= \epsilon^{-ut} \left\{ e_1 \cos \frac{t}{\sigma} + z_0 i_1 \sin \frac{t}{\sigma} \right\}, \end{aligned} \right\}^* \quad (28)$$

where

$$\left. \begin{aligned} z_0 &= \sqrt{\frac{L}{C}} = \frac{1}{y_0}, \\ u &= \frac{1}{2} \left\{ \frac{r}{L} + \frac{g}{C} \right\}, \end{aligned} \right\} \quad (29)$$

$$\sigma = \sqrt{LC}, \quad (30)$$

and i_1 and e_1 are the initial values of the transient current and voltage respectively.

As instance are constructed, in Fig. 33, the transients of current and of voltage of a circuit having the constants:

Inductance,	$L = 1.25 \text{ mh} = 1.25 \times 10^{-3} \text{ henrys};$
Capacity,	$C = 2 \text{ } \mu\text{f} = 2 \times 10^{-6} \text{ farads};$
Resistance,	$r = 2.5 \text{ ohms};$
Conductance,	$g = 0.008 \text{ mho},$

in the case, that

The initial transient current,	$i_1 = 140 \text{ amperes};$
The initial transient voltage,	$e_1 = 2000 \text{ volts}.$

It is, by the preceding equations:

$$\sigma = \sqrt{LC} = 5 \times 10^{-5},$$

$$f = \frac{1}{2\pi\sigma} = 3180 \text{ cycles per second},$$

$$z_0 = \sqrt{\frac{L}{C}} = 25 \text{ ohms},$$

$$y_0 = \sqrt{\frac{C}{L}} = 0.04 \text{ mho},$$

$$\frac{1}{\sigma} = \omega = 2\pi f$$

rent wave, therefore, is symmetrical, and the field current shows only the double-frequency pulsation. Only a few half-waves were recorded before the circuit breaker opened the short circuit.

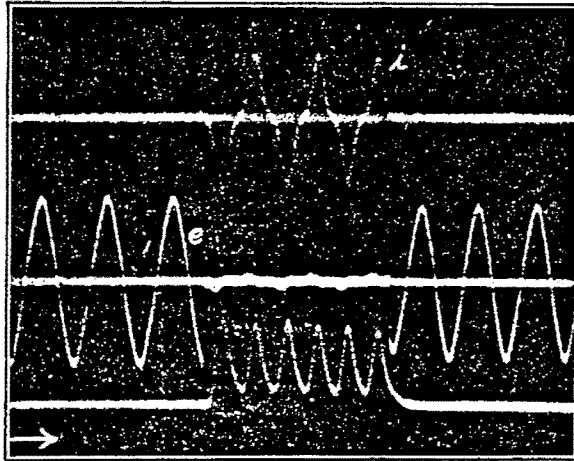

Fig. 27. — cp5128. — Symmetrical. Momentary Single-phase Short Circuit of Alternator. Oscillogram of Armature Current, Armature Voltage, and Field Current. (Circuit breaker opens.)

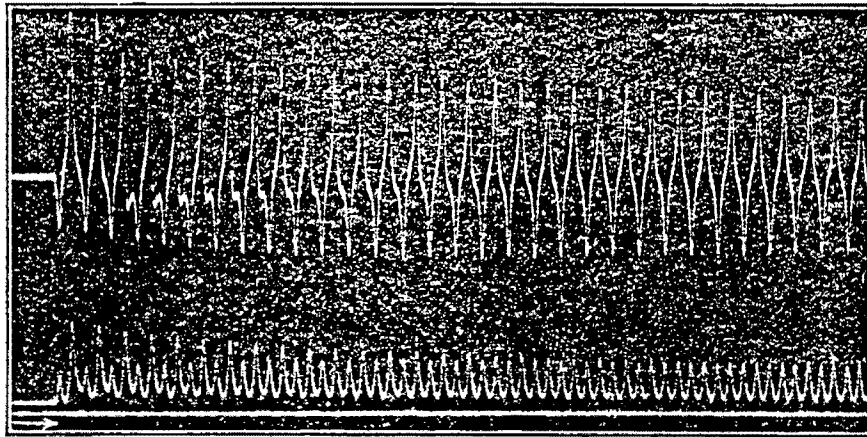

Fig. 28. — cp6565. — Asymmetrical. Momentary Single-phase Short Circuit of 5000-Kw. 11,000-Volt Three-phase Alternator (ATB-6-5000-500). Oscillogram of Armature Current and Field Current.

Fig. 28 shows the single-phase short circuit of a 6-polar 5000-kw. 11,000-volt steam turbine alternator, which occurred at a point of the wave where the armature current should be not far from its maximum. The transient armature current, therefore, starts un-

Fig. 33A gives the periodic components of current and voltage:

$$\begin{aligned}i' &= 140 \cos 0.2 t - 80 \sin 0.2 t, \\e' &= 2000 \cos 0.2 t + 3500 \sin 0.2 t.\end{aligned}$$

Fig. 33B gives

$$\begin{aligned}\text{The magnetic-energy transient, } & h = e^{-t}, \\ \text{The dielectric-energy transient, } & k = e^{-2t}, \\ \text{And the resultant transient, } & hk = e^{-3t}.\end{aligned}$$

And Fig. 33C gives the transient current, $i = hki'$, and the transient voltage, $e = hke'$.

LECTURE V.

SINGLE-ENERGY TRANSIENT OF IRONCLAD CIRCUIT.

22. Usually in electric circuits, current, voltage, the magnetic field and the dielectric field are proportional to each other, and the transient thus is a simple exponential, if resulting from one form of stored energy, as discussed in the preceding lectures. This, however, is no longer the case if the magnetic field contains iron or other magnetic materials, or if the dielectric field reaches densities beyond the dielectric strength of the carrier of the field, etc.; and the proportionality between current or voltage and their respective fields, the magnetic and the dielectric, thus ceases, or, as it may be expressed, the inductance L is not constant, but varies with the current, or the capacity is not constant, but varies with the voltage.

The most important case is that of the ironclad magnetic circuit, as it exists in one of the most important electrical apparatus, the alternating-current transformer. If the iron magnetic circuit contains an air gap of sufficient length, the magnetizing force consumed in the iron, below magnetic saturation, is small compared with that consumed in the air gap, and the magnetic flux, therefore, is proportional to the current up to the values where magnetic saturation begins. Below saturation values of current, the transient thus is the simple exponential discussed before.

If the magnetic circuit is closed entirely by iron, the magnetic flux is not proportional to the current, and the inductance thus not constant, but varies over the entire range of currents, following the permeability curve of the iron. Furthermore, the transient due to a decrease of the stored magnetic energy differs in shape and in value from that due to an increase of magnetic energy, since the rising and decreasing magnetization curves differ, as shown by the hysteresis cycle.

Since no satisfactory mathematical expression has yet been found for the cyclic curve of hysteresis, a mathematical calculation is not feasible, but the transient has to be calculated by an

where

$$u = \frac{1}{2} \left(\frac{r}{L} + \frac{g}{C} \right); \quad (7)$$

hence the total expression of transient current and voltage is

$$\left. \begin{aligned} i &= i_0 e^{-ut} \cos(\phi - \gamma) \\ e &= e_0 e^{-ut} \sin(\phi - \gamma) \end{aligned} \right\} \quad (8)$$

γ , e_0 , and i_0 follow from the initial values e' and i' of the transient, at $t = 0$ or $\phi = 0$:

$$\left. \begin{aligned} i' &= i_0 \cos \gamma \\ e' &= -e_0 \sin \gamma \end{aligned} \right\}; \quad (9)$$

hence

$$\tan \gamma = -\frac{e'}{i'} \frac{i_0}{e_0} = -y_0 \frac{e'}{i'}. \quad (10)$$

The preceding equations of the double-energy transient apply to the circuit in which capacity and inductance are massed, as, for instance, the discharge or charge of a condenser through an inductive circuit.

Obviously, no material difference can exist, whether the capacity and the inductance are separately massed, or whether they are intermixed, a piece of inductance and piece of capacity alternating, or uniformly distributed, as in the transmission line, cable, etc.

Thus, the same equations apply to any point of the transmission line.

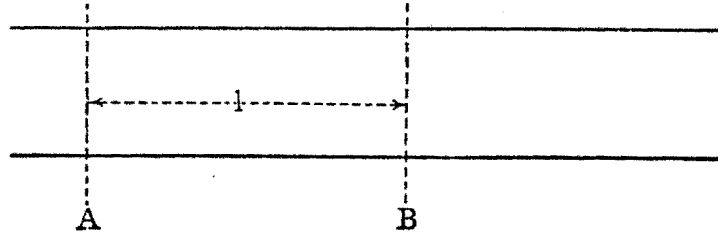

Fig. 34.

However, if (8) are the equations of current and voltage at a point A of a line, shown diagrammatically in Fig. 34, at any other point B , at distance l from the point A , the same equations will apply, but the phase angle γ , and the maximum values e_0 and i_0 , may be different.

Thus it

$$\left. \begin{aligned} i &= c_0 e^{-ut} \cos(\phi - \gamma) \\ e &= z_0 c_0 e^{-ut} \sin(\phi - \gamma) \end{aligned} \right\} \quad (11)$$

or, substituting

$$\frac{1}{c\mathfrak{B}_\infty'} = \alpha, \quad \frac{1}{\mathfrak{B}_\infty'} = \sigma,$$

gives equation (1).

For $\mathfrak{H} = 0$ in equation (1), $\frac{\mathfrak{B}}{\mathfrak{H}} = \frac{1}{\alpha}$; for $\mathfrak{H} = \infty$, $\mathfrak{B} = \frac{1}{\sigma}$; that is, in equation (1), $\frac{1}{\alpha}$ = initial permeability, $\frac{1}{\sigma}$ = saturation value of magnetic density.

If the magnetic circuit contains an air gap, the reluctance of the iron part is given by equation (2), that of the air part is constant, and the total reluctance thus is

$$\rho = \beta + \sigma\mathfrak{H},$$

where $\beta = \alpha$ plus the reluctance of the air gap. Equation (1), therefore, remains applicable, except that the value of α is increased.

In addition to the metallic flux given by equation (1), a greater or smaller part of the flux always passes through the air or through space in general, and then has constant permeance, that is, is given by

$$\mathfrak{B} = c\mathfrak{H}.$$

23. In general, the flux in an ironclad magnetic circuit can, therefore, be represented as function of the current by an expression of the form

$$\Phi = \frac{ai}{1 + bi} + ci, \quad (3)$$

where $\frac{ai}{1 + bi} = \Phi'$ is that part of the flux which passes through the iron and whatever air space may be in series with the iron, and ci is the part of the flux passing through nonmagnetic material.

Denoting now

$$\left. \begin{aligned} L_1 &= na 10^{-8}, \\ L_2 &= nc 10^{-8}, \end{aligned} \right\} \quad (4)$$

where n = number of turns of the electric circuit, which is interlinked with the magnetic circuit, L_2 is the inductance of the air part of the magnetic circuit, L_1 the (virtual) initial inductance, that is, inductance at very small currents, of the iron part of the mag-

Resolving the trigonometric expressions of equation (17) into functions of single angles, we get as equations of current and of voltage products of the transient $e^{-\alpha t}$, and of a combination of the trigonometric expressions:

$$\left. \begin{array}{l} \cos \phi \cos \omega, \\ \sin \phi \cos \omega, \\ \cos \phi \sin \omega, \\ \sin \phi \sin \omega. \end{array} \right\} \quad (19)$$

Line oscillations thus can be expressed in two different forms, either as functions of the sum and difference of time angle ϕ and distance angle ω : ($\phi \pm \omega$), as in (17); or as products of functions of ϕ and functions of ω , as in (19). The latter expression usually is more convenient to introduce the terminal conditions in stationary waves, as oscillations and surges; the former is often more convenient to show the relation to traveling waves.

In Figs. 35 and 36 are shown oscillograms of such line oscillations. Fig. 35 gives the oscillation produced by switching 28 miles of 100-kv. line by high-tension switches onto a 2500-kw. step-up transformer in a substation at the end of a 153-mile three-phase line; Fig. 36 the oscillation of the same system caused by switching on the low-tension side of the step-up transformer.

29. As seen, the phase of current i and voltage e changes progressively along the line l , so that at some distance l_0 current and voltage are 360 degrees displaced from their values at the starting point, that is, are again in the same phase. This distance l_0 is called the wave length, and is the distance which the electric field travels during one period $t_0 = \frac{1}{f}$ of the frequency of oscillation.

As current and voltage vary in phase progressively along the line, the effect of inductance and of capacity, as represented by the inductance voltage and capacity current, varies progressively, and the resultant effect of inductance and capacity, that is, the effective inductance and the effective capacity of the circuit, thus are not the sum of the inductances and capacities of all the line elements, but the resultant of the inductances and capacities of all the line elements combined in all phases. That is, the effective inductance and capacity are derived by multiplying the total inductance and total capacity by $\text{avg}/\cos/$, that is, by $\frac{2}{\pi}$.

and, subtracting (8) from (9), gives

$$t - t_0 = T_1 \log \frac{i_0(1 + bi)}{i(1 + bi_0)} + T_2 \log \frac{i_0}{i} + T_1 \left\{ \frac{1}{1 + bi_0} - \frac{1}{1 + bi} \right\}. \quad (10)$$

This equation is so complex in i that it is not possible to calculate from the different values of t the corresponding values of i ; but inversely, for different values of i the corresponding values of t can be calculated, and the corresponding values of i and t , derived in this manner, can be plotted as a curve, which gives the single-energy transient of the ironclad magnetic circuit.

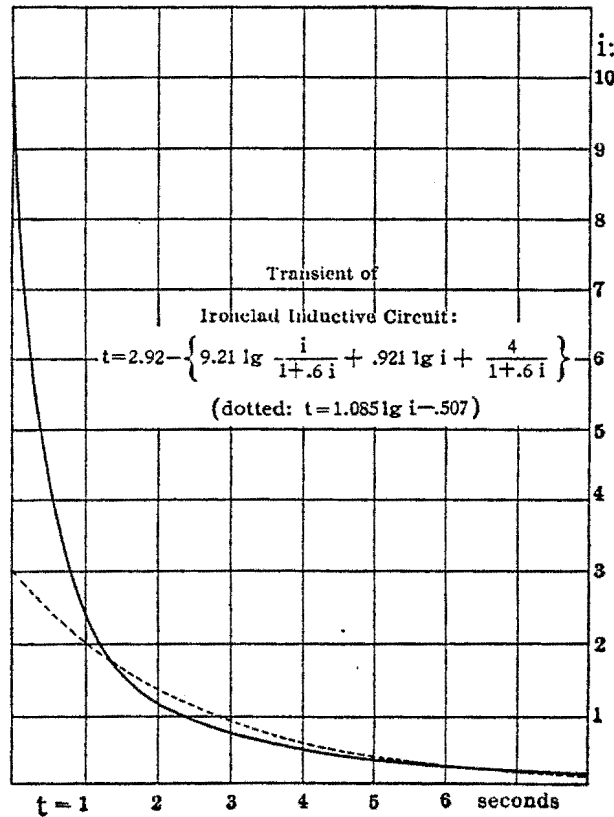

Fig. 29.

Such is done in Fig. 29, for the values of the constants:

$$\begin{aligned} r &= .3, \\ a &= 4 \times 10^5, \\ c &= 4 \times 10^4, \\ b &= .6, \\ n &= 300. \end{aligned}$$

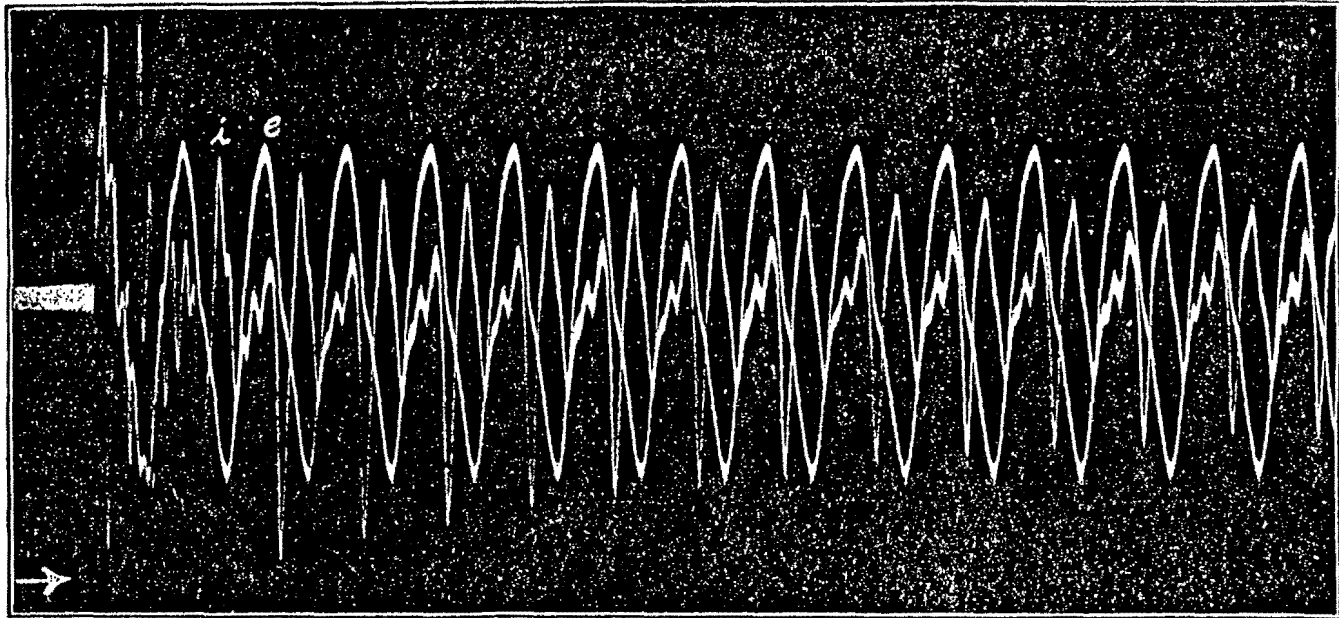

Fig. 36. — cp10002. — Oscillogram of Starting Oscillation of 28 Miles of 100,000-volt Transmission Line: Low-tension Switching.

This gives

$$\begin{aligned} T_1 &= 4, \\ T_2 &= .4. \end{aligned}$$

Assuming $i_0 = 10$ amperes for $t_0 = 0$, gives from (10) the equation:

$$T = 2.92 - \left\{ 9.21 \log^{10} \frac{i}{1 + .6i} + .921 \log^{10} i + \frac{4}{1 + .6i} \right\}.$$

Herein, the logarithms have been reduced to the base 10 by division with $\log^{10} e = .4343$.

For comparison is shown, in dotted line, in Fig. 29, the transient of a circuit containing no iron, and of such constants as to give about the same duration:

$$t = 1.085 \log^{10} i - .507.$$

As seen, in the ironclad transient the current curve is very much steeper in the range of high currents, where magnetic saturation is reached, but the current change is slower in the range of medium magnetic densities.

Thus, in ironclad transients very high-current values of short duration may occur, and such transients, as those of the starting current of alternating-current transformers, may therefore be of serious importance by their excessive current values.

An oscillogram of the voltage and current waves in an 11,000-kw. high-voltage 60-cycle three-phase transformer, when switching onto the generating station near the most unfavorable point of the wave, is reproduced in Fig. 30. As seen, an excessive current rush persists for a number of cycles, causing a distortion of the voltage wave, and the current waves remain unsymmetrical for many cycles.

The frequency f depends upon the length l_1 of the section of line in which the oscillation occurs. That is, the oscillations occurring in a transmission line or other circuit of distributed capacity have no definite frequency, but any frequency may occur, depending on the length of the circuit section which oscillates (provided that this circuit section is short compared with the entire length of the circuit, that is, the frequency high compared with the frequency which the oscillation would have if the entire line oscillates as a whole).

If l_1 is the oscillating line section, the wave length of this oscillation is four times the length

$$l_0 = 4 l_1. \quad (27)$$

This can be seen as follows:

At any point l of the oscillating line section l_1 , the effective power

$$p_0 = \text{avg } ei = 0 \quad (28)$$

is always zero, since voltage and current are 90 degrees apart.

The instantaneous power

$$p = ei, \quad (29)$$

however, is not zero, but alternately equal amounts of energy flow first one way, then the other way.

Across the ends of the oscillating section, however, no energy can flow, otherwise the oscillation would not be limited to this section. Thus at the two ends of the section, the instantaneous power, and thus either e or i , must continuously be zero.

Three cases thus are possible:

1. $e = 0$ at both ends of l_1 ;
2. $i = 0$ at both ends of l_1 ;
3. $e = 0$ at one end, $i = 0$ at the other end of l_1 .

In the third case, $i = 0$ at one end, $e = 0$ at the other end of the line section l_1 , the potential and current distribution in the line section l_1 must be as shown in Fig. 37, *A*, *B*, *C*, etc. That is, l_1 must be a quarter-wave or an odd multiple thereof.

If l_1 is a three-quarters wave, in Fig. 37*B*, at the two points *C* and *D* the power is also zero, that is, l_1 consists of three separate and independent oscillating sections, each of the length $\frac{l_1}{3}$; that is, the

where C = capacity = coefficient of energy storage by the voltage, in the dielectric field, and g = conductance = coefficient of power consumption by the voltage, as leakage conductance by the voltage, corona, dielectric hysteresis, etc.

Thus the transient of the spontaneous discharge of a condenser would be represented by

$$e = e_0 \epsilon^{-\frac{g}{C}t}. \quad (4)$$

Similar single-energy transients may occur in other systems. For instance, the transient by which a water jet approaches constant velocity when falling under gravitation through a resisting medium would have the duration

$$T = \frac{v_0}{g}, \quad (5)$$

where v_0 = limiting velocity, g = acceleration of gravity, and would be given by

$$v = v_0 \left(1 - \epsilon^{-\frac{t}{T}}\right). \quad (6)$$

In a system in which energy can be stored in two different forms, as for instance as magnetic and as dielectric energy in a circuit containing inductance and capacity, in addition to the gradual decrease of stored energy similar to that represented by the single-energy transient, a transfer of energy can occur between its two different forms.

Thus, if i = transient current, e = transient voltage (that is, the difference between the respective currents and voltages existing in the circuit as result of the previous circuit condition, and the values which should exist as result of the change of circuit conditions), then the total stored energy is

$$\left. \begin{aligned} W &= \frac{Li^2}{2} + \frac{Ce^2}{2}, \\ &= W_m + W_d. \end{aligned} \right\} \quad (7)$$

While the total energy W decreases by dissipation, W_m may be converted into W_d , or inversely.

Such an energy transfer may be periodic, that is, magnetic energy may change to dielectric and then back again; or unidirectional, that is, magnetic energy may change to dielectric (or inversely, dielectric to magnetic), but never change back again; but the

thus is

$$l_0 = vt_0 = \frac{1}{af}, \quad (32)$$

and, substituting (32) into (31), gives

$$a = \sigma_0, \quad (33)$$

or

$$v = \frac{1}{\sigma_0} = \frac{1}{\sqrt{L_0 C_0}}. \quad (34)$$

This gives a very important relation between inductance L_0 and capacity C_0 per unit length, and the velocity of propagation.

It allows the calculation of the capacity from the inductance,

$$C_0 = \frac{1}{v^2 L_0}, \quad (35)$$

and inversely. As in complex overhead structures the capacity usually is difficult to calculate, while the inductance is easily derived, equation (35) is useful in calculating the capacity by means of the inductance.

This equation (35) also allows the calculation of the mutual capacity, and thereby the static induction between circuits, from the mutual magnetic inductance.

The reverse equation,

$$L_0 = \frac{1}{v^2 C_0}, \quad (36)$$

is useful in calculating the inductance of cables from their measured capacity, and the velocity of propagation equation (13).

31. If l_1 is the length of a line, and its two ends are of different electrical character, as the one open, the other short-circuited, and thereby $i = 0$ at one end, $e = 0$ at the other end, the oscillation of this line is a quarter-wave or an odd multiple thereof.

The longest wave which may exist in this circuit has the wave length $l_0 = 4 l_1$, and therefore the period $t_0 = \sigma_0 l_0 = 4 \sigma_0 l_1$, that is, the frequency $f_0 = \frac{1}{4 \sigma_0 l_1}$. This is called the *fundamental* wave of oscillation. In addition thereto, all its odd multiples can exist as higher harmonics, of the respective wave lengths $\frac{l_0}{2k-1}$ and the frequencies $(2k-1)f_0$, where $k = 1, 2, 3 \dots$

The maximum transient voltage can thus be calculated from the maximum transient current:

$$e_0 = i_0 \sqrt{\frac{L}{C}} = i_0 z_0, \quad (10)$$

and inversely,

$$i_0 = e_0 \sqrt{\frac{C}{L}} = e_0 y_0. \quad (11)$$

This relation is very important, as frequently in double-energy transients one of the quantities e_0 or i_0 is given, and it is important to determine the other.

For instance, if a line is short-circuited, and the short-circuit current i_0 suddenly broken, the maximum voltage which can be induced by the dissipation of the stored magnetic energy of the short-circuit current is $e_0 = i_0 z_0$.

If one conductor of an ungrounded cable system is grounded, the maximum momentary current which may flow to ground is $i_0 = e_0 y_0$, where e_0 = voltage between cable conductor and ground.

If lightning strikes a line, and the maximum voltage which it may produce on the line, as limited by the disruptive strength of the line insulation against momentary voltages, is e_0 , the maximum discharge current in the line is limited to $i_0 = e_0 y_0$.

If L is high but C low, as in the high-potential winding of a high-voltage transformer (which winding can be considered as a circuit of distributed capacity, inductance, and resistance), z_0 is high and y_0 low. That is, a high transient voltage can produce only moderate transient currents, but even a small transient current produces high voltages. Thus reactances, and other reactive apparatus, as transformers, stop the passage of large oscillating currents, but do so by the production of high oscillating voltages.

Inversely, if L is low and C high, as in an underground cable, z_0 is low but y_0 high, and even moderate oscillating voltages produce large oscillating currents, but even large oscillating currents produce only moderate voltages. Thus underground cables are little liable to the production of high oscillating voltages. This is fortunate, as the dielectric strength of a cable is necessarily relatively much lower than that of a transmission line, due to the close proximity of the conductors in the former. A cable, therefore, when receiving the moderate or small oscillating currents which may originate in a transformer, gives only very low

usually are more conveniently resolved into the form of equation (19).

At extremely high frequencies $(2k - 1)f$, that is, for very large values of k , the successive harmonics are so close together that a very small variation of the line constants causes them to overlap, and as the line constants are not perfectly constant, but may vary slightly with the voltage, current, etc., it follows that at very high frequencies the line responds to any frequency, has no definite frequency of oscillation, but oscillations can exist of any frequency, provided this frequency is sufficiently high. Thus in long transmission lines, resonance phenomena can occur only with moderate frequencies, but not with frequencies of hundred thousands or millions of cycles.

32. The line constants r_0 , g_0 , L_0 , C_0 are given per unit length, as per cm., mile, 1000 feet, etc.

The most convenient unit of length, when dealing with transients in circuits of distributed capacity, is the velocity unit v .

That is, choosing as unit of length the distance of propagation in unit time, or 3×10^{10} cm. in overhead circuits, this gives $v = 1$, and therefore

$$\left. \begin{aligned} \sigma_0 &= \sqrt{L_0 C_0} = 1, \\ L_0 C_0 &= 1, \end{aligned} \right\} \quad (39)$$

or
$$C_0 = \frac{1}{L_0}; \quad L_0 = \frac{1}{C_0}.$$

That is, the capacity per unit of length, in velocity measure, is inversely proportional to the inductance. In this velocity unit of length, distances will be represented by λ .

Using this unit of length, σ_0 disappears from the equations of the transient.

This velocity unit of length becomes specially useful if the transient extends over different circuit sections, of different constants and therefore different wave lengths, as for instance an overhead line, the underground cable, in which the wave length is about one-half what it is in the overhead line ($\kappa = 4$) and coiled windings, as the high-potential winding of a transformer, in which the wave length usually is relatively short. In the velocity measure of length, the wave length becomes the same throughout all these circuit sections, and the investigation is thereby greatly simplified.

must be zero when the current is a maximum, and inversely; and if the current is represented by the cosine function, the voltage thus is represented by the sine function, that is,

$$e = e_0 \sin (\phi - \gamma), \quad (15)$$

where

$$e_1 = -e_0 \sin \gamma = \text{initial value of transient voltage.} \quad (16)$$

The frequency f is still unknown, but from the law of proportionality it follows that there must be a frequency, that is, the successive conversions between the two forms of energy must occur in equal time intervals, for this reason: If magnetic energy converts to dielectric and back again, at some moment the proportion between the two forms of energy must be the same again as at the starting moment, but both reduced in the same proportion by the power dissipation. From this moment on, the same cycle then must repeat with proportional, but proportionately lowered values.

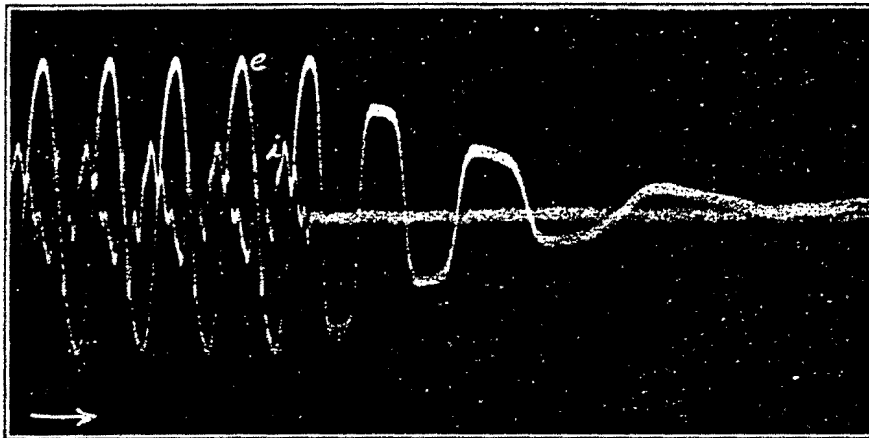

Fig. 31. — *CP10017.* — Oscillogram of Stationary Oscillation of Varying Frequency: Compound Circuit of Step-up Transformer and 28 Miles of 100,000-volt Transmission Line.

If, however, the law of proportionality does not exist, the oscillation may not be of constant frequency. Thus in Fig. 31 is shown an oscillogram of the voltage oscillation of the compound circuit consisting of 28 miles of 100,000-volt transmission line and the 2500-kw. high-potential step-up transformer winding, caused by switching transformer and 28-mile line by low-tension switches off a substation at the end of a 153-mile transmission line, at 88 kv. With decreasing voltage, the magnetic density in the transformer

beginning of time, that is, for $\phi = 0$, and by the values of i and e at all times t (or ϕ respectively) at the ends of the circuit, that is, for $\omega = 0$ and $\omega = \frac{\pi}{2}$.

For instance, if:

(a) The circuit is open at one end $\omega = 0$, that is, the current is zero at all times at this end. That is,

$$i = 0 \text{ for } \omega = 0;$$

the equations of i then must not contain the terms with $\cos \omega$, $\cos 2 \omega$, etc., as these would not be zero for $\omega = 0$. That is, it must be

$$\left. \begin{aligned} a_1 &= 0, & b_1 &= 0, \\ a_2 &= 0, & b_2 &= 0, \\ a_3 &= 0, & b_3 &= 0, \text{ etc.} \end{aligned} \right\} \quad (43)$$

The equation of i contains only the terms with $\sin \omega$, $\sin 2 \omega$, etc. Since, however, the voltage e is a maximum where the current i is zero, and inversely, at the point where the current is zero, the voltage must be a maximum; that is, the equations of the voltage must contain only the terms with $\cos \omega$, $\cos 2 \omega$, etc. Thus it must be

$$\left. \begin{aligned} c_1' &= 0, & d_1' &= 0, \\ c_2' &= 0, & d_2' &= 0, \\ c_3' &= 0, & d_3' &= 0, \text{ etc.} \end{aligned} \right\} \quad (44)$$

Substituting (43) and (44) into (42) gives

$$\left. \begin{aligned} i &= \epsilon^{-ut} \{c_1 \cos \phi + d_1 \sin \phi\} \sin \omega, \\ e &= \epsilon^{-ut} \{a_1' \cos \phi + b_1' \sin \phi\} \cos \omega \end{aligned} \right\} \quad (45)$$

and the higher harmonics hereof.

(b) If in addition to (a), the open circuit at one end $\omega = 0$, the line is short-circuited at the other end $\omega = \frac{\pi}{2}$, the voltage e must be zero at this latter end. $\cos \omega$, $\cos 3 \omega$, $\cos 5 \omega$, etc., become zero for $\omega = \frac{\pi}{2}$, but $\cos 2 \omega$, $\cos 4 \omega$, etc., are not zero for $\omega = \frac{\pi}{2}$, and the latter functions thus cannot appear in the expression of e .

as the expression of the frequency of the oscillation, where

$$\sigma = \sqrt{LC} \quad (20)$$

is a convenient abbreviation of the square root.

The transfer of energy between magnetic and dielectric thus occurs with a definite frequency $f = \frac{1}{2\pi\sigma}$, and the oscillation thus is a sine wave without distortion, as long as the law of proportionality applies. When this fails, the wave may be distorted, as seen on the oscillogram Fig. 31.

The equations of the *periodic part of the transient* can now be written down by substituting (13), (19), (14), and (16) into (12) and (15):

$$\begin{aligned} i &= i_0 \cos(\phi - \gamma) = i_0 \cos \gamma \cos \phi + i_0 \sin \gamma \sin \phi \\ &= i_1 \cos \frac{t}{\sigma} - e_1 \frac{i_0}{e_0} \sin \frac{t}{\sigma}, \end{aligned}$$

and by (11):

$$i = i_1 \cos \frac{t}{\sigma} - y_0 e_1 \sin \frac{t}{\sigma}, \quad (21)$$

and in the same manner:

$$e = e_1 \cos \frac{t}{\sigma} + z_0 i_1 \sin \frac{t}{\sigma}, \quad (22)$$

where e_1 is the initial value of transient voltage, i_1 the initial value of transient current.

B. Power dissipation.

27. In Fig. 32 are plotted as *A* the periodic component of the oscillating current i , and as *B* the voltage e , as *C* the stored magnetic energy $\frac{Li^2}{2}$, and as *D* the stored dielectric energy $\frac{Ce^2}{2}$.

As seen, the stored magnetic energy pulsates, with double frequency, $2f$, between zero and a maximum, equal to the total stored energy. The average value of the stored magnetic energy thus is one-half of the total stored energy, and the dissipation of magnetic energy thus occurs at half the rate at which it would occur if all the energy were magnetic energy; that is, the transient resulting from the power dissipation of the magnetic energy lasts twice as long as it would if all the stored energy were magnetic, or in other words, if the transient were a single (magnetic) energy

In these equations (50), d and a' are the maximum values of current and of voltage respectively, of the different harmonic waves. Between the maximum values of current, i_0 , and of voltage, e_0 , of a stationary oscillation exists, however, the relation

$$\frac{e_0}{i_0} = z_0 \sqrt{\frac{L}{C}},$$

where z_0 is the natural impedance or surge impedance. That is

$$a' = dz_0, \tag{51}$$

and substituting (51) into (50) gives

$$\left. \begin{aligned} i &= \epsilon^{-ut} \{ d_1 \sin \phi \sin \omega + d_3 \sin 3 \phi \sin 3 \omega + d_5 \sin 5 \phi \sin 5 \omega \\ &\quad + \dots \}, \\ e &= z_0 \epsilon^{-ut} \{ d_1 \cos \phi \cos \omega + d_3 \cos 3 \phi \cos 3 \omega + d_5 \cos 5 \phi \cos 5 \omega \\ &\quad + \dots \}. \end{aligned} \right\} \tag{52}$$

(d) If then the distribution of voltage e along the circuit is given at the moment of start of the transient, for instance, the voltage is constant and equals e_1 throughout the entire circuit at the starting moment $\phi = 0$ of the transient, this gives the relation, by substituting in (52),

$$e_1 = z_0 \epsilon^{-ut} \{ d_1 \cos \omega + d_3 \cos 3 \omega + d_5 \cos 5 \omega + \dots \}, \tag{53}$$

for all values of ω .

Herefrom then calculate the values of d_1, d_3, d_5 , etc., in the manner as discussed in "Engineering Mathematics," Chapter III.

as only half the energy is dielectric, the dissipation is half as rapid, that is, the dielectric transient has the duration

$$T_2 = 2 T_0' = \frac{2C}{g}, \quad (24)$$

and therefore adds the factor

$$k = e^{-\frac{t}{T_2}}$$

to the equations (21) and (22).

While these equations (21) and (22) constitute the periodic part of the phenomenon, the part which represents the dissipation of power is given by the factor

$$hk = e^{-\frac{t}{T_1}} e^{-\frac{t}{T_2}} = e^{-t\left(\frac{1}{T_1} + \frac{1}{T_2}\right)}. \quad (25)$$

The duration of the double-energy transient, T , thus is given by

$$\left. \begin{aligned} \frac{1}{T} &= \frac{1}{T_1} + \frac{1}{T_2}, \\ &= \frac{1}{2} \left(\frac{1}{T_0} + \frac{1}{T_0'} \right), \end{aligned} \right\} \quad (26)$$

and this is the *harmonic mean* of the duration of the single-energy magnetic and the single-energy dielectric transient.

It is, by substituting for T_0 and T_0' ,

$$\frac{1}{T} = \frac{1}{2} \left(\frac{r}{L} + \frac{g}{C} \right) = u, \quad (27)$$

where u is the abbreviation for the reciprocal of the duration of the double-energy transient.

Usually, the dissipation exponent of the double-energy transient

$$u = \frac{1}{2} \left(\frac{r}{L} + \frac{g}{C} \right)$$

is given as

$$\frac{r}{2L}.$$

This is correct only if $g = 0$, that is, the conductance, which represents the power dissipation resultant from the voltage (by leakage, dielectric induction and dielectric hysteresis, corona, etc.), is negligible. Such is the case in most power circuits and transmission lines, except at the highest voltages, where corona appears. It is not always the case in underground cables, high-potential

physical meaning a wave has, in which current and voltage are in phase with each other:

$$\left. \begin{aligned} i &= i_0 e^{-\alpha t} \cos(\phi \mp \omega - \gamma), \\ e &= e_0 e^{-\alpha t} \cos(\phi \mp \omega - \gamma). \end{aligned} \right\} \quad (4)$$

In this case the flow of power is

$$\begin{aligned} p &= ei, \\ &= e_0 i_0 e^{-2\alpha t} \cos^2(\phi \mp \omega - \gamma), \\ &= \frac{e_0 i_0}{2} e^{-2\alpha t} [1 + \cos 2(\phi \mp \omega - \gamma)], \end{aligned} \quad (5)$$

and the average flow of power is

$$\begin{aligned} p_0 &= \text{avg } p, \\ &= \frac{e_0 i_0}{2} e^{-2\alpha t}. \end{aligned} \quad (6)$$

Such a wave thus consists of a combination of a steady flow of power along the circuit, p_0 , and a pulsation or surge, p_1 , of the same nature as that of the standing wave (2):

$$p_1 = \frac{e_0 i_0}{2} e^{-2\alpha t} \cos 2(\phi \mp \omega - \gamma). \quad (7)$$

Such a flow of power along the circuit is called a *traveling wave*. It occurs very frequently. For instance, it may be caused if by a lightning stroke, etc., a quantity of dielectric energy is impressed

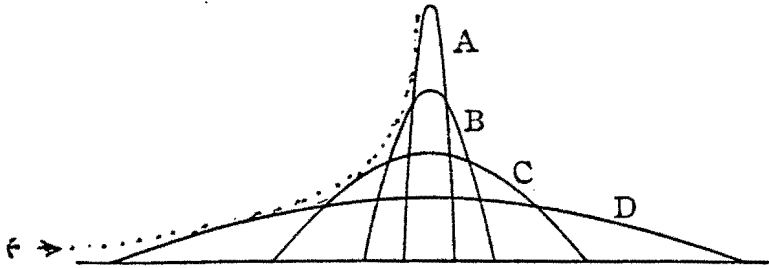

Fig. 39. — Starting of Impulse, or Traveling Wave.

upon a part of the circuit, as shown by curve *A* in Fig. 39, or if by a local short circuit a quantity of magnetic energy is impressed upon a part of the circuit. This energy then gradually distributes over the circuit, as indicated by the curves *B*, *C*, etc., of Fig. 39, that is, moves along the circuit, and the dissipation of the stored energy thus occurs by a flow of power along the circuit.

$$T_1 = \frac{2L}{r} = 0.001 \text{ sec.} = 1 \text{ millisecond,}$$

$$T_2 = \frac{2C}{g} = 0.0005 \text{ sec.} = 0.5 \text{ millisecond,}$$

$$T = \frac{1}{\frac{1}{T_1} + \frac{1}{T_2}} = 0.000333 \text{ sec.} = 0.33 \text{ millisecond;}$$

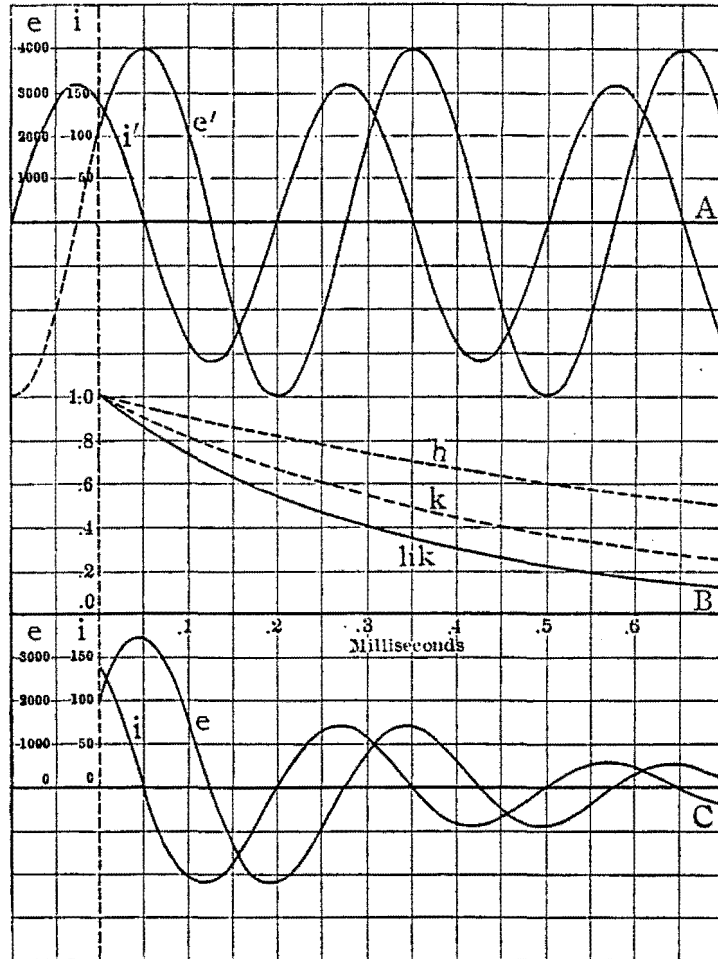

Fig. 33.

hence, substituted in equation (28),

$$\left. \begin{aligned} i &= \epsilon^{-3t} \{ 140 \cos 0.2 t - 80 \sin 0.2 t \}, \\ e &= \epsilon^{-3t} \{ 2000 \cos 0.2 t + 3500 \sin 0.2 t \}, \end{aligned} \right\}$$

where the time t is given in milliseconds.

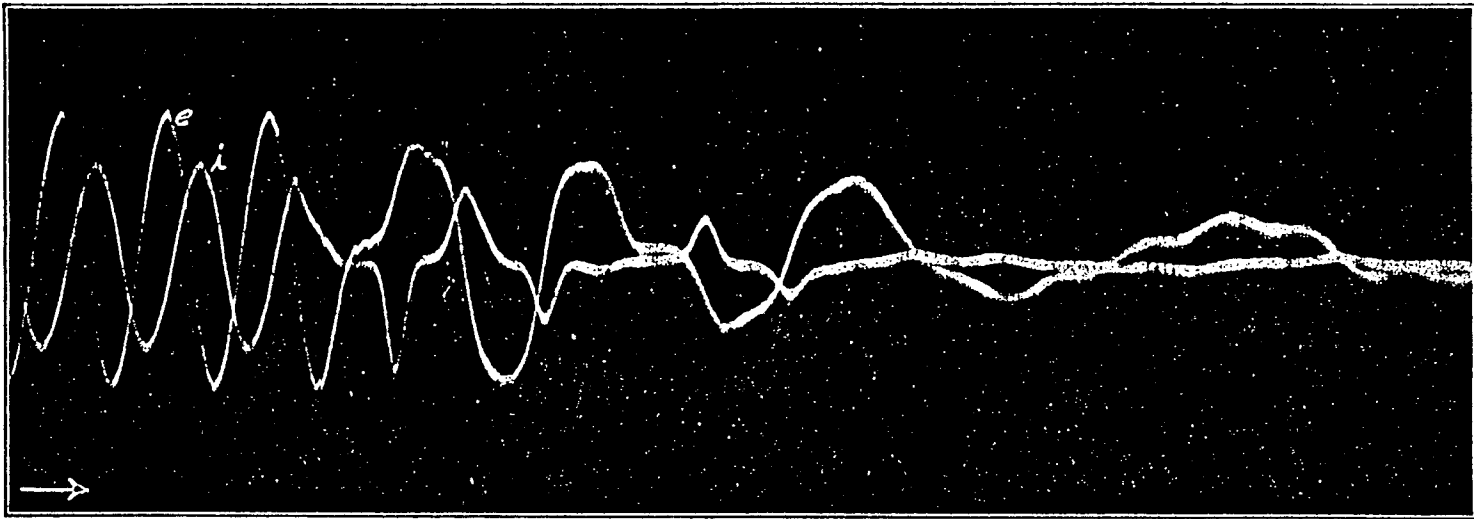

Fig. 41. — cd10045. — Oscillogram of Compound Circuit of 154 Miles 100,000-volt Transmission Line and High-tension Coils of 10,000-kw. Step-up Transformers, Switching off by Low-tension Switches. High-tension Current and Low-tension Voltage.

LECTURE VII.

LINE OSCILLATIONS.

28. In a circuit containing inductance and capacity, the transient consists of a periodic component, by which the stored energy surges between magnetic $\frac{Li^2}{2}$ and dielectric $\frac{Ce^2}{2}$, and a transient component, by which the total stored energy decreases.

Considering only the periodic component, the maximum value of magnetic energy must equal the maximum value of dielectric energy,

$$\frac{Li_0^2}{2} = \frac{Ce_0^2}{2}, \quad (1)$$

where i_0 = maximum value of transient current, e_0 = maximum value of transient voltage.

This gives the relation between e_0 and i_0 ,

$$\frac{e_0}{i_0} = \sqrt{\frac{L}{C}} = z_0 = \frac{1}{y_0}, \quad (2)$$

where z_0 is called the natural impedance or surge impedance, y_0 the natural or surge admittance of the circuit.

As the maximum of current must coincide with the zero of voltage, and inversely, if the one is represented by the cosine function, the other is the sine function; hence the periodic components of the transient are

$$\left. \begin{aligned} i_1 &= i_0 \cos(\phi - \gamma) \\ e_1 &= e_0 \sin(\phi - \gamma) \end{aligned} \right\} \quad (3)$$

where

$$\phi = 2\pi ft, \quad (4)$$

and

$$f = \frac{1}{2\pi\sqrt{LC}} \quad (5)$$

is the frequency of oscillation.

The dissipative or "transient" component is

$$hk = e^{-at}, \quad (6)$$

the rate ϵ^{-ut} , corresponding to the dissipation of the stored energy by ϵ^{-ut} , as indicated by A' in Fig. 42; while in the case (b) the power flow decreases faster, in case (c) slower, than corresponds to the energy dissipation, and is illustrated by B' and C' in Fig. 42.

(a) If the flow of power is constant in the direction of propagation, the equation would be

$$\begin{aligned} i &= i_0 \epsilon^{-ut} \cos(\phi - \omega - \gamma), \\ e &= e_0 \epsilon^{-ut} \cos(\phi - \omega - \gamma), \\ p_0 &= \frac{e_0 i_0}{2} \epsilon^{-2ut}. \end{aligned} \quad (9)$$

In this case there must be a continuous power supply at the one end, and power abstraction at the other end, of the circuit or circuit section in which the flow of power is constant. This could occur approximately only in special cases, as in a circuit section of medium rate of power dissipation, u , connected between a section of low- and a section of high-power dissipation. For instance, if as illustrated in Fig. 43 we have a transmission line

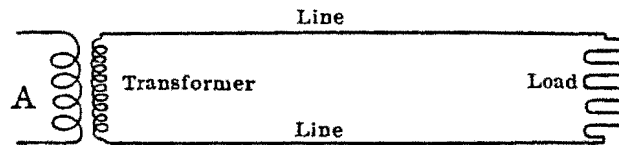

Fig. 43. — Compound Circuit.

connecting the step-up transformer with a load on the step-down end, and the step-up transformer is disconnected from the generating system, leaving the system of step-up transformer, line, and load to die down together in a stationary oscillation of a compound circuit, the rate of power dissipation in the transformer then is much lower, and that in the load may be greater, than the average rate of power dissipation of the system, and the transformer will supply power to the rest of the oscillating system, the load receive power. If then the rate of power dissipation of the line u should happen to be exactly the average, u_0 , of the entire system, power would flow from the transformer over the line into the load, but in the line the flow of power would be uniform, as the line neither receives energy from nor gives off energy to the rest of the system, but its stored energy corresponds to its rate of power dissipation.

are the current and voltage at the point A , this oscillation will appear at a point B , at distance l from A , at a moment of time later than at A by the time of propagation t_1 from A to B , if the oscillation is traveling from A to B ; that is, in the equation (11), instead of t the time $(t - t_1)$ enters.

Or, if the oscillation travels from B to A , it is earlier at B by the time t_1 ; that is, instead of the time t , the value $(t + t_1)$ enters the equation (11). In general, the oscillation at A will appear at B , and the oscillation at B will appear at A , after the time t_1 ; that is, both expressions of (11), with $(t - t_1)$ and with $(t + t_1)$, will occur.

The general form of the line oscillation thus is given by substituting $(t \mp t_1)$ instead of t into the equations (11), where t_1 is the time of propagation over the distance l .

If v = velocity of propagation of the electric field, which in air, as with a transmission line, is approximately

$$v = 3 \times 10^{10}, \quad (12)$$

and in a medium of permeability μ and permittivity (specific capacity) κ is

$$v = \frac{3 \times 10^{10}}{\sqrt{\mu\kappa}}, \quad (13)$$

and we denote

$$a = \frac{1}{v}, \quad (14)$$

then

$$t_1 = al; \quad (15)$$

and if we denote

$$2\pi ft_1 = \omega = 2\pi fal, \quad (16)$$

we get, substituting $t \mp t_1$ for t and $\phi \mp \omega$ for ϕ into the equation (11), the equations of the line oscillation:

$$\left. \begin{aligned} i &= ce^{-\alpha t} \cos(\phi \mp \omega - \gamma) \\ e &= z_0 c e^{-\alpha t} \sin(\phi \mp \omega - \gamma) \end{aligned} \right\}. \quad (17)$$

In these equations,

$$\left. \begin{aligned} \phi &= 2\pi ft \\ \omega &= 2\pi fal \end{aligned} \right\} \quad (18)$$

is the time angle, and

is the space angle, and $c = c_0 e^{\pm \alpha l}$ is the maximum value of current, $z_0 c$ the maximum value of voltage at the point l .

the average power then is

$$\begin{aligned} p_0 &= \text{avg } ei, \\ &= \frac{e_0 i_0}{2} \epsilon^{-2(u-s)t} \epsilon^{-2s\lambda} = \frac{e_0 i_0}{2} \epsilon^{-2ut} \epsilon^{+2s(t-\lambda)}. \end{aligned} \quad (12)$$

Both forms of the expressions of i , e , and p_0 of equations (11) and (12) are of use. The first form shows that the wave decreases slower with the time t , but decreases with the distance λ . The second form shows that the distance λ enters the equation only in the form $t - \lambda$ and $\phi - \omega$ respectively, and that thus for a constant value of $t - \lambda$ the decrement is ϵ^{-2ut} , that is, in the direction of propagation the energy dies out by the power dissipation constant u .

Equations (10) to (12) apply to the case, when the direction of propagation, that is, of wave travel, is toward increasing λ . For a wave traveling in opposite direction, the sign of λ and thus of ω is reversed.

(c) If the flow of power increases along the line, more power leaves every line element than enters it; that is, the line element is drained of its stored energy by the passage of the wave, and thus the transient dies down with the time at a greater rate than corresponds to the power dissipation by r and g . That is, not all the stored energy of the line elements supplies the power which is being dissipated in the line element, but a part of the energy leaves the line element in increasing the power which flows along the line. The rate of dissipation thus is increased, and instead of u , $(u + s)$ enters the equation. That is, the exponential time decrement is

$$\epsilon^{-(u+s)t}, \quad (13)$$

but inversely, along the line λ the power flow increases, that is, the intensity of the wave increases, by the same factor $\epsilon^{+s\lambda}$, or rather, the wave decreases along the line at a slower rate than corresponds to the power dissipation.

The equations then become:

$$\left. \begin{aligned} i &= i_0 \epsilon^{-(u+s)t} \epsilon^{+s\lambda} \cos(\phi - \omega - \gamma) = i_0 \epsilon^{-ut} \epsilon^{-s(t-\lambda)} \cos(\phi - \omega - \gamma), \\ e &= e_0 \epsilon^{-(u+s)t} \epsilon^{+s\lambda} \cos(\phi - \omega - \gamma) = e_0 \epsilon^{-ut} \epsilon^{-s(t-\lambda)} \cos(\phi - \omega - \gamma), \end{aligned} \right\} (14)$$

and the average power is

$$p_0 = \frac{e_0 i_0}{2} \epsilon^{-2(u+s)t} \epsilon^{+2s\lambda} = \frac{e_0 i_0}{2} \epsilon^{-2ut} \epsilon^{-2s(t-\lambda)}, \quad (15)$$

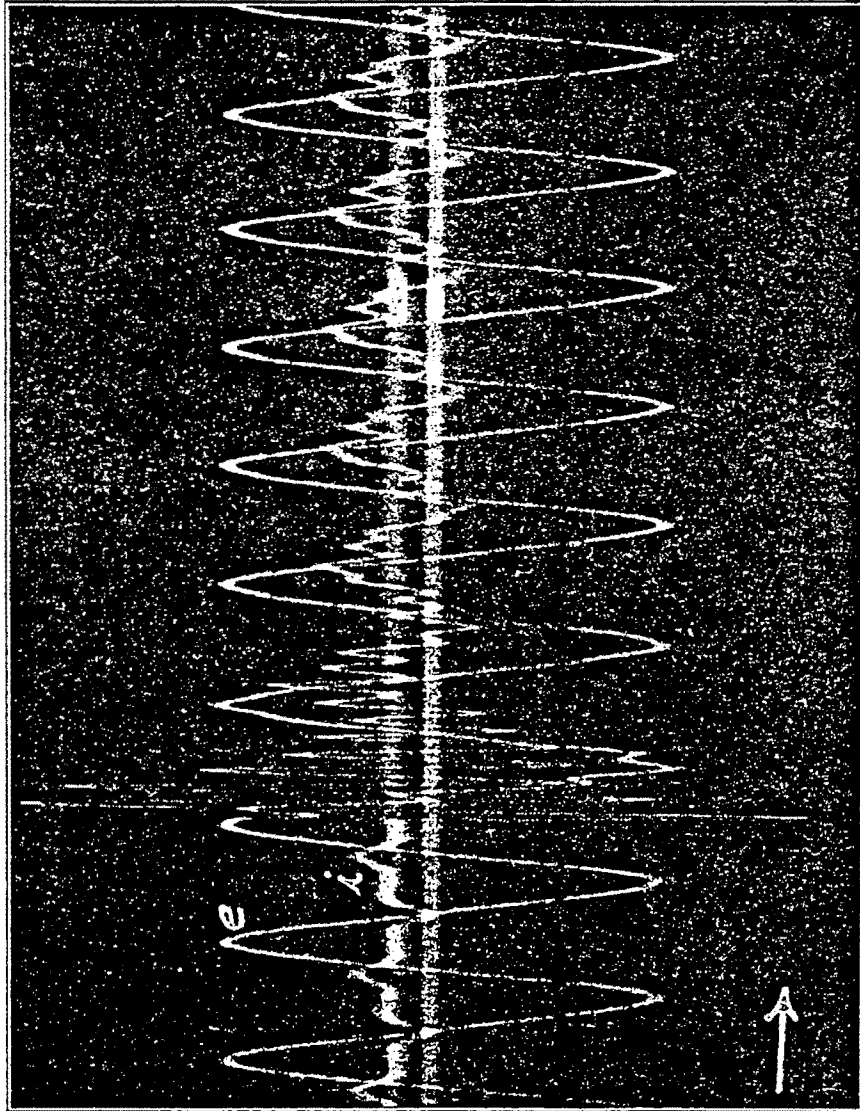

Fig. 35. — *oscillogram of Starting Oscillation of 28 Miles of 100,000-volt Transmission Line:*

increase with the time, which in general is not possible; as the transient must decrease with the time, by the power dissipation in r and g .

Standing waves and traveling waves, in which the coefficient in the exponent of the time exponential is positive, that is, the wave increases with the time, may, however, occur in electric circuits in which the wave is supplied with energy from some outside source, as by a generating system flexibly connected (electrically) through an arc. Such waves then are "cumulative oscillations." They may either increase in intensity indefinitely, that is, up to destruction of the circuit insulation, or limit themselves by the power dissipation increasing with the increasing intensity of the oscillation, until it becomes equal to the power supply. Such oscillations, which frequently are most destructive ones, are met in electric systems as "arcing grounds," "grounded phase," etc. They are frequently called "undamped oscillations," and as such find a use in wireless telegraphy and telephony. Thus far, the only source of cumulative oscillation seems to be an energy supply over an arc, especially an unstable arc. In the self-limiting cumulative oscillation, the so-called damped oscillation, the transient becomes a permanent phenomenon. Our theoretical knowledge of the cumulative oscillations thus far is rather limited, however.

An oscillogram of a "grounded phase" on a 154-mile three-phase line, at 82 kilovolts, is given in Figs. 44 and 45. Fig. 44 shows current and voltage at the moment of formation of the ground; Fig. 45 the same one minute later, when the ground was fully developed.

An oscillogram of a cumulative oscillation in a 2500-kw. 100,000-volt power transformer (60-cycle system) is given in Fig. 46. It is caused by switching off 28 miles of line by high-tension switches, at 88 kilovolts. As seen, the oscillation rapidly increases in intensity, until it stops by the arc extinguishing, or by the destruction of the transformer.

Of special interest is the limiting case,

$$-s = u;$$

in this case, $u + s = 0$, and the exponential function of time vanishes, and current and voltage become

$$\left. \begin{aligned} i &= i_0 e^{\pm s\lambda} \cos(\phi \mp \omega - \gamma), \\ e &= e_0 e^{\pm s\lambda} \cos(\phi \mp \omega - \gamma), \end{aligned} \right\} \quad (18)$$

Instead of L and C , thus enter into the equation of the double-energy oscillation of the line the values $\frac{2L}{\pi}$ and $\frac{2C}{\pi}$. *

In the same manner, instead of the total resistance r and the total conductance g , the values $\frac{2r}{\pi}$ and $\frac{2g}{\pi}$ appear. *

The values of z_0 , y_0 , u , ϕ , and ω are not changed hereby.

The frequency f , however, changes from the value corresponding to the circuit of massed capacity, $f = \frac{1}{2\pi\sqrt{LC}}$, to the value

$$f = \frac{1}{4\sqrt{LC}}.$$

Thus the frequency of oscillation of a transmission line is

$$f = \frac{1}{4\sqrt{LC}} = \frac{1}{4\sigma}, \quad (20)$$

where

$$\sigma = \sqrt{LC}. \quad (21)$$

If l_1 is the length of the line, or of that piece of the line over which the oscillation extends, and we denote by

$$L_0, C_0, r_0, g_0 \quad (22)$$

the inductance, capacity, resistance, and conductance per unit length of line, then

$$u = \frac{1}{2} \left(\frac{r_0}{L_0} + \frac{g_0}{C_0} \right); \quad (23)$$

that is, the rate of decrease of the transient is independent of the length of the line, and merely depends on the line constants per unit length.

It then is

$$\sigma = l_1 \sigma_0, \quad (24)$$

where

$$\sigma_0 = \sqrt{L_0 C_0} \quad (25)$$

is a constant of the line construction, but independent of the length of the line.

The frequency then is

$$f = \frac{1}{4l_1\sigma_0}. \quad (26)$$

* ERROR IN STEINMETZ ANALYSIS, FOR WINDINGS, $\frac{2}{\pi}$ BECOMES;
 $\frac{L}{\pi}, \frac{R}{\pi}, \frac{C}{\pi}, \frac{G}{\pi}$

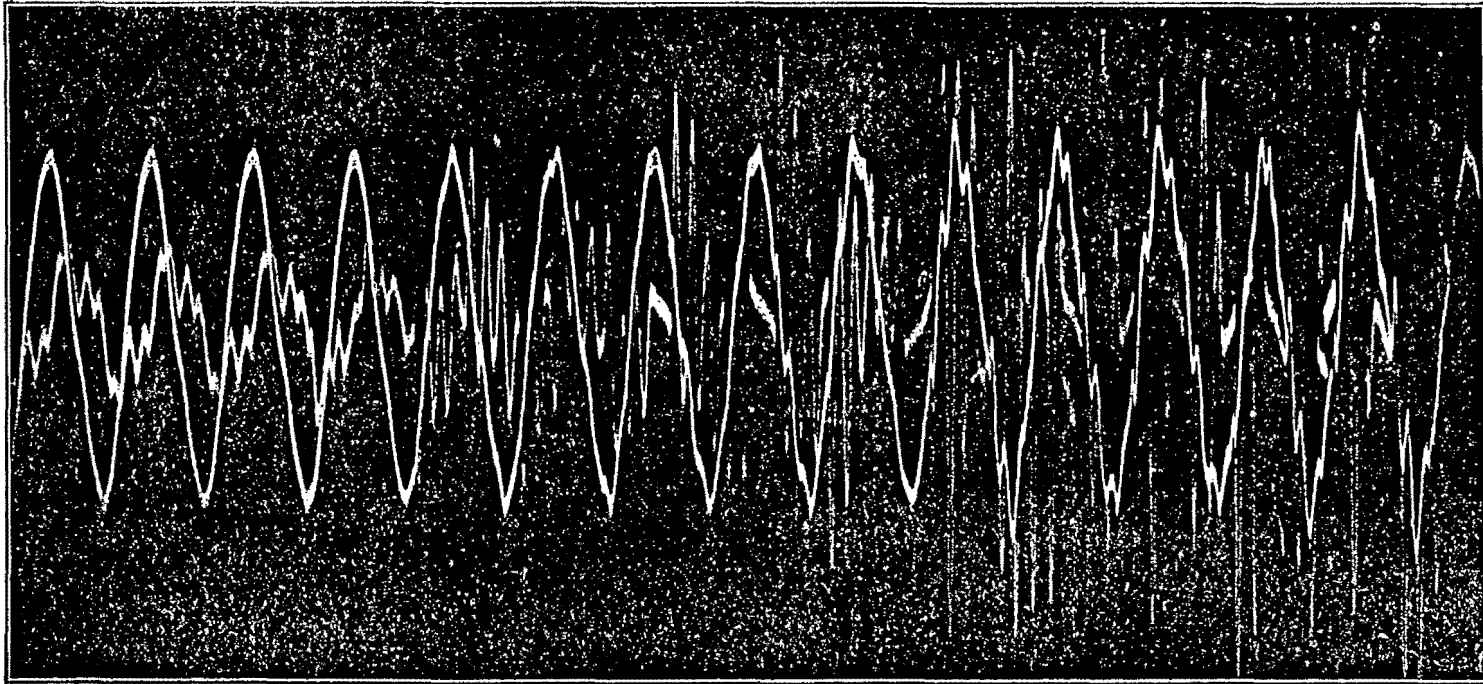

Fig. 46. — cd10001. — Oscillogram of Cumulative Oscillation in High-potential Coil of 2500-kw. Step-up Transformer Caused by Disconnecting 28 Miles of 100,000-volt Transmission Line; High-tension Switching.

unit of oscillation is $\frac{l_1}{3}$, or also a quarter-wave. The same is the case in Fig. 37C, etc.

In the case 2, $i = 0$ at both ends of the line, the current and voltage distribution are as sketched in Fig. 38, A, B, C, etc.

That is, in A, the section l_1 is a half-wave, but the middle, C, of l_1 is a node or point of zero power, and the oscillating unit again is a quarter-wave. In the same way, in Fig. 38B, the section l_1 consists of 4 quarter-wave units, etc.

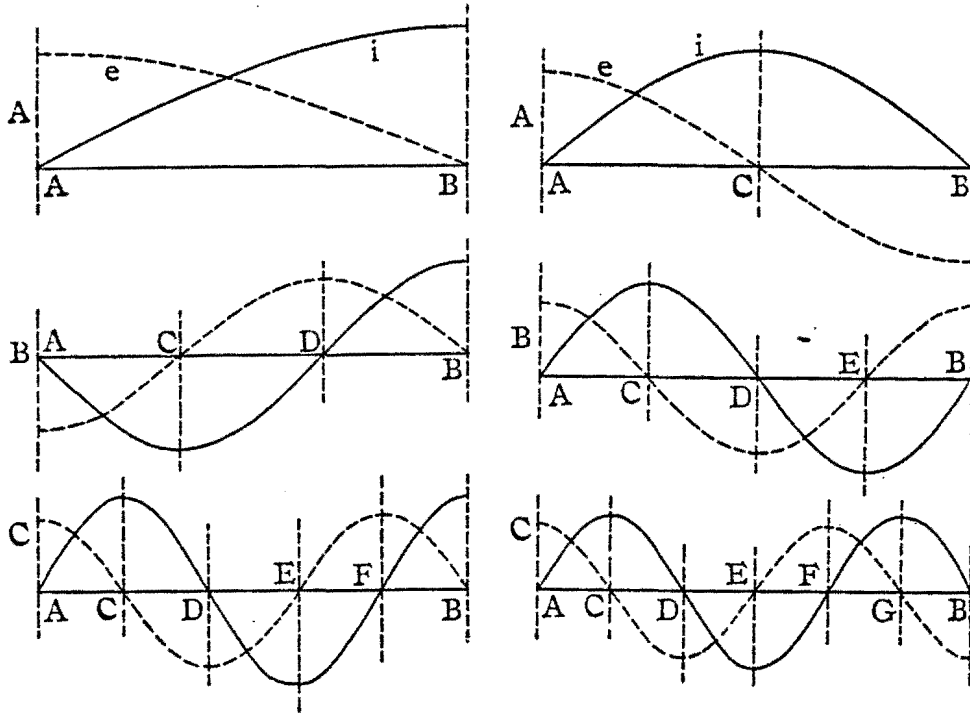

Fig. 37.

Fig. 38.

The same applies to case 1, and it thus follows that the wave length l_0 is four times the length of the oscillation l_1 .

30. Substituting $l_0 = 4 l_1$ into (26) gives as the frequency of oscillation

$$f = \frac{1}{l_0 \sigma_0} \tag{30}$$

However, if $f =$ frequency, and $v = \frac{1}{\alpha}$, velocity of propagation, the wave length l_0 is the distance traveled during one period:

$$t_0 = \frac{1}{f} = \text{period}, \tag{31}$$

When traveling waves and stationary waves occur simultaneously, very often the traveling wave precedes the stationary wave.

The phenomenon may start with a traveling wave or impulse, and this, by reflection at the ends of the circuit, and combination of the reflected waves and the main waves, gradually changes to a stationary wave. In this case, the traveling wave has the same frequency as the stationary wave resulting from it. In Fig. 47 is shown the reproduction of an oscillogram of the formation of a stationary oscillation in a transmission line by the repeated re-

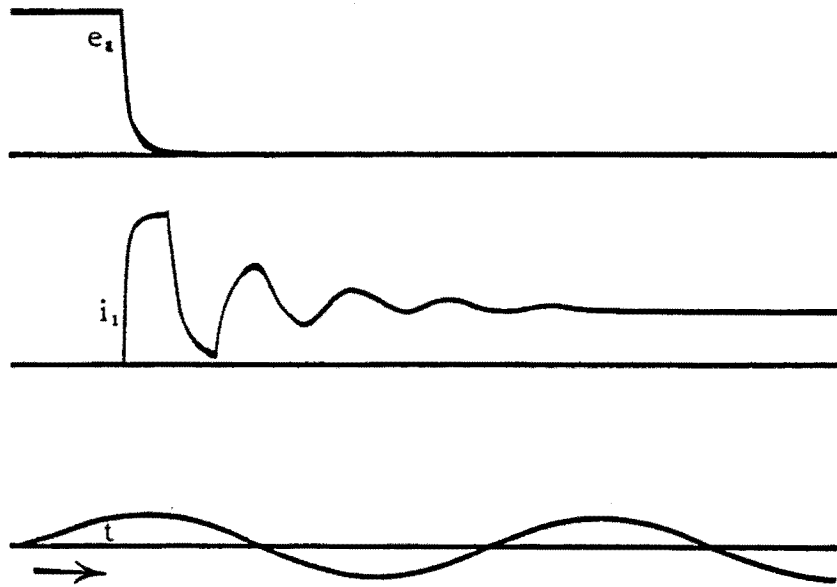

Fig. 47. — CD11168. — Reproduction of an Oscillogram of Stationary Line Oscillation by Reflection of Impulse from Ends of Line. (The lowest curve gives a 60-cycle current as time measure.)

flection from the ends of the line of the single impulse caused by short circuiting the energized line at one end. In the beginning of a stationary oscillation of a compound circuit, that is, a circuit comprising sections of different constants, traveling waves frequently occur, by which the energy stored magnetically or dielectrically in the different circuit sections adjusts itself to the proportion corresponding to the stationary oscillation of the complete circuit. Such traveling waves then are local, and therefore of much higher frequency than the final oscillation of the complete circuit, and thus die out at a faster rate. Occasionally they are shown by the oscillograph as high-frequency oscillations intervening between

If then ϕ denotes the time angle and ω the distance angle of the fundamental wave, that is, $\phi = 2\pi$ represents a complete cycle and $\omega = 2\pi$ a complete wave length of the fundamental wave, the time and distance angles of the higher harmonics are

$$\begin{aligned} &3\phi, 3\omega, \\ &5\phi, 5\omega, \\ &7\phi, 7\omega, \text{ etc.} \end{aligned}$$

A complex oscillation, comprising waves of all possible frequencies, thus would have the form

$$\begin{aligned} &a_1 \cos(\phi \mp \omega - \gamma_1) + a_3 \cos 3(\phi \mp \omega - \gamma_3) \\ &+ a_5 \cos 5(\phi \mp \omega - \gamma_5) + \dots, \end{aligned} \quad (37)$$

and the length l_1 of the line then is represented by the angle $\omega = \frac{\pi}{2}$, and the oscillation called a *quarter-wave oscillation*.

If the two ends of the line l_1 have the same electrical characteristics, that is, $e = 0$ at both ends, or $i = 0$, the longest possible wave has the length $l_0 = 2l_1$, and the frequency

$$f_0 = \frac{1}{\sigma_0 l_0} = \frac{1}{2\sigma_0 l_1},$$

or any multiple (odd or even) thereof.

If then ϕ and ω again represent the time and the distance angles of the fundamental wave, its harmonics have the respective time and distance angles

$$\begin{aligned} &2\phi, 2\omega, \\ &3\phi, 3\omega, \\ &4\phi, 4\omega, \text{ etc.} \end{aligned}$$

A complex oscillation then has the form

$$\begin{aligned} &a_1 \cos(\phi \mp \omega - \gamma_1) + a_2 \cos 2(\phi \mp \omega - \gamma_2) \\ &+ a_3 \cos 3(\phi \mp \omega - \gamma_3) + \dots, \end{aligned} \quad (38)$$

and the length l_1 of the line is represented by angle $\omega_1 = \pi$, and the oscillation is called a *half-wave oscillation*.

The half-wave oscillation thus contains even as well as odd harmonics, and thereby may have a wave shape, in which one half wave differs from the other.

Equations (37) and (38) are of the form of equation (17), but

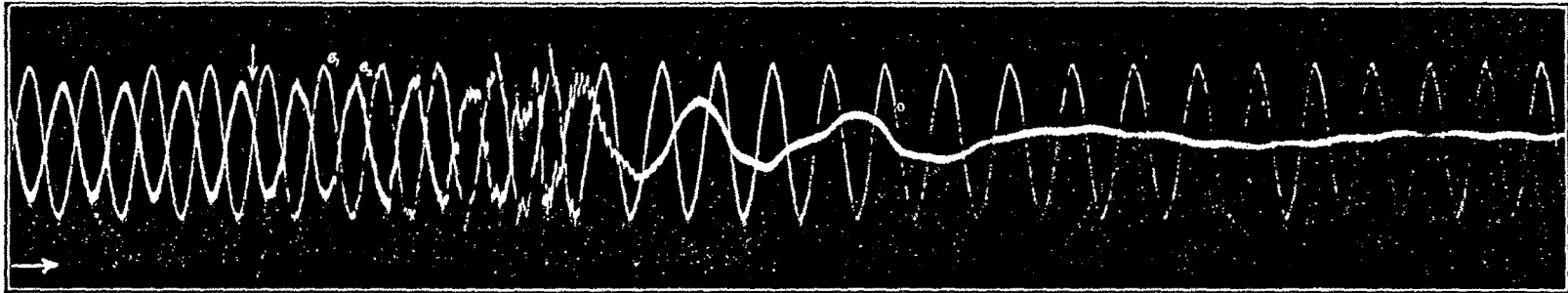

Fig. 48B. — CD10049. — Oscillogram of High-frequency Oscillation Preceding Low-frequency Oscillation of Compound Circuit Caused by Switching 154 miles of 100,000 Volts Transmission Line and Step-down Transformer off another 154 Miles of 100,000 Volts Line; High-tension Switching.

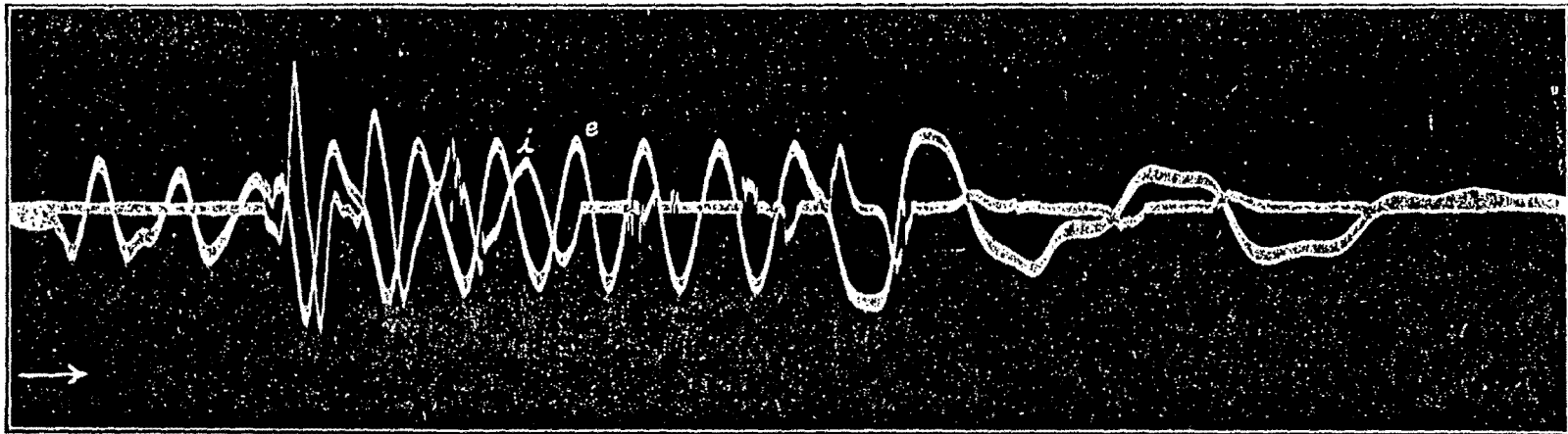

Fig. 49. — CD10036. — Oscillogram of Oscillation of Compound Circuit Consisting of 154 Miles of 100,000 Volts Line and Step-up Transformer; Connecting and Disconnecting by Low-tension Switches. High-tension Current and Low-tension Voltage.

Substituting $\sigma_0 = 1$ in equations (30) and (31) gives

$$\left. \begin{aligned} t_0 &= \lambda_0, \\ f &= \frac{1}{\lambda_0}, \\ \phi &= 2\pi ft = \frac{2\pi t}{\lambda_0}, \\ \omega &= 2\pi f\lambda = \frac{2\pi\lambda}{\lambda_0}, \end{aligned} \right\} \quad (40)$$

and the natural impedance of the line then becomes, in velocity measure,

$$z_0 = \sqrt{\frac{L_0}{C_0}} = L_0 = \frac{1}{C_0} = \frac{1}{y_0} = \frac{e_0}{i_0} \quad (41)$$

where $e_0 =$ maximum voltage, $i_0 =$ maximum current.

That is, the natural impedance is the inductance, and the natural admittance is the capacity, per velocity unit of length, and is the main characteristic constant of the line.

The equations of the current and voltage of the line oscillation then consist, by (19), of trigonometric terms

$$\begin{aligned} &\cos \phi \cos \omega, \\ &\sin \phi \cos \omega, \\ &\cos \phi \sin \omega, \\ &\sin \phi \sin \omega, \end{aligned}$$

multiplied with the transient, ϵ^{-ut} , and would thus, in the most general case, be given by an expression of the form

$$\left. \begin{aligned} i &= \epsilon^{-ut} \{ a_1 \cos \phi \cos \omega + b_1 \sin \phi \cos \omega + c_1 \cos \phi \sin \omega \\ &\quad + d_1 \sin \phi \sin \omega \}, \\ e &= \epsilon^{-ut} \{ a_1' \cos \phi \cos \omega + b_1' \sin \phi \cos \omega + c_1' \cos \phi \sin \omega \\ &\quad + d_1' \sin \phi \sin \omega \}, \end{aligned} \right\} \quad (42)$$

and its higher harmonics, that is, terms, with

$$\begin{aligned} &2\phi, 2\omega, \\ &3\phi, 3\omega, \\ &4\phi, 4\omega, \text{ etc.} \end{aligned}$$

In these equations (42), the coefficients $a, b, c, d, a', b', c', d'$ are determined by the *terminal conditions* of the problem, that is, by the values of i and e at all points of the circuit ω , at the

Such simple traveling waves frequently are called "*impulses*."

When such an impulse passes along the line, at any point of the line, the wave energy is zero up to the moment where the wave front of the impulse arrives. The energy then rises, more or less rapidly, depending on the steepness of the wave front, reaches a maximum, and then decreases again, about as shown in Fig. 50. The impulse thus is the combination of two waves,



Fig. 50. — Traveling Wave.

one, which decreases very rapidly, $e^{-(u+s)t}$, and thus preponderates in the beginning of the phenomenon, and one, which decreases slowly, $e^{-(u-s)t}$. Hence it may be expressed in the form:

$$p_0 = a_1 e^{-2(u+s)t} e^{+2s\lambda} + a_2 e^{-2(u-s)t} e^{-2s\lambda}, \quad (20)$$

where the value of the power-transfer constant s determines the "steepness of wave front."

Figs. 51 to 53 show oscillograms of the propagation of such an impulse over an (artificial) transmission line of 130 miles,* of the constants:

$$\begin{aligned} r &= 93.6 \text{ ohms,} \\ L &= 0.3944 \text{ henrys,} \\ C &= 1.135 \text{ microfarads,} \end{aligned}$$

thus of surge impedance $z_0 = \sqrt{\frac{L}{C}} = 590$ ohms.

The impulse is produced by a transformer charge.†

Its duration, as measured from the oscillograms, is $T_0 = 0.0036$ second.

In Fig. 51, the end of the transmission line was connected to a noninductive resistance equal to the surge impedance, so as to

* For description of the line see "Design, Construction, and Test of an Artificial Transmission Line," by J. H. Cunningham, Proceedings A.I.E.E., January, 1911.

† In the manner as described in "Disruptive Strength of Air and Oil with Transient Voltages," by J. L. R. Hayden and C. P. Steinmetz, Transactions A.I.E.E., 1910, page 1125. The magnetic energy of the transformer is, however, larger, about 4 joules, and the transformer contained an air gap, to give constant inductance.

That is, the voltage e can contain no even harmonics. If, however, the voltage contains no even harmonics, the current produced by this voltage also can contain no even harmonics. That is, it must be

$$\left. \begin{aligned} c_2 = 0, \quad d_2 = 0, \quad a_2' = 0, \quad b_2' = 0, \\ c_4 = 0, \quad d_4 = 0, \quad a_4' = 0, \quad b_4' = 0, \\ c_6 = 0, \quad d_6 = 0, \quad a_6' = 0, \quad b_6' = 0, \quad \text{etc.} \end{aligned} \right\} \quad (46)$$

The complete expression of the stationary oscillation in a circuit open at the end $\omega = 0$ and short-circuited at the end $\omega = \frac{\pi}{2}$ thus would be

$$\left. \begin{aligned} i &= \epsilon^{-ut} \{ (c_1 \cos \phi + d_1 \sin \phi) \sin \omega + (c_3 \cos 3 \phi + d_3 \sin 3 \phi) \\ &\quad \sin 3 \omega + \dots \}, \\ e &= \epsilon^{-ut} \{ (a_1' \cos \phi + b_1' \sin \phi) \cos \omega + (a_3' \cos 3 \phi + b_3' \sin 3 \phi) \\ &\quad \cos 3 \omega + \dots \}. \end{aligned} \right\} \quad (47)$$

(c) Assuming now as instance that, in such a stationary oscillation as given by equation (47), the current in the circuit is zero at the starting moment of the transient for $\phi = 0$. Then the equation of the current can contain no terms with $\cos \phi$, as these would not be zero for $\phi = 0$.

That is, it must be

$$\left. \begin{aligned} c_1 = 0, \\ c_3 = 0, \\ c_5 = 0, \quad \text{etc.} \end{aligned} \right\} \quad (48)$$

At the moment, however, when the current is zero, the voltage of the stationary oscillation must be a maximum. As $i = 0$ for $\phi = 0$, at this moment the voltage e must be a maximum, that is, the voltage wave can contain no terms with $\sin \phi$, $\sin 3 \phi$, etc. This means

$$\left. \begin{aligned} b_1' = 0, \\ b_3' = 0, \\ b_5' = 0, \quad \text{etc.} \end{aligned} \right\} \quad (49)$$

Substituting (48) and (49) into equation (47) gives

$$\left. \begin{aligned} i &= \epsilon^{-ut} \{ d_1 \sin \phi \sin \omega + d_3 \sin 3 \phi \sin 3 \omega + d_5 \sin 5 \phi \sin 5 \omega \\ &\quad + \dots \}, \\ e &= \epsilon^{-ut} \{ a_1' \cos \phi \cos \omega + a_3' \cos 3 \phi \cos 3 \omega + a_5' \cos 5 \phi \cos 5 \omega \\ &\quad + \dots \}. \end{aligned} \right\} \quad (50)$$

give no reflection. The upper curve shows the voltage of the impulse at the beginning, the middle curve in the middle, and the lower curve at the end of the line.

Fig. 52 gives the same three voltages, with the line open at the end. This oscillogram shows the repeated reflections of the voltage impulse from the ends of the line,—the open end and the transformer inductance at the beginning. It also shows the increase of voltage by reflection.

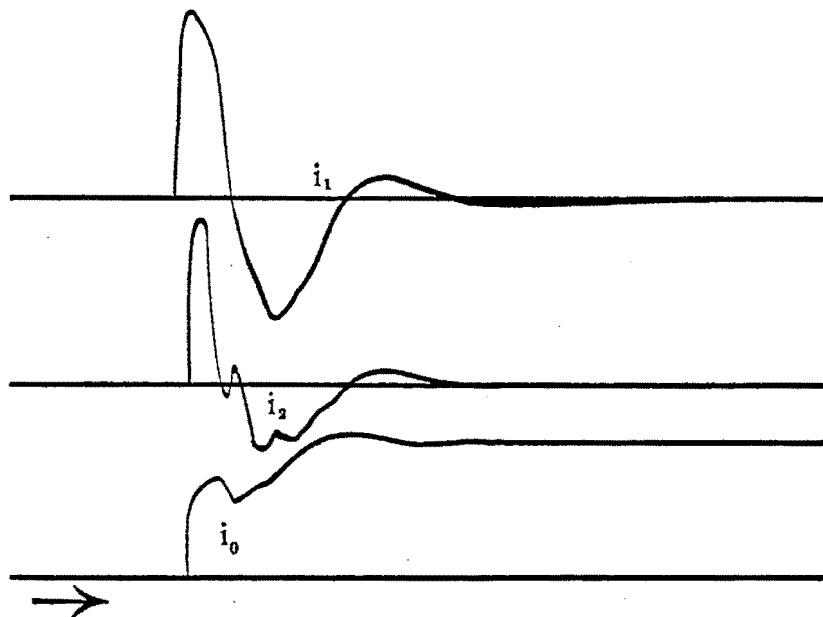

Fig. 53. — CD11153. — Reproduction of Oscillogram of Propagation of Impulse Over Transmission Line; Reflection from Open End of Line. Current.

Fig. 53 gives the current impulses at the beginning and the middle of the line, corresponding to the voltage impulses in Fig. 52, together with the primary current of the transformer, i_0 . This oscillogram shows the reversals of current by reflection, and the formation of a stationary oscillation by the successive reflections of the traveling wave from the ends of the line.

LECTURE VIII.

TRAVELING WAVES.

33. In a stationary oscillation of a circuit having uniformly distributed capacity and inductance, that is, the transient of a circuit storing energy in the dielectric and magnetic field, current and voltage are given by the expression

$$\left. \begin{aligned} i &= i_0 e^{-ut} \cos(\phi \mp \omega - \gamma), \\ e &= e_0 e^{-ut} \sin(\phi \mp \omega - \gamma), \end{aligned} \right\} \quad (1)$$

where ϕ is the time angle, ω the distance angle, u the exponential decrement, or the "power-dissipation constant," and i_0 and e_0 the maximum current and voltage respectively.

The power flow at any point of the circuit, that is, at any distance angle ω , and at any time t , that is, time angle ϕ , then is

$$\begin{aligned} p &= ei, \\ &= e_0 i_0 e^{-2ut} \cos(\phi \mp \omega - \gamma) \sin(\phi \mp \omega - \gamma), \\ &= \frac{e_0 i_0}{2} e^{-2ut} \sin 2(\phi \mp \omega - \gamma), \end{aligned} \quad (2)$$

and the average power flow is

$$\begin{aligned} P_0 &= \text{avg } p, \\ &= 0. \end{aligned} \quad (3)$$

Hence, in a stationary oscillation, or standing wave of a uniform circuit, the average flow of power, p_0 , is zero, and no power flows along the circuit, but there is a surge of power, of double frequency. That is, power flows first one way, during one-quarter cycle, and then in the opposite direction, during the next quarter-cycle, etc.

Such a transient wave thus is analogous to the permanent wave of reactive power.

As in a stationary wave, current and voltage are in quadrature with each other, the question then arises, whether, and what

power-dissipation constant of the circuit, and u that of any section, this section must have a second exponential time decrement,

$$s = u_0 - u, \tag{2}$$

which represents power transfer from the section to other sections, or, if s is negative, power received from other sections. The oscillation of every individual section thus is a traveling wave, with a power-transfer constant s .

As u_0 is the average dissipation constant, that is, an average of the power-dissipation constants u of all the sections, and $s = u_0 - u$ the power-transfer constant, some of the s must be positive, some negative.

In any section in which the power-dissipation constant u is less than the average u_0 of the entire circuit, the power-transfer constant s is positive; that is, the wave, passing over this section, increases in intensity, builds up, or in other words, gathers energy, which it carries away from this section into other sections. In any section in which the power-dissipation constant u is greater than the average u_0 of the entire circuit, the power-transfer constant s is negative; that is, the wave, passing over this section, decreases in intensity and thus in energy, or in other words, leaves some of its energy in this section, that is, supplies energy to the section, which energy it brought from the other sections.

By the power-transfer constant s , sections of low energy dissipation supply power to sections of high energy dissipation.

39. Let for instance in Fig. 43 be represented a circuit consisting of step-up transformer, transmission line, and load. (The load, consisting of step-down transformer and its secondary circuit, may for convenience be considered as one circuit section.) Assume now that the circuit is disconnected from the power supply by low-tension switches, at A . This leaves transformer, line, and load as a compound oscillating circuit, consisting of four sections: the high-tension coil of the step-up transformer, the two lines, and the load.

Let then λ_1 = length of line, λ_2 = length of transformer circuit, and λ_3 = length of load circuit, in velocity measure.* If then

* If l_1 = length of circuit section in any measure, and L_0 = inductance, C_0 = capacity per unit of length l_1 , then the length of the circuit in velocity measure is $\lambda_1 = \sigma_0 l_1$, where $\sigma_0 = \sqrt{L_0 C_0}$.

Thus, if L = inductance, C = capacity per transformer coil, n = number of transformer coils, for the transformer the unit of length is the coil; hence the

Such a flow of power must occur in a circuit containing sections of different dissipation constants u . For instance, if in a circuit consisting of an unloaded transformer and a transmission line, as indicated in Fig. 40, at no load on the step-down trans-

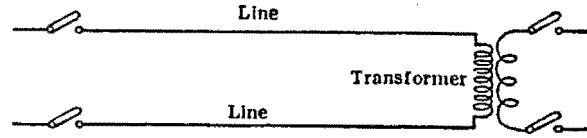

Fig. 40.

former, the high-tension switches are opened at the generator end of the transmission line. The energy stored magnetically and dielectrically in line and transformer then dissipates by a transient, as shown in the oscillogram Fig. 41. This gives the oscillation of a circuit consisting of 28 miles of line and 2500-kw. 100-kv. step-up and step-down transformers, and is produced by disconnecting this circuit by low-tension switches. In the transformer, the duration of the transient would be very great, possibly several seconds, as the stored magnetic energy (L) is very large, the dissipation of power (r and g) relatively small; in the line, the transient is of fairly short duration, as r (and g) are considerable. Left to themselves, the line oscillations thus would die out much more rapidly, by the dissipation of their stored energy, than the transformer oscillations. Since line and transformer are connected together, both must die down simultaneously by the same transient. It then follows that power must flow during the transient from the transformer into the line, so as to have both die down together, in spite of the more rapid energy dissipation in the line. Thus a transient in a *compound circuit*, that is, a circuit comprising sections of different constants, must be a traveling wave, that is, must be accompanied by power transfer between the sections of the circuit.*

A traveling wave, equation (4), would correspond to the case of effective power in a permanent alternating-current circuit, while the stationary wave of the uniform circuit corresponds to the case of reactive power.

Since one of the most important applications of the traveling wave is the investigation of the compound circuit, it is desirable

* In oscillogram Fig. 41, the current wave is shown reversed with regard to the voltage wave for greater clearness.

in the load:

$$p = p_3 e^{-1600\lambda}, \text{ the energy of the wave decreases rapidly.}$$

Here the coefficients of p_1, p_2, p_3 must be such that the wave at the beginning of one section has the same value as at the end of the preceding section.

In general, two traveling waves run around the circuit in opposite direction.

Each of the two waves reaches its maximum intensity in this circuit at the point where it leaves the transformer and enters the line, since in the transformer it increases, while in the line it again decreases, in intensity.

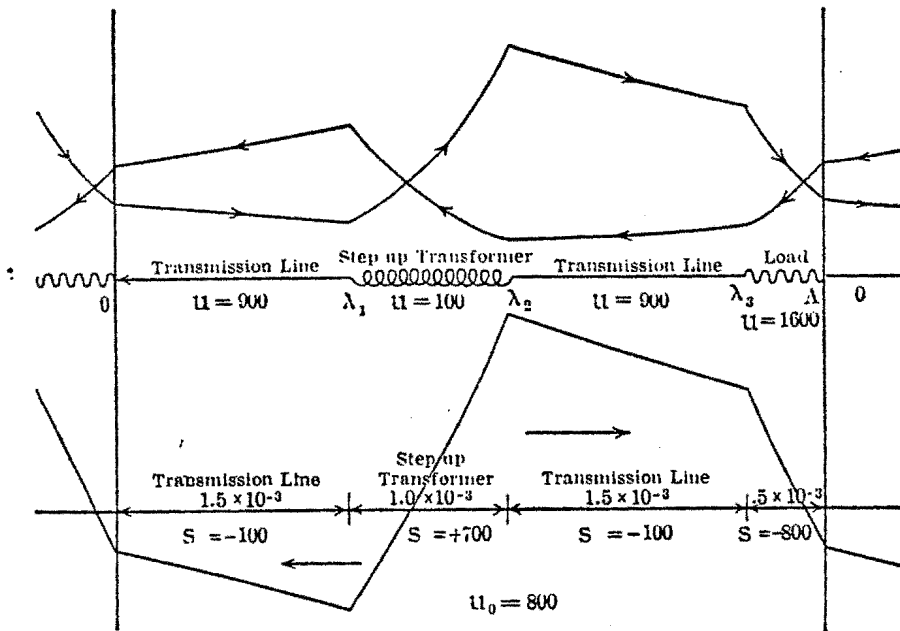

Fig. 54. — Energy Distribution in Compound Oscillation of Closed Circuit; High Line Loss.

Assuming that the maximum value of the one wave is 6, that of the opposite wave 4 megawatts, the power values of the two waves then are plotted in the upper part of Fig. 54, and their difference, that is, the resultant flow of power, in the lower part of Fig. 54. As seen from the latter, there are two power nodes, or points over which no power flows, one in the transformer and one in the load, and the power flows from the transformer over the line into the load; the transformer acts as generator of the power, and of this

to introduce, when dealing with traveling waves, the velocity unit as unit of length, that is, measure the length with the distance of propagation during unit time (3×10^{10} cm. with a straight conductor in air) as unit of length. This allows the use of the same distance unit through all sections of the circuit, and expresses the wave length λ_0 and the period T_0 by the same numerical values, $\lambda_0 = T_0 = \frac{1}{f}$, and makes the time angle ϕ and the distance angle ω directly comparable:

$$\left. \begin{aligned} \phi &= 2\pi ft = 2\pi \frac{t}{\lambda_0}, \\ \omega &= 2\pi \frac{\lambda}{\lambda_0} = 2\pi f\lambda. \end{aligned} \right\} \quad (8)$$

34. If power flows along the circuit, three cases may occur:

(a) The flow of power is uniform, that is, the power remains constant in the direction of propagation, as indicated by A in Fig. 42.

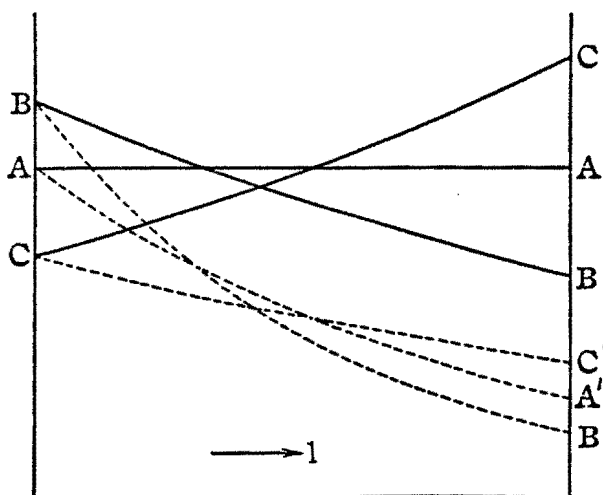

Fig. 42. — Energy Transfer by Traveling Wave.

(b) The flow of power is decreasing in the direction of propagation, as illustrated by B in Fig. 42.

(c) The flow of power is increasing in the direction of propagation, as illustrated by C in Fig. 42.

Obviously, in all three cases the flow of power decreases, due to the energy dissipation by r and g , that is, by the decrement $\epsilon^{-\alpha t}$. Thus, in case (a) the flow of power along the circuit decreases at

That is, the power-transfer constant of the line has become positive, $s_1 = 33$, and the line now assists the transformer in supplying power to the load. Assuming again the values of the two traveling waves, where they leave the transformer (which now are not the maximum values, since the waves still further increase in intensity in passing over the lines), as 6 and 4 megawatts respectively, the power diagram of the two waves, and the power diagram of their resultant, are given in Fig. 55.

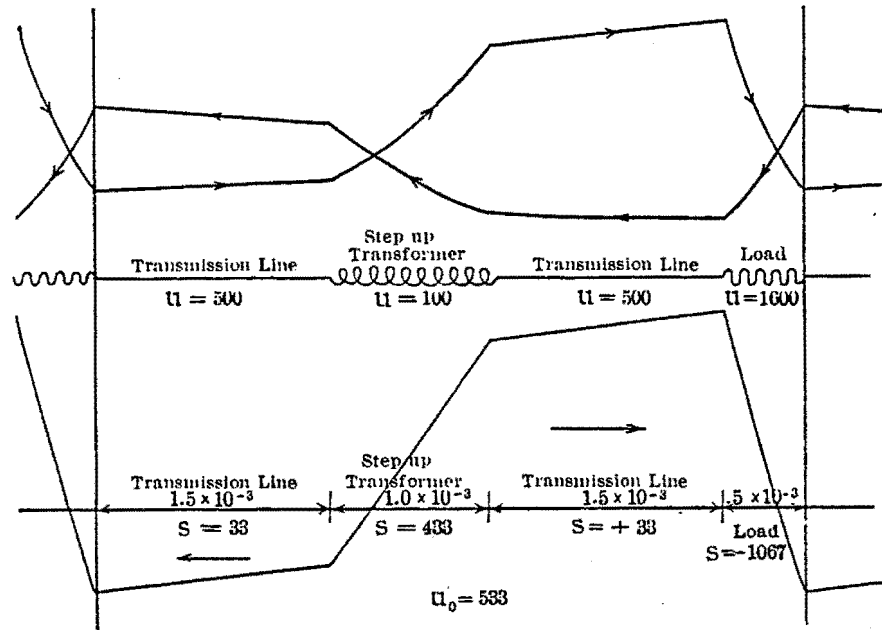

Fig. 55. — Energy Distribution in Compound Oscillation of Closed Circuit; Low Line Loss.

In a closed circuit, as here discussed, the relative intensity of the two component waves of opposite direction is not definite, but depends on the circuit condition at the starting moment of the transient.

In an oscillation of an open compound circuit, the relative intensities of the two component waves are fixed by the condition that at the open ends of the circuit the power transfer must be zero.

As illustration may be considered a circuit comprising the high-potential coil of the step-up transformer, and the two lines, which are assumed as open at the step-down end, as illustrated diagrammatically in Fig. 56.

(b) If the flow of power decreases along the line, every line element receives more power at one end than it gives off at the other end. That is, energy is supplied to the line elements by the flow of power, and the stored energy of the line element thus decreases at a slower rate than corresponds to its power dissipation by r and g . Or, in other words, a part of the power dissipated in the line element is supplied by the flow of power along the line, and only a part supplied by the stored energy.

Since the current and voltage would decrease by the term e^{-ut} , if the line element had only its own stored energy available, when receiving energy from the power flow the decrease of current and voltage would be slower, that is, by a term

$$e^{-(u-s)t}; \quad (10)$$

hence the exponential decrement u is decreased to $(u - s)$, and s then is the exponential coefficient corresponding to the energy supply by the flow of power.

Thus, while u is called the *dissipation constant* of the circuit, s may be called the *power-transfer constant* of the circuit.

Inversely, however, in its propagation along the circuit, λ , such a traveling wave must decrease in intensity more rapidly than corresponds to its power dissipation, by the same factor by which it increased the energy supply of the line elements over which it passed. That is, as function of the distance, the factor $e^{-s\lambda}$ must enter.* In other words, such a traveling wave, in passing along the line, leaves energy behind in the line elements, at the rate e^{+st} , and therefore decreases faster in the direction of progress by $e^{-s\lambda}$. That is, it scatters a part of its energy along its path of travel, and thus dies down more rapidly with the distance of travel.

Thus, in a traveling wave of decreasing power flow, the time decrement is changed to $e^{-(u-s)t}$, and the distance decrement $e^{+s\lambda}$ added, and the equation of a traveling wave of decreasing power flow thus is

$$\left. \begin{aligned} i &= i_0 e^{-(u-s)t} e^{-s\lambda} \cos(\phi - \omega - \gamma) = i_0 e^{-ut} e^{+s(t-\lambda)} \cos(\phi - \omega - \gamma), \\ e &= e_0 e^{-(u-s)t} e^{-s\lambda} \cos(\phi - \omega - \gamma) = e_0 e^{-ut} e^{+s(t-\lambda)} \cos(\phi - \omega - \gamma); \end{aligned} \right\} (11)$$

* Due to the use of the velocity unit of length λ , distance and time are given the same units, $t_0 = \lambda_0$; and the time decrement, e^{+st} , and the distance decrement, $e^{-s\lambda}$, give the same coefficient s in the exponent. Otherwise, the velocity of propagation would enter as factor in the exponent.

as to give the same rate of energy dissipation in all circuit sections. As the result of this power transfer, the stored energy of the system must be uniformly distributed throughout the entire circuit, and if it is not so in the beginning of the transient, local traveling waves redistribute the energy throughout the oscillating circuit, as stated before. Such local oscillations are usually of very high frequency, but sometimes come within the range of the oscillograph, as in Fig. 47.

During the oscillation of the complex circuit, every circuit element $d\lambda$ (in velocity measure), or every wave length or equal part of the wave length, therefore contains the same amount of stored energy. That is, if $e_0 =$ maximum voltage, $i_0 =$ maximum current, and $\lambda_0 =$ wave length, the average energy $\frac{e_0 i_0 \lambda_0}{2}$ must be constant throughout the entire circuit. Since, however, in velocity measure, λ_0 is constant and equal to the period T_0 throughout all the sections of the circuit, the product of maximum voltage and of maximum current, $e_0 i_0$, thus must be constant throughout the entire circuit.

The same applies to an ordinary traveling wave or impulse. Since it is the same energy which moves along the circuit at a constant rate, the energy contents for equal sections of the circuit must be the same except for the factor $e^{-2\alpha t}$, by which the energy decreases with the time, and thus with the distance traversed during this time.

Maximum voltage e_0 and maximum current i_0 , however, are related to each other by the condition

$$\frac{e_0}{i_0} = z_0 = \sqrt{\frac{L_0}{C_0}}, \quad (3)$$

and as the relation of L_0 and C_0 is different in the different sections, and that very much so, z_0 , and with it the ratio of maximum voltage to maximum current, differ for the different sections of the circuit.

If then e_1 and i_1 are maximum voltage and maximum current respectively of one section, and $z_1 = \sqrt{\frac{L_1}{C_1}}$ is the "natural impedance" of this section, and e_2, i_2 , and $z_2 = \sqrt{\frac{L_2}{C_2}}$ are the corresponding values for another section, it is

$$e_2 i_2 = e_1 i_1, \quad (4)$$

that is, the power decreases with the time at a greater, but with the distance at a slower, rate than corresponds to the power dissipation.

For a wave moving in opposite direction, again the sign of λ and thus of ω would be reversed.

35. In the equations (10) to (15), the power-transfer constant s is assumed as positive. In general, it is more convenient to assume that s may be positive or negative; positive for an increasing, negative for a decreasing, flow of power. The equations (13) to (15) then apply also to the case (b) of decreasing power flow, but in the latter case s is negative. They also apply to the case (a) for $s = 0$.

The equation of current, voltage, and power of a traveling wave then can be combined in one expression:

$$\left. \begin{aligned} i &= i_0 e^{-(u+s)t} \epsilon^{\pm s\lambda} \cos(\phi \mp \omega - \gamma) = i_0 e^{-ut} \epsilon^{-s(t \mp \lambda)} \cos(\phi \mp \omega - \gamma), \\ e &= e_0 e^{-(u+s)t} \epsilon^{\pm s\lambda} \cos(\phi \mp \omega - \gamma) = e_0 e^{-ut} \epsilon^{-s(t \mp \lambda)} \cos(\phi \mp \omega - \gamma), \end{aligned} \right\} \quad (16)$$

$$p_0 = \frac{e_0 i_0}{2} \epsilon^{-2(u+s)t} \epsilon^{\pm 2s\lambda} = \frac{e_0 i_0}{2} \epsilon^{-2ut} \epsilon^{-2s(t \mp \lambda)}, \quad (17)$$

where the upper sign applies to a wave traveling in the direction toward rising values of λ , the lower sign to a wave traveling in opposite direction, toward decreasing λ . Usually, waves of both directions of travel exist simultaneously (and in proportions depending on the terminal conditions of the oscillating system, as the values of i and e at its ends, etc.).

$s = 0$ corresponds to a traveling wave of constant power flow (case (a)).

$s > 0$ corresponds to a traveling wave of increasing power flow, that is, a wave which drains the circuit over which it travels of some of its stored energy, and thereby increases the time rate of dying out (case (c)).

$s < 0$ corresponds to a traveling wave of decreasing power flow, that is, a wave which supplies energy to the circuit over which it travels, and thereby decreases the time rate of dying out of the transient.

If s is negative, for a transient wave, it always must be

$$-s \equiv u,$$

since, if $-s > u$, $u + s$ would be negative, and $\epsilon^{-(u+s)t}$ would increase with the time; that is, the intensity of the transient would

42. At the transition point between two successive sections, the current and voltage respectively must be the same in the two sections. Since the maximum values of current and voltage respectively are different in the two sections, the phase angles of the waves of the two sections must be different at the transition point; that is, a change of phase angle occurs at the transition point.

This is illustrated in Fig. 58. Let $z_0 = 200$ in the first section (transmission line), $z_0 = 800$ in the second section (transformer). The transformation ratio between the sections then is $\sqrt{\frac{800}{200}} = 2$; that is, the maximum voltage of the second section is twice, and the maximum current half, that of the first section, and the waves of current and of voltage in the two sections thus may be as illustrated for the voltage in Fig. 58, by $e_1 e_2$.

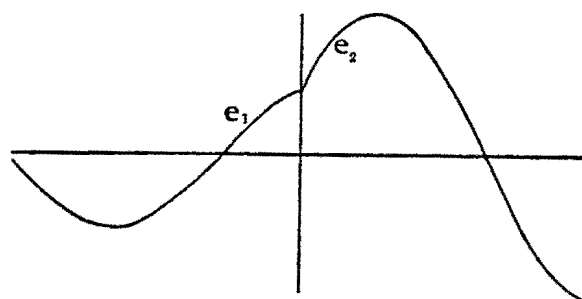

Fig. 58. — Effect of Transition Point on Traveling Wave.

If then e' and i' are the values of voltage and current respectively at the transition point between two sections 1 and 2, and e_1 and i_1 the maximum voltage and maximum current respectively of the first, e_2 and i_2 of the second, section, the voltage phase and current phase at the transition point are, respectively:

$$\left. \begin{array}{l}
 \text{For the wave of the first section:} \\
 \frac{e'}{e_1} = \cos \gamma_1 \quad \text{and} \quad \frac{i'}{i_1} = \cos \delta_1. \\
 \text{For the wave of the second section:} \\
 \frac{e'}{e_2} = \cos \gamma_2 \quad \text{and} \quad \frac{i'}{i_2} = \cos \delta_2.
 \end{array} \right\} \quad (9)$$

circuit and measuring the voltage across the inductance by spark gap. These traveling waves of very high frequency are extremely local, often extending over a few hundred feet only.

An approximate estimate of the effective frequency of these very high frequency local traveling waves can often be made from their striking distance across a small inductance, by means of the relation $\frac{e_0}{i_0} = \sqrt{\frac{L_0}{C_0}} = z_0$, discussed in Lecture VI.

For instance, in the 100,000-volt transmission line of Fig. 48A, the closing of the high-tension oil switch produces a high-frequency oscillation which at a point near its origin, that is, near the switch, jumps a spark gap of 3.3 cm. length, corresponding to $e_1 = 35,000$ volts, across the terminals of a small inductance consisting of 34 turns of 1.3 cm. copper rod, of 15 cm. mean diameter and 80 cm. length. The inductance of this coil is calculated as approximately 13 microhenrys. The line constants, from line to neutral, are $L = 0.323$ henry, $C = 2.2 \times 10^{-6}$ farad; hence $z_0 = \sqrt{\frac{L}{C}} = \sqrt{0.1465} \times 10^3 = 383$ ohms.

The sudden change of voltage at the line terminals, produced by closing the switch, is $\frac{100,000}{\sqrt{3}} = 57,700$ volts effective, or a maximum of $e_0 = 57,700 \times \sqrt{2} = 81,500$ volts, and thus gives a maximum transient current in the impulse, of $i_0 = \frac{e_0}{z_0} = 212$ amperes. $i_0 = 212$ amperes maximum, traversing the inductance of 13 microhenrys, thus give the voltage, recorded by the spark gap, of $e_1 = 35,000$. If then $f =$ frequency of impulse, it is

$$e_1 = 2\pi f L i_0.$$

$$\begin{aligned} \text{Or,} \quad f &= \frac{e_1}{2\pi L i_0}, \\ &= \frac{35,000}{2\pi \times 13 \times 10^{-6} \times 212} \\ &= 2,000,000 \text{ cycles.} \end{aligned}$$

37. A common form of traveling wave is the discharge of a local accumulation of stored energy, as produced for instance by a direct or induced lightning stroke, or by the local disturbance caused by a change of circuit conditions, as by switching, the blowing of fuses, etc.

that is, are not transient, but permanent or alternating currents and voltages.

Writing the two waves in (18) separately gives

$$\left. \begin{aligned} i &= i_0 \epsilon^{+s\lambda} \cos(\phi - \omega - \gamma_1) - i_0' \epsilon^{-s\lambda} (\phi + \omega - \gamma_2), \\ e &= e_0 \epsilon^{+s\lambda} \cos(\phi - \omega - \gamma_1) + e_0' \epsilon^{-s\lambda} (\phi + \omega - \gamma_2), \end{aligned} \right\} \quad (19)$$

and these are the equations of the alternating-current transmission line, and reduce, by the substitution of the complex quantity for the function of the time angle ϕ , to the standard form given in "Transient Phenomena," Section III.

36. Obviously, traveling waves and standing waves may occur simultaneously in the same circuit, and usually do so, just as in alternating-current circuits effective and reactive waves occur simultaneously. In an alternating-current circuit, that is, in permanent condition, the wave of effective power (current in phase with the voltage) and the wave of reactive power (current in quadrature with the voltage) are combined into a single wave, in which the current is displaced from the voltage by more than 0 but less than 90 degrees. This cannot be done with transient waves. The transient wave of effective power, that is, the traveling wave,

$$\left. \begin{aligned} i &= i_0 \epsilon^{-ut} \epsilon^{-s(t \pm \lambda)} \cos(\phi \mp \omega - \gamma), \\ e &= e_0 \epsilon^{-ut} \epsilon^{-s(t \pm \lambda)} \cos(\phi \mp \omega - \gamma), \end{aligned} \right.$$

cannot be combined with the transient wave of reactive power, that is, the stationary wave,

$$\left. \begin{aligned} i &= i_0' \epsilon^{-ut} \cos(\phi \mp \omega - \gamma'), \\ e &= e_0' \epsilon^{-ut} \sin(\phi \mp \omega - \gamma'), \end{aligned} \right.$$

to form a transient wave, in which current and voltage differ in phase by more than 0 but less than 90 degrees, since the traveling wave contains the factor $\epsilon^{-s(t \mp \lambda)}$, resulting from its progression along the circuit, while the stationary wave does not contain this factor, as it does not progress.

This makes the theory of transient waves more complex than that of alternating waves.

Thus traveling waves and standing waves can be combined only locally, that is, the resultant gives a wave in which the phase angle between current and voltage changes with the distance λ and with the time t .

LECTURE X.

CONTINUAL AND CUMULATIVE OSCILLATIONS.

43. A transient is the phenomenon by which the stored energy readjusts itself to a change of circuit conditions. In an oscillatory transient, the difference of stored energy of the previous and the after condition of the circuit, at a circuit change, oscillates between magnetic and dielectric energy. As there always must be some energy dissipation in the circuit, the oscillating energy of the transient must steadily decline, that is, the transient must die out, at a rate depending on the energy dissipation in the circuit.

Thus, the oscillation resulting from a change of circuit conditions can become continual, that is, of constant amplitude, or cumulative, that is, of increasing amplitude, only if a steady supply of oscillating energy occurs.

Continual and cumulative oscillations thus involve a continual energy supply to the oscillating system, therefore cannot be mere readjustments of circuit conditions by the dissipation of stored energy.

If the continual energy supply is less than the energy dissipation in the circuit, the oscillation dies out, that is, is transient, but with a lowered attenuation constant. This for instance is the case with the transient in those sections of a compound circuit, in which the energy transfer constant is negative. If the continual energy supply equals the energy dissipation, the oscillation is continual, and if the energy supply is greater than the energy dissipation, the oscillation becomes cumulative, that is, increasing in amplitude, until either the system breaks down or, by the increase of the energy dissipation, it becomes equal to the energy supply, and the oscillation becomes continual.

A continual or cumulative oscillation thus involves an energy and frequency transformation, from the low-frequency or continuous-current energy of the power supply of the system to the high-frequency energy of the oscillation.

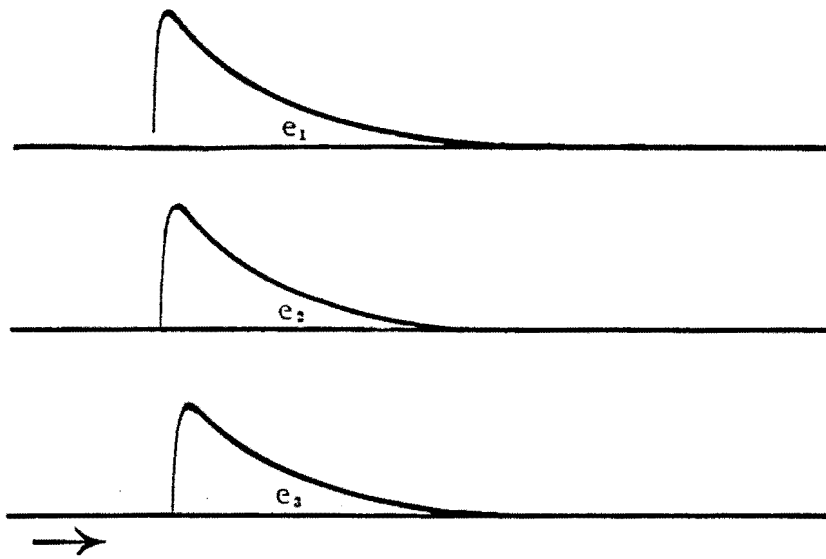

Fig. 51. — cd11145. — Reproduction of Oscillogram of Propagation of Impulse Over Transmission Line; no Reflection. Voltage.

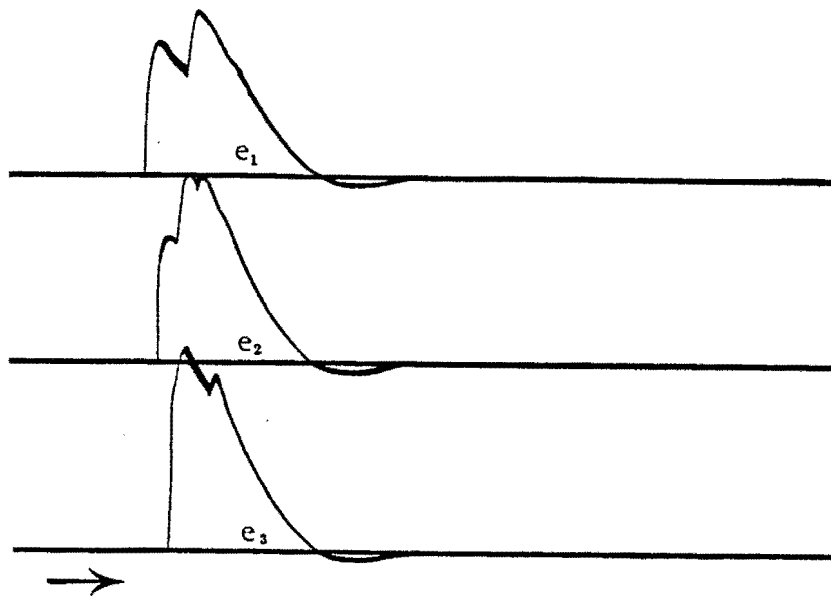

Fig. 52. — cd11152. — Reproduction of Oscillogram of Propagation of Impulse Over Transmission Line; Reflection from Open End of Line. Voltage.

LECTURE IX.

OSCILLATIONS OF THE COMPOUND CIRCUIT.

38. The most interesting and most important application of the traveling wave is that of the stationary oscillation of a compound circuit, as industrial circuits are never uniform, but consist of sections of different characteristics, as the generating system, transformer, line, load, etc. Oscillograms of such circuits have been shown in the previous lecture.

If we have a circuit consisting of sections 1, 2, 3 . . . , of the respective lengths (in velocity measure) $\lambda_1, \lambda_2, \lambda_3 . . .$, this entire circuit, when left to itself, gradually dissipates its stored energy by a transient. As function of the time, this transient must decrease at the same rate u_0 throughout the entire circuit. Thus the time decrement of all the sections must be

$$\epsilon^{-u_0 t}.$$

Every section, however, has a power-dissipation constant, $u_1, u_2, u_3 . . .$, which represents the rate at which the stored energy of the section would be dissipated by the losses of power in the section,

$$\epsilon^{-u_1 t}, \epsilon^{-u_2 t}, \epsilon^{-u_3 t} . . .$$

But since as part of the whole circuit each section must die down at the same rate $\epsilon^{-u_0 t}$, in addition to its power-dissipation decrement $\epsilon^{-u_1 t}, \epsilon^{-u_2 t} . . .$, each section must still have a second time decrement, $\epsilon^{-(u_0 - u_1)t}, \epsilon^{-(u_0 - u_2)t} . . .$. This latter does not represent power dissipation, and thus represents power transfer. That is,

$$\begin{aligned} s_1 &= u_0 - u_1, \\ s_2 &= u_0 - u_2, \\ &\cdot \\ &\cdot \\ &\cdot \end{aligned} \tag{1}$$

It thus follows that in a compound circuit, if u_0 is the average exponential time decrement of the complete circuit, or the average

power a fraction is consumed in the line, the rest supplied to the load.

40. The diagram of this transient power transfer of the system thus is very similar to that of the permanent power transmission by alternating currents: a source of power, a partial consumption in the line, and the rest of the power consumed in the load.

However, this transient power-transfer diagram does not represent the entire power which is being consumed in the circuit, as power is also supplied from the stored energy of the circuit; and the case may thus arise — which cannot exist in a permanent power transmission — that the power dissipation of the line is less than corresponds to its stored energy, and the line also supplies power to the load, that is, acts as generator, and in this case the power would not be a maximum at the transformer terminals, but would still further increase in the line, reaching its maximum at the load terminals. This obviously is possible only with transient power, where the line has a store of energy from which it can draw in supplying power. In permanent condition the line could not add to the power, but must consume, that is, the permanent power-transmission diagram must always be like Fig. 54.

Not so, as seen, with the transient of the stationary oscillation. Assume, for instance, that we reduce the power dissipation in the line by doubling the conductor section, that is, reducing the resistance to one-half. As L thereby also slightly decreases, C increases, and g possibly changes, the change brought about in the constant $u = \frac{1}{2} \left(\frac{r}{L} + \frac{g}{C} \right)$ is not necessarily a reduction to one-half, but depends upon the dimensions of the line. Assuming therefore, that the power-dissipation constant of the line is by the doubling of the line section reduced from $u_1 = 900$ to $u_1 = 500$, this gives the constants:

	Line.	Transformer.	Line.	Load.	Sum.
$\lambda =$	1.5×10^{-3}	1×10^{-3}	1.5×10^{-3}	$.5 \times 10^{-3}$	4.5×10^{-3}
$u =$	500	100	500	1600	
$u\lambda =$.75	.1	.75	.8	2.4

hence, $u_0 = \text{average } u = \frac{\sum u\lambda}{\sum \lambda} = 533$, and:

$$s = \quad +33 \quad +433 \quad +33 \quad -1067$$

Choosing the same lengths and the same power-dissipation constants as in the previous illustrations, this gives:

	Line.	Transformer.	Line.	Sum.
$\lambda =$	1.5×10^{-3}	1×10^{-3}	1.5×10^{-3}	4×10^{-3}
$u =$	900	100	900	
$u\lambda =$	1.35	.1	1.35	2.8

hence, $u_0 = \text{average } u = \frac{\sum u\lambda}{\sum \lambda} = 700$, and:

$$s = \quad -200 \quad +600 \quad -200$$

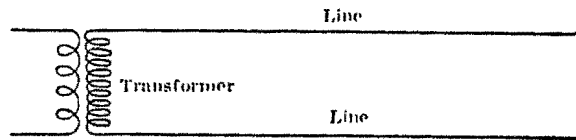

Fig. 56.

The diagram of the power of the two waves of opposite directions, and of the resultant power, is shown in Fig. 57, assuming 6 megawatts as the maximum power of each wave, which is reached at the point where it leaves the transformer.

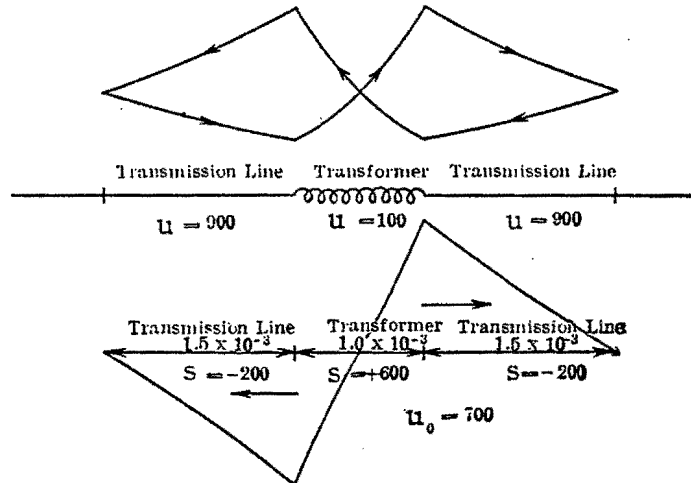

Fig. 57. — Energy Distribution in Compound Oscillation of Open Circuit.

In this case the two waves must be of the same intensity, so as to give 0 as resultant at the open ends of the line. A power node then appears in the center of the transformer.

41. A stationary oscillation of a compound circuit consists of two traveling waves, traversing the circuit in opposite direction, and transferring power between the circuit sections in such a manner

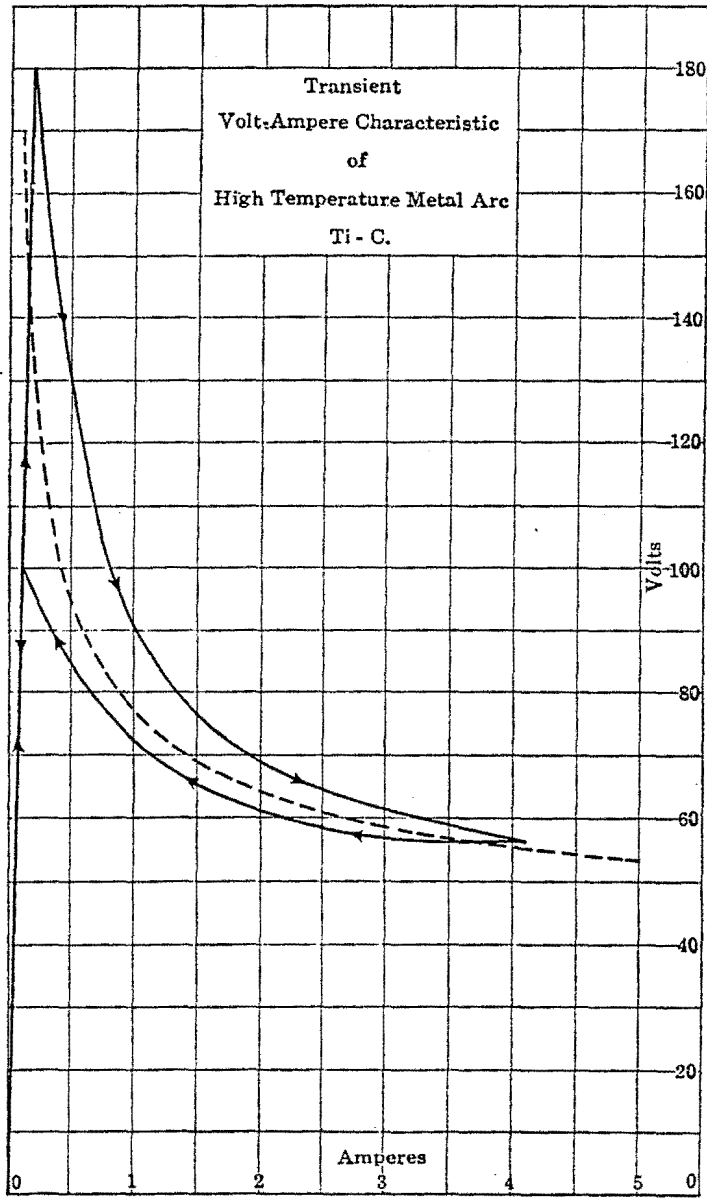

Fig. 66.

and since

$$\frac{e_2}{i_2} = z_2; \quad \frac{e_1}{i_1} = z_1, \quad (5)$$

substituting

$$\left. \begin{aligned} e_2 &= i_2 z_2, \\ e_1 &= i_1 z_1, \end{aligned} \right\} \quad (6)$$

into (4) gives

$$i_2^2 z_2 = i_1^2 z_1,$$

or

$$\frac{i_2}{i_1} = \sqrt{\frac{z_1}{z_2}} = \sqrt[4]{\frac{L_1 C_2}{C_1 L_2}}, \quad (7)$$

and

$$\frac{e_2^2}{z_2} = \frac{e_1^2}{z_1},$$

or

$$\frac{e_2}{e_1} = \sqrt{\frac{z_2}{z_1}} = \sqrt[4]{\frac{L_2 C_1}{C_2 L_1}}. \quad (8)$$

That is, in the same oscillating circuit, the maximum voltages e_0 in the different sections are proportional to, and the maximum currents i_0 inversely proportional to, the square root of the natural impedances z_0 of the sections, that is, to the fourth root of the ratios of inductance to capacity $\frac{L_0}{C_0}$.

At every transition point between successive sections traversed by a traveling wave, as those of an oscillating system, a transformation of voltage and of current occurs, by a transformation ratio which is the square root of the ratio of the natural impedances, $z_0 = \sqrt{\frac{L_0}{C_0}}$, of the two respective sections.

When passing from a section of high capacity and low inductance, that is, low impedance z_0 , to a section of low capacity and high inductance, that is, high impedance z_0 , as when passing from a transmission line into a transformer, or from a cable into a transmission line, the voltage thus is transformed up, and the current transformed down, and inversely, with a wave passing in opposite direction.

A low-voltage high-current wave in a transmission line thus becomes a high-voltage low-current wave in a transformer, and inversely, and thus, while it may be harmless in the line, may become destructive in the transformer, etc.

Dividing the two pairs of equations of (9) gives

$$\left. \begin{aligned} \frac{\cos \gamma_2}{\cos \gamma_1} = \frac{e_1}{e_2} = \sqrt{\frac{z_1}{z_2}}, \\ \frac{\cos \delta_2}{\cos \delta_1} = \frac{i_1}{i_2} = \sqrt{\frac{z_2}{z_1}}, \end{aligned} \right\} \quad (10)$$

hence, multiplied,

$$\left. \begin{aligned} \frac{\cos \gamma_2}{\cos \gamma_1} \times \frac{\cos \delta_2}{\cos \delta_1} = 1, \\ \frac{\cos \gamma_2}{\cos \gamma_1} = \frac{\cos \delta_1}{\cos \delta_2}, \end{aligned} \right\} \quad (11)$$

or

$$\cos \gamma_1 \cos \delta_1 = \cos \gamma_2 \cos \delta_2;$$

that is, the ratio of the cosines of the current phases at the transition point is the reciprocal of the ratio of the cosines of the voltage phases at this point.

Since at the transition point between two sections the voltage and current change, from e_1, i_1 to e_2, i_2 , by the transformation ratio

$\sqrt{\frac{z_2}{z_1}}$, this change can also be represented as a partial reflection.

That is, the current i_1 can be considered as consisting of a component i_2 , which passes over the transition point, is "transmitted" current, and a component $i_1' = i_1 - i_2$, which is "reflected" current, etc. The greater then the change of circuit constants at the transition point, the greater is the difference between the currents and voltages of the two sections; that is, the more of current and voltage are reflected, the less transmitted, and if the change of constants is very great, as when entering from a transmission line a reactance of very low capacity, almost all the current is reflected, and very little passes into and through the reactance, but a high voltage is produced in the reactance.

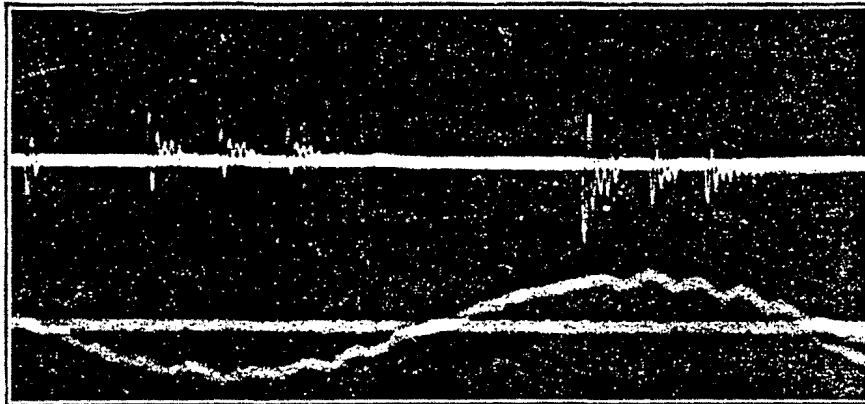

Fig. 59. — Recurrent Oscillation of Arcing Ground, in 10 Miles of 22,000-volt Three-phase 40-cycle Transmission Line.

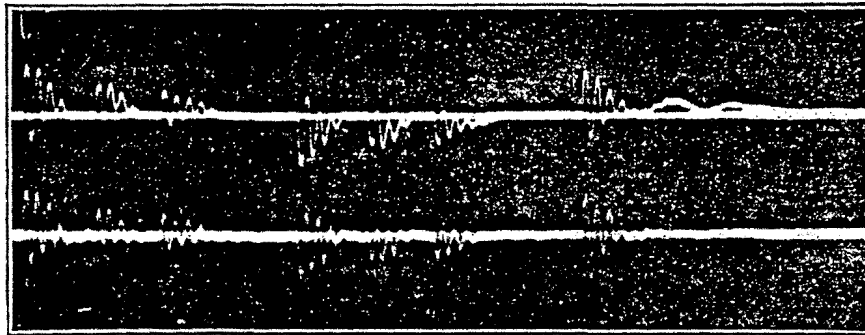

Fig. 60. — Recurrent Oscillation of Arcing Ground, in 21.5 Miles of 22,000-volt Three-phase 40-cycle Transmission Line.

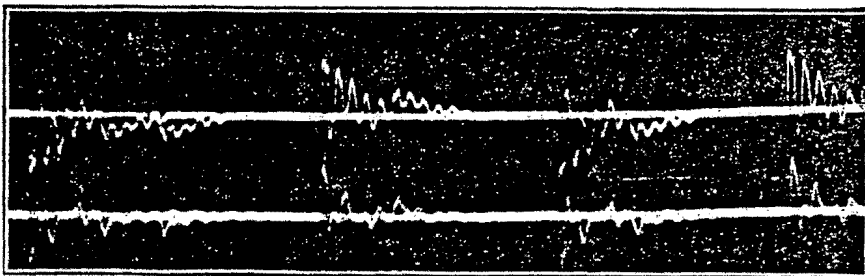

Fig. 61. — Change from Recurrent to Continuous Oscillation of Arcing Ground, in 32 Miles of 22,000-volt Three-phase 40-cycle Transmission Line.

grams, Figs. 62 to 65, were taken on an artificial transmission line.* Oscillations of the type 64 and 65 are industrially used, as "singing arc," in wireless telegraphy, and are produced by shunting a suitable arc by a circuit containing capacity and inductance in series with each other.

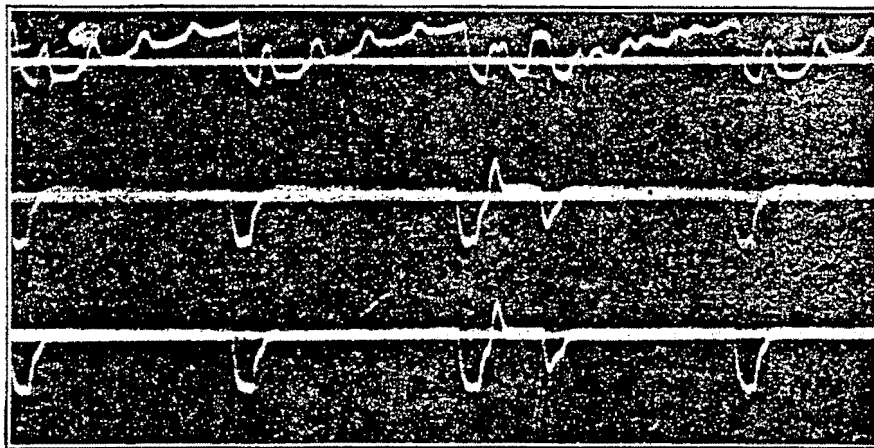

Fig. 62. — Semi-continuous Recurrent Oscillation of Arcing Ground in Transmission Line.

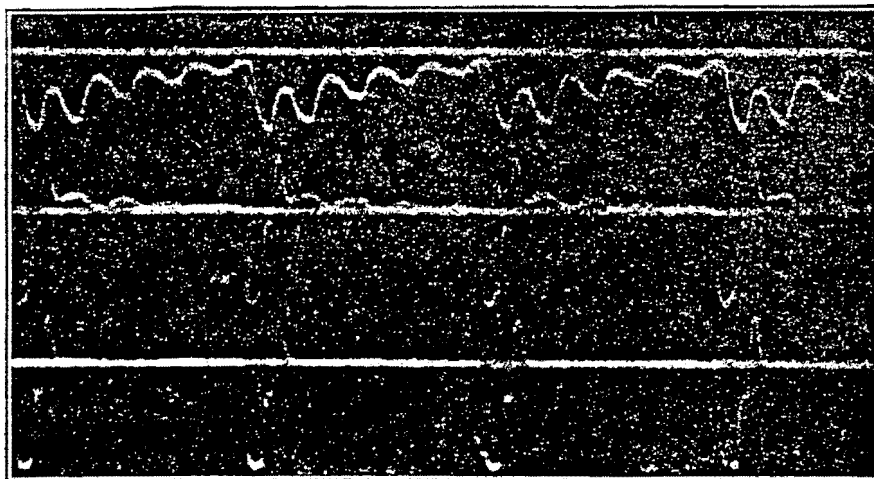

Fig. 63. — Semi-continuous Recurrent Oscillation of Arcing Ground in Transmission Line.

* "Design, Construction and Test of an Artificial Transmission Line," J. H. Cunningham, A. I. E. E. Transact., 1911.

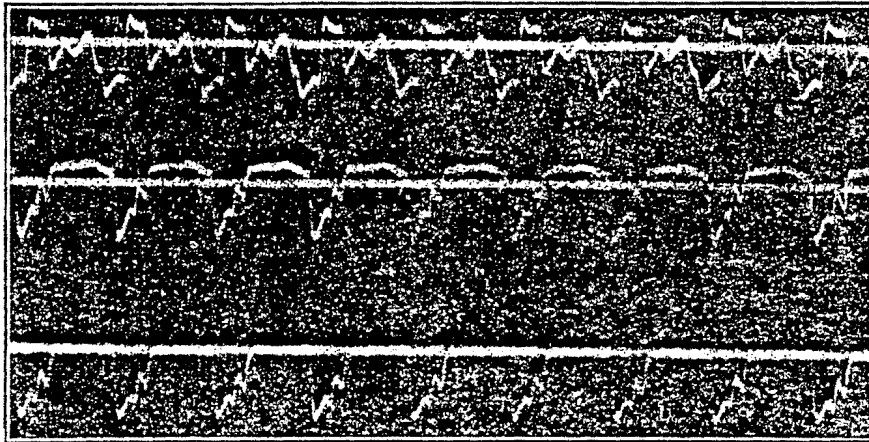

Fig. 64. — Continuous Oscillation of Arcing Ground in Transmission Line.

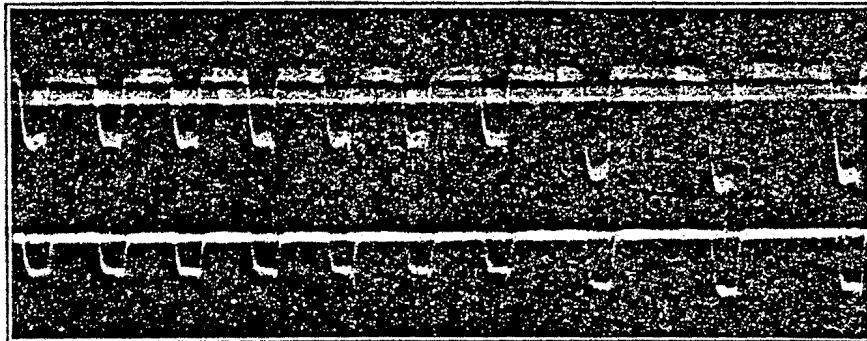

Fig. 65. — Continuous Oscillation of Arcing Ground in Transmission Line.

44. However, the formation of continuous oscillations, Figs. 61 to 65, from the recurrent oscillations, Figs. 59 and 60, is not a mere running together and overlapping of successive wave trains. In Fig. 59, the succeeding oscillation cannot start, until the preceding oscillation has died out and a sufficient time elapsed, for the line to charge again to a voltage which is high enough to discharge to ground and so start the next oscillation, that is, to store the energy for the next oscillation. If then, with an overlap of successive oscillations, no dead period occurs, during which the energy, which oscillates during the next wave train, is supplied to the line, this energy must be supplied during the oscillation, that is, there must be such a phase displacement or lag within the oscillation, which gives a negative energy cycle, or reversed hysteresis loop. Thus, essential for such a continual oscillation is the

turbance in the system, as lightning, change of load, etc., is only the exciting cause which starts the energy transformation to the oscillating frequency by the arc, etc., and the frequency with which the oscillation occurs then is determined by the circuit constants. Or, as is often stated: the electric arc has no frequency of its own, but oscillates with whatever frequency the circuit is able to oscillate. Thus such oscillations are not uncommon, and have in the last years been observed, measured and recorded in numerous instances, and experimentally produced in lines and high-potential transformer windings. The continual oscillations in transmission lines usually seem to be recurrent oscillations, as in Figs. 59 and 60, while in high-potential transformer windings, due to their much lesser damping, continuous oscillations seem to be more common, as in Fig. 46. Our knowledge of these phenomena is however still extremely incomplete.

lines of force is still more complicated, and varies during the cyclic change of current.

The calculation of such more complex magnetic and dielectric fields becomes simple, however, by the method of *superposition of fields*. As long as the magnetic and the dielectric flux are proportional respectively to the current and the voltage, — which is the case with the former in nonmagnetic materials, with the latter for all densities below the dielectric strength of the material, — the resultant field of any number of conductors at any point in space is the combination of the component fields of the individual conductors.

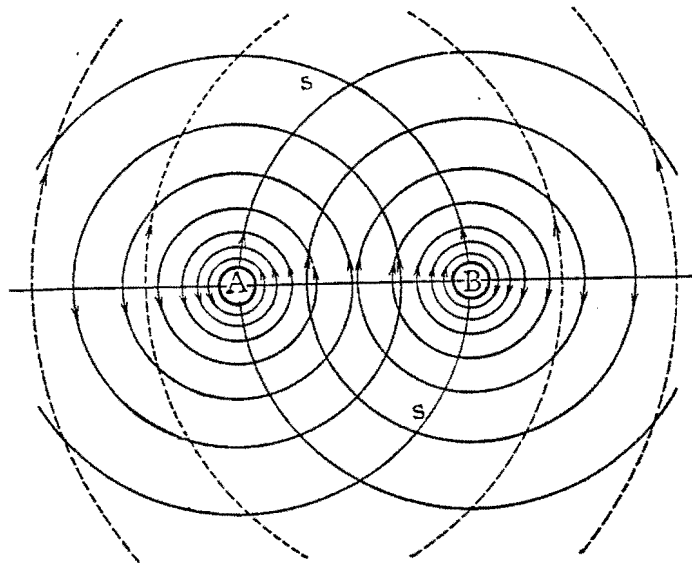

Fig. 67. — Magnetic Field of Circuit.

Thus the field of conductor *A* and return conductor *B* is the combination of the field of *A*, of the shape Fig. 8, and the field of *B*, of the same shape, but in opposite direction, as shown for the magnetic fields in Fig. 67.

All the lines of magnetic force of the resultant magnetic field must pass between the two conductors, since a line of magnetic force, which surrounds both conductors, would have no m.m.f., and thus could not exist. That is, the lines of magnetic force of *A* beyond *B*, and those of *B* beyond *A*, shown dotted in Fig. 67, neutralize each other and thereby vanish; thus, in determining the resultant magnetic flux of conductor and return conductor (whether the latter is a single conductor, or divided into two con-

existence of a hysteresis loop, formed by the lag of the effect behind the cause. Such a hysteresis loop exists in the transient arc, as illustrated by Fig. 66: the transient volt-ampere characteristic of a short high-temperature metal arc, between titanium and carbon. In this figure, the stationary arc characteristic, that is, the relation between arc voltage and arc current in stationary conditions, is shown in dotted lines, and the drawn line shows the cycle existing between arc current and arc voltage during a cyclic change of current, from zero to 4.1 amperes and back to zero, within $\frac{1}{100}$ of a second, with the current varying approximately as a sine function of the time. As seen, for rising current, the arc voltage is materially higher than for decreasing current. Close to zero current, the arc has ceased, and Geissler tube conduction passes the current through the residual vapor stream.

Other hysteresis cycles than those of the arc are instrumental in the energy supply to other systems of continual oscillation. Thus, for instance, the hysteresis cycle between synchronizing force and position displacement supplies the energy of the continual or cumulative oscillation, called hunting, in synchronous machines, as alternators, synchronous motors and converters. The mechanism, by which the hysteresis cycle supplies the energy of continual oscillations, has been investigated in the case of the hunting of synchronous machines,* but is still practically unknown in the case of continual oscillations between magnetic and dielectric energy in electric circuits.

Recurrent oscillations, as in Fig. 59, must be or very soon become continual, that is, the successive wave trains are of approximately constant amplitude, since each starts with the same energy, the stored energy of the supply system. Continual oscillations, however, in which the energy supply is through a hysteresis cycle, may be cumulative: the area of the hysteresis cycle, that is, the energy supply, depends on and increases with the voltage and current of the oscillation, and the voltage and current, that is, the intensity of the oscillation, depends on and increases with the energy supply, that is, the area of the hysteresis cycle, thus both increase together.

Such cumulative oscillations are represented for instance by Fig. 46, page 99.

* "Instability of Electric Circuits," A. I. E. E. Proceedings, Jan., 1914.

and the magnetic flux in the zone dx thus is

$$d\Phi = \frac{2 \mu F}{x} dx, \quad (6)$$

and the magnetic flux interlinked with the conductor thus is

$$nd\Phi = \frac{2 \mu nF}{x} dx, \quad (7)$$

hence the total magnetic flux between the distances x_1 and x_2 is

$$n\Phi|_1^2 = \int_{x_1}^{x_2} \frac{2 \mu nF}{x} dx;$$

thus the inductance

$$L|_1^2 = \frac{n\Phi|_1^2}{i} = \int_{x_1}^{x_2} 2 \mu \frac{nF}{i} \frac{dx}{x}. \quad (8)$$

1. External magnetic flux. $x_1 = r$; $x_2 = s$; $F = i$, as this flux surrounds the total current; and $n = 1$, as each line of magnetic force surrounds the conductor once. $\mu = 1$ in air, thus:

$$L_1 = \int_r^s \frac{2 dx}{x} = 2 \log \frac{s}{r}. \quad (9)$$

2. Internal magnetic flux. Assuming uniform current density throughout the conductor section, it is

$$x_1 = 0; \quad x_2 = r; \quad \frac{F}{i} = \left(\frac{x}{r}\right)^2,$$

as the flux is produced by a part of the current only; and $n = \left(\frac{x}{r}\right)^2$, as each line of magnetic force surrounds only a part of the conductor

$$L_2 = \int_0^r \frac{2 \mu x^3 dx}{r^4} = \frac{\mu}{2}, \quad (10)$$

and the total inductance of the conductor thus is

$$L = L_1 + L_2 = 2 \left\{ \log \frac{s}{r} + \frac{\mu}{4} \right\} \text{ per cm. length of conductor,} \quad (11)$$

or, if the conductor consists of nonmagnetic material, $\mu = 1$:

$$L = 2 \left\{ \log \frac{s}{r} + \frac{1}{4} \right\}. \quad (12)$$

it is

$$\log \frac{s+r}{s-r} = \log \frac{s+r}{s} - \log \frac{s-r}{s} = \log \left(1 + \frac{r}{s}\right) - \log \left(1 - \frac{r}{s}\right) = 2 \frac{r}{s},$$

hence

$$L_3 = \frac{s+r}{r} \times \frac{2r}{s} - 2 = \frac{2r}{s}. \quad (19)$$

(b) For $s-r < x < s$, it is

$$\frac{F}{i} = 1 - \frac{1}{2} \left(\frac{x-s+r}{r} \right)^2, \quad (20)$$

and for $s < x < s+r$, it is

$$\frac{F}{i} = \frac{1}{2} \left(\frac{s+r-x}{r} \right)^2, \quad (21)$$

hence,

$$L_3 = \int_{s-r}^s \left[2 - \left(\frac{x-s+r}{r} \right)^2 \right] \frac{dx}{x} + \int_s^{s+r} \left(\frac{s+r-x}{r} \right)^2 \frac{dx}{x}, \quad (22)$$

and integrated this gives

$$L_3 = 2 \log \frac{s}{s-r} + \frac{(s+r)^2}{r^2} \log \frac{s+r}{s} - \frac{(s-r)^2}{r^2} \log \frac{s}{s-r} - 3, \quad (23)$$

and by the approximation (18) this reduces to

$$L_3 = \frac{2r}{s}, \quad (24)$$

that is, the same value as (19); and as the actual case, Fig. 69, should lie between Figs. 70 and 71, the common approximation of the latter two cases should be a close approximation of case 4.

That is, for conductors close together it is

$$\begin{aligned} L &= L_1 + L_2 + L_3 \\ &= 2 \left\{ \log \frac{s-r}{r} + \frac{\mu}{4} + \frac{r}{s} \right\} 10^{-9} h. \end{aligned} \quad (25)$$

However, $\frac{r}{s}$ can be considered as the approximation of $-\log$

$\left(1 - \frac{r}{s}\right) = \log \frac{s}{s-r}$, and substituting this in (25) gives, by combining

$$\log \frac{s-r}{r} + \log \frac{s}{s-r} = \log \frac{s}{r}:$$

$$L = 2 \left\{ \log \frac{s}{r} + \frac{\mu}{4} \right\} 10^{-9} h, \quad (26)$$

The flux then consists of three parts:

Φ_1 , between the conductors, giving the inductance

$$L_1 = 2 \log \frac{s-r}{r},$$

and shown shaded in Fig. 69.

Φ_2 , inside of conductor A , giving the inductance

$$L_2 = \frac{\mu}{2}.$$

Φ_3 , the flux external to A , which passes through conductor B and thereby incloses the conductor A and part of the conductor B , and thus has a m.m.f. less than i , that is, gives $\frac{F}{i} < 1$.

That is, a line of magnetic force at distance $s-r < x < s+r$ incloses the part q of the conductor B , thus incloses the fraction $\frac{q}{r^2\pi}$ of the return current, and thus has the m.m.f.

$$\frac{F}{i} = 1 - \frac{q}{r^2\pi}.$$

An exact calculation of the flux Φ_3 , and the component inductance L_3 resulting from it, is complicated, and, due to the nature of the phenomenon, the result could not be accurate; and an approximation is sufficient in giving an accuracy as great as the variability of the phenomenon permits.

The magnetic flux Φ_3 does not merely give an inductance, but, if alternating, produces a potential difference between the two sides of conductor B , and thereby a higher current density on the side of B toward A ; and as this effect depends on the conductivity of the conductor material, and on the frequency of the current, it cannot be determined without having the frequency, etc., given. The same applies for the flux Φ_1 , which is reduced by unequal current density due to its screening effect, so that in the limiting case, for conductors of perfect conductivity, that is, zero resistance, or for infinite, that is, very high frequency, only the magnetic flux Φ_1 exists, which is shown shaded in Fig. 5; but Φ_2 and Φ_3 are zero, and the inductance is

$$L = 2 \log \frac{s-r}{r} 10^{-9} h. \quad (15)$$

LECTURE XI.

INDUCTANCE AND CAPACITY OF ROUND PARALLEL CONDUCTORS.

A. Inductance and capacity.

46. As inductance and capacity are the two circuit constants which represent the energy storage, and which therefore are of fundamental importance in the study of transients, their calculation is discussed in the following.

The inductance is the ratio of the interlinkages of the magnetic flux to the current,

$$L = \frac{n\Phi}{i}, \quad (1)$$

where Φ = magnetic flux or number of lines of magnetic force, and n the number of times which each line of magnetic force interlinks with the current i .

The capacity is the ratio of the dielectric flux to the voltage,

$$C = \frac{\Psi}{e}, \quad (2)$$

where Ψ is the dielectric flux, or number of lines of dielectric force, and e the voltage which produces it.

With a single round conductor without return conductor (as wireless antennæ) or with the return conductor at infinite distance, the lines of magnetic force are concentric circles, shown by drawn lines in Fig. 8, page 10, and the lines of dielectric force are straight lines radiating from the conductor, shown dotted in Fig. 8.

Due to the return conductor, in a two-wire circuit, the lines of magnetic and dielectric force are crowded together between the conductors, and the former become eccentric circles, the latter circles intersecting in two points (the foci) inside of the conductors, as shown in Fig. 9, page 11. With more than one return conductor, and with phase displacement between the return currents, as in a three-phase three-wire circuit, the path of the

This is in absolute units, and, reduced to henrys, = 10^9 absolute units:

$$L = 2 \left\{ \log \frac{s}{r} + \frac{\mu}{4} \right\} 10^{-9} h \text{ per cm.} \quad (13)$$

$$= 2 \left\{ \log \frac{s}{r} + \frac{1}{4} \right\} 10^{-9} h \text{ per cm.} \quad (14)$$

In these equations the logarithm is the natural logarithm, which is most conveniently derived by dividing the common or 10 logarithm by 0.4343.*

C. Discussion of inductance.

48. In equations (11) to (14) s is the distance between the conductors. If s is large compared with r , it is immaterial whether s is considered the distance between the conductor centers, or between the insides, or outsides, etc.; and, in calculating the inductance of transmission-line conductors, this is the case, and it therefore is immaterial which distance is chosen as s ; and usually, in speaking of the "distance between the line conductors," no attention is paid to the meaning of s .

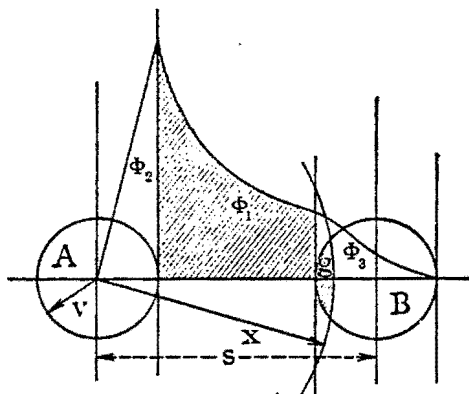

Fig. 69. — Inductance Calculation of Cable.

However, if s is of the same magnitude as r , as with the conductors of cables, the meaning of s has to be specified.

Let then in Fig. 69 r = radius of conductors, and s = distance between conductor centers. Assuming uniform current density in the conductors, the flux distribution of conductor A then is as indicated diagrammatically in Fig. 69.

* $0.4343 = \log_{10} e$.

and
$$K = \frac{G}{4\pi v^2} = \frac{e}{4\pi v^2 l} = \text{dielectric field intensity,} \quad (28)$$

where v^2 is the reduction factor from the electrostatic to the electromagnetic system of units, and

$$v = 3 \times 10^{10} \text{ cm. sec.} = \text{velocity of light;} \quad (29)$$

the dielectric density then is

$$D = \kappa K = \frac{\kappa e}{4\pi v^2 l}, \quad (30)$$

where κ = specific capacity of medium, = 1 in air. The dielectric flux then is

$$\Psi = AD = \frac{\kappa e A}{4\pi v^2 l}, \quad (31)$$

where A = section of dielectric flux. Or inversely:

$$e = \frac{4\pi v^2 l}{\kappa A} \Psi. \quad (32)$$

If then Ψ = dielectric flux, in Fig. 68, at a distance x from the conductor A , in a zone of thickness dx , and section $2\pi x$, the voltage is, by (32),

$$\begin{aligned} de &= \frac{4\pi v^2 dx}{2\pi x \kappa} \Psi \\ &= \frac{2v^2 \Psi dx}{\kappa x}, \end{aligned} \quad (33)$$

and the voltage consumed between distances x_1 and x_2 thus is

$$e] = \int_{x_1}^{x_2} de = \frac{2v^2 \Psi}{\kappa} \log \frac{x_2}{x_1}, \quad (34)$$

hence the capacity of this space:

$$C]_1^2 = \frac{\Psi}{e]_1^2} = \frac{\kappa}{2v^2 \log \frac{x_2}{x_1}}. \quad (35)$$

The capacity of the conductor A with the return conductor at distance s then is the capacity of the space from the distance $x_1 = r$ to the distance $x_2 = s$, hence is, by (35),

$$C = \frac{\kappa}{2v^2 \log \frac{s}{r}} \text{ per cm.} \quad (36)$$

That is, in other words, with small conductors and moderate currents, the total inductance in Fig. 69 is so small compared with the inductances in the other parts of the electric circuit that no very great accuracy of its calculation is required; with large conductors and large currents, however, the unequal current distribution and resultant increase of resistance become so considerable, with round conductors, as to make their use uneconomical, and leads to the use of flat conductors. With flat conductors, however, conductivity and frequency enter into the value of inductance as determining factors.

The exact determination of the inductance of round parallel conductors at short distances from each other thus is only of theoretical, but rarely of practical, importance.

An approximate estimate of the inductance L_3 is given by considering two extreme cases:

(a) The return conductor is of the shape Fig. 70, that is, from $s - r$ to $s + r$ the m.m.f. varies uniformly.

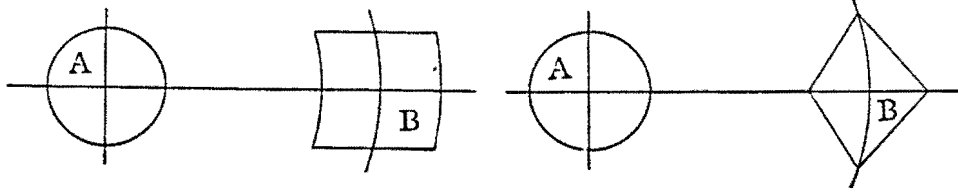

Fig. 70.

Fig. 71.

Inductance Calculation of Cable.

(b) The return conductor is of the shape Fig. 71, that is, the m.m.f. of the return conductor increases uniformly from $s - r$ to s , and then decreases again from s to $s + r$.

(a) For $s - r < x < s + r$, it is

$$\frac{F}{i} = \frac{s + r - x}{2r} = \frac{s + r}{2r} - \frac{x}{2r}, \tag{16}$$

hence by (8),

$$\begin{aligned} L_3 &= \int_{s-r}^{s+r} \frac{s+r}{r} \frac{dx}{x} - \int_{s-r}^{s+r} \frac{dx}{r} \\ &= \frac{s+r}{r} \log \frac{s+r}{s-r} - 2, \end{aligned} \tag{17}$$

by the approximation

$$\log(1 \pm x) = \pm x + \frac{x^2}{2} \pm \dots \tag{18}$$

E. Conductor with ground return.

50. As seen in the preceding, in the electric field of conductor A and return conductor B , at distance s from each other, Fig. 9, the lines of magnetic force from conductor A to the center line CC' are equal in number and in magnetic energy to the lines of magnetic force which surround the conductor in Fig. 67, in concentric circles up to the distance s , and give the inductance L of conductor A . The lines of dielectric force which radiate from conductor A up to the center line CC' , Fig. 9, are equal in number and in dielectric energy to the lines of dielectric force which issue as straight lines from the conductor, Fig. 8, up to the distance s , and represent the capacity C of the conductor A . The center line CC' is a dielectric equipotential line, and a line of magnetic force, and therefore, if it were replaced by a conducting plane of perfect conductivity, this would exert no effect on the magnetic or the dielectric field between the conductors A and B .

If then, in the electric field between overhead conductor and ground, we consider the ground as a plane of perfect conductivity, we get the same electric field as between conductor A and central plane CC' in Fig. 9. That is, the equations of inductance and capacity of a conductor with return conductor at distance s can be immediately applied to the inductance and capacity of a conductor with ground return, by using as distance s twice the distance of the conductor from the ground return. That is, the inductance and capacity of a conductor with ground return are the same as the inductance and capacity of the conductor against its *image conductor*, that is, against a conductor at the same distance below the ground as the conductor is above ground.

As the distance s between conductor and image conductor in the case of ground return is very much larger — usually 10 and more times — than the distance between conductor and overhead return conductor, the inductance of a conductor with ground return is much larger, and the capacity smaller, than that of the same conductor with overhead return. In the former case, however, this inductance and capacity are those of the entire circuit, since the ground return, as conducting plane, has no inductance and capacity; while in the case of overhead return, the inductance of the entire circuit of conductor and return conductor is twice, the capacity half, that of a single conductor, and therefore the total inductance of a circuit of two overhead conductors is greater,

in absolute units, hence, reduced to farads,

$$C = \frac{\kappa 10^9}{2 v^2 \log \frac{s}{r}} f \text{ per cm.}, \quad (37)$$

and in air, for $\kappa = 1$:

$$C = \frac{10^9}{2 v^2 \log \frac{s}{r}} f \text{ per cm.} \quad (38)$$

is the capacity, per conductor, or "capacity to neutral," as often stated.

Immediately it follows: the external inductance was, by (9),

$$L_1 = 2 \log \frac{s}{r} 10^{-9} h \text{ per cm.},$$

and multiplying this with (38) gives

$$\left. \begin{aligned} CL_1 &= \frac{1}{v^2}, \\ \text{or} \\ C &= \frac{1}{v^2 L_1}; \end{aligned} \right\} \quad (39)$$

that is, the capacity equals the reciprocal of the external inductance L_1 times the velocity square of light. The external inductance L_1 would be the inductance of a conductor which had perfect conductivity, or zero losses of power. It is

$$v' = \frac{1}{\sqrt{LC}}$$

= velocity of propagation of the electric field, and this velocity is less than the velocity of light, due to the retardation by the power dissipation in the conductor, and becomes equal to the velocity of light v if there is no power dissipation, and, in the latter case, L would be equal to L_1 , the external inductance.

The equation (39) is the most convenient to calculate capacities in complex systems of circuits from the inductances, or inversely, to determine the inductance of cables from the measured capacity, etc. More complete, this equation is

$$CL_1 = \frac{\kappa \mu}{v^2}, \quad (40)$$

where κ = specific capacity or permittivity, μ = permeability of the medium.

tion available for the return current, assuming its effective width as 800 feet, would be 80,000 square feet, or 60 million times greater than the section of the overhead conductor.

Thus only with very high resistance soil, as very dry sandy soil, or rock, can a considerable increase of the inductance of the overhead conductor be expected over that calculated by the assumption of the ground as perfect conductor.

F. Mutual induction between circuits.

51. The mutual inductance between two circuits is the ratio of the current in one circuit into the magnetic flux produced by this current and interlinked with the second circuit. That is,

$$L_m = \frac{\Phi_2}{i_1} = \frac{\Phi_1}{i_2},$$

where Φ_2 is the magnetic flux interlinked with the second circuit, which is produced by current i_1 in the first circuit.

○ A In the same manner as the self-inductance L , the mutual inductance L_m between two circuits is calculated; while the (external) self-inductance corresponds to the magnetic flux between the distances r and s , the mutual inductance of a conductor

○ B A upon a circuit ab corresponds to the magnetic flux produced by the conductor A and passing between the distances Aa and Ab , Fig. 73.

b a

Fig. 73.

Thus the mutual inductance between a circuit AB and a circuit ab is mutual inductance of A upon ab ,

$$L_m' = 2 \log \frac{Aa}{Ab} \times 10^{-9} h,$$

mutual inductance of B upon ab ,

$$L_m'' = 2 \log \frac{Ba}{Bb} \times 10^{-9} h,$$

hence mutual inductance between circuits AB and ab ,

$$\begin{aligned} L_m &= L_m'' - L_m', \\ &= 2 \log \frac{Ba \times Ab}{Aa \times Bb} 10^{-9} h, \end{aligned} \tag{41}$$

where Aa , Ab , Ba , Bb are the distances between the respective conductors, as shown in Fig. 74.

thus

$$L_m = \frac{2 S s \cos \phi \cos \psi}{D^2} 10^{-9} h. \quad (43)$$

For $\phi = 90$ degrees or $\psi = 90$ degrees, L_m is a minimum, and the approximation (43) vanishes.

G. Mutual capacity between circuits.

52. The mutual capacity between two circuits is the ratio of the voltage between the conductors of one circuit into the dielectric flux produced by this voltage between the conductors of the other circuit. That is

$$C_m = \frac{\Psi_2}{e_1} = \frac{\Psi_1}{e_2},$$

where Ψ_2 is the dielectric flux produced between the conductors of the second circuit by the voltage e_1 between the conductors of the first circuit.

If $e =$ voltage between conductors A and B , the dielectric flux of conductor A is, by (36),

$$\Psi = Ce = \frac{\kappa e}{2 v^2 \log \frac{S}{R}}, \quad (44)$$

where R is the radius of these conductors and S their distance from each other.

This dielectric flux produces, by (32), between the distances Aa and Ab , the potential difference

$$e' = \frac{2 v^2 \Psi}{\kappa} \log \frac{Aa}{Ab}, \quad (45)$$

and the dielectric flux of conductor B produces the potential difference

$$e'' = \frac{2 v^2 \Psi}{\kappa} \log \frac{Ba}{Bb}; \quad (46)$$

hence the total potential difference between a and b is

$$e'' - e' = \frac{2 v^2 \Psi}{\kappa} \log \frac{Ab Ba}{Aa Bb}; \quad (47)$$

substituting (44) into (47),

$$e'' - e' = \frac{e}{\log \frac{S}{R}} \log \frac{Ab Ba}{Aa Bb},$$

the capacity less, than that of a single conductor with ground return.

The conception of the image conductor is based on that of the ground as a conducting plane of perfect conductivity, and assumes that the return is by a current sheet at the ground surface. As regards the capacity, this is probably almost always the case, as even dry sandy soil or rock has sufficient conductivity to carry, distributed over its wide surface, a current equal to the capacity current of the overhead conductor. With the magnetic field, and thus with the inductance, this is not always the case, but the conductivity of the soil may be much below that required to conduct the return current as a surface current sheet. If the return current penetrates to a considerable depth into the ground, it may be represented approximately as a current sheet at some distance below the ground, and the "image conductor" then is not the image of the overhead conductor below ground, but much lower; that is, the distance s in the equation of the inductance is more, and often much more, than twice the distance of the overhead conductor above ground. However, even if the ground is of relatively low conductivity, and the return current thus has to penetrate to a considerable distance into the ground, the inductance of the overhead conductor usually is not very much increased, as it varies only little with the distance s . For instance, if the overhead conductor is $\frac{1}{2}$ inch diameter and 25 feet above ground, then, assuming perfect conductivity of the ground surface, the inductance would be

$$r = \frac{1}{4}''; s = 2 \times 25' = 600'', \text{ hence } \frac{s}{r} = 2400,$$

and

$$L = 2 \left\{ \log \frac{s}{r} + \frac{1}{4} \right\} 10^{-9} = 16.066 \times 10^{-9} h.$$

If, however, the ground were of such high resistance that the current would have to penetrate to a depth of over a hundred feet, and the mean depth of the ground current were at 50 feet, this would give $s = 2 \times 75' = 1800''$, hence $\frac{s}{r} = 7200$, and

$$L = 18.264 \times 10^{-9} h,$$

or only 13.7 per cent higher. In this case, however, the ground sec-

and the dielectric flux produced by the potential difference $e'' - e'$ between the conductors a and b is

$$\Psi_m = \frac{\kappa e}{2 v^2 \log \frac{s}{r} \log \frac{S}{R}} \log \frac{Ab Ba}{Aa Bb},$$

hence the mutual capacity

$$C_m = \frac{\kappa}{2 v^2 \log \frac{s}{r} \log \frac{S}{R}} \log \frac{Ab Ba}{Aa Bb} 10^9 f, \quad (48)$$

or, by approximation (18), as in (43),

$$C_m = \frac{\kappa S s \cos \phi \cos \psi}{2 D^2 v^2 \log \frac{s}{r} \log \frac{S}{R}} 10^9 f. \quad (49)$$

This value applies only if conductors A and B have the same voltage against ground, in opposite direction, as is the case if their neutral is grounded.

If the voltages are different, e_1 and e_2 , where $e_1 + e_2 = 2e$, as for instance one conductor grounded:

$$e_1 = 0, e_2 = e, \quad (50)$$

the dielectric fluxes of the two conductors are different, and that of A is: $c_1 \Psi$; that of B is: $c_2 \Psi$, where

$$\left. \begin{aligned} c_1 &= \frac{e_1}{e}, \\ c_2 &= \frac{e_2}{e}, \end{aligned} \right\} \quad (51)$$

and

$$c_1 + c_2 = 2,$$

the equations (45) to (49) assume the forms:

$$e' = \frac{2 v^2 c_1 \Psi}{\kappa} \log \frac{Aa}{Ab}, \quad (52)$$

$$e'' = \frac{2 v^2 c_2 \Psi}{\kappa} \log \frac{Ba}{Bb}, \quad (53)$$

$$e'' - e' = \frac{2 v^2 \Psi}{\kappa} \left\{ c_2 \log \frac{Ba}{Bb} - c_1 \log \frac{Aa}{Ab} \right\}, \quad (54)$$

$$\begin{aligned}
 C_m &= \frac{\kappa}{2 v^2 \log \frac{s}{r} \log \frac{S}{r}} \left\{ c_2 \log \frac{Ba}{Bb} - c_1 \log \frac{Aa}{Ab} \right\} 10^{-9} f \\
 &= \frac{\kappa}{2 v^2 \log \frac{s}{r} \log \frac{S}{R}} \log \left(\frac{Ab}{Aa} \right)^{c_1} \left(\frac{Ba}{Bb} \right)^{c_2} 10^{-9} f,
 \end{aligned} \quad (55)$$

and by (42):

$$\begin{aligned}
 &\left\{ c_2 \log \frac{Ba}{Bb} - c_1 \log \frac{Aa}{Ab} \right\} \\
 &= + c_2 \left\{ \log \left(1 - \frac{S \cos \phi - s \cos \psi}{2D} \right) - \log \left(1 - \frac{S \cos \phi + s \cos \psi}{2D} \right) \right\} \\
 &- c_1 \left\{ \log \left(1 + \frac{S \cos \phi + s \cos \psi}{2D} \right) - \log \left(1 + \frac{S \cos \phi - s \cos \psi}{2D} \right) \right\}
 \end{aligned}$$

and this gives:

$$= \frac{(c_2 - c_1) s \cos \psi}{D} + \frac{(c_1 + c_2) S s \cos \phi \cos \psi}{2 D^2}, \quad (56)$$

hence

$$C_m = \frac{\kappa}{2 v^2 \log \frac{s}{r} \log \frac{S}{R}} \left\{ (c_2 - c_1) \frac{s \cos \psi}{D} + (c_1 + c_2) \frac{S s \cos \phi \cos \psi}{2 D^2} \right\} 10^9 f \quad (57)$$

and for $e_1 = 0$, and thus $c_1 = 0$, $c_2 = 2$:

$$C_m = \frac{\kappa s \cos \psi}{D v^2 \log \frac{s}{r} \log \frac{S}{R}} \left\{ 1 + \frac{S \cos \phi}{2 D} \right\} 10^9 f, \quad (58)$$

hence very much larger than (49). However, equation (58) applies only, if the ground is at a distance very large compared with D , as it does not consider the ground as the static return of the conductor B .

H. The three-phase circuit.

53. The equations of the inductance and the capacity of a conductor

$$L = 2 \left\{ \log \frac{s}{r} + \frac{\mu}{4} \right\} 10^{-9} h, \quad (26)$$

$$C = \frac{\kappa}{2 v^2 \log \frac{s}{r}} 10^9 f \quad (37)$$

$$L = 2 \left\{ \log \frac{s}{r} + \frac{\mu}{4} \right\} 10^{-9} h. \quad (62)$$

With respect to the other outside conductor:

$$L = 2 \left\{ \log \frac{2s}{r} + \frac{\mu}{4} \right\} 10^{-9} h. \quad (63)$$

The inductance (62) applies to the component of current, which returns over the middle conductor, the inductance (63), which is larger, to the component of current which returns over the other outside conductor. These two currents are 60 degrees displaced in phase from each other. The inductance voltages, which are 90 degrees ahead of the current, thus also are 60 degrees displaced from each other. As they are unequal, their resultant is not 90 degrees ahead of the resultant current, but more in the one, less in the other outside conductor. The inductance voltage of the two outside conductors thus contains an energy component, which is positive in the one, negative in the other outside conductor. That is, a power transfer by mutual inductance occurs between the outside conductors of the three-phase circuit arranged as in Fig. 75. The investigation of this phenomenon is given by C. M. Davis in the *Electrical Review and Western Electrician* for April 1, 1911.

If the line conductors are transposed sufficiently often to average their inductances, the inductances of all three conductors, and also their capacities, become equal, and can be calculated by using the average of the three distances s , s , $2s$ between the conductors, that is, $\frac{4}{3}s$, or more accurately, by using the average of the $\log \frac{s}{r}$, $\log \frac{s}{r}$ and $\log \frac{2s}{r}$, that is:

$$\frac{2 \log \frac{s}{r} + \log \frac{2s}{r}}{3}. \quad (64)$$

In the same manner, with any other configuration of the line conductors, in case of transposition the inductance and capacity can be calculated by using the average value of the $\log \frac{s}{r}$ between the three conductors.

The calculation of the mutual inductance and mutual capacity between the three-phase circuit and a two-wire circuit is made

in the same manner as in equation (41), except that three terms appear, and the phases of the three currents have to be considered.

Thus, if A, B, C are the three three-phase conductors, and a and b the conductors of the second circuit, as shown in Fig. 76, and if i_1, i_2, i_3 are the three currents, with their respective phase angles $\gamma_1, \gamma_2, \gamma_3$, and i the average current, denoting:

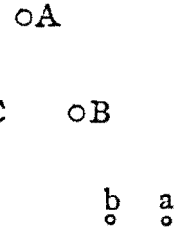

Fig. 76.

$$c_1 = \frac{i_1}{i}; \quad c_2 = \frac{i_2}{i}; \quad c_3 = \frac{i_3}{i};$$

conductor A gives:

$$L_m' = 2 c_1 \cos(\beta - \gamma_1) \log \frac{Aa}{Ab},$$

conductor B :

$$L_m'' = 2 c_2 \cos(\beta - 120^\circ - \gamma_2) \log \frac{Ba}{Bb},$$

conductor C :

$$L_m''' = 2 c_3 \cos(\beta - 240^\circ - \gamma_3) \log \frac{Ca}{Cb};$$

hence,

$$L_m = 2 \left\{ c_1 \cos(\beta - \gamma_1) \log \frac{Aa}{Ab} + c_2 \cos(\beta - 120^\circ - \gamma_2) \log \frac{Ba}{Bb} + c_3 \cos(\beta - 240^\circ - \gamma_3) \log \frac{Ca}{Cb} \right\} 10^{-9} h,$$

and in analogous manner the capacity C_m is derived.

In these expressions, the trigonometric functions represent a rotation of the inductance combined with a pulsation.

INDEX.

	PAGE
Acceleration as mechanical transient.....	4
single-energy transient.....	8
Admittance, natural or surge, of circuit.....	61, 84
Alternating current in line as undamped oscillation.....	97
phenomena as transients.....	9
reduction to permanents.....	9
Alternators, momentary short-circuit currents.....	37
construction.....	40
calculation.....	44
Arcing grounds.....	97
as cause of cumulative oscillations.....	120
Armature transient of alternator short circuit.....	41
Attenuation of transient, <i>see</i> Duration.	
Cable inductance, calculation.....	81, 132
surge.....	62
Capacity.....	18
calculation.....	136
of circuit, definition.....	12
current.....	13
definition.....	128
effective, of line transient.....	75
equation.....	138
and inductance calculation of three-phase circuit.....	145
CAPACITY AND INDUCTANCE OF ROUND PARALLEL	
CONDUCTORS.....	128
Capacity, mutual, calculation.....	143, 147
specific.....	16, 17, 18
Charge, electric, of conductor.....	14
Charging current.....	13
Circuit, dielectric.....	14, 17, 18
of distributed capacity and inductance, also <i>see</i> Line.	
electric.....	17, 18
magnetic.....	14, 17, 18
Closed compound-circuit transient.....	111, 112
Combination of effective and reactive power.....	100
transient.....	100
of standing and traveling waves.....	100
COMPOUND CIRCUIT OSCILLATION.....	108
Compound circuit, power flow.....	90
velocity unit of length.....	92
oscillation of closed circuit.....	111, 112
of open circuit.....	114
Condenser current.....	13
Conductance.....	18
effective, of line transient.....	78
Conductivity, electric.....	18
CONTINUAL AND CUMULATIVE OSCILLATIONS.....	119
Continual energy supply in continual and cumulative oscillations.....	119, 123
oscillation of hunting synchronous machines.....	124
Continuous oscillation.....	120

	PAGE
Energy, dielectric and magnetic, of transient.....	67
magnetic.....	18
of magnetic field.....	12
storage as cause of transients.....	3
supply in continual and cumulative oscillations.....	119, 123
transfer in double-energy transient.....	60
by traveling wave.....	92
of traveling wave in compound circuit.....	110
Equations of double-energy transient.....	69
line oscillation.....	74, 75, 84
simple transient.....	6
single-energy magnetic transient.....	21, 24
Excessive momentary short circuit of alternator.....	37
Exponential decrement.....	88
magnetic single-energy transient.....	21
transient.....	7
numerical values.....	23
Field current at alternator short circuit, rise.....	40
transient pulsation.....	43
permanent pulsation.....	45
FIELD, ELECTRIC.....	10
rotating, transient.....	34
superposition.....	129
transient, of alternator.....	38
construction.....	40
calculation.....	44
Flux, dielectric.....	11, 15
magnetic.....	10, 14
Frequencies of line oscillations.....	79
Frequency of double-energy transient, calculation.....	66
of continual and cumulative oscillations.....	126
oscillation of line transient.....	78
transformation in continual and cumulative oscillations.....	119
Fröhlich's formula of magnetic-flux density.....	53
Fundamental wave of oscillation.....	81
Gradient, electric.....	15, 17, 18
Grounded phase.....	97
Grounding surge of circuit.....	62
Ground return of conductor, inductance and capacity.....	139
Half-wave oscillation.....	82
Hunting of synchronous machines as double-energy transient.....	9
as continual or cumulative oscillation.....	124
Hydraulic transient of water power.....	4
Hysteresis cycle as cause of continual or cumulative oscillation.....	124
Image conductor of grounded overhead line.....	139
Impedance, natural or surge, of circuit.....	61, 84
Impulse propagation over line and reflection.....	105
as traveling wave.....	105
Increase of power flow in traveling wave.....	92
Independence of rotating-field transient from phase at start.....	36
Inductance of cable.....	132
calculation.....	132
and capacity calculation of three-phase circuit.....	135
INDUCTANCE AND CAPACITY OF ROUND PARALLEL CONDUCTORS.....	128

	PAGE
Inductance of circuit, definition.....	11
definition.....	128
effective, of line transient.....	75
equation.....	132, 135, 140
mutual, calculation.....	141, 147
voltage.....	12, 18
Intensity, dielectric.....	16, 17, 18
magnetic.....	15, 17, 18
IRON-CLAD CIRCUIT, SINGLE-ENERGY TRANSIENT.....	52
Iron-clad circuit transient, oscillogram.....	57
Kennelly's formula of magnetic reluctivity.....	53
Length of circuit in velocity measure, calculation.....	109
Lightning surge of circuit.....	62
as traveling wave.....	89
Line as generator of transient power.....	112
LINE OSCILLATION.....	72
general form.....	74
continual oscillation.....	124
also see Transmission line.	
Magnetic field.....	10
as stored energy.....	3
flux.....	14, 17, 18
forces.....	10
single-energy transient.....	19, 25
construction.....	20, 25
duration.....	59
Magnetics.....	14, 17, 18
Magnetizing force.....	14, 17, 18
Magnetomotive force.....	14, 17, 18
Massed capacity and inductance.....	73
Maximum transient current.....	61
voltage.....	61
Maximum value of rotating-field transient.....	36
Measurement of very high frequency traveling wave.....	104
Mechanical energy transient.....	4
Mechanism of energy supply in continual or cumulative oscillation.....	124
Momentary short-circuit current of alternators.....	37
construction.....	40
calculation.....	44
Motor field, magnetic transient.....	24
Mutual capacity, calculation.....	143, 147
of lines, calculation.....	81
inductance and capacity with three-phase circuit.....	147
calculation.....	141, 147
Natural admittance and impedance of circuit.....	61, 84
Negative energy cycle of continual and cumulative oscillations.....	124
Nonperiodic transient.....	9
Nonproportional electric transient.....	52
surge of transformer.....	64
Open-circuit compound oscillation.....	113
Oscillating currents.....	62
voltages.....	62
Oscillation frequency of line transient.....	78

	PAGE
Oscillation of open compound circuit.....	113
stationary, <i>see</i> Stationary oscillations and standing waves.	
Oscillations, cumulative.....	97
of closed compound circuit.....	111, 112
OSCILLATIONS, LINE.....	72
OSCILLATIONS OF THE COMPOUND CIRCUIT.....	108
Oscillatory transient of rotating field.....	36
Oscillograms of arcing ground on transmission line.....	98
continual oscillations.....	121-123
continuous oscillations.....	123
cumulative transformer oscillation.....	99
decay of compound circuit.....	91
formation of stationary oscillation by reflection of traveling wave.....	101
high-frequency waves preceding low-frequency oscillation of compound circuit.....	102, 103
impulses in line and their reflection.....	106
recurrent oscillations.....	121, 122
single-phase short circuit of alternators.....	50
single-phase short circuit of quarter-phase alternator.....	48
three-phase short circuit of alternators.....	49
starting current of transformer.....	57
starting oscillation of transmission line.....	76, 77
varying frequency transient of transformer.....	64
Pendulum as double-energy transient.....	8
Periodic component of double-energy transient, equation.....	66
energy transfer in transient.....	60
and transient component of transient.....	72
transients, reduction to permanents.....	9
Period and wave length in velocity units.....	92
Permanent phenomena, nature.....	1
Permeability.....	15, 17, 18
Permeance.....	18
Permittance.....	18
Permittivity.....	16, 17, 18
Phase angle, change at transition point.....	117
of oscillation, progressive change in line.....	75
Phenomena, transient, <i>see</i> Transients.	
Polyphase alternator short circuit.....	44
oscillograms.....	48, 49
Power diagram of open compound-circuit transient.....	114
closed compound-circuit transient.....	111, 113
dissipation constant.....	88
of section of compound circuit.....	108
double-energy transient.....	66
electric.....	18
flow in compound circuit.....	90
of line transient.....	88, 89
of line oscillation.....	79
supply to continual or cumulative oscillation.....	126
transfer constant of circuit.....	94
section of compound circuit.....	108
in compound-circuit oscillation.....	90
of traveling wave.....	95
Progressive change of phase of line oscillation.....	75
Propagation of transient in line.....	74
velocity of electric field.....	74
field.....	138

	PAGE
Proportionality in simple transient.....	4
Protection against continual oscillations.....	126
Pulsation, permanent, of field current in single-phase alternator short circuit.....	45
of transient energy.....	61
transient, of magnetomotive force and field current at poly-phase alternator short circuit.....	41
Quadrature relation of stationary wave.....	88
Quantity of electricity.....	14
Quarter-wave oscillation of line.....	81, 82
Reactance of alternator, synchronous and self-inductive.....	37
Reaction, armature, of alternator.....	37
Reactive power wave.....	88
Recurrent oscillations.....	120, 124
Reflected wave at transition point.....	118
Reflection at transition point.....	118
Relation between capacity and inductance of line.....	81
standing and traveling waves.....	101
Reluctance.....	18
Reluctivity.....	18
Resistance.....	18
effective, of line transient.....	78
Resistivity.....	18
Resolution into transient and permanent.....	30
Rise of field current at alternator short circuit.....	40
Rotating field, transient.....	34
Self-induction, e.m.f. of.....	12
Separation of transient and permanent.....	27, 30
Ships, deceleration as transient.....	7
Short-circuit of alternator, momentary.....	37
construction.....	40
calculation.....	44
surge of circuit.....	62
Simple transient.....	4
equation.....	6
Singing arc.....	122
Single-phase alternator short circuit.....	45
oscillogram.....	50
short circuit of alternators.....	45
oscillograms.....	48, 50
Single-energy transient.....	7
SINGLE-ENERGY TRANSIENT OF IRON-CLAD CIRCUITS..	52
SINGLE-ENERGY TRANSIENTS, CONTINUOUS CURRENT..	19
SINGLE-ENERGY TRANSIENTS IN A.C. CIRCUITS.....	30
Specific capacity.....	16, 17, 18
Standing waves.....	97
originating from traveling waves.....	101
see Stationary oscillation and Oscillation, stationary.	
Start of standing wave by traveling wave.....	101
Starting current of transformer, oscillogram.....	57
oscillation of line.....	86
transmission line, oscillogram.....	76, 77
of rotating field.....	34
transient of A.C. circuit.....	32
magnetic circuit.....	28
three-phase circuit.....	32

	PAGE
Static induction of line, calculation.....	81
Stationary oscillation of open line.....	86
<i>see</i> Line oscillation and Standing wave.	
Steepness of iron-clad transient.....	58
wave front and power-transfer constants of impulse.....	105
Step-by-step method of calculating transient of iron-clad circuit.....	53
Storage of energy as cause of transients.....	3
Superposition of fields.....	129
Surge admittance and impedance of circuit.....	61, 84
Symbolic method reducing A.C. phenomena to permanents.....	9
Symmetrical pulsation of field current at single-phase alternator short circuit.....	45
Synchronous machine hunting.....	124
Terminal conditions of line oscillation.....	84
Three-phase alternator short circuit.....	44
oscillograms.....	49
Three-phase circuit, inductance and capacity calculations.....	145
mutual inductance and capacity.....	147
current transient.....	32
magnetic-field transient.....	34
Time constant.....	22
decrement.....	94
of compound circuit.....	108
Transfer of energy in double-energy transient.....	60
by traveling wave.....	92
in compound circuit oscillation.....	90
Transformation ratio at transition point of compound circuit.....	117
Transformer as generator of transient energy.....	111, 113
continual oscillation.....	127
surge.....	62
Transient current in A.C. circuit.....	31
double-energy.....	7
power transfer in compound-circuit.....	112
single-energy.....	7
of rotating field.....	34
self-inductive reactance of alternator.....	51
separation from permanent.....	27, 30
short-circuit current of alternator.....	37
construction.....	40
calculation.....	44
and periodic components of oscillation.....	72
Transients, double-energy.....	59
caused by energy storage.....	3
fundamental condition of appearance.....	4
general with all forms of energy.....	4
as intermediate between permanents.....	2
nature.....	1
single-energy A.C. circuit.....	30
continuous current.....	19
Transition point, change of phase angle.....	117
reflection.....	118
voltage and current transformation.....	117
Transmission-line surge.....	63
transient.....	73
<i>also see</i> Line.	
Transmitted wave at transition point.....	118
Transposition of line conductors.....	147

	PAGE
TRAVELING WAVES.....	88
Traveling wave, equation.....	95
as impulses.....	105
preceding stationary oscillation.....	101
of very high frequency.....	104
Turboalternators, momentary short-circuit current.....	37
construction.....	40
calculations.....	44
Undamped oscillations.....	97
Unidirectional energy transfer in transient.....	60
Uniform power flow in traveling wave.....	92
Unsymmetrical pulsation of field current at single-phase alternator short circuit.....	46
Varying frequency oscillation of transformer.....	64
Velocity constant of line.....	78, 83
relation between line capacity and inductance.....	81
measure, calculation of circuit length.....	109
of propagation of electric field.....	74, 138
transient of ship.....	7
unit of length of line.....	83
of length in compound circuit.....	92
Very high frequency traveling wave.....	104
Voltage.....	18
gradient.....	15, 17
relation of section of compound oscillating circuit.....	17
rise of quadrature phase in single-phase alternator short circuit.....	47
at transition point of compound oscillation.....	117
of single-energy magnetic transient.....	27
transient, maximum.....	61
Wave front of impulse.....	105
length of line oscillation.....	79, 80
and period in velocity unit.....	92
standing, <i>see</i> Standing wave.	
WAVES, TRAVELING.....	88

Copyright, 1911,
By The
McGraw-Hill Book Company

1988 Reprint Edition By:



P.O. Box 220 ★ Bayside, California ★ 95524 USA