

Imaging of Optical Modes — Resonators with Internal Lenses

By HERWIG KOGELNIK

(Manuscript received November 10, 1964)

This paper discusses the modes of optical resonators, and optical modes of propagation or Gaussian beams of light. The passage of Gaussian beams through lenses, telescopes, sequences of lenses, and lenslike media is studied. Mode matching formulae are derived. A complex beam parameter is introduced for which the law of transformation by any given optical structure can be written in the simple form of a bilinear transformation (ABCD law). Resonators with internal optical elements and their transmission line duals are also investigated. Effective Fresnel numbers and curvature parameters are determined which allow one to infer the diffraction losses, the resonant conditions, and the mode patterns of the various systems. Results are obtained for resonators with internal lenses, sequences of lenses with irises inserted between the lenses, resonators with internal lenslike media, transmission lines consisting of a lenslike medium with periodically spaced irises, and resonators with one very large mirror.

I. INTRODUCTION

The theory of Fresnel diffraction is the basis for an understanding of optical resonators¹⁻⁵ and of optical modes of propagation.^{2,3,4} Fresnel diffraction explains the mode patterns and diffraction losses of optical resonators, and the beam waist and spreading of the modes of propagation or "Gaussian beams." In this paper we will discuss how these Gaussian beams of light are transformed on their passage through lenses, telescopes, various lens combinations, and lenslike (guiding) media, and how these optical systems affect the properties of optical resonators when inserted between the resonator mirrors.

We will assume that no additional aperture diffraction effects are introduced by these optical systems, i.e., that the apertures of the internal lenses can be regarded as infinitely large. The imaging laws of geometrical optics are therefore expected to apply, and we will use them

wherever possible, as they generally simplify the algebraic derivations and at the same time provide some physical insight.

Some of the problems to be investigated here in greater detail have already been treated in the literature. Goubau⁶ has given some mathematical relations between the parameters of Gaussian beams transformed by a thin lens. The recently published mode matching formulae⁷ are the result of a computation which will now be presented. Resonators with internal lenses have also been discussed in the literature,⁸⁻¹¹ and we have used the concept of an effective distance^{9,10} in a previous publication.⁹ In several cases an alternative to our algebraic approach is the graphical method of Collins,¹¹ who introduced the circle diagram^{11,12} for Gaussian beams.

In the following we will first establish the rules of imaging for Fresnel diffraction with attention to the imaging of the phase fronts which are of particular importance for optical modes. Then we will list expressions for the focal length and the principal planes of various optical systems of interest, because these parameters are needed later for application of the imaging rules. This listing includes the parameters of the telescope, of sequences of lenses, and of sections of lenslike medium. Armed with these tools we will study the passage of Gaussian beams through lenses and various optical systems. The paper is concluded by an investigation of optical resonators with internal optical elements and their transmission line duals. Effective Fresnel numbers and curvature parameters are determined which allow one to infer the diffraction losses, the resonant conditions, and the mode patterns of the various systems. Results are obtained for resonators with internal lenses, sequences of lenses with irises inserted between the lenses, resonators with internal lenslike media, transmission lines consisting of a guiding medium with periodically spaced irises, and resonators with one very large mirror.

II. IMAGING RULES

While geometrical optics deals with rays, the theory of Fresnel diffraction deals with (scalar) fields. To describe the field distribution, we use complex amplitudes $E(x,y,z)$ and a Cartesian (x,y,z) coordinate system. We consider a wave that propagates in the direction of the optic axis (z axis). Within the assumptions of Fresnel diffraction an ideal thin lens of focal length f transforms the incoming wave with a field $E_{\text{left}}(x,y,z = \text{const})$ immediately to the left of the lens into a wave with the field

$$E_{\text{right}}(x,y,z = \text{const}) = E_{\text{left}}(x,y,z = \text{const}) \exp\left(-jk \frac{x^2 + y^2}{2f}\right) \quad (1)$$

immediately to the right of the lens. Here k is the propagation constant. The thin lens produces a phase shift which is proportional to the square of the distance to the optic axis, while the intensity distribution is the same on both sides of the lens.

Consideration of spherical waves provides a link between (1) and the laws of geometrical optics according to which a spherical wave with a radius of curvature R_1 at the left of the lens is transformed into a wave with curvature radius R_2 as shown in Fig. 1. The radii R_1 and R_2 are related by

$$(1/R_1) + (1/R_2) = 1/f. \quad (2)$$

For Fresnel diffraction the transverse field distribution of a wave with a spherical phase front of radius R is given^{2,3} by

$$E(x,y,z = \text{const}) = \exp(-jkr^2/2R) \quad (3)$$

where

$$r^2 = x^2 + y^2, \quad (4)$$

and R is counted positive for a phase front that is concave if observed from the left. For spherical phase fronts of radius R_1 on the left and $-R_2$ on the right of the lens (where the phase front curvature is negative, as shown in Fig. 1) we can express E_{left} and E_{right} with the help of (3), compare the exponents in (1), and find the same relation (2) between R_1 , R_2 , and f as for the spherical waves of geometrical optics.

To discuss imaging consider an object, i.e., the field $E_1(x_1, y_1)$ in an object plane, and its image $E_2(x_2, y_2)$ in the corresponding image plane (see Fig. 2). The distances d_1 and d_2 between the lens and the two planes are related by

$$(1/d_1) + (1/d_2) = 1/f. \quad (5)$$

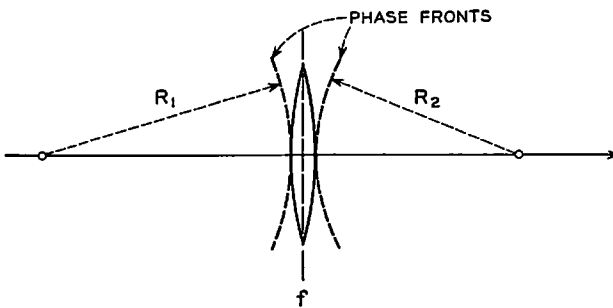

Fig. 1 — Lens transforming phase front of spherical wave.

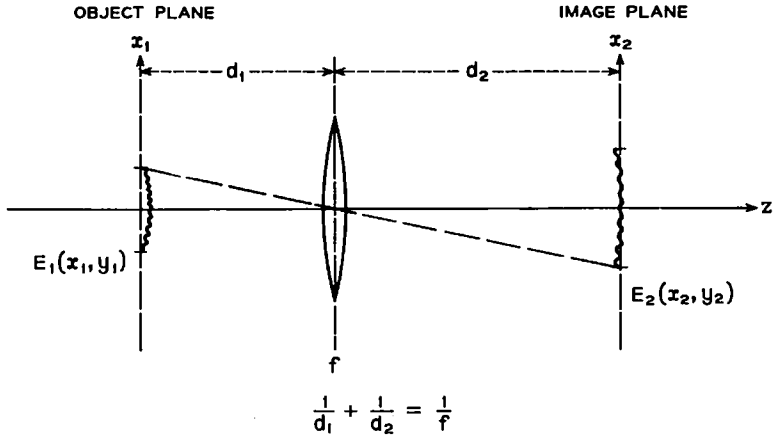

Fig. 2 — Imaging of field distribution by a thin lens.

We know from geometrical optics that the intensity distributions of the object and the image are similar. This is, of course, still true for Fresnel diffraction by any field aperture in the object plane. Assuming that no aperture diffraction effects are introduced by the thin lens, one can use the Fresnel diffraction formula to relate E_1 and E_2 (see Appendix A) and arrive at

$$E_2(x_2, y_2) = -\frac{d_1}{d_2} E_1\left(-\frac{d_1}{d_2}x_2, -\frac{d_1}{d_2}y_2\right) \cdot \exp -jk\left(d_1 + d_2 + \frac{r_2^2}{2f} \frac{d_1}{d_2}\right) \quad (6)$$

with $r_2^2 = x_2^2 + y_2^2$. The factor d_1/d_2 in this equation follows from conservation of energy; the arguments $-(d_1/d_2)x_2$ and $-(d_1/d_2)y_2$ indicate that the image is inverted and magnified by d_2/d_1 . The first two terms in the exponent are simply due to the phase shift $k(d_1 + d_2)$ which the light wave suffers in propagating from the object to the image plane, while the third and last term is of particular importance for our considerations. It describes an additional phase shift proportional to r_2^2 which appears in the field distribution of the image. Apart from this additional phase shift the amplitude and phase distribution of the image and the object are scales of each other.

The expression for the additional phase shift follows also from geometrical optics (see e.g. Appendix B), and it is related to the thick-mirror formulae,¹³ as we shall see later. It is also obtained by studying

the passage of Gaussian beams through a lens.⁶ The additional phase shift does not appear in Abbe's theory of imaging; he finds that the image is strictly similar to the object, both as regards the amplitude and phase distribution.¹⁴ But Abbe used the Fraunhofer diffraction theory, where phase terms proportional to r^2 are neglected.

For Fresnel diffraction the r^2 dependence of the additional phase shift suggests that one should use spherical reference surfaces instead of plane ones, as shown in Fig. 3. By proper choice of the curvature of these surfaces tangential to the image and object planes, one can achieve an image field on one surface that strictly reproduces the object on the other surface in amplitude and phase. For an object reference surface of radius R_1 and an image reference surface of radius R_2 one gets for the fields additional phase factors of $\exp(-jkr_1^2/2R_1)$ and $\exp(-jkr_2^2/2R_2)$, respectively. These phase factors cancel the additional phase shift in (6) if

$$\frac{1}{R_2} = \frac{1}{R_1} \frac{d_1^2}{d_2^2} + \frac{1}{f} \frac{d_1}{d_2}. \quad (7)$$

After some algebraic manipulations involving (5) this relation can be rewritten as

$$\frac{1}{d_1 + R_1} + \frac{1}{d_2 - R_2} = \frac{1}{f}. \quad (8)$$

This simply means that the center of curvature C_1 of the object surface

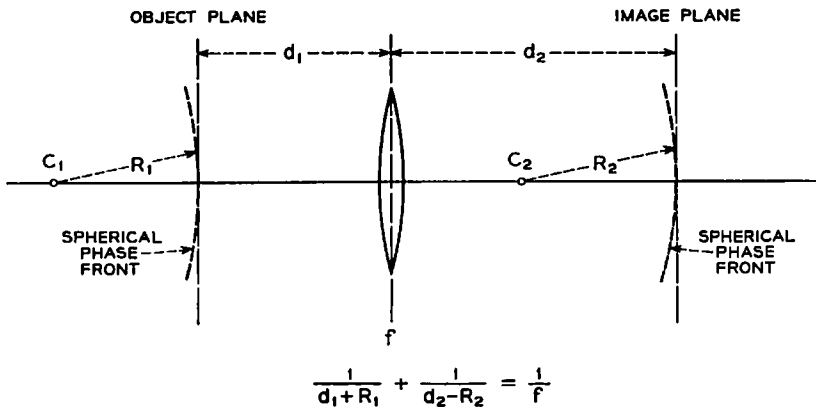

Fig. 3 — Imaging of fields with spherical wave fronts; centers of curvature are images of each other. The corresponding spherical reference surfaces are used when fields with nonspherical phase fronts are imaged.

is imaged onto the center of curvature C_2 of the image surface. Thus, whenever the centers of curvature of the image and object surfaces are images of each other we have an image which is a strict (scaled) reproduction of the object as regards both the amplitude and phase distribution, with no additional phase shift.

The imaging rules discussed above can also be used to study imaging by a combination of lenses (or by any optical system that can be regarded as such). It is not necessary to apply the rules step by step to each individual thin lens of the combination. It is generally simpler to determine the parameters of the equivalent thick lens as usual in geometrical optics. The place of f is then taken by the combined focal length of the system, and object and image distances (d_1 and d_2) are measured from the principal planes of the thick lens.

III. FOCAL LENGTHS OF VARIOUS OPTICAL SYSTEMS

3.1 *The Ray Matrix*

When one traces a paraxial ray through combinations of lenses and lenslike media, the quantities of interest are the position x_1 and the slope x_1' of the ray in the input plane, and the corresponding quantities x_2 and x_2' in the output plane (see Fig. 4). There is in general a linear relation^{15,16,17} between the output and input quantities which can be written in matrix form as

$$\begin{vmatrix} x_2 \\ x_2' \end{vmatrix} = \begin{vmatrix} A & B \\ C & D \end{vmatrix} \begin{vmatrix} x_1 \\ x_1' \end{vmatrix}. \quad (9)$$

We will call this $ABCD$ matrix the ray matrix of the system. Because of reciprocity the determinant of the ray matrix is generally unity:

$$AD - BC = 1. \quad (10)$$

It is easy to determine the focal length and the principal planes from the elements of the ray matrix of an optical system. By tracing a beam that leaves the output plane parallel to the optic axis ($x_2' = 0$) we find the location of the focal point on the input side. Its distance s_1 from the input plane is obtained as

$$s_1 = \frac{x_1}{x_1'} \bigg|_{x_2'=0} = -\frac{D}{C} \quad (11)$$

where we refer to Fig. 4. Similarly, we find for the distance s_2 between

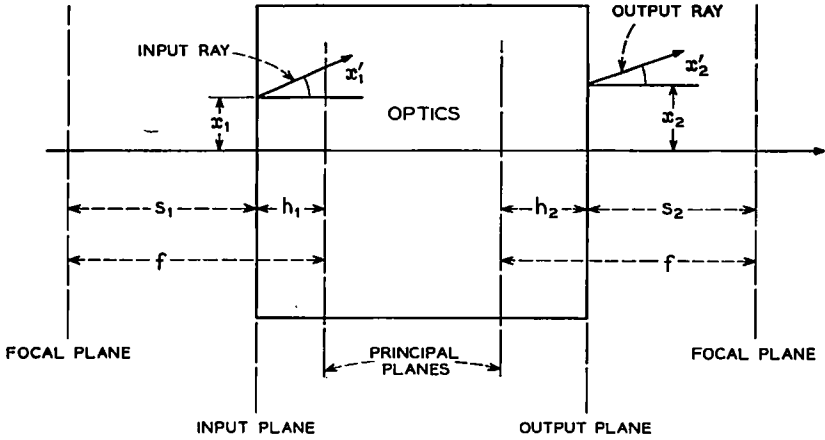

Fig. 4 — Reference planes for optical system.

the output plane and the corresponding focal point

$$s_2 = - \left. \frac{x_2}{x_2'} \right|_{x_1'=0} = - \frac{A}{C}. \quad (12)$$

To find the principal plane on the input side we follow an input ray from the focal point until its distance from the axis is equal to the position x_2 of the corresponding output ray and have

$$h_1 = \left. \frac{x_2 - x_1}{x_1'} \right|_{x_2'=0} \quad (13)$$

where the distance h_1 between the principal plane and the input plane is measured positive as shown in Fig. 4. On the output side we find similarly

$$h_2 = \left. \frac{x_2 - x_1}{x_2'} \right|_{x_1'=0}. \quad (14)$$

The focal length f of the system is obtained by calculating the distance between a principal plane and the corresponding focal point

$$f = s_1 + h_1 = s_2 + h_2 = \left. \frac{x_2}{x_1'} \right|_{x_2'=0} = - \left. \frac{x_1}{x_2'} \right|_{x_1'=0}. \quad (15)$$

Using the linear relations of (9) together with the last three expressions, one finally gets

$$f = -(1/C) \quad (16)$$

$$h_1 = (D - 1)/C \quad (17)$$

$$h_2 = (A - 1)/C \quad (18)$$

where the thick-lens parameters are expressed in terms of the elements of the ray matrix. For later use we also write down the matrix elements as functions of the lens parameters which follow from the last expressions

$$A = 1 - (h_2/f) \quad (19)$$

$$B = h_1 + h_2 - (h_1 h_2/f) \quad (20)$$

$$C = -(1/f) \quad (21)$$

$$D = 1 - (h_1/f). \quad (22)$$

3.2 The Two-Lens Combination—Telescope

The lens parameters of a combination of two lenses are well known and are listed here for completeness and for later use. The combination is shown in Fig. 5. For lenses of focal lengths f_1 and f_2 spaced at a distance d we have

$$1/f = (1/f_1) + (1/f_2) - (d/f_1 f_2) \quad (23)$$

$$h_1 = \frac{df}{f_2} \quad (24)$$

$$h_2 = \frac{df}{f_1} \quad (25)$$

where the lens planes are used as input and output planes.

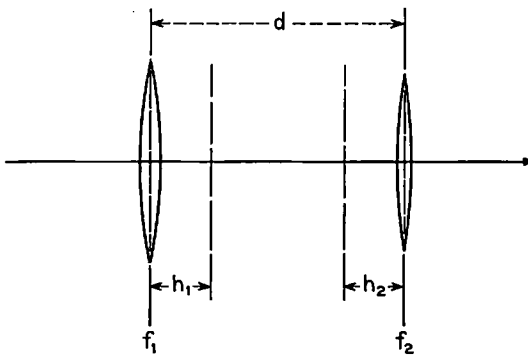

Fig. 5 — The two-lens combination.

For a slightly misadjusted telescope the lens spacing is

$$d = f_1 + f_2 - \Delta d \quad (26)$$

where Δd measures the misadjustment. The lens parameters of the telescope can be written as

$$f = \frac{f_1 f_2}{\Delta d} \quad (27)$$

$$h_1 = \frac{f_1 d}{\Delta d} \quad (28)$$

$$h_2 = \frac{f_2 d}{\Delta d}. \quad (29)$$

3.3 Sequence of Lenses

A periodic sequence of lenses of equal focal length f_0 and lens spacing d is shown in Fig. 6. The reference planes are chosen just to the right of each lens. The elements of the ray matrix \hat{S} of one section of the sequence (i.e., one lens spaced at a distance d from the input plane) are well known^{15,17} and are given by

$$\hat{S} = \begin{vmatrix} 1 & d \\ -\frac{1}{f_0} & 1 - \frac{d}{f_0} \end{vmatrix}. \quad (30)$$

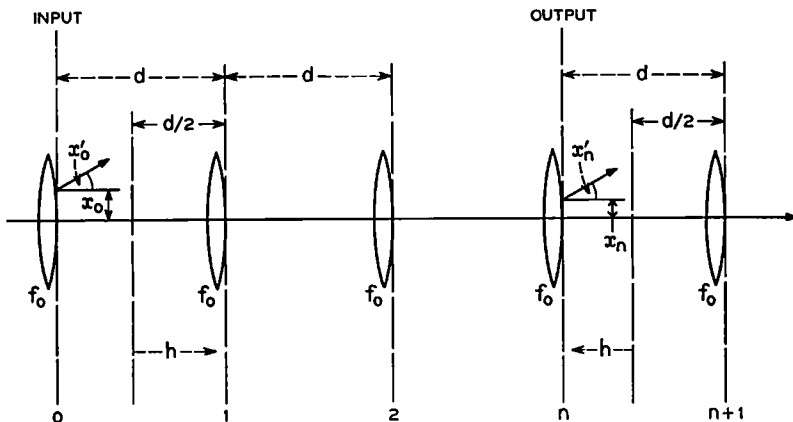

Fig. 6 — Sequence of lenses of equal focal length.

They relate the position and slope (x_1 and x_1') of the ray just after the first lens to the ray position and slope just after the zeroth lens

$$\begin{vmatrix} x_1 \\ x_1' \end{vmatrix} = \hat{S} \begin{vmatrix} x_0 \\ x_0' \end{vmatrix}. \quad (31)$$

The ray to the right of the n th lens is related to the input ray by the n th power of the ray matrix of one section

$$\begin{vmatrix} x_n \\ x_n' \end{vmatrix} = \hat{S}^n \begin{vmatrix} x_0 \\ x_0' \end{vmatrix}. \quad (32)$$

The matrix elements of \hat{S}^n can be computed with the help of Sylvester's theorem¹⁸ and are well known.^{15,16} One has*

$$\hat{S}^n = \frac{1}{\sin \theta} \begin{vmatrix} \sin n\theta - \sin(n-1)\theta & d \sin n\theta \\ -\frac{1}{f_0} \sin n\theta & \left(1 - \frac{d}{f_0}\right) \sin n\theta - \sin(n-1)\theta \end{vmatrix} \quad (33)$$

with

$$\cos \theta = 1 - (d/2f_0). \quad (34)$$

We can now employ (16) and obtain for the focal length f of n sections of a periodic sequence of lenses

$$f = f_0(\sin \theta / \sin n\theta). \quad (35)$$

The distance of the two principal planes from the input and output planes (zeroth and n th lens) follows also from (33) with the help of (17) and (18). One finds

$$h_1 = (d/2) + f(1 - \cos n\theta), \quad (36)$$

and

$$h_2 = -(d/2) + f(1 - \cos n\theta). \quad (37)$$

If we measure the distance h of the principal planes from the midplanes between the lenses as shown in Fig. 6 we have

$$h = f(1 - \cos n\theta). \quad (38)$$

*These matrix elements can be written in terms of Chebyshev polynomials of the second kind of the variable $[1 - (d/2f_0)]$.

A more complicated sequence of lenses is shown in Fig. 7. Here a lens of focal length f_1 is followed by a lens of focal length f_2 and vice versa. The lens spacings are d_1 and d_2 in sequence as shown in the figure. This sequence of lenses can be reduced to the simpler type discussed above. We can regard it as a sequence of thick lenses formed by lens pairs of focal lengths f_1 and f_2 . The focal length f_0 of the thick lens is, according to (23), given by

$$1/f_0 = (1/f_1) + (1/f_2) - (d_1/f_1f_2), \quad (39)$$

and expressions for the principal planes are given in (24) and (25). The distance d between the output principal plane of a thick lens and the input principal plane of the consecutive thick lens is obtained as

$$d = d_2 + h_1 + h_2 = d_2 + f_0d_1 \left(\frac{1}{f_1} + \frac{1}{f_2} \right). \quad (40)$$

With the principal planes as reference planes, rays passing through this sequence of thick lenses behave the same way as rays passing through a sequence of lenses of equal focal length that are equally spaced. We can therefore use the expressions (33) and (34) obtained above. With (39) and (40) the latter becomes

$$\cos \theta = 1 - \frac{d_1 + d_2}{2} \left(\frac{1}{f_1} + \frac{1}{f_2} \right) + \frac{d_1d_2}{2f_1f_2}. \quad (41)$$

3.4 Lenslike Medium

A lenslike medium or "guiding medium" is one whose refractive index n varies near the optic axis as in

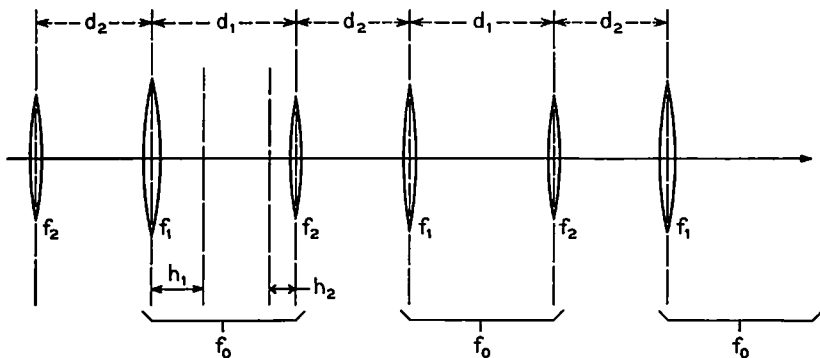

Fig. 7 — Sequence of lenses of alternating focal length with alternating lens spacings.

$$n = n_0 \left(1 - 2 \frac{r^2}{b^2} \right) \tag{42}$$

where n_0 is a constant, r is the distance from the optic axis, and b measures the degree of the variation of n . A medium of this kind can be produced by inhomogeneities in laser crystals^{19,20} or by a radial variation of the gain in high-gain gaseous lasers.²¹ Another important example is the medium of the recently reported gas lens.^{22,23,24}

To trace rays in a lenslike medium one uses the differential equation for light rays.²⁵ For paraxial rays this ray equation has the form

$$n_0 \frac{d^2 x}{dz^2} = \frac{\partial}{\partial x} n = -4n_0 \frac{x}{b^2} \tag{43}$$

for the distance $x(z)$ of the ray from the z axis. A corresponding relation holds for $y(z)$. The solution is, again, a linear relation between the ray position and slope in the output plane (x and x') and the corresponding input quantities x_0 and x'_0

$$\begin{vmatrix} x \\ x' \end{vmatrix} = \begin{vmatrix} \cos 2 \frac{z}{b} & \frac{b}{2} \sin 2 \frac{z}{b} \\ -\frac{2}{b} \sin 2 \frac{z}{b} & \cos 2 \frac{z}{b} \end{vmatrix} \begin{vmatrix} x_0 \\ x'_0 \end{vmatrix}. \tag{44}$$

A typical ray path is shown in Fig. 8. To calculate the optical parameters for a section of lenslike medium immersed in a medium with a refractive index of unity (vacuum), we invoke Snell's law to relate the ray slopes

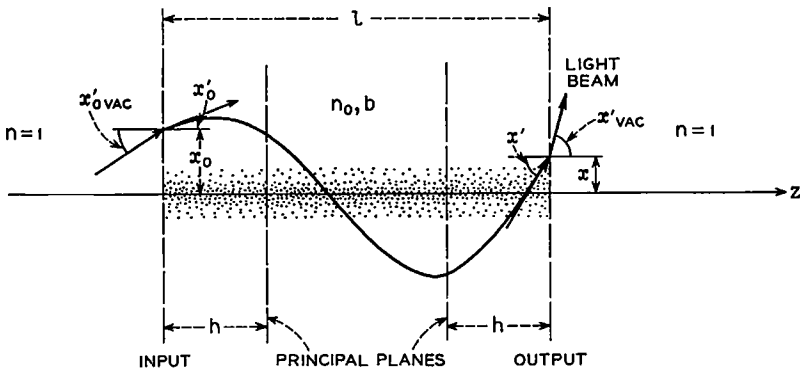

Fig. 8 — Ray path in lenslike medium.

at the section boundaries. For paraxial rays we have approximately

$$x_{vac} = n_0 x'; \quad x_{0vac} = n_0 x'_0. \quad (45)$$

Now we use (16) and find for the focal length of a section of length l

$$f = \frac{b}{2n_0 \sin 2 \frac{l}{b}}. \quad (46)$$

(for $n_0 = 1$ this formula has been given in Refs. 23 and 26, for example). The distance h of the principal planes from the input and output planes respectively (see Fig. 8) is computed with the help of (17) and (18). One obtains

$$h = \frac{b}{2n_0} \tan \frac{l}{b}. \quad (47)$$

The above expressions have been derived for a focusing medium where $b^2 \geq 0$. For a defocusing medium we have $b^2 \leq 0$, and the expression for the focal length becomes

$$f = - \frac{|b|}{2n_0 \sinh 2 \frac{l}{|b|}}. \quad (48)$$

The location of the corresponding principal planes is described by

$$h = \frac{|b|}{2n_c} \tanh \frac{l}{|b|}. \quad (49)$$

IV. OPTICAL TRANSFORMATION OF GAUSSIAN BEAMS

4.1 *Light Propagation in Free Space*

Near the optic axis an optical mode of propagation or Gaussian beam is regarded as a TEM wave with a spherical phase-front and a transverse field distribution that is described by Laguerre-Gaussian² or Hermite-Gaussian³ functions. The two beam parameters of interest are the "spot size" or beam radius $w(z)$ and the radius of the phase front $R(z)$. In any beam cross section of a fundamental mode the field varies as

$$\exp \left(- \frac{r^2}{w^2} - jk \frac{r^2}{2R} \right)$$

and is specified by w and R . The light beam expands as it propagates through space as shown in Fig. 9. The law of expansion is^{2,3,6,26,27}

$$w^2 = w_0^2 \left[1 + \left(\frac{\lambda z}{\pi w_0^2} \right)^2 \right]. \quad (50)$$

Here the z is measured from the beam waist where the phase front is plane and the beam reaches its minimum radius w_0 . For $R(z)$ we have^{2,3,6,26,27}

$$R = z \left[1 + \left(\frac{\pi w_0^2}{\lambda z} \right)^2 \right]. \quad (51)$$

Dividing (50) by (51) we find

$$\frac{\pi w^2}{\lambda R} = \frac{\lambda z}{\pi w_0^2} \quad (52)$$

which we can use to rewrite the terms in the round brackets, and express w_0 and z in terms of w and R

$$w_0^2 = \frac{w^2}{1 + \left(\frac{\pi w^2}{\lambda R} \right)^2} \quad (53)$$

$$z = \frac{R}{1 + \left(\frac{\lambda R}{\pi w^2} \right)^2}. \quad (54)$$

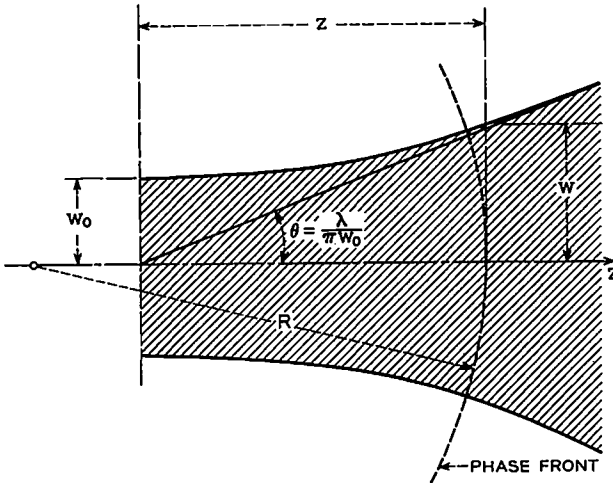

Fig. 9 — Contour of Gaussian beam of light.

4.2 Beam Transformation by a Lens

When a Gaussian beam passes through a lens a new beam waist is formed, and the parameters in the expansion laws are changed. Assume the light beam is propagating to the right. Before passing through the lens it has a beam waist a distance d_1 away from the lens with a beam radius w_1 as shown in Fig. 10. The lens produces another beam waist a distance d_2 away with a beam radius w_2 . The distances d_1 and d_2 are measured positive as shown in the figure (for a negative d_1 one has a virtual waist). In the following we will establish some relationships between beam parameters of the incoming beam (identified by the subscript 1) and the parameters of the transformed beam (subscript 2).

The far field angles²⁷ θ_1 and θ_2 of the two beams are computed from (50) as

$$\theta_1 = \lambda/\pi w_1 ; \quad \theta_2 = \lambda/\pi w_2 . \quad (55)$$

From these two angles follow immediately the beam radii w_{1f} and w_{2f} in the two focal planes of the lens where the image of the far field appears

$$w_{1f} = f\theta_2 = \lambda f/\pi w_2 \quad (56)$$

$$w_{2f} = f\theta_1 = \lambda f/\pi w_1 . \quad (57)$$

The beam radius in one of the focal planes is, of course, independent of the spacing between the lens and the beam waist of the other beam. It follows from (51) that the center of curvature of the far field phase front is in the beam waist. According to the imaging rules of Section II, corresponding centers of curvature are images of each other (where we take the phase fronts as reference surfaces). We therefore have to determine the image of a beam waist to find the curvature center of the phase front in the focal plane on the other side of the lens. The distance d_2' between the lens and the image of the waist w_2 follows from

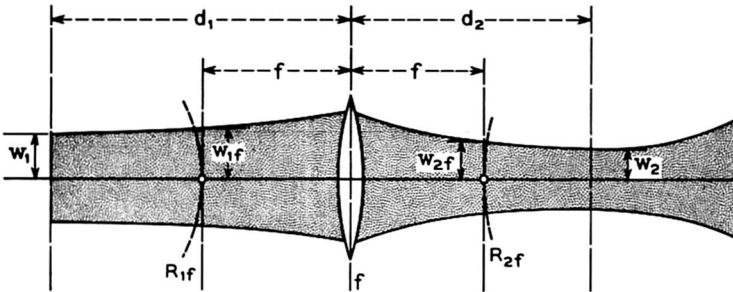

Fig. 10 — Gaussian beam transformed by a lens.

$$(1/d_2') + (1/d_2) = 1/f, \quad (58)$$

and the radius of curvature R_{1f} in the left focal plane is equal to the spacing between that image and the focal plane

$$R_{1f} = d_2' - f. \quad (59)$$

Combining (58) and (59) we have

$$R_{1f} = \frac{f^2}{d_2 - f} \quad (60)$$

and correspondingly

$$R_{2f} = \frac{f^2}{d_1 - f} \quad (61)$$

for the radius of curvature in the right focal plane. R_{1f} and R_{2f} are independent of the beam radii w_2 and w_1 , respectively, a fact that can be used for mode matching into confocal resonators.

To relate the beam waists we use (56) and (60) to write

$$\frac{\pi w_{1f}^2}{\lambda R_{1f}} = \frac{\lambda(d_2 - f)}{\pi w_2^2} \quad (62)$$

and similarly

$$\frac{\pi w_{2f}^2}{\lambda R_{2f}} = \frac{\lambda(d_1 - f)}{\pi w_1^2}. \quad (63)$$

To express w_2 in terms of w_1 and d_1 we insert (57) and (63) into (53) and find

$$\frac{1}{w_2^2} = \frac{1}{w_1^2} \left(1 - \frac{d_1}{f}\right)^2 + \frac{1}{f^2} \left(\frac{\pi w_1}{\lambda}\right)^2. \quad (64)$$

This relation, first given by Goubau,⁶ relates the beam radius of the waist of the transformed beam to the parameters of the incoming beam. A corresponding relation for the spacing d_2 between the lens and the beam waist w_2 is found by inserting (61) and (63) in (54). The result is

$$d_2 - f = (d_1 - f) \frac{f^2}{(d_1 - f)^2 + \left(\frac{\pi w_1}{\lambda}\right)^2}. \quad (65)$$

The above expressions were derived with the help of the imaging rules of Section II. As mentioned before, these rules apply not only to thin lenses but also to thick lenses and lens combinations. Therefore,

if d_1 and d_2 are measured from the principal planes the results given above are valid for the transformation of Gaussian beams by thick lenses.

4.3 Mode Matching

In experiments with optical modes one often wants to transform a beam with a given beam radius w_1 at the waist into another beam of waist radius w_2 . One wants to "match" the modes of one optical system (like a laser resonator) to the modes of another one (an optical transmission line for example). This can be done by selecting a suitable lens and by properly adjusting the waist spacings d_1 and d_2 , where we refer to Fig. 10. The proper spacings are given by the mode matching formulae⁷ derived below.

We combine (62) or (63) with (52) and obtain

$$\frac{d_1 - f}{d_2 - f} = \frac{w_1^2}{w_2^2}. \quad (66)$$

This is used to rewrite (64) in the form

$$\frac{1}{w_2^2} = \frac{1}{w_1^2 f^2} (d_1 - f)(d_2 - f) + \frac{1}{f^2} \left(\frac{\pi w_1}{\lambda} \right)^2. \quad (67)$$

Multiplying (67) by $w_2^2 f^2$ we arrive at

$$(d_1 - f)(d_2 - f) = f^2 - f_0^2 \quad (68)$$

where we have defined

$$f_0 = \pi(w_1 w_2 / \lambda). \quad (69)$$

To arrive at the mode-matching formulae we multiply or divide (68) by (66), extract the square root, and find

$$d_1 - f = \pm \frac{w_1}{w_2} \sqrt{f^2 - f_0^2} \quad (70)$$

or

$$d_2 - f = \pm \frac{w_2}{w_1} \sqrt{f^2 - f_0^2}. \quad (71)$$

As discussed in Ref. 7, one achieves mode matching by choosing a lens (or lens combination) with a focal length f that is larger than f_0 or equal to it. For a given lens there are generally two ways open to match the modes. One can choose either the plus sign in both (70) and

(71), or the minus sign. For $f = f_0$ there is only one set of proper spacings $d_1 = d_2 = f = f_0$.

4.4 Complex Beam Parameter — ABCD Law

In the foregoing we have used two parameters to characterize a Gaussian beam in a given beam cross section: the spot size or beam radius w , and the radius of phase front curvature R . We define now a more abstract complex beam parameter q

$$1/q = (1/R) - j(\lambda/\pi w^2). \quad (72)$$

The propagation and transformation laws for this beam parameter are particularly simple and allow one to trace Gaussian beams through more complicated optical structures. The old parameters R and w can, of course, be recovered from the real and imaginary parts of $1/q$. Note that we can regard the circle diagram of Collins¹¹ as plotted in the complex plane of the variable j/q , and the circle diagram of Li¹² as plotted in the complex plane of jq^* .

In terms of the complex beam parameter the laws of propagation (50) and (51) have the simple and compact form†

$$q = q_0 + z \quad (73)$$

as one easily verifies by inserting (50) and (51) into (72). Here

$$q_0 = j(\pi w_0^2/\lambda) \quad (74)$$

is the complex beam parameter at the beam waist. Because of the linearity of (73) the parameters q_1 and q_2 of two arbitrary beam cross sections are related by

$$q_2 = q_1 + d \quad (75)$$

where d is the distance between the two planes of interest measured positive in the direction of the optic axis.

The beam parameters q_1 and q_2 to the left and to the right of a lens are related by

$$1/q_2 = (1/q_1) - (1/f) \quad (76)$$

which simultaneously states the transformation of the phase fronts as in (1) or (2), and the fact that the beam radii (widths) are the same on both sides of the lens [compare (1)].

† Similar propagation laws for optical modes have been used independently by D. A. Kleinman, A. Ashkin, and G. D. Boyd in an analysis of second-harmonic generation in crystals and by G. A. Deschamps and P. E. Mast in their recent paper in Proc. Symp. Quasi-Optics, Polytechnic Inst. Brooklyn, 1964, p. 379.

The imaging law (6) applied to Gaussian beams takes the form

$$\frac{1}{q_2} = \frac{d_1^2}{d_2^2} \cdot \frac{1}{q_1} + \frac{1}{f} \frac{d_1}{d_2} \quad (77)$$

if written in terms of the complex parameters q_1 and q_2 of the beam in the object or image planes, respectively. Comparing with (7) and (8) one can also write this relation between the parameters of the object and the image as

$$\frac{1}{d_1 + q_1} + \frac{1}{d_2 - q_2} = \frac{1}{f}. \quad (78)$$

Using (75) and (76) one can easily determine how an incoming beam with the parameter q_1 at a distance d_1 from a lens is transformed. The parameter q_2 of the transformed beam at a distance d_2 from the lens is obtained as

$$q_2 = \frac{\left(1 - \frac{d_2}{f}\right) q_1 + \left(d_1 + d_2 - \frac{d_1 d_2}{f}\right)}{-\frac{q_1}{f} + \left(1 - \frac{d_1}{f}\right)}. \quad (79)$$

To establish a link to the transformation laws for the real parameters developed before, we multiply both sides of (79) with the denominator of the right side. Then we postulate that we have beam waists at d_1 and d_2 by putting $q_1 = j\pi w_1^2/\lambda$ and $q_2 = j\pi w_2^2/\lambda$. If we compare the real parts of the resulting expression, we obtain relation (68), and comparing the imaginary parts we find (66).

Let us now regard q_1 and q_2 as the beam parameters in the input and output planes of an optical system described by its ray ($ABCD$) matrix as in Section III. This system is also described by its focal length and its principal planes as calculated from (16), (17), and (18). To relate q_1 and q_2 we use (79) and put $d_1 = h_1$, and $d_2 = h_2$. Comparing with (19), (20), (21), and (22) we see that

$$q_2 = \frac{Aq_1 + B}{Cq_1 + D} \quad (80)$$

which we shall call the $ABCD$ law. The q parameters of the input and the output are related by this bilinear transformation. The $ABCD$ law says that the constants of this transformation are equal to the elements of the ray matrix. The ray matrices of several optical structures are given in Section III, and we shall use the $ABCD$ law to study the passage of Gaussian beams through some of these structures.

There appears to be a very close connection between Gaussian light

beams and the spherical waves of geometrical optics. In fact, all the important laws of this chapter are formally the same for a spherical wave with a radius of curvature q . One is therefore tempted to regard a Gaussian beam as a spherical wave with a complex radius of curvature. For the limit of infinitely small wavelengths the curvature radius becomes real and one has a spherical wave of geometrical optics.

The $ABCD$ law allows also a kind of "black box" approach to the study of optical modes. One can, for example, inquire about the mode parameters of a sequence of equal black boxes, i.e., optical structures characterized by their ray matrix elements A , B , C , and D . For a mode the beam parameter at the output of a black box is equal to the parameter at the input ($q_1 = q_2 = q$). From (80) follows a quadratic equation for the mode parameter q

$$Cq^2 + (D - A)q - B = 0. \quad (81)$$

The solution of this equation can be written as

$$\frac{1}{q} = \frac{D - A}{2B} \mp \frac{j}{2B} \sqrt{4 - (A + D)^2} \quad (82)$$

from which one can obtain the beam radius or spot size of the mode and the radius of curvature of its phase front.

4.5 Beam Transformation by a Telescope

In this chapter we shall study the passage of a Gaussian beam through a telescope consisting of two lenses of focal length f_1 and f_2 , respectively, spaced at a distance $d = f_1 + f_2 - \Delta d$. The "misadjustment" Δd is assumed small. The focal length and the location of the principal planes of the telescope are given in (27), (28), and (29). We consider an incoming beam with a beam radius w_1 at its waist, and the waist spaced at a distance s_1 from the first lens as shown in Fig. 11. We want to determine the location s_2 of the waist of the outgoing beam and its beam radius w_2 .

The distances of the waists to the corresponding principal planes are

$$d_1 = s_1 + h_1; \quad d_2 = s_2 + h_2. \quad (83)$$

From this we find with (24) and (27)

$$\frac{d_1}{f} - 1 = \frac{f_1}{f_2} + \frac{\Delta d}{f_2} \left(\frac{s_1}{f_1} - 1 \right). \quad (84)$$

Inserting this expression together with (27) in (64) we get for the beam

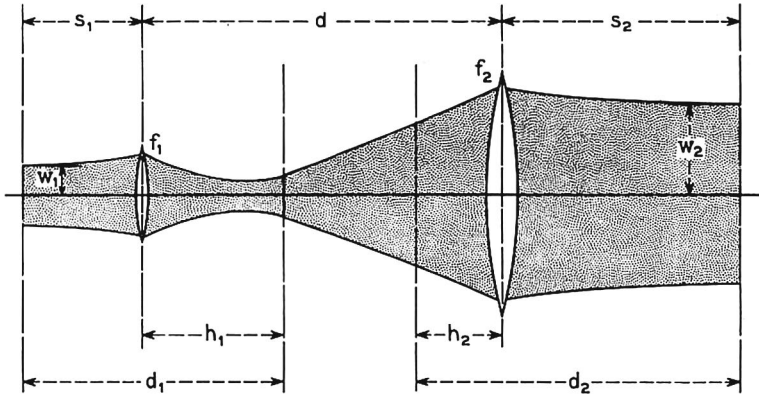

Fig. 11 — Gaussian beam passing through a telescope.

waist w_2

$$w_2 = w_1 \frac{f_2}{f_1} \left[1 + \frac{\Delta d}{f_1} \left(1 - \frac{s_1}{f_1} \right) \right] \quad (85)$$

which is correct to first order in Δd . We see that the ratio of the beam waists is more or less equal to the ratio of the focal lengths of the lenses. There is only a slight dependence on the position of the input beam waist for $\Delta d \neq 0$.

To determine the location of the output beam waist we use (84) and the corresponding expression for $(d_2/f) - 1$ to rearrange (68) as

$$\frac{s_1 - f_1}{f_1^2} + \frac{s_2 - f_2}{f_2^2} = -\frac{\Delta d}{f_1 f_2} \left[\left(\frac{s_1}{f_1} - 1 \right) \left(\frac{s_2}{f_2} - 1 \right) + \frac{1}{f_1 f_2} \left(\pi \frac{w_1 w_2}{\lambda} \right)^2 \right]. \quad (86)$$

Inserting (85) and expanding to first order in Δd this becomes

$$\frac{s_1 - f_1}{f_1^2} + \frac{s_2 - f_2}{f_2^2} = \frac{\Delta d}{f_1^4} \left[(s_1 - f_1)^2 - \left(\frac{\pi w_1^2}{\lambda} \right)^2 \right]. \quad (87)$$

For a well-adjusted telescope we have $\Delta d = 0$, and the distances between the beam waists and the focal planes of the corresponding lenses (i.e., $s_1 - f_1$ and $s_2 - f_2$) scale like the squares of the focal lengths of the two lenses. The signs in (87) indicate that for an input waist which lies to the left of the focal plane of the input lens one has an output beam waist to the left of the focal plane of the output lens, and conversely for an input waist to the right of the input focal plane.

4.6 Beam Transformation by a Sequence of Lenses

Consider now a sequence of lenses of equal focal length f spaced at a distance d as shown in Fig. 6. Immediately to the right of each lens an optical mode of this structure has a phase front with a radius of curvature of $-2f$ and a beam radius w_m given^{3,4,26} by

$$\frac{\lambda}{\pi w_m^2} = \frac{1}{2f} \sqrt{4 \frac{f}{d} - 1} = \frac{\sin \theta}{d} \quad (88)$$

where θ is defined in (34). To the right of each lens the complex beam parameter (72) of a mode is therefore

$$\frac{1}{q_m} = -\frac{1}{2f} - j \frac{\sin \theta}{d}. \quad (89)$$

Assume that a Gaussian beam is injected into the lens sequence, and call its complex beam parameter in the input plane q_1 . If $q_1 = q_m$, then we have launched a mode of the system, and the parameter of the beam to the right of every lens is q_m . For $q_1 \neq q_m$ we use the *ABCD* law (80) to compute the beam parameter q_2 to the right of the n th lens. The elements of the ray matrix of n sections of the lens sequence are given in (33), and we use them to apply the *ABCD* law. We have

$$q_2 = \frac{[\sin n\theta - \sin(n-1)\theta]q_1 + d \sin n\theta}{-\frac{1}{f} \sin n\theta \cdot q_1 + \left(1 - \frac{d}{f}\right) \sin n\theta - \sin(n-1)\theta}. \quad (90)$$

From (34) it follows that

$$\sin n\theta - \sin(n-1)\theta = (d/2f) \sin n\theta + \sin \theta \cos n\theta \quad (91)$$

which can be used together with (89) to rewrite (90) as

$$\frac{1}{q_2} - \frac{1}{q_m} = \frac{\sin \theta \cdot e^{jn\theta}}{\sin \theta \cdot e^{-jn\theta} + d \left(\frac{1}{q_1} - \frac{1}{q_m}\right) \sin n\theta} \left(\frac{1}{q_1} - \frac{1}{q_m}\right). \quad (92)$$

After some further rearranging this can be written in the form

$$\frac{1}{\frac{1}{q_2} - \frac{1}{q_m}} + \frac{1}{\frac{2}{q_m} + \frac{1}{f}} = \left[\frac{1}{\frac{1}{q_1} - \frac{1}{q_m}} + \frac{1}{\frac{2}{q_m} + \frac{1}{f}} \right] \exp(-2jn\theta). \quad (93)$$

For the case where the q parameter of the injected beam does not differ too much from the parameter q_m of a mode we can put

$$\Delta = (1/q_1) - (1/q_m) \quad (94)$$

and assume that Δ is small. Developing (92) in powers of Δ we obtain

$$\frac{1}{q_2} - \frac{1}{q_m} = \Delta \cdot e^{2jn\theta} - j\Delta^2 \frac{\pi w_m^2}{2\lambda} (e^{2jn\theta} - e^{4jn\theta}) + O(\Delta^3). \quad (95)$$

If we neglect all but the first-order term in (95) and compare the real and imaginary parts, we arrive at approximate formulae* for the output parameters R_2 and w_2 :

$$\begin{aligned} \frac{1}{R_2} + \frac{1}{2f} &= \left(\frac{1}{R_1} + \frac{1}{2f} \right) \cos 2n\theta + \frac{\lambda}{\pi} \left(\frac{1}{w_1^2} - \frac{1}{w_m^2} \right) \sin 2n\theta, \\ \frac{1}{w_2^2} - \frac{1}{w_m^2} &= -\frac{\pi}{\lambda} \left(\frac{1}{R_1} + \frac{1}{2f} \right) \sin 2n\theta + \left(\frac{1}{w_1^2} - \frac{1}{w_m^2} \right) \cos 2n\theta. \end{aligned} \quad (96)$$

Comparing these expressions with (33) we see that the beam radius w_2 varies in z direction with a period that is half the period with which a ray displacement varies. This fact has already been seen experimentally,⁷ and has also been noted for other optical structures.²⁸

The formulae (96) are valid for cases where the parameters w_1 and R_1 of the input beam do not differ much from the parameters of the mode of the lens sequence (i.e. for small Δ). For cases where this condition is not fulfilled we have to go back to (90). Using (72) we re-express the q parameters in terms of w_1 , R_1 , w_2 , and R_2 and compare the imaginary parts of $1/q_2$ as given by (90). After some algebra, where (91) is used to make simplifications, we obtain

$$\begin{aligned} \frac{w_2^2}{w_1^2} &= \frac{1}{2} \left[1 + \frac{w_m^4}{w_1^4} + \left(\frac{\pi w_m^2}{\lambda} \right)^2 \left(\frac{1}{R_1} + \frac{1}{2f} \right)^2 \right] \\ &+ \frac{1}{2} \left[1 - \frac{w_m^4}{w_1^4} - \left(\frac{\pi w_m^2}{\lambda} \right)^2 \left(\frac{1}{R_1} + \frac{1}{2f} \right)^2 \right] \cos 2n\theta \\ &+ \left(\frac{\pi w_m^2}{\lambda} \right) \left(\frac{1}{R_1} + \frac{1}{2f} \right) \sin 2n\theta. \end{aligned} \quad (97)$$

In this exact expression for w_2 we find the same periodicity in z direction as in (96). As n is varied w_2 goes through maximum values w_{\max} and minimum values w_{\min} . It is easy to show from (97) that

$$w_{\max} w_{\min} = w_m^2.$$

Note that w_{\max} and w_{\min} are the extrema of the envelope curve obtained for continuously variable n . The extremal values of w_2 actually occur at a lens only if the corresponding n is an integer.

* In a recent publication by J. Hirano and Y. Fukatsu in Proc. IEEE, 52, Nov., 1964, p. 1284, similar expressions were derived by means of a perturbation technique in which the real beam parameters were used directly.

An exact expression for R_2 is obtained by comparing the real parts of $1/q_2$ in (90) in a similar way.

4.7 Beam Transformation by a Lenslike Medium

The passage of Gaussian beams through a lenslike medium as described by (42) has been discussed by several investigators.^{19,28,29,30,31} We assume here for simplicity that $n_0 = 1$, or a refractive index given by

$$n = 1 - 2(r^2/b^2). \quad (98)$$

It is easy to show^{19,28,29,30,31} that for a Gaussian beam that is injected with a plane wave front and a beam radius w_0 given by

$$w_0^2 = \lambda b/2\pi \quad (99)$$

the wave front remains plane, and the beam radius remains constant as the wave propagates. These light beams are called the modes of the lenslike medium. If the beam is injected with a beam radius $w_1 \neq w_0$, the wave front and the beam radius will change as a function of z . This problem has been treated by Tien et al.²⁸ with the help of a differential equation, and by Marcatili²⁹ who expanded the field distribution of the input beam in terms of the modes of the lenslike medium. We will show here that one can get the desired results in a rather simple fashion by employing the *ABCD* law (80).

The elements of the ray matrix of a medium section of length z are given in (44). Using these together with (80) one computes for a beam with the complex parameter q_1 in the input plane a beam parameter

$$q_2 = \frac{q_1 \cos 2\frac{z}{b} + \frac{b}{2} \sin 2\frac{z}{b}}{-q_1 \frac{2}{b} \sin 2\frac{z}{b} + \cos 2\frac{z}{b}} \quad (100)$$

in the output plane a distance z away from the input. Assuming an input beam with a plane wave front and a beam radius w_1 we have

$$\frac{1}{q_1} = -j \frac{\lambda}{\pi w_1^2}. \quad (101)$$

Inserting this and (99) in (100) we obtain

$$\frac{1}{q_2} = -\frac{\lambda}{\pi w_0^2} \frac{\sin 2\frac{z}{b} + j \frac{w_0^2}{w_1^2} \cos 2\frac{z}{b}}{\cos 2\frac{z}{b} - j \frac{w_0^2}{w_1^2} \sin 2\frac{z}{b}}. \quad (102)$$

If we compare the imaginary parts in this expression we get

$$w_2^2 = w_1^2 \left(\cos^2 2\frac{z}{b} + \frac{w_0^4}{w_1^4} \sin^2 2\frac{z}{b} \right) \quad (103)$$

which agrees with the results of Refs. 28 and 29. A comparison of the real parts yields an expression for the curvature of the wave front.

V. RESONATORS WITH INTERNAL OPTICAL ELEMENTS

5.1 The Basic Resonator Parameters

A resonator consisting of two spherical mirrors spaced at a distance d is shown in Fig. 12. R_1 and R_2 are the radii of curvature of the two mirrors, measured positive as shown in the figure. The mirror diameters or widths are $2a_1$ and $2a_2$, respectively. The three basic parameters of such a resonator are^{10,22,33}

$$N = \frac{a_1 a_2}{\lambda d}, \quad (104)$$

$$G_1 = \frac{a_1}{a_2} \left(1 - \frac{d}{R_1} \right), \quad (105)$$

$$G_2 = \frac{a_2}{a_1} \left(1 - \frac{d}{R_2} \right). \quad (106)$$

Within the Fresnel diffraction theory of optical resonators these three

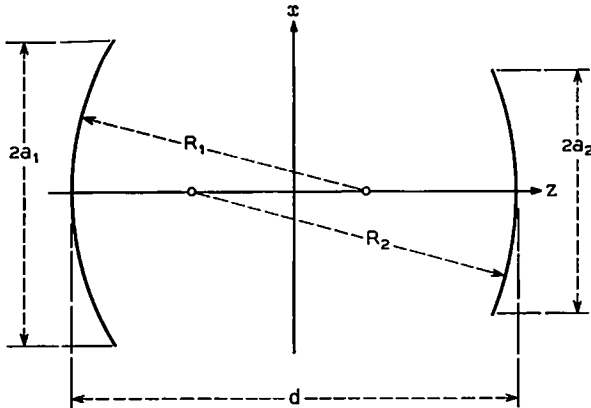

Fig. 12 — Empty spherical mirror resonator.

parameters determine completely the diffraction losses, the resonant frequencies, and the mode patterns of the resonator.³²

In the following we will show that resonators in which lenses or similar optical structures are inserted between the resonator mirrors are equivalent to an empty resonator of the type shown in Fig. 12. By equivalent resonators we mean here resonators with the same diffraction losses, the same mode patterns except for a scaling factor, and the same resonant conditions. To specify an empty resonator equivalent to a resonator with internal optical elements we will compute its parameters N , G_1 , and G_2 .

5.2 Resonators with an Internal Lens

A resonator with an internal lens is shown in Fig. 13. A lens of focal length f is spaced a distance d_1 away from the left mirror and d_2 away from the right mirror. As before we call the radii of curvature of the two mirrors R_1 and R_2 , and their diameters $2a_1$ and $2a_2$ as shown. The internal lens is assumed to be so large that no additional aperture diffraction effects are introduced.

Suppose now that we know the modes of the resonator. We can apply the imaging rules of Section II and choose the mirror surface of the right mirror, say, as reference surface. The image of the mode pattern on this mirror appears a distance

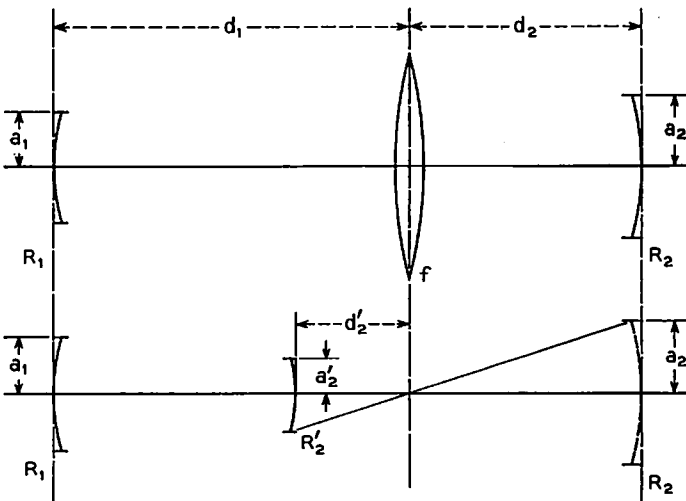

Fig. 13 — Resonator with internal lens and equivalent empty resonator.

$$d_2' = \frac{fd_2}{d_2 - f} \quad (107)$$

away from the lens as shown in the figure. The field of the wave reflected from the mirror is zero outside the mirror aperture a_2 . The field of the corresponding image is therefore zero outside an aperture a_2' given by the magnification

$$\frac{a_2}{a_2'} = -\frac{d_2}{d_2'} = 1 - \frac{d_2}{f}. \quad (108)$$

The image is a scaled reproduction of the mode pattern on the mirror which is exact in amplitude and phase if a spherical reference surface is chosen. The correct curvature of this surface is found in accordance with (6) and (8) by imaging the center of curvature of the mirror on the right.

Consider now a mirror of diameter $2a_2'$ placed at the location of the image a distance

$$d = d_1 - d_2' \quad (109)$$

away from the original left mirror as shown in the lower part of Fig. 13. The mirror curvature is chosen to be the same as the curvature of the reference surface for the image. This mirror may be called the image-mirror of the original mirror on the right. Apart from a phase difference of $2k(d_2 + d_2')$ it reflects a wave coming in from the left in exactly the same way as the original mirror combined with the lens. The incoming wave produces the same (magnified) complex amplitude distribution or field pattern on the image mirror as on the original mirror on the right. The outgoing wave reflected by the image mirror has a field pattern at d_2' that is identical to the field pattern at d_2' of the outgoing wave reflected by the combination of the original mirror and the lens. The field patterns of the two outgoing waves are thus also identical in any other beam cross section, and in particular across the left mirror. Therefore the modes of the empty resonator formed by the image of the right mirror and the original left mirror as shown in the figure are equivalent to the original resonator with the internal lens. The mode patterns on the left mirror are identical in both cases, and the mode patterns of the corresponding mirrors on the right are scales of each other. The diffraction losses of the two systems are also the same, and there is only a small difference in the corresponding resonant conditions due to the difference in phase shift of $k(d_2 + d_2')$ per transit.

The basic parameters of the equivalent empty resonator are easily

obtained. According to (104) we have a Fresnel number of

$$N = a_1 a_2' / \lambda d \quad (110)$$

and with (105)

$$G_1 = \frac{a_1}{a_2'} \left(1 - \frac{d}{R_1} \right). \quad (111)$$

With (107), (108), and (109) these expressions can be written in terms of the dimensions of the resonator with the internal lens. One obtains

$$N = \frac{a_1 a_2}{\lambda \left(d_1 + d_2 - \frac{d_1 d_2}{f} \right)}, \quad (112)$$

and

$$G_1 = \frac{a_1}{a_2} \left\{ 1 - \frac{d_2}{f} - \frac{1}{R_1} \left(d_1 + d_2 - \frac{d_1 d_2}{f} \right) \right\}. \quad (113)$$

By interchanging subscripts one gets

$$G_2 = \frac{a_2}{a_1} \left\{ 1 - \frac{d_1}{f} - \frac{1}{R_2} \left(d_1 + d_2 - \frac{d_1 d_2}{f} \right) \right\}. \quad (114)$$

These three parameters determine the properties of the modes of the internal lens resonator. In the above expression one notes the appearance of the term

$$d_0 = d_1 + d_2 - (d_1 d_2 / f) \quad (115)$$

which one might call the effective distance between the mirrors. It is modified by the presence of the lens.

In Refs. 4 and 32 approximate expressions are given for the resonant condition and the beam radii (spot size) of the fundamental mode at the mirrors of an empty resonator that is stable. Recall that for a stable resonator there holds

$$0 \leq G_1 G_2 \leq 1. \quad (116)$$

We can apply these formulae to our equivalent resonator and obtain by imaging the corresponding expressions for the resonant wavelength λ and the beam radii w_1 and w_2 on the mirrors of our resonator with an internal lens. Using the parameters discussed above we get

$$\frac{2(d_1 + d_2)}{\lambda} = q + \frac{1}{\pi} (m + n + 1) \cos^{-1} \sqrt{G_1 G_2} \quad (117)$$

where q is the longitudinal mode number, and m and n are the transverse mode numbers. The sign of the square root should be chosen equal to the sign of G_1 (or G_2). For the beam radii we get

$$w_1 w_2 = \frac{\lambda d_0}{\pi} (1 - G_1 G_2)^{-\frac{1}{2}}, \quad (118)$$

and

$$\frac{w_1}{w_2} = \frac{a_1}{a_2} \left(\frac{G_2}{G_1} \right)^{\frac{1}{2}}. \quad (119)$$

The image mirror discussed above can also be obtained from the concept of a "thick mirror." A thick mirror¹³ is a combination of a spherical mirror and a lens. The optical characteristics of this combination are represented by a combined focal length and a principal plane.¹³ A mirror of this focal length located at the principal plane is equivalent to the thick mirror combination. This equivalent mirror is the same as our image mirror.

The equivalence of the empty resonator and the internal lens resonator can also be shown by using the Fresnel diffraction formula in the manner of Appendix A. One obtains integral equations for the modes of an internal lens resonator. After performing the integration over the lens plane which involves infinite Fresnel integrals, the equivalence to the empty resonator is easily seen.

For cases where the effective distance d_0 as given by (115) is very small, ray angles of interest become rather large and the theory of Fresnel diffraction is no longer expected to apply. We have to exclude these cases from our considerations.

Our discussion includes internal lens resonators with flat mirrors as shown in Fig. 14. The basic parameters of this resonator type can be obtained from (112), (113), and (114) by putting $R_1 = R_2 = \infty$. Burch and Toraldo di Francia⁸ have discussed the confocal system of this resonator family where $G_1 = G_2 = 0$. The transmission line dual of an internal lens resonator with flat mirrors is also shown in Fig. 14. It is a sequence of lenses and irises spaced as shown. In this sequence the lenses are large and the irises inserted between them control the modes of the system. For a symmetric system of this kind where $d_1 = d_2 = d$ and $a_1 = a_2 = a$ the above expressions simplify, and we have

$$G_1 = G_2 = 1 - (d/f), \quad (120)$$

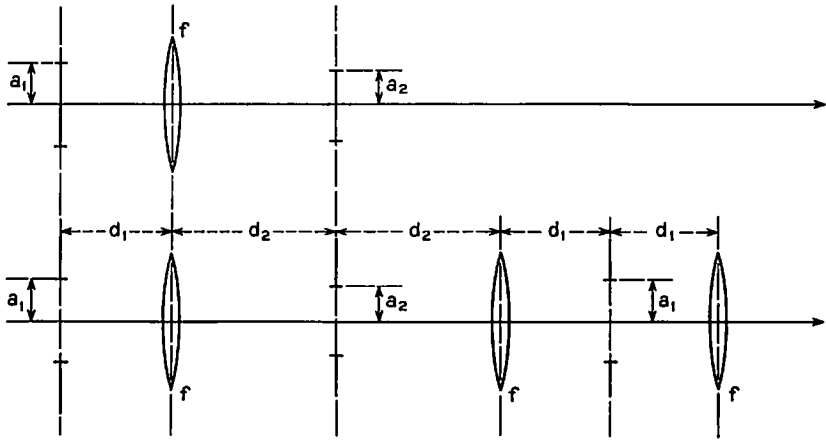

Fig. 14 — Internal lens resonator with flat mirrors and its transmission line dual, a sequence of lenses with irises placed between the lenses.

and a Fresnel number of

$$N = \frac{a^2}{\lambda d \left(2 - \frac{d}{f} \right)}. \quad (121)$$

5.3 Resonators with an Internal Optical System

As discussed before, the imaging rules of Section II apply not only to thin lenses but to any optical system that can be characterized by a focal length and by principal planes. The expressions derived above for internal lens resonators can therefore be applied also to spherical mirror resonators with an internal optical system. All one has to do is to interpret f as the focal length of the system and put

$$d_1 = h_1; \quad d_2 = h_2 \quad (122)$$

where h_1 and h_2 measure the distances between the two principal planes and the corresponding mirrors.

We can also characterize the internal optical system by its $ABCD$ or ray matrix as in (9). Inserting (122) in (112), (113), and (114) we compare the resulting expressions with (19) through (22). We note immediately that the three basic resonator parameters can be written in terms of the elements of the ray matrix in the form

$$N = \frac{a_1 a_2}{\lambda B}, \quad (123)$$

$$G_1 = \frac{a_1}{a_2} \left(A - \frac{B}{R_1} \right), \quad (124)$$

$$G_2 = \frac{a_2}{a_1} \left(D - \frac{B}{R_2} \right). \quad (125)$$

5.4 Internal Lenslike Medium — Guiding Medium with Apertures

In this section we consider a spherical mirror resonator with a lenslike medium inserted between the resonator mirrors. The optical properties of a lenslike medium have been discussed in Sections 3.4 and 4.7. The refractive index of this medium changes with the square of the distance from the optic axis and is described by (98) if we assume $n_0 = 1$. The degree of this index variation is measured by the parameter b . As shown in Fig. 15, we assume that the medium fills the space between the resonator mirrors which are spaced at a distance l . The mirror diameters are $2a_1$ and $2a_2$, respectively, and the corresponding radii of curvature are R_1 and R_2 .

The three basic resonator parameters which describe the modal properties of this resonator with an internal lenslike medium are easily computed by using the results obtained before. The elements of the ray matrix for a medium section of length l are given in (44). Inserting these in (123), (124), and (125) we obtain for the Fresnel number of the system

$$N = \frac{2a_1a_2}{\lambda b \sin 2\frac{l}{b}}, \quad (126)$$

and for the G parameters

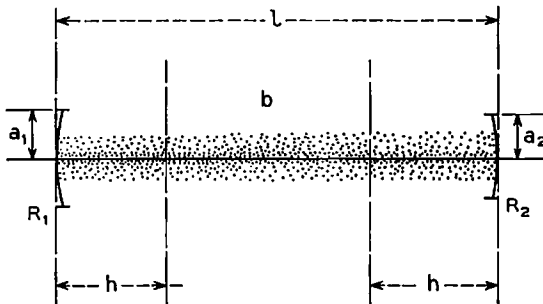

Fig. 15 — Resonator with an internal lenslike medium.

$$G_1 = \frac{a_1}{a_2} \left(\cos 2 \frac{l}{b} - \frac{b}{2R_1} \sin 2 \frac{l}{b} \right), \quad (127)$$

$$G_2 = \frac{a_2}{a_1} \left(\cos 2 \frac{l}{b} - \frac{b}{2R_2} \sin 2 \frac{l}{b} \right). \quad (128)$$

A special case of the above system is shown in Fig. 16, where the mirrors are flat, i.e., $R_1 = R_2 = \infty$. The transmission line dual of this resonator is also shown in the figure. It is the interesting case of a lenslike medium or a gas lens with periodically spaced irises as shown. For irises of equal diameter ($a_1 = a_2 = a$) the above expressions simplify, and we obtain for the Fresnel number of the system

$$N = \frac{2a^2}{\lambda b \sin 2 \frac{l}{b}}, \quad (129)$$

and

$$G_1 = G_2 = \cos 2 \frac{l}{b}. \quad (130)$$

This system is confocal for $l = (\pi/4)b$. When the value of $2l/b$ approaches a multiple of π , N gets very large and we have a case where the effective distance between the mirrors is very small [compare (115)]. As discussed before, the theory of Fresnel diffraction is no longer expected to apply under these circumstances.

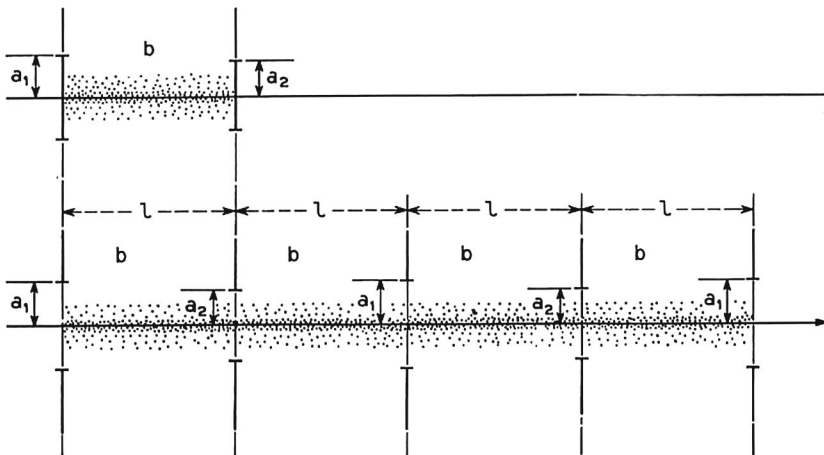

Fig. 16 — Resonator with flat mirrors and an internal lenslike medium, and its transmission line dual, a gas lens with periodically spaced irises.

In high-gain lasers the parameter l/b can become rather large for certain frequencies.²¹ For frequencies where the laser medium is focusing we have $b^2 > 0$, while for frequencies where the medium is defocusing $b^2 < 0$ and b is imaginary. It is interesting to study the stability⁴ of a resonator with an internal lenslike medium allowing for positive and negative values of b^2 . For simplicity we assume that the radii of curvature of the two resonator mirrors are equal and put $R_1 = R_2 = 2f$. With (127) and (128) we obtain

$$G_1 G_2 = G^2 = \left(\cos 2 \frac{l}{b} - \frac{b}{4f} \sin 2 \frac{l}{b} \right)^2 \tag{131}$$

and write the stability condition (116) in the form

$$-1 \leq G \leq 1. \tag{132}$$

One can plot a stability diagram in which each resonator with given parameters l, f , and b is represented by a point. Such a diagram is shown in Fig. 17, where l/f is plotted as ordinate and l/b and jl/b are plotted as abscissae. Resonators with $b^2 > 0$ are represented by points to the

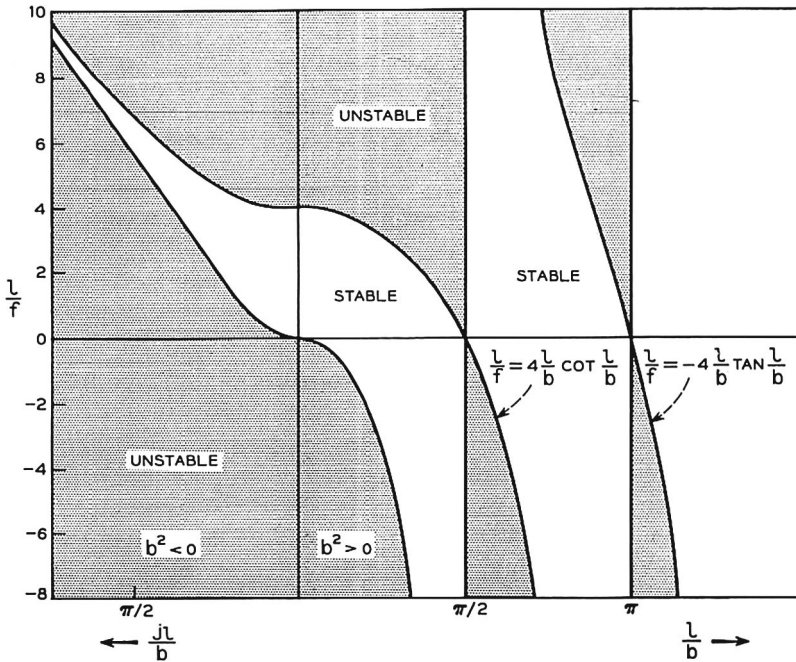

Fig. 17 — Stability diagram for a resonator with an internal lenslike medium.

right of the l/f axis, and resonators with $b^2 < 0$ are represented by points to the left. Points in the shaded regions correspond to unstable resonators, and resonators represented by points in the unshaded regions are stable. The boundaries between the stable and unstable regions follow from (131) and (132). They are described by the equations

$$\frac{l}{b} = \nu \frac{\pi}{2}, \quad \nu \text{ integer}, \quad (133)$$

$$\frac{l}{f} = 4 \frac{l}{b} \cot \frac{l}{b}, \quad (134)$$

$$\frac{l}{f} = -4 \frac{l}{b} \tan \frac{l}{b}. \quad (135)$$

For $b^2 < 0$, where b is imaginary, the trigonometric functions of (134) and (135) become hyperbolic functions as in (48) and (49). For $b^2 > 0$ one gets periodically stable and unstable regions as l/b is increased.

We have not discussed in detail cases where the lenslike medium occupies only a part of the space between the resonator mirrors. However, one can compute easily the basic parameters for resonators of this kind with the help of the matrix elements of (44), and the formulae (123), (124), and (125).

5.5 Resonators with One Very Large Mirror

Let us return to the case of an empty resonator. In some practical arrangements the diameter of one of the two mirrors, say $2a_2$, is so large that diffraction by its aperture can be neglected. The resonator modes are then more or less controlled by the aperture a_1 of the other mirror. This statement is not true for resonators of the degenerate confocal type where the diffraction losses at each mirror are equal⁴ for any aperture ratio a_2/a_1 . We exclude resonators of this type from our present discussion.

The properties of the resonator modes are generally determined by the three basic parameters given in (104), (105), and (106). But for an infinitely large a_2 the Fresnel number N and the parameter G_2 become infinitely large, and $G_1 = 0$. The resonator parameters are now quite meaningless. It is, however, possible to construct an equivalent resonator with parameters of finite value, as we will show below.

Consider Fig. 18. An empty resonator with one mirror of large diameter is shown schematically at the top. Below it we have drawn its transmission line dual. It consists of a sequence of lenses where an apertured lens

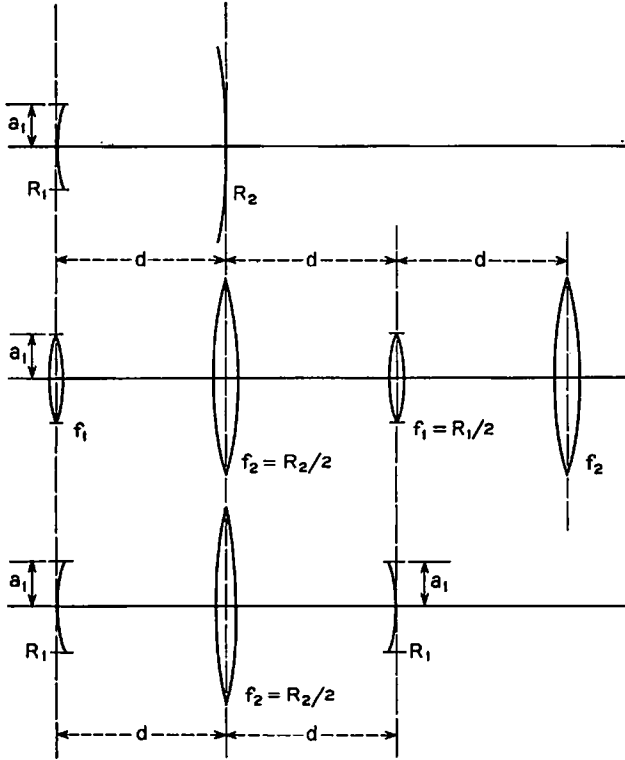

Fig. 18 — Empty resonator with one very large mirror, its transmission line dual, and its equivalent internal lens resonator.

follows an unapertured lens of large diameter. But this transmission line is also the dual of the resonator shown at the bottom of the figure. This is a resonator formed by apertured mirrors of finite diameter $2a_1$ with an internal lens of focal length $f = R_2/2$. The lens is unapertured. Internal lens resonators of this type have been considered before. We can compute the Fresnel number of this system from (112) and obtain

$$N = \frac{a_1^2}{2\lambda d \left(1 - \frac{d}{R_2}\right)}. \quad (136)$$

Equations (113) and (114) are used to calculate the G parameters with the result

$$G_1 = G_2 = 1 - 2d \left(\frac{1}{R_1} + \frac{1}{R_2} - \frac{d}{R_1 R_2} \right). \quad (137)$$

These parameters determine the properties of the modes of the internal lens resonator shown in Fig. 18. The mode patterns at the apertured mirrors of this resonator are, of course, equal to the mode pattern at the apertured mirror of the empty resonator. The one-trip diffraction loss of a mode of the internal lens resonator is equal to the return-trip diffraction loss of an empty resonator mode, as there are no diffraction losses at the infinitely large mirror.

For the special case where the large mirror is flat ($R_2 = \infty$) the above discussed equivalences are well known. They follow from symmetry considerations.

VI. ACKNOWLEDGMENTS

Stimulating discussions with E. I. Gordon, J. P. Gordon, R. Kompfner, T. Li, and P. K. Tien in various phases of this work are gratefully acknowledged.

APPENDIX A

Imaging for Fresnel Diffraction

The purpose of this appendix is to show how the imaging relation (6) of the main text is derived within the formalism of scalar Fresnel diffraction theory. Assume a light wave traveling in z direction and refer to Fig. 19. Call the object field $E_1(x_1, y_1)$ and the image field $E_2(x_2, y_2)$. The distances d_1 and d_2 between the lens and the object and image planes, respectively, are related by

$$(1/d_1) + (1/d_2) = 1/f. \quad (138)$$

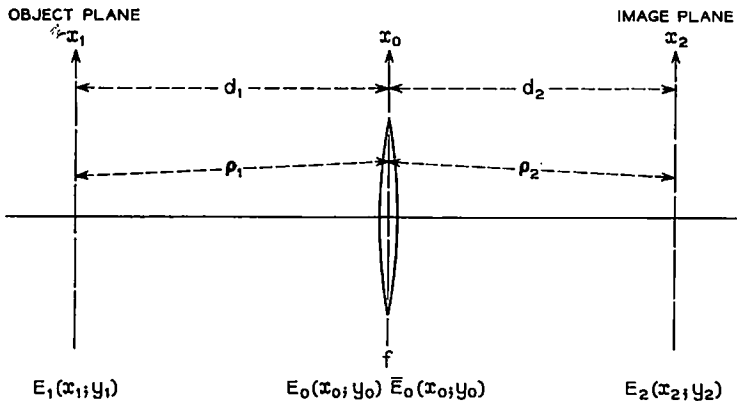

Fig. 19 — Dimensions of interest for Fresnel diffraction theory of imaging.

The field immediately to the left of the lens is denoted $E_0(x_0, y_0)$ and the field to the right of the lens is $\bar{E}_0(x_0, y_0)$. According to (1) of the main text we have for a large, ideal lens

$$\bar{E}_0 = E_0 \exp\left(-jk \frac{x_0^2 + y_0^2}{2f}\right) \quad (139)$$

where $k = 2\pi/\lambda$ is the propagation constant in the medium. With the help of the Fresnel diffraction formula the fields E_0 and E_2 can be expressed as

$$E_0 = \frac{jk}{2\pi d_1} \int_{A_1} dx_1 dy_1 E_1 \exp(-jk\rho_1) \quad (140)$$

and

$$E_2 = \frac{jk}{2\pi d_2} \int_{-\infty}^{+\infty} dx_0 dy_0 \bar{E}_0 \exp(-jk\rho_2) \quad (141)$$

where

$$\rho_1 = d_1 + \frac{1}{2d_1} (x_1 - x_0)^2 + \frac{1}{2d_1} (y_1 - y_0)^2 \quad (142)$$

and

$$\rho_2 = d_2 + \frac{1}{2d_2} (x_2 - x_0)^2 + \frac{1}{2d_2} (y_2 - y_0)^2. \quad (143)$$

The integration in (140) is performed over the aperture area A_1 of the object field, and the integration limits in (141) are extended to infinity with the assumption that the lens is so large that no additional aperture diffraction effects are introduced.

Combining (139), (140), and (141) we obtain by interchanging the order of integration

$$E_2 = -\frac{k^2}{4\pi^2 d_1 d_2} \int_{A_1} dx_1 dy_1 E_1 \int_{-\infty}^{+\infty} dx_0 dy_0 \cdot \exp\left[-jk\left(\rho_1 + \rho_2 + \frac{r_0^2}{2f}\right)\right] \quad (144)$$

where

$$r_0^2 = x_0^2 + y_0^2. \quad (145)$$

Now the expressions (142) and (143) for ρ_1 and ρ_2 are inserted. One finds that in the exponential the terms proportional to r_0^2 cancel because of (138). The integration with respect to x_0 and y_0 can be performed by noting that

$$\int_{-\infty}^{+\infty} dx_0 \exp \left[jkx_0 \left(\frac{x_1}{d_1} + \frac{x_2}{d_2} \right) \right] = 2\pi\delta \left(k \left[\frac{x_1}{d_1} + \frac{x_2}{d_2} \right] \right) \quad (146)$$

where δ is the Dirac delta function.³⁴ With this (144) becomes

$$\begin{aligned} E_2 = & -\frac{k^2}{d_1 d_2} \exp \left[-jk \left(d_1 + d_2 + \frac{r_2^2}{2d_2} \right) \right] \\ & \cdot \int_{A_1} dx_1 dy_1 E_1 \exp \left(-jk \frac{r_1^2}{2d_1} \right) \\ & \cdot \delta \left(k \left[\frac{x_1}{d_1} + \frac{x_2}{d_2} \right] \right) \cdot \delta \left(k \left[\frac{y_1}{d_1} + \frac{y_2}{d_2} \right] \right). \end{aligned} \quad (147)$$

This simplifies immediately with the help of the formalism of the delta function³⁴ to

$$\begin{aligned} E_2(x_2, y_2) = & -\frac{d_1}{d_2} E_1 \left(-\frac{d_1}{d_2} x_2, -\frac{d_1}{d_2} y_2 \right) \\ & \cdot \exp \left[-jk \left(d_1 + d_2 + \frac{r_2^2}{2d_2} \left(1 + \frac{d_1}{d_2} \right) \right) \right]. \end{aligned} \quad (148)$$

Multiplying (138) by d_1/d_2 one finds that

$$\frac{1}{d_2} \left(1 + \frac{d_1}{d_2} \right) = \frac{1}{f} \frac{d_1}{d_2} \quad (149)$$

which is used to write (148) in the form of (6) of the main text.

APPENDIX B

Principle of Equal Optical Path Leading to Additional Phase Shift in Image Plane

The process of imaging the field distribution in the object plane into the image plane can be understood in terms of the rays leaving each point (say P_1) in the object plane at various angles as shown in Fig. 20. All rays originating from P_1 are collected at a corresponding point P_2 in the image plane. A form of the principle of equal optical path³⁵ says that the optical path lengths from P_1 to P_2 are the same for all rays regardless of initial slope.

To obtain an image which is an exact reproduction of the original amplitude and phase distribution it would be necessary for the various optical paths which connect corresponding points, say P_1 and P_2 or Q_1 and Q_2 , to be equally long for all points regardless of their distance from the optic axis. That these path lengths are not the same for all

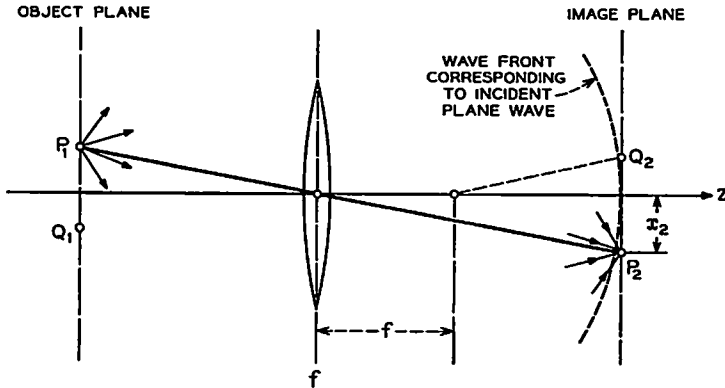

Fig. 20 — Rays emerging from a point of the object collected at the image.

points but increase with increasing distance between the imaged point and the optic axis can be seen from the simple example of an ideal plane wave coming in from the left. This case furnishes an expression for the path length difference as a function of the distance between the imaged point and the axis. As the path length is independent of the field distribution imaged, this expression is valid for the general case. To derive it we recall that an ideal plane wave is transformed by an ideal lens into an ideal spherical wave with the focal point of the lens as its center. The rays connecting points which lie on corresponding wave fronts are equally long for all points on the wave front.³⁵ Therefore all path lengths measured from the object plane to the spherical wave front which touches the image plane are equal. Paraxial rays (which are practically parallel to the optic axis) need an additional length equal to $r_2^2/2f$ to reach a point (P_2) in the image plane which is a distance r_2 away from the axis. This additional ray length accounts for the additional phase shift given in (6) in the main text.

REFERENCES

1. Fox, A. G., and Li, Tingye, Resonant Modes in a Maser Interferometer, B.S.T.J., 40, March, 1961, p. 453; Proc. IRE, 48, 1960, p. 1904.
2. Goubau, G., and Schwering, F., On the Guided Propagation of Electromagnetic Wave Beams, Trans. IRE, AP-9, May, 1961, p. 248.
3. Boyd, G. D., and Gordon, J. P., Confocal Multimode Resonator for Millimeter Through Optical Wavelength Masers, B.S.T.J., 40, March, 1961, p. 489.
4. Boyd, G. D., and Kogelnik, H., Generalized Confocal Resonator Theory, B.S.T.J., 41, July, 1962, p. 1347.
5. Fox, A. G., and Li, Tingye, Modes in a Maser Interferometer with Curved and Tilted Mirrors, Proc. IEEE, 51, Jan., 1963, p. 80.
6. Goubau, G., Optical Relations for Coherent Wave Beams, in *Electromagnetic Theory and Antennas*, ed. Jordan, E. C., Pergamon Press, 1963, p. 907.
7. Kogelnik, H., Matching of Optical Modes, B.S.T.J., 42, Jan., 1964, p. 334.

8. Burch, J. M., Design of Resonators, p. 1187 in *Quantum Electronics III*, ed. Grivet, P., and Bloembergen, N., Columbia University Press, New York, 1964; Toraldo di Francia, G., On the Theory of Optical Resonators, Proc. Symp. Optical Masers, New York, 1963, p. 157, Polytechnic Press, Brooklyn, New York.
9. Kogelnik, H., and Yariv, A., Considerations of Noise and Schemes for Its Reduction in Laser Amplifiers, Proc. IEEE, *52*, Feb., 1964, p. 165.
10. Gloge, D., Analysis of Fabry-Perot Laser-Resonators by Means of Scattering Matrices, Arch. El. Ü., *18*, March, 1964, p. 197.
11. Collins, S. A., Analysis of Optical Resonators Involving Focusing Elements, Appl. Opt., *3*, Nov., 1964, p. 1263.
12. Li, T., Dual Forms of the Gaussian Beam Chart, Appl. Opt., *3*, Nov., 1964, p. 1315.
13. Jenkins, F. A., and White, H. E., *Fundamentals of Optics*, 3rd ed., McGraw-Hill Book Company, New York, 1957, p. 89.
14. Born, M., and Wolf, E., *Principles of Optics*, Pergamon Press, New York, 1959, p. 420.
15. Pierce, J. R., *Theory and Design of Electron Beams*, D. Van Nostrand Company, Inc., New York, 1954, p. 194.
16. Herriott, D. R., Kogelnik, H., and Kompfner, R., Off-Axis Paths in Spherical Mirror Interferometers, Appl. Opt., *3*, April, 1964, p. 523.
17. Bertolotti, M., Matrix Representation of Geometrical Properties of Laser Cavities, Nuovo Cimento, June, 1964, p. 1242; O'Neill, E. L., *Introduction to Statistical Optics*, Addison-Wesley Publ. Co., Reading, Mass., 1963; Brouwer, W., *Matrix Methods in Optical Instrument Design*, Benjamin, New York, 1964.
18. Richards, P. I., *Manual of Mathematical Physics*, Pergamon Press, London, 1959, p. 312.
19. Tonks, L., Filamentary Standing-Wave Pattern in a Solid-State Maser, J. Appl. Phys., June, 1962, p. 1980.
20. Gudzenko, L. I., Concentration of a Light Wave in a Weakly Inhomogeneous Dielectric, J. Exp. Theor. Phys. (USSR), *44*, April, 1963, p. 1298; Sov. Phys. JETP, *17*, Oct., 1963, p. 875.
21. Kompfner, R., Talk at the Electron Device Research Conference, Salt Lake City, Utah, 1963.
22. Berreman, D. W., A Lens or Light Guide Using Convectively Distorted Thermal Gradients in Gases, B.S.T.J., *43*, July, 1964, p. 1469; A Gas Lens Using Unlike, Counter-Flowing Gases, B.S.T.J., *43*, July, 1964, p. 1476.
23. Marcuse, D., and Miller, S. E., Analysis of a Tubular Gas Lens, B.S.T.J., *43*, July, 1964, p. 1759.
24. Beck, A. C., Thermal Gas Lens Measurements, B.S.T.J., *43*, July, 1964, p. 1818; Gas Mixture Lens Measurements, B.S.T.J., *43*, July, 1964, p. 1821.
25. Born and Wolf, op. cit., p. 121.
26. Kogelnik, H., Modes in Optical Resonators; in *Advances in Lasers*, ed. Levine, A. K., Dekker Publishers, New York.
27. Yariv, A., and Gordon, J. P., The Laser, Proc. IEEE, *51*, Jan., 1963, p. 4.
28. Tien, P. K., Gordon, J. P., and Whinnery, J. R., Focusing of a Light Beam of Hermite-Gaussian Distribution in Continuous and Periodic Lenslike Media, to be published in Proc. IEEE.
29. Marcatili, E. A. J., Modes in a Sequence of Thick Astigmatic Lens-Like Focusers, B.S.T.J., *43*, November, 1964, p. 2887.
30. Gloge, D., Focusing of Coherent Light Rays in a Space Dependent Dielectric; Arch. El. Ü., *18*, July, 1964, p. 451.
31. Pierce, J. R., unpublished work.
32. Gordon, J. P., and Kogelnik, H., Equivalence Relations among Spherical Mirror Optical Resonators; B.S.T.J., *43*, November, 1964, p. 2873.
33. Streifer, W., and Gamo, H., On the Schmidt Expansion for Optical Resonator Modes, Proc. Symp. on Quasi-Optics, Polytechnic Inst. of Brooklyn, June, 1964.
34. Born and Wolf, op. cit., p. 752.
35. Born and Wolf, op. cit., p. 126.