

NAZI INTERNATIONAL

The Nazis' Postwar Plan to
Control Finance, Conflict,
Physics and Space



JOSEPH P. FARRELL

Author of
Reich of the Black Sun
The S.S. Brotherhood of the Bell
Secrets of the Unified Field

NAZI INTERNATIONAL

**The Nazis' Postwar Plan to
Control Finance, Conflict,
Physics and Space**



JOSEPH P. FARRELL

Author of
Reich of the Black Sun
The S.S. Brotherhood of the Bell
Secrets of the Unified Field

Other Books by Joseph P. Farrell:

Reich of the Black Sun
The S.S. Brotherhood of the Bell
Secrets of the Unified Field
The Cosmic War
The Giza Death Star
The Giza Death Star Deployed
The Giza Death Star Destroyed

NAZI INTERNATIONAL

Joseph P. Farrell



Adventures Unlimited Press

Nazi International

Copyright 2008
by Joseph P. Farrell

ISBN 10: 1-931882-93-2
ISBN 13: 978-1-931882-93-4

All Rights Reserved

Published by:
Adventures Unlimited Press
One Adventure Place
Kempton, Illinois 60946 USA
auphq@frontiernet.net

www.adventuresunlimitedpress.com

10 9 8 7 6 5 4 3 2 1

NAZI INTERNATIONAL

**The Nazis' Postwar Plan to
Control the Worlds of Science,
Finance, Space, and Conflict**

For
TSF, RCH,
And all who have
encouraged along the way

Acknowledgements

I wish to express my thanks to the many fine researchers whose material have contributed to this book, not the least of whom is Jim Marrs, for so graciously allowing me a first glance of his latest book *The Rise of the Fourth Reich* before it hit the bookstores. To Peter Levenda, Henry Stevens, Nick Cook, Igor Witkowski, Carter Hydrick and all those others whose superb and disturbing research contributed so much not only to my previous works on Nazi secret weapons, but whose thinking formed the basis of much of the new material and analysis I present here: many thanks. While the analysis is my own, each of these other researchers contributed many significant pieces to the puzzle.

A very special word of thanks is due to Harry Cooper of "Sharkhunters International." Mr. Cooper contacted me as this book was beginning to form, and offered the considerable investigative services of Sharkhunters, an international group of veterans of World War Two from all sides of the war. Mr. Cooper's unique insights, pictures, and comments are presented here in the hopes that this organization and its historical research will come to the attention of a wider audience. Its unique perspective and the vital detailed information it provided can literally not be found anywhere else! The perspective of these veterans plus Mr. Cooper's own highly illuminating expeditions to Argentina – not to mention his kindness in allowing me to present some of his pictures here – are truly and greatly appreciated.

Special thanks also to Mr. George Paxinos who kindly researched many hard-to-obtain books for me in European libraries, including the science fiction novels of Austrian Neo-Nazi Wilhelm Landig, works crucial for an insight into the postwar Neo-Nazi ideology and mythos and their implications. Similarly I owe a great debt of gratitude to British author and researcher Geoffrey Brooks, whose *Hitler's Terror Weapons: From V-1 to Vimana* I cited in my previous

book *The SS Brotherhood of the Bell*. Mr. Brooks contacted me as this book was being researched and written, and offered his investigative talents and observations on numerous details, which appear here. Additionally Mr. Brooks graciously took time out of his own busy schedule to conduct research in the Argentine national library and archives in Buenos Aires.

A word of thanks also to George Ann Hughes of the Byte Show, whose comment during an interview actually became the title of chapter two here.

Thanks also to Richard C. Hoagland for much encouragement and fascinating private discussion along the way while this book was being written, and of course, to my friend Tracy Fisher for continued prayers and encouragement. And as always, many thanks to the numerous readers who have contributed their comments, donations, and interest in my research over the past years.

Joseph P Farrell
Spearfish, South Dakota
2008

✠ Table of Contents ✠

ACKNOWLEDGEMENTS PREFACE

PART ONE: BACKGROUND AND THE STRATEGIC EVACUATION

1 FICTION AND MYTHOS: THE NOVELS OF WILHELM LANDIG, AND THE ESOTERIC CONNECTION

A. The Surrenders

1. The Japanese Surrender Instrument

2. The German Surrender Instruments

B. The Neo-Nazi Science Fiction Novels of Wilhelm Landig

1. Landig's First Novel: Götzen gegen Thule

2. Landig's Second Novel: Wolfszet um Thule

3. Landig's Third Novel: Rebellen für Thule

C. Unusual "Corroboration:" The Nazi UFO Mythos and Baron Rudolf Von Sebottendorff

D. The Curious Incident: Reinhard Schmidt's Contact with German-

Speaking UFO Occupants

1. Reinhold Schmidt's Actual Account.

- a. The Malfunctioning Ignition and a Nazi and Fascist Parallel
- b. The Pencil Thin Beam of Light
- c. "Inside the Ship"
- d. An Interesting Interest and Intriguing Observation
- e. Departure
- f. The Authorities Get Involved
- g. Schmidt Arrested and Committed
- 2. The Rosin Affidavit: An Interpretive Context
- E. Conclusions

2 THERE'S NAZIS IN THE BUSHES: THE PATTERN OF PREWAR CORPORATE-NAZI COOPERATION

- A. Wall Street and the Rise of Hitler
 - 1. Putting it into Perspective: The Presumptive Goals of the International Elite in Funding Communism and Nazism
 - 2. A Case in Point: Hitler's Reichsbank President: Dr. Hjalmar Horace Greeley Schacht
 - 3. International Cartel and Licensing Agreements Between I.G. Farben and American Corporations
 - a. The Dawes and Young Plans
 - 4. I.T. & T. and Nazi Germany
- B. A Brief Note About Prescott Bush, Union Banking Corporation, and Fritz Thyssen
- C. Conclusions

3 RAINDROPS KEEP FALLING ON MY HEAD: OPERATIONS REGENTRÖPFCHEN, ADLERFLUG AND BORMANN'S STRATEGIC EVACUATION PLAN

- A. The Beginnings of Evacuation: Operation Fireland
- B. Operation Bernhard
- C. The Hotel Maison Rouge Meeting: Operations
 - Regentröpfchen
 - and Adlerflug
 - 1. The Growth of Bormann's Power and International Network
 - 2. Bormann and I.G. Farben
 - 3. The Hotel Maison Rouge Meeting and Their Grand Design
 - 4. Allied Efforts to Roll Up The Bormann Flight Capital Plan
- D. Conclusions

4 THE POSTWAR SURVIVAL OF THE UNHOLY TRINITY: THE ESCAPE OF BORMANN, MÜLLER, AND KAMMLER

- A. The Escapes of Nazi Party Reichsleiter Martin Bormann and Gestapo Chief Heinrich Müller
 - 1. Bormann, Müller, and the Geli Raubal Affair
 - 2. The Ladislas Farrago-Paul Manning Scenario
 - a. Argentine Documents: Escape Via Genoa
 - b. Allen Dulles' Comment to Paul Manning
 - 3. The Carter Hydrick Scenario
 - a. And the Connection to the German Surrender
 - b. Geoffrey Brooks' Scenario: Invisible U-Boats
 - c. Hydrick on the Surrender of German A-Bomb Secrets & Enriched U-235: "Invisible" U-Boats Reconsidered
- (1) The Official Versions, and Their Problems
- (2) Obfuscating the Data and Confusing the Trails: Doubles
- (3) The Hydrick Scenario
 - (a) The Movements of Martin Bormann and Heinrich Müller
 - (b) The Movements of the U-234

- 4. The Velasco Scenario
- 5. A Reconciliation and Reconstruction
- B. The Escape of SS Obergruppenführer Hans Kammler
 - 1. Agoston: The Priest Disguise and a Bormann Parallel
 - 2. Nick Cook and the Luftwaffe's Kampfgeschwader 200: The Escape of Kammler and the Bell Courtesy of Martin Bormann
- C. Conclusions: A Possible Scenario

5. HACIENDAS AND HOTELS FOR HITLER: CONFRONTING THE FÜHRER'S SUICIDE STORY

- A. The 1964 Police Gazette Article
- B. Will the Real Adolf Hitler Please Die?
 - 1. The *Nexus* Magazine Series by Giordan Smith
 - 2. Two Possibilities
- C. Back to Velasco's Story: Hitler's Escape, and Eva Braun's Death
 - 1. Analysis and Reconciliation of Scenarios
 - 2. Corroboration from Argentina

6. THE RODENTS AT THE OTHER END OF THE RATLINES: JUAN DOMINGO PERÓN AND THE VATICAN CONNECTION

- A. The Colonels, the Colonel, and the Beginning of a Courtship
 - 1. Historical Background
 - a. Perón in Europe
 - b. Argentina and the Axis
 - 2. The Argentine Special Envoy and Von Ribbentropp
 - 3. An Unusual Encounter Between Representatives of the SS and Allen Dulles

- 4. The Colonels' Coup
- 5. Perón's "Third Position": Its International Geopolitical Implications
- 6. The Argentine Declaration of War on Germany, and Perón's Hidden Purpose
- B. The Ratlines and Argentina's Role
 - 1. The Ustashi-Vatican Dress Rehearsal
 - 2. The Three Argentine Ratline Routes
 - 3. Bormann's and Perón's Joint Bank Account

PART TWO:
THE DIALECTICAL MANIPULATION OF CONFLICT FOR FUN
AND
PROFIT

7. BORN-AGAIN NAZIS FIND ALLAH: WARTIME AND POSTWAR NAZI COLLABORATION WITH ARAB STATES AND RADICAL ISLAM

- A. Nazi Germany's Penetration of the Muslim World
 - 1. Iraq
 - 2. Iran
 - 3. Afghanistan
- B. The Grand Mufti of Jerusalem, Al-Husseini, and Nazism
 - 1. Hitler and Al-Husseini at Tea
 - 2. The First Suicide Squads and the Muslim Waffen SS
 - 3. Cousin Yasser Arafat
- C. The "Third Position" and the Egyptian Venture: Skorzeny, Schacht, Voss, and Nasser
 - 1. Wilhelm Voss and Otto Skorzeny in Gamel Abdul Nasser's Egypt

2. Schacht's Little Deal: The Jeddah Agreement

3. The Ultimate Geopolitical Goal: The "Third Position"

Again

a. An International Terrorists' Summit

b. The Neo-Nazi Connection to the Assassination of Pope John-Paul II

c. Mohamar Qaddafi's "Perónism"

d. The Historical Parallels and Geopolitical Implications of the "Third Position"

(1) Rapallo: The Pariahs Make a Deal

(2) Frederick the Great and the Partitions of Poland

8. WIEDERVEREINIGUNG: GERMANY REVIVES SOME OLD TRADITIONS

A. A Curious Incident: The GSG-9 and the Rescue of Andreas Strassmeir

1. Reunification: Kohl, Günter Strassmeir, and Nazi Anniversaries

2. Implications of the Incident: U.S. Complicity or Not?

3. Kohl's Neo-Nazi Connections and the Neo-Nazi Push for Reunification

4. The Shotgun Wedding

5. The Ugly Side of Reunification

a. The Rostock Incident

b. The Post-Reunification Surge of Terrorism

B. Flexing Muscle and Other Old Traditions of the Third Position

1. The Soviet Implosion

2. German Investment Strategy

3. Breaking Free of NATO

4. Germany and the Arms Trade

5. Germany and Saddam Hussein's WMDs and Secret Police

6. "Third Position" German Initiatives in Eastern and Central Europe

- a. Revising Versailles Once Again: Germany and the Crack-up of Czechoslovakia
- b. Silesia, “Kaliningrad,” and Poland
- c. Revising Versailles Yet Again: Germany, Croatia, and the Crack-up of Yugoslavia
- 7. The First Post-Unification Chief of the *Bundeswehr* and the “Mobile Strike Force”
- C. Deep History and “Deep Politics”: Connecting the Dots
 - 1. The New Corporate Ambassadors: Rudel and Skorzeny as Bormann’s Nazi Party Liaison Officers to Siemens and Krupp
 - 2. Gehlen: The Key Connection of the Scenario

PART THREE: **THE DEVELOPMENT AND CONTROL OF NEW ENERGY TECHNOLOGIES**

9. DON’T CRY FOR ME ARGENTINA: DR. RONALD RICHTER AND PERÓN’S CONTROLLED FUSION PROJECT AT HUEMUL ISLAND

- A. And Now, a Word from President Perón
- B. The Argentine High Commission’s Report and Dr. Richter’s Strange Behavior
 - 1. Dr. Richter’s Claims to Have Found a New Principle of Physical, Nuclear Action
 - 2. The Nature of the Principle: Precession
 - 3. Dr. Richter’s Extremely Anomalous Behavior

- 4. A New Anomaly and the Argentine Advisory Review Commission's own Anomalous Behavior
- 5. The Heavy Water Production Facility and Odder Behavior from Dr Richter and His Team
- C. Richters' Replies and The Commission's Ripostes

10. BALLS, BELLS, BORMANN, AND BARILOCHE: A SPECULATIVE RECONSTRUCTION OF RICHTER'S BARILOCHE FUSION PROJECT

- A. Perón Gets Help from a Bilderberger
 - 1. And America's Little-Known Ambiguity toward Dr. Richter
 - 2. Richter's Paperclip File Air Intelligence Report Summary of His Wartime research in Germany
- B. A Strange Presence in Bariloche After the Affair
 - 1. A Look Around Bariloche
 - 2. Bariloche's Prestigious Visitor-Resident(s)
- C. Dr. Richter's Theoretical Explanations
 - 1. The Origins of the Huemul Project: Gerlach and Diebner
 - 2. Richter's Conceptions and American Interest
 - a. His Conceptions as Recorded by the Argentine Investigative Commission
 - b. Richter's Paperclip File and American Ambiguity
 - 3. Another Strange Parallel, Dr. Philo Farnsworth's Plasmator, and Another Strange Nazi Connection: IT&T
 - 4. Fusion, Torsion, and Stars: The Work of Dr. Nikolai Kozyrev
 - 5. Richter, Ram Jets, Shockwaves, and Aurora
 - 6. Ball Lightning, The A.E.G and Richter
 - 7. The Bell Flies to Argentina: Brooks, Ball Lightning, A.E.G., and the Bell

- 8. A Possible Corporate Connection to Argentina's Huemul Project: A.E.G., and Back to the Bell
- D. The Conclusions Imply a Possible Scenario

PART FOUR: **THE CONTROL OF SPACE**

11. MASONS, MAGICIANS, AND NAZIS: RICHARD C. HOAGLAND AND MIKE BARA ON NASA'S SECRET HISTORY

A. Ancient Names and Ritual Alignments

- 1. NASA and NACA: "Never A Straight Answer" from "Not A Civilian Agency"
- 2. Masons, Magicians, and Nazis
- 3. Mission Patches, Ancient Names, and Ritual Alignments
 - a. Mission Patches
 - b. Ancient Names
 - c. Ritual Alignments
 - d. The Biggest "Ritual Alignment" of them All
- 4. A Stunning and Chilling Scenario: The Implications of the *Dark Mission* Conclusions Regarding the Nazis

B. The Real Apollo Missions

- 1. Hoagland's Conclusions
- 2. Some Implications of Their Remarks in a Wider Context
- 3. The Wider Implications

12. CONCLUSIONS: AN INTERESTING TIMELINE AND A POSSIBLE SCENARIO

- A. 1920s-1930s: Alchemy, Esotericism, The SS and the Unified

Field Theory Craze

B. 1943-1945: Strange Events from the Middle to the End of
World

War Two

C. 1946-1961 and Beyond: Postwar Shenanigans

APPENDICES

BIBLIOGRAPHY

✘ Preface ✘

Much has been written by writers and researchers more capable than I about the extent and dimensions of the Nazi survival of World War Two in enclaves in South America and elsewhere. But other than the groundbreaking work of Peter Levenda's *Unholy Alliance* and his masterful trilogy *Sinister Forces: A Grimoire of American Political Witchcraft*, or Jim Marr's more recent *The Rise of the Fourth Reich*, much of the other literature focuses on the survival and eventual apprehension of a few individual, high profile Nazis such as Adolf Eichmann or Klaus Barbie, or in the case of Ladislav Farago's *Aftermath: Martin Bormann and the Fourth Reich*, speculating on the implications of the probable survival of Bormann in South America. The subtitle of Farago's book suggests that wider implication: that Nazism *itself* survived as a coherent though covert ideological force in the postwar world. Therein lies the problem, for the bulk of Farago's book does little to explore the wider implications that his own subtitle suggested. Only a few researchers like Levenda, Marrs, Henry Stevens, Igor Witkowski, or I have suggested that the Nazi survival was more extensive, coordinated, and for a long-range purpose, but even then, however, the main thrust of these works has been primarily limited to political and economic themes.

All that recently changed, however, when authors Richard C. Hoagland and Mike Bara joined the previous roll call from an unlikely quarter and with an unlikely perspective with their New York Times bestselling book *Dark Mission: The Secret History of NASA*, in which, as we shall see in the main section of this book, they suggest that one such possible long-range purpose was the exploitation of America's space program for some hidden Nazi purpose. In other words, one could not limit the activities and agenda of the postwar

Nazi International to economics and politics, but had to cast a wider net and include science and space as well. And that, of course, implies that the Nazi International had a comprehensive, coordinated agenda with long range goals.

Consequently, by an examination of some but by no means all of the various postwar activities of this Nazi International, this book aims to make the preliminary case that this organization intended nothing less than to exercise – at the minimum – significant influence over the fields of the development of exotic physics and technologies, over space, over economics and global finance, and over the creation, or exacerbation and exploitation, of conflict, and optimally aimed at *control* over them. Accordingly, the goals of Nazism had not changed since the war, but remained the same: world domination, this time not by tanks and dive-bombers, but by stock certificates and the infiltration of loyal personnel into postwar institutions.

As already mentioned, even more recently, well-known author and JFK assassination researcher Jim Marrs has joined this slowly expanding list with his own book, *The Rise of the Fourth Reich*, suggesting even more connections between the events of the post-9/11 world, the fall of the Third Reich, and the rise of increasingly fascist policies and police-state “snitch society” cultures in the very nations that helped defeat that enemy. Marrs pointedly raises the question of whether or not that enemy was really defeated. As I have heard Mr. Marrs mention on numerous occasions, some of which were while he was interviewing this author, it was, after all, *Germany* and the *German Armed Forces* that surrendered, not the *Nazi Party*. This, as we shall shortly see, is far from being a merely rhetorical statement, but is one of those little noticed but nevertheless obvious facts.

It is time, then, not only to assemble the disparate pieces scattered not only throughout other authors’ works as well as my own, but to add many *new* pieces and considerations, some of which were previously known and a matter of public record, but not properly interpreted in the light of their scientific and political implications for postwar Nazi survival and organization. Once they are thus assembled, a clear picture will emerge of a deliberate and

coordinated Nazi effort to penetrate, significantly influence, and ultimately to control sensitive scientific, economic, and policy-making agencies and bureaus of its former enemies and to manipulate political and economic events to its own ends. In short, the grand design, conceived and executed before the war's end by Nazi Party *Reichsleiter* Martin Bormann himself, was to transform *National Socialism* into *International Fascism*, and to infiltrate, and eventually control, key areas of the very nations that had defeated the Third Reich and driven the Party back underground.

With this in mind, there are two caveats the reader must consider throughout the remainder of this work.

First, this book is a departure, in some respects, from my previous books¹ in that the emphasis is not as heavily on the scientific or physics aspects as it is on the conspiratorial aspects of the story, though here again, there is certainly a scientific aspect, as we shall see when we turn to consider the implications of a little-known Argentine nuclear project in the environs of San Carlos de Bariloche. This book is thus, so to speak, my first, though doubtless not my last, foray into the realm of "conspiracy theory," and hence a caveat about conspiracy theory is necessary. The old adage that Americans were taught to believe in "accidents of history" whereas Europeans made conspiracy theories of history something of a "cottage industry" is simply no longer true. Gone are the days that a Warren Commission can sell the idea of a lone nut and a magic bullet as the movers and shakers in the most signally important political event in twentieth century American political history, notwithstanding the casuistry of Gerald Posner and other priests of the status quo in defense of the Warren Commission religious dogma. Gone are the days that the BCCI scandal, the Savings and Loan scandal, the Nugan Hand bank scandal, the Oklahoma City Bombing or any number of a host of other post-JFK scandals can be written off by smiling Lloyd Bentsens or Clark Cliffords or Janet Renos as the disconnected affairs of one or two "lone nuts" and their suspiciously credulous lackeys.

The reason is as simple as 9/11 itself: the federal government itself has now entered the conspiracy theory business with its whole official "explanation" of 9/11. To be sure, we were now dealing with several "lone nuts" of the fanatical Muslim variety, but by dint of that

very admission, we were, and are, dealing with an extraordinarily complex international conspiracy, albeit a very badly scripted one.

This book is likewise about a conspiracy theory, or perhaps better put, a conspiracy *hypothesis* . It remains for the reader to judge if it is a badly scripted one or not. That said, however, one thing this book is *not* to be mistaken for is that it is *not* proposing that the Nazis or their descendants are “behind it all,” but rather, that they and their contemporary descendants constitute but one of the major hidden players vying for power in a vast postwar global chess game that comprises *other* “internationals,” international finance and banking, the “clerical” international, the Communist international, the “occult” international, and so on. No attempt, in other words, is made here to construct some sort of “Grand Unified Conspiracy Theory” of modern history corresponding to a similar sort of theory in physics. The reader is free to take this information and to confect his own such theory if he wishes, but with the clear understanding that I am *not* the one doing so. I am merely proposing an extensive but nevertheless limited hypothesis to explain events that in my opinion cannot be explained as well by alternative hypotheses.

And this leads us to the second caveat.

Like all conspiracy theories, the hypothetical case made here is circumstantial. It remains, again, for the reader to judge if a plausible and reasonable case has been made. It need hardly be stated here that a circumstantial case does not necessarily mean a *compelling* one, nor does it necessarily mean an *invalid* one. It is again up to the individual reader to weigh the evidence and arguments, and draw his own conclusions.

With that in mind, however, the reader is advised to ask himself one question upon the conclusion of reading and considering this book: Can he find an insurance company to compile actuarial tables, or a Las Vegas bookmaker to lay odds that what has been presented is *not* true? And will he, the reader, take those odds?

Joseph P Farrell
Spearfish, South Dakota
2008

¹ These are as follows: *The Giza Death Star: The Paleophysics of the Military Compound at Giza* (2000); *The Giza Death Star Deployed: The Physics and Engineering of the Great Pyramid* (2003); *Reich of the Black Sun: Nazi Secret Weapons and the Cold War Allied Legend* (2004); *The Giza Death Star Destroyed: The Ancient War for Future Science* (2005); *The SS Brotherhood of the Bell: NASA's Nazis, JFK, and Majic-12* (2006); *The Cosmic War: Interplanetary Warfare, Modern Physics, and Ancient Texts* (2007); *Secrets of the Unified Field: The Philadelphia Experiment, the Nazi Bell, and the Discarded Theory* (2008); all published by Adventures Unlimited Press, Kempton, Illinois; and *The Philosophers' Stone: The American "Gold," The Soviet "Mercury," and the Nazi "Serum"* published by Feral House, Port Townsend, Washington.

Part One: Background and the Strategic Evacuation

“In later research I discovered, however, that the story about the financial properties being expropriated once and for all by the United States government, while true in form, was not true in reality. It was yet another effort to create a fog behind which the truth could be hidden.”

Carter Plymton Hydrick, *Critical Mass*, p. 189.

✘ 1 ✘

Fiction and Mythos: The Novels of Wilhelm Landig, and The Esoteric Connection

*“The role of this American power elite in the rise of Hitler
should also be
viewed in conjunction with a little-known aspect of Hitlerism only
now
being explored: the mystical origins of Nazism, and its relations
with the
Thule Society and with other conspiratorial groups. “
Anthony Sutton¹*

A. The Surrenders

No sooner was the badly written tragedy of World War Two over when everyone began to re-write the screenplay. For their part, the victorious western Allies began to portray the Nazis not only as nuclear bunglers who could not construct a proper reactor, much less an atom bomb, but also rightly and justly illumined the genocidal crimes of the Nazi regime as further proof of the insanity that had once held all of Germany and Europe in its grip.² For their part, the Soviets began to raise serious public - and private - reservations about the suicides of Adolf and Eva Hitler, as we shall see in a subsequent chapter, but no one was paying them much attention, as the Soviet Union quickly replaced Nazi Germany in “most favored enemy” status.

And for their part, the many Nazis who found themselves confronted by the regime's crimes after the war struggled to find justification for their continued adherence to "the cause," and, like their western and Soviet counterparts, quickly set about to re-write history. Many did so in the guise of fiction, whether that of the "scholarship" of Holocaust denial,³ or the more properly science fiction novels of Austrian Neo-Nazi Wilhelm Landig, who will afford our "port of entry" into the study of the Nazi International.

However, in order to appreciate the significance of the allegations in Landig's science fiction novels, it is necessary to view them in the context of the German and Japanese surrenders themselves.

1. The Japanese Surrender Instrument

At the end of the Second World War, the western Allies and the Soviet Union were confronted with a large problem, and the problem was how to handle Germany's surrender. However, in order to see what the problem was, we have to go back into history to the end of World War One, and also to go forward to the period of the few months in history between the German capitulation to the Japanese surrender. In the first instance, the problem the Allies faced was similar to that posed by the German request for an armistice and negotiated surrender at the end of World War One. Then, as is well known, the Kaiser had abdicated, leaving the government of Germany in the hands of a provisional civilian government, which began the process of surrendering to the Allies. But the German *military*, (which had no representatives at the actual signing of the Versailles treaty, and which in fact had had some of its senior generals – Erich Ludendorff, for example – actually arguing for a continuation of the war) did *not* surrender. The problem was, then, that the *government* surrendered, and the *military* did not, giving rise to the "loophole" later exploited by Nazi propaganda about the "stab in the back" by "Jewish socialists."

For the Allies at the end of World War Two, then, the last thing they wanted was to create the opportunity for a replay of World War One, or to allow any potential for a Nazi resurgence in Germany through a similar propaganda tactic. But a glance at the instruments

of surrender only serves to highlight this problem rather dramatically. First, we will look at the Japanese instrument of surrender.

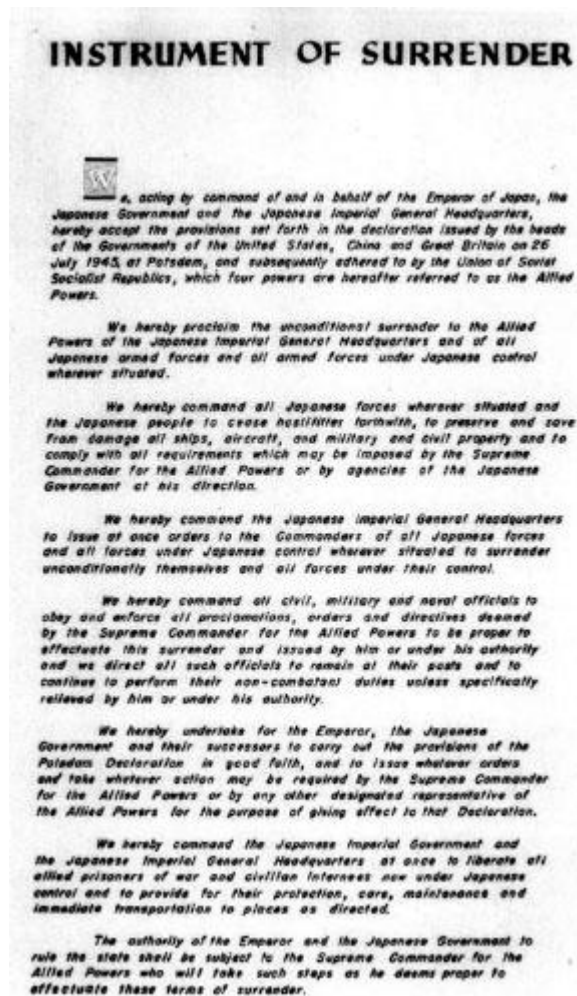

Actual Japanese Surrender Instrument, Page One

The text of this document reads as follows:

We, acting by command of and in behalf of the Emperor of Japan, the Japanese Government and the Japanese Imperial General Headquarters, hereby accept the provisions set forth in the declaration issued by the heads of the Governments of the United States, China and Great Britain on 26 July, 1945, at Potsdam, and subsequently adhered to by the Union of Soviet

Socialist Republics, which four powers are hereafter referred to as the Allied Powers.

We hereby proclaim the unconditional surrender to the Allied Powers of the Japanese Imperial General Headquarters and of all Japanese armed forces and all armed forces under Japanese control wherever situated.

We hereby command all Japanese forces wherever situated and the Japanese people to cease hostilities forthwith, to preserve and save from damage all ships, aircraft, and military and civil property and to comply with all requirements which may be imposed by the Supreme Commander of the Allied Powers or by agencies of the Japanese Government at his direction.

We hereby command the Japanese Imperial General Headquarters to issue at once orders to the Commanders of all Japanese forces and all forces under Japanese control wherever situated to surrender unconditionally themselves and all forces under their control.

We hereby command all civil, military and naval officials to obey and enforce all proclamations, orders and directives deemed by the Supreme Commander for the Allied Powers to be proper to effectuate this surrender and issued by him or under his authority and we direct all such officials to remain at their posts and to continue to perform their non-combatant duties unless specifically relieved by him or under his authority.

We hereby undertake for the Emperor, the Japanese Government and their successors to carry out the provisions of the Potsdam Declaration in good faith, and to issue whatever orders and take whatever action may be required by the Supreme Commander for the Allied Powers for the purpose of giving effect to that Declaration.

We hereby command the Japanese Imperial Government and the Japanese Imperial General Headquarters at once to liberate all allied prisoners of war and civilian internees now under Japanese control and to provide for their protection, care, maintenance and immediate transportation to places as directed.

The authority of the Emperor and the Japanese Government to rule the state shall be subject to the Supreme Commander for the Allied Powers who will take such steps as he deems proper to effectuate these terms of surrender.

Signed at Tokyo Bay, Japan at 0904 on the second day of September, 1945,

/s/Mamoru Shigemitsu

By Command and in behalf of the Emperor of Japan and the Japanese Government

/s/Yoshijiro Umezu

By Command and in behalf of the Japanese Imperial Headquarters

Accepted at Tokyo Bay, Japan at 0908 on the second day of September, 1945, for the United States, Republic of China, United Kingdom, and the Union of Soviet Socialist Republics, and in the interests of the other United Nations at war with Japan,

/s/ Douglas MacArthur

Supreme Commander for the Allied Powers.

/s/ C.W. Nimitz

United States Representative

/s/Hsu Yung-Ch'ang

Republic of China Representative

/s/Kuzma Derevyanko

Union of Soviet Socialist Republics Representative

/s/Thomas Blamey

Commonwealth of Australia Representative

/s/L. Moore Cosgrave

Dominion of Canada Representative

/s/Jacques LeClerc

Provisional Government of the French Republic Representative

/s/C.E.L. Helfich

Kingdom of the Netherlands Representative

/s/Leonard M. Isitt
Dominion of New Zealand Representative

Note that the instrument leaves no legalities to chance, for both the Emperor, the Japanese Government(that is to say, the imperial cabinet, Diet, judiciary), *and* the Japanese military, are mentioned explicitly.

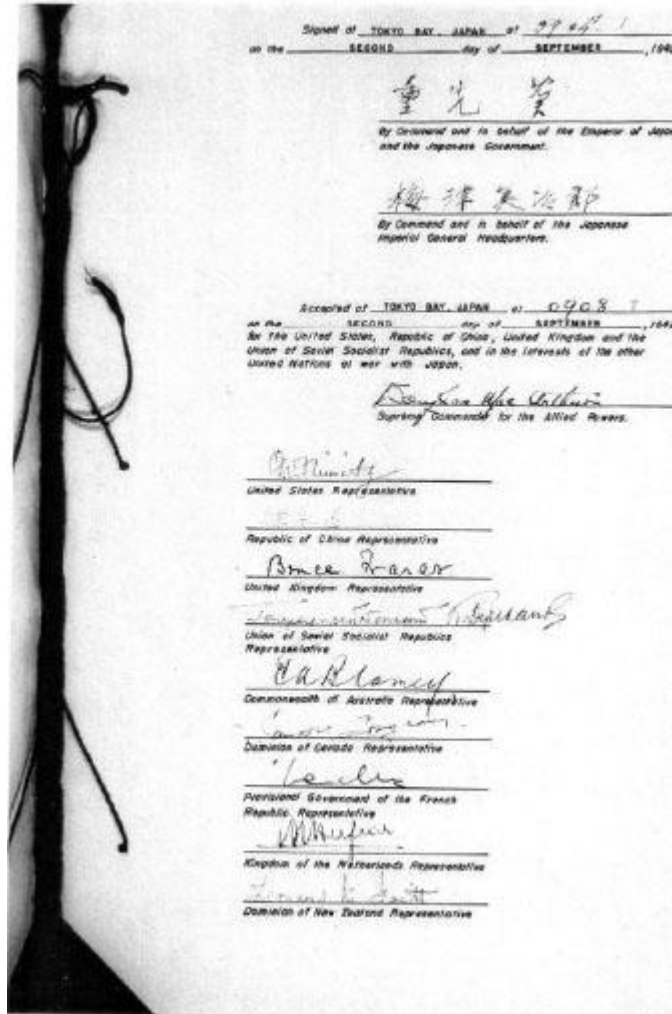

Japanese Instrument of Surrender, Page Two

2. The German Surrender Instruments

But when it comes to the German surrender, or rather, surrenders, things are not so tidy, for indeed there were two separate surrenders, the first to the Allies at Rheims, France, on May 7, 1945, and the second, at the behest of the Soviets who desired the presence of a more high ranking Soviet representative in the form of Marshal Georgi Zhukov, in Berlin, on May 8, 1945.

The terms of the German surrender of May 7, 1945, read as follows:

1. We the undersigned, acting by authority of the German High Command, hereby surrender unconditionally to the Supreme Commander, Allied Expeditionary Force and simultaneously to the Soviet High Command all forces on land, sea, and in the air who are at this date under German control.

2. The German High Command will at once issue orders to all German military, naval and air authorities and to all forces under German control to cease active operations at 2301 hours Central European time on 8 May and to remain in the positions occupied at that time. No ship, vessel, or aircraft is to be scuttled, or any damage done to their hull, machinery or equipment.

3. The German High Command will at once issue to the appropriate commanders, and ensure the carrying out of any further orders issued by the Supreme Commander, Allied Expeditionary Force and by the Soviet High Command.

4. The act of military surrender is without prejudice to, and will be superseded by any general instrument of surrender imposed by, or on behalf of the United Nations and applicable to Germany and the Germany armed forces as a whole.

5. In the event of the German High Command or any of the forces under their control failing to act in accordance with this Act of Surrender, the Supreme Commander, Allied Expeditionary Force and the Soviet High Command will take such punitive or other action as they deem appropriate.

Signed at Rheims at 0241 on the 7th day of May, 1945,
France

On behalf of the German High Command,
(Colonel-General Alfred) Jodl

In the Presence of
On Behalf of the Supreme Commander, Allied Expeditionary
Force,
(General) W.B. Smith

On behalf of the Soviet High Command,
Sousloparov

F. Sevez,
Major General, French Army (Witness)

And the text of the instrument of the May 8, 1945 Berlin surrender reads as follows:

1. We the undersigned, acting by authority of the German High Command, hereby surrender unconditionally to the Supreme Commander, Allied Expeditionary Force and simultaneously to the Supreme High Command of the Red Army all forces on land, at sea, and in the air who are at this date under German control.
2. The German High Command will at once issue orders to all German military, naval and air authorities and to all forces under German control to cease active operations at 2301 hours Central European time on 8th May 1945, to remain in all positions occupied at that time and to disarm completely, handing over their weapons and equipment to the local allied commanders or officers designated by Representatives of the Allied Supreme Commands. *No ship, vessel, or aircraft is to be scuttled, or any damage done to their hull, machinery or equipment, and also to machines of all kinds, armament, apparatus, and all the technical means of prosecution of war in general.*
3. The German High Command will at once issue to the appropriate commanders, and ensure the carrying out of any

further orders issued by the Supreme Commander, Allied Expeditionary Force and by the Supreme Command of the Red Army.

4. This act of military surrender is without prejudice to, and will be superseded by any general instrument of surrender imposed by, or on behalf of the United Nations and applicable to Germany and the German armed forces as a whole.
5. In the event of the German High Command or any of the forces under their control failing to act in accordance with this Act of Surrender, the Supreme Commander, Allied Expeditionary Force and the Supreme Command of the Red Army will take such punitive or other action as they deem appropriate.
6. This Act is drawn up in the English, Russian and German languages. The English and Russian are the only authentic texts.

Signed at Berlin on the 8th day of May, 1945,

(Admiral Hans-Georg) Von Friedeburg
(Field Marshal Wilhelm) Keitel
(Colonel-General Hans-Jürgen) Stumpff

In the Presence of
(Air Marshal) A.W. Tedder,
On Behalf of the Supreme Commander, Allied
Expeditionary Force

(Marshal) Georgi Zhukov,
On Behalf of the Supreme High Command of the Red Army

Witnesses:
F. de Lattre-Tassigny,
General Commanding in Chief,
French First Army

Carl Spaatz

General, Commanding The United States Strategic Air Force

The careful reader will have noticed at once the discrepancy between the two German surrenders on the one hand, and the Japanese surrender, on the other, for in the case of the Japanese surrender, it is explicit and clear that the surrender is being made by and for the Imperial government and all its departments, *and* the Imperial Japanese military.

However, in the case of the German surrenders, there is no mention of the Reich government of Germany, which by now had, under Adolf Hitler's personal orders, been transferred from him as Führer and Reich Chancellor, to Grand Admiral Karl Dönitz who succeeded him as Reich President in the final week of the war. It was the German *military* that was surrendering to the Allied *military*, for all signatories were signing as representatives for their nations' respective militaries; thus, for the Allies, the German government in a sense did not even exist. Consequently, almost the exact *opposite legal* situation was created at the end of World War Two as far as Germany was concerned than that which obtained with the German surrender in World War One. The Allies were taking no chances that the German military would not be seen as surrendering, but in the process, they neglected to mention the government of the Third Reich itself and, more importantly, the Nazi Party. Granted, the fourth protocol of the surrender explicitly states that the military surrender can and is to be superseded by subsequent "general surrender" terms, which implicate the Reich government clearly in the process.

But there is a further problem.

The Nazi Party, which had constructed itself as a parallel bureaucracy to the agencies of the German government, and which, indeed, under Party *Reichsleiters* Rudolf Hess, and later Martin Bormann, had infiltrated all branches of the government while remaining a separate entity, was not formally represented in the surrender itself at all!

In short, while the door is open to a technical argument whether or not the Reich government did or did not surrender – depending on whether one argues that the Allies did or did not recognize Dönitz's government⁴ – the door is not open as to whether or not the parallel

bureaucracy of the National Socialist German Workers' Party surrendered, because no such Party representative was ever present at the surrenders. To put it succinctly, *the Allies had missed the golden opportunity to insist that a representative of the Nazi Party sign an instrument of the surrender and abolition of the Party!* The German armed forces surrendered, and Germany surrendered, but the Nazi Party did not.

And this, of course, was the proverbial camel's nose in the doorway that permitted postwar neo-Nazism to insist that the party and its ideals, goals, *projects*, and *organization* were alive and well, as we shall now see. Indeed, if no legal surrender of the Party or its favored organs and instrumentalities – the SS for example – was ever effected, then this left their chains of command *formally and in practice intact*. In a certain sense, the bungled surrenders helped to feed not only the mythos, but the reality, of Nazi survival and of its internationalization.



*Grand Admiral (Großadmiral) Karl Dönitz,
Second Reich President of Nazi Germany⁵*

The SS was, of course, condemned as a criminal organization during the Nuremberg war crimes tribunals along with the Nazi Party itself, and thus this condemnation can claim a dubious sanction in international law, but this fact only highlights the “missed opportunity”

of the surrenders themselves. Why did the Allies not *insist* on some high-ranking representative of the Nazi Party being present at the surrender, and signing a protocol stating the explicit abolition of the Party and its organizations in perpetuity and by law, thus affording the Allies a far cleaner legal case to prosecute the Party or any organizations it spawned in international law? It might be argued that such representation could not come from any regional officeholder of the Party, but would have to come from the level of the Party chancery itself, i.e., from *Reichsleiter* Bormann or a duly appointed representative. Presumably the Allies could not press for such presentation because, ostensibly, Martin Bormann had died fleeing Berlin. But there is another, extremely disturbing, possibility as will be seen in a subsequent chapter.

There is a final point to notice about the second, “Berlin” surrender, and that is the protocol that stipulates that all of Germany’s technological equipment pertaining to the prosecution of war was to remain intact.

It is clear where the Allies’ and Soviets’ priorities laid.

B. The Neo-Nazi Science Fiction Novels of Wilhelm Landig

So where do Wilhelm Landig’s postwar Neo-Nazi science fiction novels fit in to this picture?

According to historian and Nazi scholar Nicholas Goodrick-Clarke, Landig was a member of that

significant minority of Nazi loyalists (who) found defeat intolerable after the power and exuberance of Germany’s continental domination. In the early 1950s, an Aryan-Nordic mythology took root in Vienna that was in marked contrast to the flagrant Hitler worship of postwar Anglo-American Nazi cults. Since Hitler and politics were now such painful memories, this mythology was characterized by speculations about ancient Nordic races, Thule and Atlantis, and Germanic religion. Also important was the rediscovery of ideas and individuals in the Ahnenerbe, Heinrich Himmler’s SS office that researched Aryan archaeology and anthropology from 1935 to 1945. Apocalyptic

hopes for national resurrection and salvation focused on wild speculations about the supposed existence of German miracle weapons, including flying saucers and secret polar bases at the end of the war.... The origins of this mystique lies in a small occult-racist circle that first gathered for discussions at the studio of the designer Wilhelm Landig (1909-1997).⁶

Landig, born in Vienna in 1909, was “a staunch pan-German nationalist.”⁷ Joining two of the many *Freikorps*, one of the private armies that flourished in Germany and Austria after World War One, Landig subsequently held various governmental posts in the Third Reich until he joined the Waffen SS and fought in the antipartisan campaigns in the Balkans from 1942-1944, for which he received decorations from the Third Reich and from its puppet Ustashi regime in Croatia.⁸ Goodrick-Clarke then notes that “in 1944 he was directed from Belgrade back to Vienna for ‘special tasks’ involving new military technology.”⁹ While this calls forth no further comment from Goodrick-Clarke, nor do we know what Landig’s “special tasks” really comprised, we are permitted to speculate.

According to British researcher Tom Agoston, who first broke the story of SS *Obergruppenführer* Hans Kammler’s super-secret black projects “think tank” to an English-speaking audience in his book *Blunder! How the U.S. Gave Away Nazi Super Secrets to Russia*, Vienna was precisely one home of secret Nazi research done for Kammler’s “think tank.” And according to authors Renato Vesco and David Hatcher Childress, Vienna was the home to some of Nazi Germany’s highly secret *laser* research.¹⁰ One may reasonably speculate, therefore, that Landig did indeed come into personal contact with and awareness of some of the projects that he fictionalizes in his novels.

Landig was not, however, merely a novelist churning out Neo-Nazi science fiction of dubious moral and literary quality. He was also “a political activist.” According to Goodrick-Clarke:

In the mid-1950s he was the Austrian representative of the European Social Movement (ESB), the fascist international organization founded at Rome and Malmö (Sweden), which

sought German alliance with a worldwide league of non-aligned nations, especially the Arab states, between the two superpowers. In 1955 Landig was in regular contact with Per Engdahl, the Swedish neo-Nazi leader, and Karl-Heinz Priester, a former Hitler Youth leader who had extensive contacts in the German nationalist underground. In 1958 Landig founded his own nationalist press, Volkstum-Verlag, whose logo featured an Ostrogothic eagle brooch dating from the reign of Theodorich the Great in the fifth century.... In 1970 Wilhelm Landig became the Austrian representative of the World Anti-Communist League (WACL), founded in Taiwan in 1967 after a merger of the Asian people's Anti-Communist League and the Anti-Bolshevik Bloc of Nations. This was arguably the most important far-right network in the world and accounts for Landig's highly informed international news service.¹¹

As will be seen in subsequent chapters, there is more afoot with Neo-Nazi machinations in Arab states, and in the creation of a third bloc of nations to offset the two superpowers, than meets the eye. And as will also be seen, the World Anti-Communist League has more than its own fair share of connections to postwar Nazis and Fascists.

But in addition to all this activism, Landig had one other activity, for after his arrest and internment in a British POW camp from 1945-1947 as a former SS member, Landig upon his release "entered the world of inter-Allied espionage, hawking low- and medium-grade Soviet intelligence to Western security services."¹² In other words, Landig was, in some capacity, part of the vast network of Nazi spies operating in Europe, and he functioned most likely as a low level member of General Reinhard Gehlen's "Gehlenorg," headquartered in Pullach, just outside of Munich. General Gehlen was, of course, the German general who was the head of all German military intelligence during the Nazi era for eastern Europe and the Soviet Union, the *Fremde Heere Ost* or "Foreign Armies East", and he was also, of course, the General who secretly negotiated with American OSS station chief in Zurich, Switzerland, Allen Dulles, to turn over to the Americans his entire network so long as the network remained in

the day-to-day operational control of Gehlen himself! As I have noted in my previous book *The SS Brotherhood of the Bell*, this meant that before President Truman's signature was even dry on the National Security Act of 1947 which created the CIA, its civilian character and charter had already been severely compromised, since almost its entire operational and analytical "Soviet desk" was staffed by a bunch of "former" Nazis![13](#)



General Reinhard Gehlen During the War



*OSS Station Zurich Station Chief, Subsequent CIA Director, and
Warren Commission Member Allen Dulles*

1. Landig's First Novel: Götzen gegen Thule

It is in Landig's "Thule" trilogy of novels that the myths of Nazi survival find their firmest and clearest postwar expression.

The first of these, *Götzen gegen Thule* (1971), was begun in the late 1950s...Theories of Aryan polar origins and Atlantis are mixed with powerful new nationalist myths of 'the last battalion,' secret German UFO bases in the Arctic, alchemy, Grail myths and Cathar heresies, and a Nazi-Tibetan connection involving Himalayan masters and an underground kingdom in Mongolia.¹⁴

However, it is what Goodrick-Clark does *not* mention – the novel's subtitle - that is most significant, for Landig's subtitle says that it is *Ein Roman voller Wirklichkeiten*, a "novel full of realities."

And this may not be far from the truth, for as I point out in my book *The Philosophers' Stone*, the alchemical influence within Himmler's SS was pervasive.¹⁵ Additionally, that influence included a fascination with the Grail,¹⁶ with the Cathars and the Languedoc region of southwestern France that they inhabited,¹⁷ and as is also well known, Himmler personally sponsored the SS expedition to Tibet in 1938-1939.¹⁸

Indeed, there is much more to Landig's thousand page monster novel than just this, and Goodrick-Clarke's summary is as good as any:

Götzen gegen Thule is an allegory of the Landig circle's attempts to make contact with an esoteric center of Nordic traditions, the legendary realm of Thule, the final bastion of the Germanic world in defeat. The story describes the world odyssey of a small group of SS soldiers and Luftwaffe airmen

across four continents in the immediate aftermath of the Second World War. In the first part of the novel the two airmen, Recke (“berseker”) and Reimer (“bard”), are sent from Norway to Point 103, a secret base that has been established by the esoteric SS elite in Arctic Canada, unknown to the Allies and also to most German authorities. Point 103 is a large underground complex equipped with highly advanced technology, including flying saucers whose apparent mission is to maintain the spirit of German defense after the final surrender of the Reich.... Its symbol is the alchemical Black Sun, a round disk that is not exactly black but the deepest violet.

Like Landig’s bloc of unaligned nations against the superpowers, Point 103 seeks to promote an international alliance for the ideals of the Black Sun. Many foreign delegates attend a great conference held in the assembly hall of the base decorated with astrological symbols and an enormous icon of Mithras slaying the Bull. The delegates have all been flown to the conference by means of the V-7, a German flying saucer with a speed of 4,000 kilometers per hour and a range of 2,000 kilometers. These include a Tibetan lama, Japanese, Chinese, and American officers, Indians, Arabs, Persians, an Ethiopian, a Brazilian officer, a Venezuelan, a Siamese and a full-blooded Mexican Indian. The Arabs speak darkly of secret Islamic brotherhoods, the Indians and Persians invoke old Aryan traditions, the Orientals allude to their occult orders and a mysterious world center. Attired in their uniforms or national dress, many of the delegates make speeches identifying their national myths and ideals with those of the Thule and pledge their full support when the time comes for action.¹⁹

Peeling back the fantastic layers, however, reveals an interesting picture.

Boiling Landig’s plot down to its basic essentials, one has the following intriguing list:

- 1) A secret base in the Canadian Arctic, i.e., a secret base in a polar or cold region that is *remote* and unknown to the Allies;

- 2) This base is staffed by former SS and Luftwaffe officers and men;
- 3) The point of departure to this secret enclave was Norway;
- 4) The secret base employs (and presumably develops) advanced technology, which includes flying saucers, i.e., advanced aerodynes employing advanced propulsion;
- 5) This base is intimately involved with the creation of a bloc of nations to offset the geopolitical preponderance of the Soviet Union and the United States;
- 6) This bloc of nations in turn represents the internationalization of the Nazi ideology, and extends to Latin America, the Orient, and various American Indians, that is, there is an international covert Nazi *organization, and that Nazism has internationalized itself into a multi-ethnic Fascist organization with a German core;*
- 7) This bloc also consists to some extent of “secret Islamic brotherhoods” and Oriental “occult orders” and a “world center” in presumably covert conflict with the two superpowers and their aligned blocs of nations.

2. Landig's Second Novel: Wolfzeit

In Landig's second novel, *Wolfszeit um Thule* (1980), a similar odyssey is described:

Here the narrative follows the adventures of two naval officers, Krall and Hellfeldt, and SS-Major Eyken, formerly stationed at Point 103. Assigned to a flotilla of German U-boats which leaves Norway in early May 1945, they achieve a devastating victory over an Allied naval convoy in the North Atlantic. The flotilla collects all equipment and personnel from Point 103, which is then evacuated and totally destroyed... The flotilla sets sail for the South Atlantic to make contact with the new bases of the Black Sun, the epithet of the shadow Reich government in exile. The geographical focus of this novel thus indicates the shift of Nazi survival toward Latin America and Antarctica, the new Thule of the Southern Hemisphere.²⁰

Before proceeding with Goodrick-Clarke's summary of this second novel, note what we have once again:

- 1) The expedition departs by U-boat from Norway once again;
- 2) Its ultimate goal is to evacuate advanced technology (from Point 103 in Canada) to Latin America, where:
- 3) The Reich *government* is in exile.

Once in South America, things take another very intriguing turn, for the novel's heroes "find support in Buenos Aires"²¹ and continue their travels onward to La Paz, Bolivia.

Once there, the hero Eyken lectures the others on the work of the real-life personage, Edmund Kiss. And as Goodrick-Clarke notes, Kiss's research

In Bolivia links up with new developments. Along the western side of the Andes mountains he discovered an extensive tunnel system stretching from the Atacama Desert as far as Ecuador, attributing it to a mysterious people with unimaginable technology many thousands of years ago.

And here, much to their Teutonic delight, Eyken and companions marvel at the "several hundred German military and scientific personnel" who "have established a secret base called Mime's Smithy as a companion to point 211 in Antarctica."²² As Goodrick-Clarke also notes, Mime is the figure of Norse mythology who forges Siegfried's sword, as popularized in composer Richard Wagner's opera *Das Rheingold*.

In any case,

Eyken and his comrades spend many months at this site, marveling at the advanced technology brought by German scientists who have escaped the American and Soviet dragnets for Third Reich miracle weapons researchers. Another, smaller secret base in the Andes has been established in the Brazilian forest near the Beni Valley.²³

Once again, we have the following elements:

- 1) a secret base or bases employing advanced technology;
- 2) in the remote environs of the Andes mountains, with
- 3) “hundreds” of German scientists and technicians who are
- 4) continuing to work on their advanced secret weapons projects, independently of Allied oversight and perhaps of Allied knowledge.

The clear implication of Landig’s second novel is that in spite of Russian and American attempts to corner the market on Nazi technology, *the best and most advanced of that technology eluded them, remained under more or less independent Nazi control, and continued to be developed by them* . And note one more thing: while in Buenos Aires Eyken and his companions receive “support.” This, as we shall learn in Part Three, is not only true, but true in a way that corroborates all four of the main points of Landig’s second novel! Clearly Landig has developed the implication of the two German surrenders, for in his first two novels, it is quite apparent that it is the Nazi party and its most-favored organization, the SS, that has survived and is overseeing these bases and technology.

3. Landig’s Third Novel: *Rebellen für Thule*

In his third novel, *Rebellen für Thule* (1991) Landig pulls the curtain back on the historical-esoteric connections underpinning all this independent and covert Nazi survival, and its continued development of exotic technology, for in it he traces the origin of the Black Sun concept back to ancient Babylonian religion.²⁴

This connection between the SS *Schwarze Sonne* (Black Sun) and Babylon was not merely wishful thinking on Landig’s part, for it formed part of mainstream German scholarship and Sumerology from the mid-nineteenth century, and the famous German Assyriologist Friedrich Delitzsch.²⁵ Delitzsch argued

That the Old Testament and Jewish monotheism were derived from Babylonian religion. His initial lecture, "Babel und Bibel" (1902),²⁶ aroused widespread controversy, as it clearly weakened Jewish claims of divine revelation and election. Taking the debate a stage further, Houston Stewart Chamberlain and Herman Wirth regarded Babylonian culture as a heritage of the Sumerians, whom they identified as early Aryan colonizers of Mesopotamia. Landig's interpretation of the Gilgamesh epic and inscriptions from Babylon follow this Nordic-Sumerian line by highlighting their correspondences to the Edda and old Norse sources.²⁷

The clear implication of Landig's assertions, following as it does the broad traditions of German Assyriological scholarship of the late nineteenth and early twentieth centuries, is that one of the main preoccupations of the SS was precisely the covert continuance of this tradition. Viewed in the wider context of his other novels, the implication is that there might be a connection between this esoteric preoccupation and the physics behind their continued black projects at their postwar bases.²⁸

C. Unusual "Corroboration": The Nazi UFO Myths and Baron Rudolf Von Sebottendorff

The esoteric connection between Nazism, high technology, and advanced aircraft was a part of the emerging "mythos" of Nazism within Neo-Nazi circles in the 1950s, the kernel of which was that "the flying disks were an important part of a German plan to create an extraterritorial state prior to a renewed attack on the Allied enemies after 1945....Nazi ufologists would recycle...and match Adamski's photographs with new 'discoveries' of wartime SS designs."²⁹ As Goodrick-Clarke notes, this mythos may reflect as much a moral palliative as an actual agenda, for "the fearful nature of the Third Reich and the burden of its defeat are thus deflected in a science fiction vision of German technical and racial superiority as the huge saucers rise about the brilliant white snows of an icebound Shanrgi-La"³⁰ that was located in Antarctica.

But there is a slight problem with Goodrick-Clarke's easy dismissal of the origins of the Nazi UFO mythos, for at approximately the same time as famous – or depending upon one's lights, infamous – UFO contactee George Adamski was publishing photos and films of his saucers and writing of his contact with blond-haired blue-eyed Nordic UFO occupants(!), a former Luftwaffe major, Rudolf Luser, published an astonishing book about German secret weapons, a brief section of which mentioned Nazi experimentation with jet-turbine flying saucers. Notably, the diagrams in Luser's book look nothing like the later alleged "discoveries" of flying saucer schematics allegedly drawn up under auspices of the SS.³¹ The timing of Luser's book and the Adamski sightings, while permitting the possibility of some small degree of influence between the two, makes it nevertheless unlikely, for Luser's "saucers", jet-propelled and clumsy-looking affairs that they are, hardly serve to corroborate the emerging Nazi UFO mythos.

There is also a deeper problem with Goodrick-Clarke's dismissal of the origins of the Nazi UFO mythos, and that is evident from an examination of the actual implications of his own remarks. As noted above, he believes that these flying saucers were, according to the mythos itself "an important part of a German plan to create an extraterritorial state prior to a renewed attack on the Allied enemies after 1945..."³² If one leaves the question of flying saucers out of view, and focuses on what they *represent*, then the Nazi mythos, according to Goodrick-Clarke, is making the following assertions:

- 1) There was a plan to create a postwar "extraterritorial" Nazi state, strongly suggestive in itself of a surviving postwar Nazi International *organization*; and,
- 2) Part of the original *planning* for that "extraterritorial" Nazi state included the continued development of the most advanced technology in the possession of the Third Reich by the end of the war.

Viewed in *this* way, the Nazi "flying saucer" myth is much more sobering in its implications.

However, there is a further esoteric connection to Sumer, Babylon, and ancient Persia, for some researching in the postwar Neo-Nazi circles made the claim that Thule Society founder Baron Rudolf Von Sebottendorff

Discovered old texts or oral traditions on his travels in the Middle East relating to (a) dualist rejection of El Shaddai (Jahve), the god of the Old Testament, whom Jesus identified as the devil (John 8:44).³³ Sebottendorff also allegedly found Persian and Babylonian references to a millennial battle between good and evil, which inspired his (spurious) book *Der interkosmische Weltenkampf* (1919). Sebottendorff was supposed to be acquainted with the prophecy of the “Third Sargon” by the Babylonian seeress Sajaha (c. 650 B.C.), which told of terrible woes and the inversion of all values until the avenging emperor would arrive from the north...and destroy all evil by fire.

As if that were not all, the same researchers – Jürgen-Ratthofer and Ralf Ettl – maintained that in August of 1917, the Baron and Hitler’s future geopolitics guru, General Karl Haushofer, the medium Maria Orsic, and a pilot named Lothar Weiz met

The old prelate Gernot of the Societas Templi Marconi at a café in Vienna. Their discussions turned on astrology and apocalyptic predictions in Indian, German, and Babylonian traditions. Gernot was highly impressed and invited Sebottendorff to visit the secret estate of his Templar order known as the “Die Herren vom Schwarzen Stein” (DHvSS) (Lords of the Black Stone) at Marktschellenberg in Bavaria. The DHvSS was supposedly founded by the Knight Commander Hubertus Koch in 1221 as a Marcionite³⁴ Templar order. Its dualist and Gnostic “Babylonian” doctrine told of the dominion of evil on earth and the battle between light and El Shaddai based on the revelations of the goddess Ishtar. The Black Sun is the divine source of energy accessible to initiates through a hierarchy of spiritual intermediaries. Through the DHvSS,

Sebottendorff understood that Marcionite anti-Judaist teachings ultimately came from the much older Babylonian doctrine common to all Aryan peoples. The cosmic challenge of the age demanded the defeat of El Shaddai and the Jews.³⁵

It was in fact Jürgen-Ratthofer and Ettl who first popularized the references to the mysterious “Vril” force in Neo-Nazi circles.

The “Vril” force, according to the new esoteric mythos, was the area of covert investigation of the so-called “Vril Society,” a society that was, in fact, first mentioned by the famous German rocket engineer Willy Ley,³⁶ who had fled to the United States to escape the Nazi regime. Ley maintained that such a society existed in Berlin, which raises the significant question: why would a rocket scientist know of a secret society in Berlin that was supposedly investigating the “Vril” force, the power of the aether, itself?

One answer is that

German researchers have recently established that such a group did exist in association with the astrological publisher Wilhelm Becker. This wholly obscure “Reichsarbeitsgemeinschaft ‘Das Kommende Deutschland’” published a short brochure *Vril: Die kosmische Urkraft* (1930), which described the Atlanteans as possessors of a spiritual “dynamo-technology,” superior to the mechanistic notions of modern science. Based on Vril energy, this technology also enabled the Egyptians and Aztecs to build their pyramids.... The group’s second brochure, *Weltdynamismus* (1930), rejected explosive technology and spoke of the release of *free energy*.³⁷

In other words, perhaps Ley had come upon the brochures in Germany and read them.

In any case, Jürgen-Ratthofer and Ettl elaborate their account even further, maintaining that the Vril Society was the esoteric offshoot of Von Sebottendorff’s Germanenorden (German Order), with its political branch becoming Sebottendorff’s Thule Society after World War One.³⁸ In their version, which was repeated in the much more widely circulated account of Jan Van Helsing,³⁹ a secret

meeting of Thule and Vril members was held in December of 1919 near Berchtesgaden. Here, the medium Maria Orsic

Presented transcripts in an old Templar script of communications she had received telepathically. These proved to be written in Sumerian, the language of the founders of the oldest Babylonian culture. These channeled communications came from the planet Sumi-Er in the solar system of Aldebaran, the brightest star in the constellation of Taurus.... Jürgen-Ratthofer and Ettl claim that the DHvSS and its modern successor, the Vril Society, received mediumistic confirmation that the Sumerians were a colony of superior beings sent from Aldebaran to earth 500 million years ago.⁴⁰

According to Jürgen-Ratthofer and Ettl, that is not all that Maria Orsic channeled, for she

Next received channeled instructions for the construction of a time-travel machine. A leading member of the Vril, Dr. W.O. Schumann, pioneered the development of electromagnetic fields through rotating disks, and a prototype was constructed near Munich in 1922....

In June 1934 Lothar Weiz flew the first RFZ 1 (Rundflugzeug) at Brandenburg. The stimulus of military innovation quickly led to highly advanced craft. Thereafter, the Thule Society took a hand by establishing the SS Development Department E-IV for advanced saucer technology.⁴¹

It would be easy to dismiss all these Neo-Nazi fantasies as the ravings of utter lunatics, were it not for a few uncomfortable facts.

Once again, if one removes all the fantastical elements and generalizes the concepts implicated in these assertions, one has the following assertions:

- 1) There was an advanced project, beginning some time in the 1920s in Germany, to control time and gravity. The date given is 1922, which is the same approximate time as the

publication of the first real hyper-dimensional unified field theory attempt to unify gravity and electromagnetism, the theory of German mathematician Theodor Kaluza;⁴²

- 2) This project was based on, or inspired and influenced in part by, reference to some sort of esoteric tradition, and its interpretation or “decoding” in terms of modern physics, as indicated by the presence of Dr. W.O. Schumann as an alleged member in the secret society attempting to construct this machine;
- 3) The principle in use in this machine was apparently rotating electromagnetic fields in disks, implying that more than one rotating electromagnetic field was in play; and,
- 4) This project later became a department of the SS, called the Development Area IV.

When viewed in this way, Jürgen-Ratthofer and Ettl’s assertions seem not so far-fetched, for as I detail in my previous books, there is a possibility that the Bell project itself may represent a a super-secret project begun, in fact, during the 1920s in Weimar Germany.⁴³ Moreover, there is a circumstantial case to be made that this project was influenced, in part, by the decoding of ancient esotericism in terms of modern physics.⁴⁴ And as anyone who has read my previous rationalizations of the Bell Project, its principle feature was probably high mechanical and electromagnetic rotation, allied with the employment of high voltage DC and AC potentials.⁴⁵ Finally, as I have also pointed out in my previous books, there was indeed an SS *Entwicklungstelle IV*, whose precise mission brief was the development of “free energy” technologies, that is, of technologies relying directly on the ability to draw energy from the physical medium.⁴⁶

To put it succinctly, all four of the basic implications of Jürgen-Ratthofer’s and Ettl’s assertions are in fact *true*.⁴⁷

D. The Curious Incident: Reinhard Schmidt’s Contact with German-Speaking UFO Occupants

As if to reinforce all this high strangeness surrounding Nazis and UFOs, a Nebraska farm broker and German-American, Reinhold O. Schmidt, had a extremely unusual UFO encounter. He claimed to have been contacted by occupants of a cigar-shaped UFO who spoke German! Of course, contactees all over the world report hearing such alleged occupants as speaking their own language or of communicating with humans “telepathically,” so there is nothing unusual or significant in this fact alone. However, for *his* efforts, Mr. Schmidt was rewarded with a stint in a psychiatric clinic. Furthermore, in an article in a West German newspaper reporting the incident, the U.S. Air Force was apparently somewhat concerned about the event.

1. Reinhold O. Schmidt's Actual Account

Schmidt's actual account of his contact, however, deserves closer scrutiny, for it is divided into two distinct parts, the first dealing with his *initial* contact, and the second, dealing with subsequent contacts. Reading the second part of Schmidt's own account would convince anyone that the man may have been more than a little “out there,” as he recounts journeys with his German speaking space-brothers to Russia, the North Pole (where he is feted to an early lecture on the dangers of global warming!), and to the Great Pyramid of Giza where the leader of the space-brothers, a “Mr. X,” uses a laser-beam-like device to gain entry into secret chambers inside the structure.

„Marsmenschen“ sprachen deutsch

Geschäftsfahrt eines kalifornischen Händlers — US-Luftwaffe alarmiert

Washington (UP). Das Radarnetz der amerikanischen Luftwaffe ist in Alarmbereitschaft versetzt worden, um auf sogenannte „nicht identifizierte Flugkörper“ zu achten. Bisher wurden aber keine derartigen Gegenstände registriert, teilte ein Sprecher mit. Inzwischen gehen bei amerikanischen Dienststellen immer neue Berichte ein, in denen von der Beobachtung unbekannter Flugkörper, die meist wie Zeppelina ausgesehen haben sollen, die Rede ist.

Einem kalifornischen Getreidehändler namens Reinhold Schmidt ist, wie er erzählt, der Vorzug zuteil geworden, ein derartiges Raumschiff betreten zu dürfen und mit seinen Insassen gesprochen zu haben. Auf einer Geschäftsfahrt stieß Schmidt nach seinem Bericht auf ein silbernes glänzendes Ding, das wie eines der kleinen Luftschiffe der US-Kriegsmarine aussah. Es sei über dreißig Meter lang, zehn Meter dick und etwa fünf Meter hoch gewesen. Als er noch 20 Meter von dem „Raumschiff“ entfernt gewesen sei, habe sein Wagen den Dienst versagt.

Schmidt sagte, er sei aus seinem Wagen gestiegen und auf das Ding zugegangen, das auf vier Pfählen ruhte. Dann wurde eine Treppe ausgefahren. Zwei Männer seien erschienen und hätten ihn angeleuchtet. Für eine Sekunde habe er sich nicht rühren können. Dann sprachen die beiden Männer, erzählte Schmidt. Anstelle der Marsprache, die er erwartet haben mochte, will er aber Deutsch und Englisch mit deutschem Akzent vernommen haben.

„Wir haben hier eine kleine Weile zu tun — warum wollen Sie nicht hereinkommen?“, fragten die „Raumfahrer“ nach Schmidts Angaben. Er sei der Einladung gefolgt und habe im Innern des Flugkörpers noch zwei Männer und zwei Frauen getroffen. Er sei durchsucht worden und nach 20 Minuten angeregter Unterhaltung habe er die Flugmaschine verlassen, die dann lautlos aufgestiegen sei. „Sie werden

Donnerstag, 7. November 1957

später erfahren, was wir hier tun“, hätten die Besatzungsmitglieder noch zu ihm gesagt.

Nach den Polizisten, Soldaten und Autofahrern, die bereits vor Tagen mysteriöse Flugkörper gesehen haben wollen, hat sich jetzt ein Radio-Ingenieur gemeldet, der in der Nähe des amerikanischen Raketenversuchsgeländes in New Mexico ein eiförmiges Flugobjekt gesehen haben will.

Samstag, 9. November 1957

Vom Raumschiff in die Nervenklinik

Kearney (USA). (UP). Reinhold Schmidt, der am Anfang der Woche mit seinem Bericht über den Besuch in einem Raumschiff großes Aufsehen erregte, ist inzwischen von den Gesundheitsbehörden Nebraskas für unbestimmte Zeit zu „Beobachtung und Behandlung“ in eine Nervenklinik eingewiesen worden. Zwei Psychiater halten nach einer gründlichen Untersuchung festgestellt, daß Schmidt nicht als Betrüger anzusehen sei, sondern daß er offenbar wirklich daran glaube, ein Raumschiff gesehen und es auf Einladung der Besatzung besichtigt zu haben.

German Newspaper Articles About Reinhard Schmidt's Contact with German-Speaking UFO Occupants and His Subsequent Hospitalization in a Psychiatric Clinic. Note the Reference to the Alarm of the U.S. Air Force

But the first part of his short autobiographical account of his initial contact, “The Reinhold O. Schmidt Story: Cosmic Secrets Exposed: Edge of Tomorrow: The True Account of Experiences with Visitors from Another Planet,” presents a far more sobering picture, for it details his initial contact with six German-speaking UFO occupants near Kearney, Nebraska on November 5, 1957.⁴⁸ Schmidt's account

has about it the air of plausibility for two reasons, the first being that he was a very careful observer of what he saw. And the second because what he saw was clearly technological, but a technology *not exotic enough to compel to the conclusion that it originated off this planet.*

a. The Malfunctioning Ignition and a Nazi and Fascist Parallel

Schmidt begins by noting that after seeing a brilliant flash of light while driving back from work during the night, that his “car engine suddenly stopped.” He “turned the ignition off and on several times” but to no avail.⁴⁹ Malfunction of automobile electrical systems is, of course, a common feature of UFO encounters, and can be rationalized on the basis of conventional science as the result of an electromagnetic pulse or exposure to strong electromagnetic fields that basically “short out” electrical equipment in their vicinity.

But as I have also pointed out in my previous book *Secrets of the Unified Field*, such devices were allegedly part of the secret weapons projects both of Fascist Italy and of Nazi Germany.⁵⁰ Thus, the conjunction of German-speaking occupants of Schmidt’s UFO and its strange effects on his car serve to mutually corroborate the speculative possibility that Schmidt encountered some postwar descendant of those wartime secret projects. Schmidt’s encounter “with beings from another world” can, in short, be scientifically rationalized by terrestrial technological antecedents.

b. The Pencil Thin Beam of Light

Schmidt then recounts that, having failed to turn his automobile engine back on, he exited his car and raised the hood, thinking perhaps that a wire had come loose. As he did so, he noticed a large craft that looked like a “half-inflated balloon” but which was made of metal, and which rested on “four hydraulic rams serving as landing gear.” As he drew near the object,

A thin stream of light, about as big around as a pencil, shot out from it and hit me across the chest. It seemed as if I were

suddenly paralyzed; I could not move. Maybe I was only scared stiff but, before I could analyze my feelings, a door in the ship slid open and two *men* came out of it toward me.⁵¹

Again, one notes the resemblance of Schmidt's technological description of the pencil thin beam of light to a piece of wholly terrestrial technology that would become public knowledge in a few short years: the laser. While Schmidt is clear that his paralysis might have been his own emotional and physiological response to this, it is also clear that he implies that it was the result of being struck with the beam. While such a paralysis-inducing technology would have been extraordinarily sophisticated for the day, it is now known that the American military and intelligence services were working on methods of mind manipulation via technological and pharmaceutical means during the same time frame. One need only think of the CIA's MK-Ultra project in this connection. Again, while sophisticated for the day, nothing in Schmidt's account thus far compels to the conclusion that his alleged encounter, if indeed it took place, represented contact with an extraterrestrial race, civilization, or technology.

c. *"Inside the Ship"*

Shortly after this, Schmidt describes being invited into the ship by the leader of its six occupants, a man he calls "Mr. X" and whom he describes as speaking "English with a German accent."⁵²

Besides the leader, there were three men and two women in the ship. The women were sitting behind a big desk on which there was a large frame which enclosed what looked like a viewing screen. At the same end of the ship were four columns for colored liquid: red, green, blue and orange. These tubes were approximately 4 and one half feet high and 6 inches in diameter. The ladies seemed to be watching the liquid very closely as it moved slowly up and down, like the pistons in an automobile. The three men were working on an instrument panel that filled one side of the room. I saw one of them clipped off some short wires. The panel was filled with clocks, dials,

buttons and switches. In the center was a large screen which looked like our television screens, but it was not working while I was there.⁵³

Wires, tubes, dials, clocks, switches, and colored liquid, being monitored by a crew of “men” and “women.” Schmidt’s language is not evocative of advanced extraterrestrial technology, and in fact serves to underscore the possibility that Schmidt actually *did* encounter what he describes.

As if to underscore this even further, Schmidt even makes a fascinating (and disturbing) observation about the “instrument panel” itself:

(It) had no name or identification which might have disclosed the place of manufacture, but I did notice some Arabic numerals and some Roman numerals on it. However, there were no other figures or letters of any kind on either the inside or the outside of the ship.⁵⁴

One would hardly expect, on an “advanced extraterrestrial craft” to encounter Arabic and Roman numerals! Again, there is nothing exotic enough about the technology described to compel toward the conclusion that Schmidt had encountered something extraterrestrial in origin.

In fact, the exact *opposite* is the case. He had encountered something extraordinary, to be sure, but extraordinary precisely because every detail he elicits only serves to emphasize its human origins! Even Schmidt’s descriptions the odd way that the occupants seemed to *glide* rather than *walk* can be wholly rationalized on the basis of a now well-known terrestrial technology, for most of those reading this book will have encountered teenagers gliding along a sidewalk or pavement on tennis shoes equipped with roller wheels!⁵⁵

As if to highlight all the high strangeness of this unusual UFO contactee story, Schmidt makes the following observation:

When these people spoke among themselves they used high German, which I happen to understand, as I graduated from a

school in which both German and English were taught. I could speak, read, and understand it fairly well. But these people all spoke to me in English with a German accent.⁵⁶

Schmidt, normally so careful an observer during the first part of his account does not seem to ask nor answer the obvious questions: What were they talking about? Why did they assume he did not speak German? And most importantly, Why were they speaking *German*? Why not Russian? French? Mandarin Chinese or Swahili? Why *German*?

The implications of his assertions never seem to have occurred to him, but they are clear, if true: he had witnessed some exotic terrestrial technology clearly tied to Germans and Germany...

d. An Interesting Interest and Intriguing Observation

At this juncture, Schmidt then recounts how the leader, “Mr. X,”

Asked me if I knew anything about the United States’ satellite program. When I replied that I did not, he said, “They’re planning to send up some satellites, but the first two will never leave the ground. The third will go up, but it won’t send back data.”

This prophecy has since proved true. The results of those flights were printed in newspapers all over the country.⁵⁷

True enough, but once again the extraordinary implications of Schmidt’s story seemed to have escaped him, for America’s satellite program at that point in history was highly classified. How then did Schmidt’s UFO occupants know about it? And more importantly, how did they know in advance what would happen with the first flights? Schmidt’s “Mr. X” clearly has access to some inside knowledge...

e. Departure

When the craft’s crew finished whatever preparations they had been engaged in, they informed “Mr. X”, once again in German, that

they were ready, and at this point “Mr. X” informed Schmidt that he had to leave.

As I stepped onto the ground, the motor started. It sounded like a large electrical one, and it became quieter as it worked up momentum. It ran a few seconds and then the ship took off... straight up in the air! About 12 feet off the ground it turned pitch black. Then at about 100 feet it turned a bluish-green and headed southwest. There was a brilliant flash, and then the ship absolutely disappeared before my eyes! I estimated the ceiling of the clouds that day to be only about 800 feet, but the ship had vanished at about 150 feet. A county official told me later that the craft had stalled a tractor, two cars, and a large truck... all of which had been beneath the path of the ship during its takeoff.

During my first visit aboard the strange craft I had been told not to try to start my car until the ship was out of sight, and that an attempt to do so would be unsuccessful. Now I realized why my car had stalled earlier when I first approached the ship.⁵⁸

Other UFO contact reports, of course, record similar features, but what is noteworthy here is that Schmidt describes a similar sight as witnesses describing the outdoor testing of the Nazi Bell device.⁵⁹ And as I point out in my book *Secrets of the Unified Field*, one and the same science can be used as a basis to explain and rationalize both the celebrated Philadelphia Experiment and the alleged invisibility of the U.S. destroyer escort *Eldridge* as well as the Nazi Bell.⁶⁰ It is perhaps expedient to also point out that the Bell used a heavy maroon-violet *liquid* in the device, a fact loosely paralleled by the implications of Schmidt’s observations of four colored liquids inside the UFO.

f. The Authorities Get Involved

Schmidt quickly returned to Kearney where he informed a local deputy sheriff of the whole episode. After the deputy informed Schmidt that an earlier siren during the daytime was because a local resident also reported seeing a “strange object in the sky,”⁶¹ Schmidt

and the deputy returned to the spot along the Platte River where he had experienced his encounter. There they noticed the imprints of the “four hydraulic rams on the dry bed of the Plate River” and some oil of a dark green color, “fine textured and sweet smelling.” Schmidt notably remarks that he “could not be positive that it had come from the ship.”⁶² The two men returned to Kearney and reported it all to the local chief of police.

The police chief then contacted the City Attorney and a local newspaper reporter, and the three men along with Schmidt and the deputy returned to the site in a police cruiser “with the siren going full blast all the way!”⁶³ The four imprints of the landing gear legs were still visible, as was the dark green oil. The deputy and Schmidt stepped off the distance between the landing gear imprints and “we estimated that the ship had been about 100 feet long and 30 feet wide. I guessed its height to be about 14 feet.”⁶⁴ Gathering up some of the oil for analysis, the group returned to Kearney, where Schmidt returned to his motel to watch television in the lobby.

While watching a local program it was suddenly interrupted by a news flash stating that a “spaceship” had landed at Kearney, Nebraska. Schmidt’s reaction to this announcement is significant:

I was very much surprised because nothing had been said to me about making an announcement over the air. *In fact, I had not even referred to the object as a spaceship, because I didn’t know what it was.* I thought that perhaps it might have come from Russia, and that it was manned by a crew of German scientists getting data on the first Russian Sputnik which had been launched about a week before.⁶⁵

In other words, *Schmidt’s own original inclination was to interpret the craft as something **wholly terrestrial.***

And not only that.

The story had begun to change.

g. Schmidt Arrested and Committed

At this juncture, Schmidt records events that clearly indicate that someone, somewhere, did not like what they were hearing coming out of Kearney, Nebraska, and that they took immediate steps to discredit both Schmidt and his story.

...I had become aware of the change in the manner of the officials as they discussed my experience. Not only that, but the story they were now telling no longer sounded the same at all!

Suddenly, about 6:00 a.m. they asked me to say that my experience had not happened at all, and that it was a lie! They even asked that I change my story to match theirs! I was dumbfounded at this turn of events. I told them that they could tell whatever story they wanted to, but that I would not change mine unless the truth would jeopardize the security of the United States. They had no answer for that!⁶⁶

After refusing to submit to a lie detector test unless the authorities did as well, Schmidt was informed by the chief of police that he would be held in jail – without a warrant.⁶⁷

The next morning, the City Attorney visited Schmidt to inform him that they had discovered a half full can of dark green motor oil in the trunk of his car along with an oil funnel, proving that his story was made up.

I told him that he would have to think of a better one than that. I brought to his attention the fact that the cans which he had showed (me had) circular holes, and that the can opener I carried in my car cut a triangular hole. Also, the two cans in question were the Veedol brand. The oil cans I carried then (which are in my car), are RPM and Skelly.⁶⁸

As if to highlight the possibility that the local authorities were being pressured to railroad Schmidt through such clumsy evidence planting efforts, Kearney received two more distinguished visitors:

Two Air Force officials had arrived in Kearney during the night from Colorado.

(That was fast!)

The next morning about eleven o'clock, November 6th, I was taken over to the police station to talk with them. They recorded my whole experience on a tape as I told it to them. During this session, one of the Kearney officials happened to wonder out loud just how the ship could go straight up when it took off. One of the Air Force men forgot himself for a moment and admitted, "Oh, we know all about that."⁶⁹

Given what has been cited thus far, we are permitted to speculate what happened.

Schmidt, after he had repeated his story to the local Chief of Police, and after the latter and other local officials had verified the story by checking out the landing site, was ordered to be held by the Air Force until they could arrive on the scene and investigate firsthand. In all likelihood the local authorities, after hearing Schmidt's story – and particularly the detail about the German speaking occupants – had probably contacted the nearest Air Force base to Kearney, which at that time was most likely Offut Air Force Base south of Omaha, at that time also the headquarters of the Strategic Air Command. Offut then most likely contacted The North American Air Defense Command in Colorado Springs. While NORAD would not be officially founded until May 12th of the following year, most likely a skeletal command structure was already in place in Colorado. At any rate, regardless of how the contact between local officials and the Air Force was actually made, the fact remains that the Air Force showed up very quickly, and doubtless exercised a great deal of influence in what happened next to Schmidt, for he found himself hauled before a mental competency board on November 7th, and committed to a psychiatric hospital in Hastings, Nebraska.⁷⁰ After intervention from his employer and family who both attested his mental worthiness, Schmidt was finally released.

But the damage had been done: Schmidt's story, which he refused to retract in spite of pressures to do so, was discredited.

And this raises the possibility that the *rest* of Schmidt's accounts of subsequent encounters – which partake so little of the same matter-of-fact character as the first half of his story, and which include many spectacular and far-fetched elements – was itself deliberately concocted under pressure precisely in order to discredit the first part.

Whatever one makes of the Reinhold Schmidt contact affair, however, three things stand out as significant for our purposes:

- 1) It was a story with a clear statement of contact with German speaking occupants of a UFO;
- 2) That UFO represented a technology clearly terrestrial, as evidenced by Schmidt's own descriptions of it, of its human operators, and of the very human identifiers of "Arabic" and "Roman" numerals on some of its equipment, and as well by Schmidt's own inclination *not* to identify it as an extraterrestrial spacecraft but as *Russian* in origin; and,
- 3) The U.S. Air Force clearly was concerned about the story, since it took self-evidently strong but covert measures to pressure Schmidt to change his story, and when that failed, by discrediting it by having him involuntarily committed to a psychiatric hospital. In this respect, the U.S. military's reaction to Schmidt's story is of a piece to its reaction to Roswell, which as I have speculated in my books *Reich of the Black Sun* and *The SS Brotherhood of the Bell*, may have been the crash of something exotic, terrestrial, and *Nazi*, for the crash of such a craft, able to enter sensitive American airspace with impunity, *would* have sent the American military into a tailspin of panic, for it meant that someone on earth was continuing a line of development of wartime Nazi technology independent of any of the victorious Allies.⁷¹

It is as if Reinhold Schmidt had either concocted a fictitious, or participated in an actual, event to corroborate the assertions of Wilhelm Landig's science fiction novels. There is just one problem... they hadn't been written yet.

2. *The Rosin Affidavit: An Interpretive Context*

All this casts the affidavit of Dr. Carol Rosin, long-time American associate of Nazi Paperclip rocket scientist Wernher Von Braun, into a new light. Rosin claimed that Von Braun told her that prior to his death in 1973 the world's elite had a long-range plan for the control and manipulation of the population in response to various "perceived enemies:"

The strategy that Werner Von Braun taught me was that first the Russians are going to be considered the enemy... Then terrorists would be identified, and that was soon to follow... Then we were going to identify third-world country "crazies." We now call them Nations of Concern. But he said that would be the third enemy against whom we would build space-based weapons. The next enemy was asteroids. Now, at this point he kind of chuckled the first time he said it. Asteroids – against asteroids we are going to build space-based weapons. And the funniest one of all was what he called aliens, extraterrestrials.⁷²

In the light of the foregoing discussion, however, Von Braun's alleged statements not only begin to acquire the ring of truth, but also raise the specter that he "knew something" from long ago, something connected with the secret projects under way in Nazi Germany. His remarks to Rosin raise the distinct possibility that any such massive "ET" contact will in fact be a massive *deception* planned and orchestrated by humans, and based upon exotic though quite secret technology, and made in aid of a sinister ideology: Nazism.

E. Conclusions

So what do we have?

In the first instance, the Allied failure to demand a representative of the Nazi Party to surrender, and their failure to demand that it abolish itself, afforded a clear loophole, not only legally, but more importantly, imaginatively, for the postwar neo-Nazi movement to claim, on the basis of that omission, that the Party had survived the war, battered to be sure, but intact.

In the fertile soil of that opportunity, aspects of the original esoteric influences at work within the Party and more particularly, within Himmler's SS grew to encompass the myth of Nazi survival, and to elaborate it – as attested by Landig's novels – with a detail breathtaking and fantastic in its scope and particulars. This elaboration, as was seen, included the following assertions:

- 1) That the Reich government survived the war and that the Nazi Party had never surrendered;
- 2) that it based itself in Latin America;
- 3) that secret bases were maintained, staffed by German scientists and former SS and military personnel; in remote polar regions and remote areas of the Andes mountains;
- 4) that these bases also continued to pursue a line of technological and scientific development of exotic technology tied to advanced propulsion and aircraft (i.e., flying saucers), free energy, and the “ultimate doomsday weapon”;
- 5) that the organization had *internationalized* Nazism while retaining a solidly German core, but welcoming new ethnic elements, particularly Muslim Arabs and various Oriental groups; and finally,
- 6) that the geopolitical agenda of this group was to create a third bloc of nations in distinction to the two superpowers in conjunction with the creation of an extraterritorial Nazi “state,” and that the continued independent development and monopolization of the above-mentioned advanced technology was crucial to that geopolitical agenda.

As Landig indicated in the subtitle of his first novel, its main plot was “full of realities” (*voller Wirklichkeiten*). How many of these “realities” are true, and to what extent, is the subject of the rest of this book.

And the answers are not only surprising, but indeed supremely unsettling...

¹ Anthony Sutton, *Wall Street and the Rise of Hitler*, http://reformed-theology.org/html/books/wall_street/introduction.htm, p. 1.

² For the Allied Legend of Nazi nuclear incompetence. see my *Reich of the Black Sun* (Kempton, Illinois: Adventures Unlimited Press, 2004), pp. 3-158.

³ See, for example, the “research” of the Institute for Historical Review.

⁴ And they did recognize it de facto, since it was Dönitz’s radio broadcast of the surrender and his orders to the German Wehrmacht to cease hostilities, that in fact performed the obligations of the surrender terms.

⁵ Hitler had, before the war succeeded President Paul Hindenburg as “Reichspräsident” by passing a law that combined the offices of president and chancellor into that of Führer. In his last political will and testament, Hitler recreated the office of Reich President, while devolving the office of chancellor upon Nazi propaganda minister Josef Göbbels. What exactly this arrangement was supposed to mean was rather nebulous, but in the context of the Weimar constitution, the constitution under which the Nazi state came into existence, it gave Dönitz the real control of the government, since as President he could dissolve the Reichstag (a formality in any case, since it had long since ceased to function), and appoint the Chancellor. Hitler also appointed Dönitz as *Staatsoberhaupt* or Supreme Head of State, thus empowering him to conduct the foreign affairs of the Reich. More importantly, Hitler also named Dönitz as his successor as *Oberbefehlshaber der deutschen Wehrmacht*, Supreme Commander of the German Defense Force. In such capacities, then, Dönitz was empowered to conduct foreign policy, to conclude the surrender of the German Armed Forces, and order that they cease operations and disarm.

⁶ Nicholas Goodrick-Clarke, *Black Sun: Aryan Cults, Esoteric Nazism, and the Politics of Identity* (New York University Press, 2002), pp. 128-129.

⁷ *Ibid.*, p. 129.

⁸ *Ibid.*

⁹ *Ibid.*

¹⁰ See Tom Agoston’s *Blunder! How the U.S. Gave Away Nazi Super Secrets to Russia* (1985), p. 12 in conjunction with David

Hatcher Childress and Renato Vesco, *Man-Made UFOs* (Adventures Unlimited Press, 1994), pp. 134-176. See also Henry Stevens, *Hitler's Suppressed and Still-Secret Weapons, Science, and Technology* (Adventures Unlimited Press, 2007), pp. 198-208 for the involvement of I.G. Farben in laser research at Ludwigshafen. This is yet another piece of data to add to the case I made in my book *The Philosophers' Stone* (Feral House, 2009), pp.205-254 that the Nazis were involved in tunable dye laser research for isotope enrichment.

¹¹ Goodrick-Clarke, *Black Sun*, p. 137.

¹² Ibid., p. 129.

¹³ See my *SS Brotherhood of the Bell*, pp. 389-393.

¹⁴ Goodrick-Clarke, *Black Sun*, p. 137.

¹⁵ See my *The Philosophers' Stone* (Feral House, 2009), pp. 255-294..

¹⁶ Ibid., pp. 359-368.

¹⁷ See Jim Marrs, *The Rise of the Fourth Reich* (2008), pp. 92-105.

¹⁸ Himmler's sponsorship may have extended beyond the known Schäffer expedition of 1938-1939, as several Tibetan monks were found by Russian forces entering Berlin at the end of the war. The monks, allegedly, were in SS uniforms and had committed ritual suicide. However, no monks were brought out during the Schäffer expedition of 1939-39. It is known that Schäffer's team brought out an entire priceless copy of the ancient Tibetan epic collection, the *Kang Schuur*, and this most likely would have required Tibetan assistance in translating the work. I speculate, therefore, that at some point during the war, most likely after the German invasion of Russia, that another secret SS expedition was undertaken to Tibet with SS commandos who, once there, built an airfield for German long-range aircraft which in turn flew the monks back to Germany. The most likely time for such an expedition to have occurred would have been during the German long-range armed reconnaissance to Astrakhan on the Caspian Sea during the big German offensive in Russia during the summer of 1942.

¹⁹ Goodrick-Clarke, *Black Sun*, pp. 137-138.

²⁰ Goodrick-Clarke, *Black Sun*, pp. 142-143.

²¹ Ibid., p. 143.

²² Goodrick-Clarke, *Black Sun*, p. 144.

²³ Ibid.

²⁴ Goodrick-Clarke, *Black Sun*, p. 147.

²⁵ This is the same Friedrich Delitsch of the famous Keil and Delitsch series of extensive biblical commentaries, a standard scholarly reference.

²⁶ I.e., “Babel and Bible.”

²⁷ Goodrick-Clarke, op.cit., p. 147.

²⁸ See also my book *Reich of the Black Sun* (Adventures Unlimited Press, 2004), pp. 161-179, and my book *The Philosophers’ Stone* (Feral House, 2009), pp. 259-293 for further explorations of the theme of the connection between Nazi esotericism and physics.

²⁹ Goodrick-Clarke, *Black Sun*, p. 155.

³⁰ Ibid., p. 157.

³¹ These later designs include the notorious – and in my opinion utterly spurious – Hannebu and Vril flying saucers.

³² Goodrick-Clarke, *Black Sun*, p. 155.

³³ For a possible Sumerian context from which to view this interpretation, see my *The Cosmic War: Interplanetary Warfare, Modern Physics, and Ancient Texts* (Adventures Unlimited Press, 2007), pp. 302-303.

³⁴ Marcionism was an early Christian heresy that taught that the God of the Old Testament could not have been the Father of Christ, since he was entangled with the material world, which in the dualist thinking common to the pagan culture of the age, was tainted with evil. Any god thus entangled with matter was perforce to that degree evil.

³⁵ Goodrick-Clark, *Black Sun*, p. 165.

³⁶ Ibid., p. 166.

³⁷ Ibid., emphasis added.

³⁸ Goodrick-Clarke, *Black Sun*, p. 166.

³⁹ See my *SS Brotherhood of the Bell*, pp. 104-115.

⁴⁰ Goodrick-Clarke, *Black Sun*, p. 166.

⁴¹ *Ibid.*, p. 167, emphasis added.

⁴² See my *Secrets of the Unified Field: The Philadelphia Experiment, The Nazi Bell, and the Discarded Theory* (Adventures Unlimited Press, 2008), pp. 1-17.

⁴³ See my books *The SS Brotherhood of the Bell: NASA's Nazis, JFK, and MAJIC-12* (Adventures Unlimited Press, 2006), pp. 1-17, 282-288, and my *The Philosophers' Stone: The American "Gold," The Soviet "Mercury," and the Nazi "Serum,"* (Feral House, 2009), pp. 282-293.

⁴⁴ See my *Secrets of the Unified Field: The Philadelphia Experiment, The Nazi Bell, and the Discarded Theory* (Adventures Unlimited Press, 2008), pp. 262-288, and my *The Philosophers' Stone: The American "Gold," The Soviet "Mercury," and the Nazi "Serum,"* (Feral House, 2009), pp. 255-293.

⁴⁵ See my *SS Brotherhood of the Bell*, pp. 141-191; *Secrets of the Unified Field*, pp ; and *The Philosophers' Stone*, pp 268-288.

⁴⁶ See my *SS Brotherhood of the Bell*, pp. 144-148; and my *The Philosophers' Stone*, pp. 198-201.

⁴⁷ There is another assertion made by Jürgen-Ratthofer and Ettl in the quotations cited above, and this is that the original contact between "Aldebaran" and earth occurred some 500 million years ago between humanity and human-like beings from that star system. In other words, they maintain the antiquity of humanity as an implied explanation for the sophistication of the culture and civilization that pre-dated the classical civilizations of Sumer and Egypt. For this implication of ancient texts and their assertions of such contact, see my *The Cosmic War: Interplanetary Warfare, Modern Physics, and Ancient Texts* (Adventures Unlimited Press, 2007), pp. 399-409.

⁴⁸ Reinhold O. Schmidt, "The Reinhold O. Schmidt Story: Cosmic Secrets Exposed: Edge of Tomorrow: The True Account of Experiences with Visitors from Another Planet," <http://galactic.to/rune/reinhold.html>, p. 1.

⁴⁹ Reinhold O. Schmidt, "The Reinhold O. Schmidt Story: Cosmic Secrets Exposed: Edge of Tomorrow: The True Account of

Experiences with Visitors from Another Planet,” <http://galactic.to/rune/reinhold.html>, p. 2.

⁵⁰ Joseph Farrell, *Secrets of the Unified Field*, pp. 239-248.

⁵¹ “The Reinhold O. Schmidt Story: Cosmic Secrets Exposed: Edge of Tomorrow: The True Account of Experiences with Visitors from Another Planet,” <http://galactic.to/rune/reinhold.html>, p. 2, emphasis added.

⁵² Ibid.

⁵³ “The Reinhold O. Schmidt Story: Cosmic Secrets Exposed: Edge of Tomorrow: The True Account of Experiences with Visitors from Another Planet,” <http://galactic.to/rune/reinhold.html>, p. 2.

⁵⁴ Ibid., p. 3.

⁵⁵ Ibid.

⁵⁶ “The Reinhold O. Schmidt Story: Cosmic Secrets Exposed: Edge of Tomorrow: The True Account of Experiences with Visitors from Another Planet,” <http://galactic.to/rune/reinhold.html>, p. 3.

⁵⁷ Ibid.

⁵⁸ “The Reinhold O. Schmidt Story: Cosmic Secrets Exposed: Edge of Tomorrow: The True Account of Experiences with Visitors from Another Planet,” <http://galactic.to/rune/reinhold.html>, p. 3.

⁵⁹ See my *SS Brotherhood of the Bell*, pp. 185-186.

⁶⁰ See my *Secrets of the Unified Field*, esp. pp. 165-190; 269-282.

⁶¹ “The Reinhold O. Schmidt Story: Cosmic Secrets Exposed: Edge of Tomorrow: The True Account of Experiences with Visitors from Another Planet,” <http://galactic.to/rune/reinhold.html>, p. 5.

⁶² Ibid.

⁶³ Ibid.

⁶⁴ Ibid.

⁶⁵ “The Reinhold O. Schmidt Story: Cosmic Secrets Exposed: Edge of Tomorrow: The True Account of Experiences with Visitors from Another Planet,” <http://galactic.to/rune/reinhold.html>, p. 5, emphasis added.

⁶⁶ Ibid., p. 6.

⁶⁷ “The Reinhold O. Schmidt Story: Cosmic Secrets Exposed: Edge of Tomorrow: The True Account of Experiences with Visitors from Another Planet,” <http://galactic.to/rune/reinhold.html>, p. 6.

⁶⁸ Ibid., p. 7.

⁶⁹ Ibid.

⁷⁰ “The Reinhold O. Schmidt Story: Cosmic Secrets Exposed: Edge of Tomorrow: The True Account of Experiences with Visitors from Another Planet,” <http://galactic.to/rune/reinhold.html>, p. 7-8.

⁷¹ See my *Reich of the Black Sun*, pp. 274-330 and my *The SS Brotherhood of the Bell*, pp. 311-384.

⁷² Cited in Steven M. Greer, M.D., *Disclosure: Military and Government Witnesses Reveal the Greatest Secrets in Modern History* (Crozer, Virginia, 2001), pp. 255-256.

✘ 2 ✘

There's Nazis in the Bushes: The Pattern of Prewar Corporate-Nazi Cooperation

*“It was rumored that the trial transcripts of the 1942
prosecution of
Prescott Bush were destroyed in the September 11, 2001,
collapse of
World Trade Center 7, which housed the offices of the Securities
and
Exchange Commission. “*
Jim Marrs¹

In 2003, the BBC, *The New York Times*, and other major media organs around the world, ran stories about a corporate bankruptcy. While not unusual in and of itself - after all, corporate bankruptcies often make front page news or lead stories in broadcasts - what was unusual about this bankruptcy, or rather, forced liquidation, was that it had been in the courts for fifty-one years! And that raises a rather obvious question: What corporation could be, or as the case may be, *could have been*, so large and so powerful that it would take fifty-one years to complete? Not even A.T.& T., “Ma Bell,” took *that* long!

The corporation's name, however, says it all, for people who know its history, for it was the notorious *Interessen-Gemeinschaft Farbenindustrie, A.G.*, better known as I.G. Farben, the gargantuan German chemicals cartel that was *broken up* at the end of World War Two into the “little” firms of Hoechst, Bayer, BASF (*Bayrischen Anilin und Soda-Fabrik*), and AGFA (*Aktien-Gesellschaft für Anilin*

Fabrikation), each of which was and is a large “multinational” corporation in its own right. The fact that the components of I.G. Farben are so big gives an indicator of the size and power of the enormous Farben cartel.

Farben was, by anyone’s reckoning, *the* corporation that ran Nazi Germany’s enormous “military-industrial complex.”

But size and power alone do not by themselves account for the extraordinarily long time it took to finally be rid of the corporation. There are other factors involved, one of which is the amount and type of compensation I.G. Farben or its successors would pay its victims or their families for the Holocaust. Unfortunately, in the world of multi-national corporate amorality and greed, this factor played a small role.

A much larger role was played by I.G. Farben’s prewar cartel and patent licensing contracts with foreign corporations in the United Kingdom, France, and the United States, and in that, as they say, lies an important story, for it is in the outlines of those arrangements and agreements that one may also discern the form and shape that the Nazis’ postwar survival plans would follow. And Farben’s system of cartel and license agreements also became in the prewar period part of a much larger pattern of international corporate cooperation between Nazi Germany and the Western Powers, particularly the United States. Hence, to understand the Nazi postwar survival plans, it is necessary to have an understanding of that prewar pattern.

A. Wall Street and the Rise of Hitler`

It was a former Hoover Institute scholar and fellow turned conspiracy-theory-researcher, Anthony Sutton, whose trilogy of books, *Wall Street and the Rise of FDR*, *Wall Street and the Rise of the Bolsheviks*, and *Wall Street and the Rise of Hitler*, documented the existence of a powerful international corporate elite, based in America, that was “fundamentally significant in the determination of world affairs, at a level far behind and above that of the elected politicians.”² Beginning with his work for the Hoover Institute, when Sutton was still a respected member of the academic community, he began to notice a curious fact about Soviet-American relations,

namely, that the best American technology was being quietly shifted to the Soviet Union through dubious trade agreements between the Russian Government and various American corporations. America was, in short, arming its enemy, and this was by deliberate design! Sutton published a lengthy technical report for the Hoover Institute, and popularized his findings in a book titled *The Best Enemy Money Can Buy*. This fact earned Sutton the ire of the academic community and their internationalist corporate backers, and he soon found himself out of his academic fellowship and all but completely black-listed from the America's "open-minded" and "brilliant" academic institutions.

Undaunted, Sutton continued to document the work and goals of this corporate elite in a two-volume study *Trilaterals Over Washington*, and a ground-breaking work on the notorious Skull and Bones Society at Yale University, *America's Secret Establishment*. But it is for his trilogy culminating in *Wall Street and the Rise of Hitler* that Sutton is best known, for it is perhaps the best one-volume introduction to the shenanigans of American corporations and their German counterparts in the rise of Nazism and Adolf Hitler.

1. Putting it into Perspective: The Presumptive Goals of the International Elite in Funding Communism and Nazism

But why would the same corporate elite wish to fund both Communism *and* Nazism, and to put them into power in two of the world's great military powers to begin with? There are two answers to this question, one long-term, and one more mid- to short-term. As the titles of Sutton's own *Wall Street and the Rise Of...*trilogy suggests, by placing into power Franklin Delano Roosevelt, Adolf Hitler, and Vladimir Lenin, the international elite was running a grand long-term experiment, not only in bringing socialism of one form or another into authority in the major powers of the world, but also to determine which version of socialism was the most robust in opposing a presumed threat, but also to determine the most pliable and easily manipulated by corporate elites. The long term goal was, of course, world corporate socialism.

The more short term reasons for this manipulation of three kinds of socialism – FDR’s “New Deal” socialism, Communist Socialism, and National Socialism – is more complex, and must be viewed from the chronological standpoint. Having put Bolshevism into power, the internationalist corporate elite soon found itself faced with a problem, namely, that the Soviet Union and its Communist International was *serious* about expanding communist power – under Soviet auspices – around the world, and particularly into central Europe and Germany. Faced with the possibility of a power bloc centered on Russia and Germany under Communist control, the ability to manipulate and control that bloc – much less oppose it if the need arose – became quite problematical, if not downright impossible. In short, the balance of power, upon which the larger scheme depended, would have been threatened.

Having created the Communist monster, the elite then decided to finance another monster – Nazism – to oppose it. This plan was indeed realistic, since Germany was the only power conceivably in a position to oppose Russia economically and militarily.³ France and Great Britain simply had neither the muscle nor the geopolitical position to do it, and the United States was ill-disposed to become involved in European affairs. As a result of these considerations, the pattern of international corporate cartel and licensing arrangements between the Western Powers – particularly the United States – and Germany emerged.

2. A Case in Point: Hitler’s Reichsbank President: Dr. Hjalmar Horace Greeley Schacht

An example of this American-German corporate cooperation is easily seen in Hitler’s first Reichsbank President, Dr. Hjalmar Horace Greeley Schacht. As Sutton observes, the pattern of incestuous relationships between the German and American corporate elites is exemplified in Schacht, for Schacht’s father, prior to moving his family to America,

Worked at the Berlin office of the Equitable Trust Company of New York in the early twentieth century. Hjalmar was born in

Germany rather than New York only by the accident of his mother's illness, which required the family to return to Germany...To record his American origins, Hjalmar's middle names were designated "Horace Greeley" after the well-known Democrat politician. Consequently, Hjalmar spoke fluent English and the post-war interrogation of Schacht in project Dustbin was conducted in both German and English. The point to be made is that the Schacht family had its origins in New York, worked for the prominent Wall Street financial house of Equitable Trust (which was controlled by the Morgan firm), and throughout his life Hjalmar retained these Wall Street connections. Newspapers and contemporary sources record (his) repeated visits with Owen Young of General Electric; Farish, chairman of Standard Oil of New Jersey; and their banking counterparts. In brief, Schacht was a member of the international financial elite... He is a key link between the Wall Street elite and Hitler's inner circle.⁴

Remember that connection to the Morgan financial interests, since it will resurface in a strange way once we examine the postwar financial plans of the Nazi International.

3. International Cartel and Licensing Agreements Between I.G. Farben and American Corporations

According to Sutton, "The contribution made by American capitalism to German war preparations before 1940 can only be described as phenomenal."⁵ Just how phenomenal? Consider only the fact that

In 1935 Germany produced domestically only 300,000 tons of natural petroleum products and less than 800,000 tons of synthetic gasoline; the balance was imported. Yet, ten years later in World War II, after transfer of the Standard Oil of New Jersey hydrogenation patents and technology to I.G. Farben (used to produce synthetic gasoline from coal), Germany produced about 6 ½ million tons of oil – of which 85 percent (5 ½ million tons) was synthetic oil using the Standard Oil

hydrogenation process. Moreover, the control of synthetic oil output in Germany was held by the I.G. Farben subsidiary, Barunkohle-Benzin A.G., and this Farben cartel itself was created in 1926 with Wall Street financial assistance.⁶

What did America get in return for Farben's license to produce synthetic gasoline under Standard Oil's patent? More about that in a moment.

a. The Dawes and Young Plans

In order to appreciate the German cartel system and its unique power in world finance capitalism at the time, however, it is necessary to go back to the end of World War One, the Versailles Treaty, and the enormous war reparations it imposed on Germany.⁷ Since World War One had left the world's gold standard all but shattered in a tapestry of loans and credits, the outcome was predictable, particularly in Germany's case: the German government simply could not pay the reparations in any timely and meaningful fashion, and began deliberately to inflate its currency, paying the Allies back with increasingly worthless Reichsmarks, and ruining its own economy in the process as factories shut down and unemployment soared.

It was clear that something had to be done, and the only country at that time that could do it was the only creditor nation in the world with enough liquid capital worth anything to loan: the United States. It is in this context that the 1924 Dawes Plan and the 1928 Young Plan emerged as the latest scheme of international capitalists to milk Germany for all she was worth, for the ruin of the Reichsmark provided them with a golden opportunity "to float profitable loans" with valuable American dollars to the "German cartels in the United States."⁸ Both of these plans "were engineered by these central bankers, who manned the committees for their own pecuniary advantages, and although technically the committees were not appointed by the U.S. Government, the plans were in fact approved and sponsored by the Government."⁹

The essence of both plans was that the large U.S. central banks floated German bond issues which were paid for by American dollars. In turn, part of these funds were then used by Germany to repay the war reparations imposed by the Versailles Treaty. But as Sutton also notes, under these two plans

Germany paid out to the Allies about 86 billion marks in reparations. At the same time Germany borrowed abroad, mainly in the U.S., about 138 billion marks – thus making a net German payment of only three billion marks for reparations (sic). Consequently, the burden of German monetary reparations to the Allies was actually carried by foreign subscribers to German bonds issues by Wall Street financial houses – at significant profits for themselves, of course.¹⁰

As will be seen in a moment, much of these funds were actually used by the German corporations borrowing them to create the cartel system that dominated late Weimar Germany and that continued throughout the Nazi era.

It was the Young Plan, however, that began the process of waking German capitalists and industrialists up to the threat, for it was a clever, and insidious, adaptation of this bonds-for-loans scheme that constituted the Dawes Plan, for under the 1928 Young Plan – named after its sponsor Owen Young – the bonds were conceived as “a device to occupy Germany with American capital and *pledge German real assets for a gigantic mortgage held in the United States.*”¹¹ There was, of course, predictably a loophole granted to this scheme, for “German firms with U.S. affiliations evaded the Plan by the device of temporary foreign ownership.”¹² Thus, the *Allgemeine Elektrizitäts Gesellschaft*, or A.E.G., German General Electric, which was of course affiliated with General Electric in the United States, was “sold to a Franco-Belgian holding company and evaded the conditions of the Young Plan.”¹³ And lest it be forgotten – for it is an important part of the subsequent story in this book – the A.E.G. was also the German firm that built the power plant for the Nazi Bell device.¹⁴

If the financial “arrangements” of the Young Plan sound all too familiar, they ought to, for a similar phenomenon is happening with the corporate and public assets of the United States in recent years, as public infrastructure is mortgaged to private interests to manage the U.S.A.’s burgeoning national debt.

But America’s internationalist capitalist-socialist elite had not banked – pardoning the pun – on one thing, and it is a lesson they seem to have forgotten: not all German cartelists and industrialists were loathe to abandon patriotism or pride in their culture and nation. Indeed, German steel magnate Fritz Thyssen observed that he “turned to the National Socialist Party only after (he) became convinced that the fight against the Young Plan was unavoidable if complete collapse of Germany was to be prevented.”¹⁵ Clearly, if all real German assets were tied up in international agreements that were essentially mortgages, and these in turn were woven into an intricate pattern of mounting debt, then Germany’s days as a sovereign nation were numbered.

Thyssen’s comment also contains an implied warning about the activities of the postwar Nazi International, for if the international corporate elite was slow to appreciate the dangers of their activities in fomenting a resistance movement within its own ranks, and slow to appreciate the dangers of nationalist backlash in its ranks, the Nazis, as we shall see in subsequent chapters, were not only alive to the possibility, but also learned to exploit those internationalist leanings within the global financial world for themselves.

In any case, the American loans that were floated to German cartels under these Plans were enormous. A.E.G. received \$35,000,000 from National City Co., the enormous German steel cartel *Vereinigte Stahlwerke* (United Steelworks) received \$70,225,000 of underwritten securities from the Wall Street firm of Dillon, Read, and Co., and American I.G. Chemical, I.G. Farben’s American subsidiary, was the go-between for a loan of \$30,000,000 from National City Co.¹⁶

What this meant in terms of German business was that two of these three giant cartels – I.G. Farben and *Vereinigte Stahlwerke* – were able to control almost all business related to German war-making industrial potential by the mid-1920s. Sutton puts it this way:

After the mid-1920s the two major German combines of I.G. Farben and Verienigte Stahlwerke dominated the chemical and steel cartel system created by these loans. Although these firms had a voting majority in the cartels for only two or three basic products, they were able – through control of these basics – to enforce their will throughout the cartel. I.G. Farben was the main producer of basic chemicals used by other combines making chemicals, so its economic power position cannot be measured by its capacity to produce a few basic chemicals. Similarly, Verienigte Stahlwerke, with a pig-iron capacity greater than that of all other German iron and steel producers combined, was able to exercise far more influence in the semifinished iron and steel products cartel than its capacity for pig-iron production suggests. Even so the percentage output of these cartels for all products was significant:

Verienigte Stahlwerke Products	Percent of total German Production in 1938
Pig iron	50.8
Pipes and tubes	45.5
Heavy plate	36.0
Explosives	35.0
Coal tar	33.3
Bar steel	37.1
I.G. Farben	Percent of total German Production in 1938
Synthetic methanol	100.0
Magnesium	100.0
Chemical nitrogen	70.0
Explosives	60.0
Synthetic gasoline (high octane)	46.0 (1945)
Brown coal	20.0 ¹⁷

With some justification, then, it could be said that these two cartels represented the core of Nazi Germany’s military-industrial complex: “In brief, in synthetic gasoline and explosives (two of the very basic elements of modern warfare), the control of German World War II output was in the hands of two German combines created by Wall

Street loans under the Dawes Plan.”¹⁸ I.G. Farben in fact dates from 1925 when its chairman, Hermann Schmitz, created the giant cartel by merging “six already giant German chemical companies,” Badische Anilin, Bayer, Agfa, Hoechst, Weiler-ter-Meer, and Griesheim-Elektron.¹⁹ By 1928, Schmitz had organized its American holding companies – American Bayer, General Anilin Works, Agfa Ansco, and Winthrop Chemical – into a parent Swiss holding company, I.G. Chemie, and in 1929 all these firms were merged to become American I.G. Chemical Corporation, “later renamed General Aniline & Film.”²⁰

But this barely scratches the surface.

Between 1927, only two years after the founding of the cartel, and the outbreak of the war in 1939, I.G. Farben had more than doubled in size. The Wall Street financiers who made the loans to Hermann Schmitz to form this cartel had indeed created a monster, and that monster, in turn, was not proving to be as cooperative or pliable as they might have wished:

By 1939 I.G. acquired a participation and managerial influence in some 380 other German firms and over 500 foreign firms. The Farben empire owned its own coal mines, its own electric power plants, iron and steel units, banks, research units, and numerous commercial enterprises. *There were over 2,000 cartel agreements between I.G. and foreign firms – including Standard Oil of New Jersey, DuPont, Alcoa, Dow Chemical, and others in the United States. The full story of I.G. Farben and its world-wide activities before World War II can never be known, as key German records were destroyed in 1945 in anticipation of Allied victory.*²¹

Small wonder, then, that it took over fifty years to liquidate the company! Indeed, Sutton’s observation that key German corporate records were deliberately destroyed at the end of the war raises the key question of what in Farben’s tapestry of cartel agreements, corporate interlock, and influence in other corporations was so sensitive that it had to be hidden from the Allies?

In any case, these cartel arrangements were used by I.G. Farben to prepare Germany for war, both by acquiring technologies from abroad under licensing agreements, but also to deny Germany's enemies the ability to rely on similar technologies in their own war production. Case in point: under Farben's licensing agreements, the giant cartel obtained from Standard Oil of New Jersey America's process for making synthetic gasoline in return for a license to Standard Oil for Farben's synthetic rubber or "buna"-making technology.²² But the power of the corporation was such that, while it used Standard Oil's technology to make gasoline and oil for Hitler's tanks, bombers, and warships, it denied the Americans the ability to produce much-needed synthetic rubber, throughout and right up to the very end of the war! Additionally, Farben's global extent and penetration into foreign firms also provided it with a ready supply of very reliable intelligence on Germany's enemies' war production capabilities and production runs, affording Germany a very clear picture of her enemies' military intentions.

But the important point to notice here, and it is one that Sutton himself – not to mention Farben's elitist Wall Street backers - only hints at, is that I.G. Farben, while a "multinational global corporation" in every modern sense, was a corporation acting always around a solidly *German* core and in the German national interest. Sutton puts it this way, and in so doing, soft-pedals its enormous implications: "These arrangements were used by I.G. Farben to advance Nazi policy abroad, to collect strategic information, and to consolidate a world-wide chemical cartel."²³ It was a lesson the Nazi International would learn well.

So organized was Farben's intrinsic *rebellion* against the very American international financial interests that set it up, that it had its own espionage office, its Berlin N.W. 7 office. This unit "operated under Farben director Max Ilgner, nephew of I.G. Farben president Hermann Schmitz. Max Ilgner and Hermann Schmitz were on the board of American I.G., with fellow directors Henry Ford of Ford Motor Company, Paul Warburg of Bank of Manhattan,²⁴ and Charles F. Mitchell of the Federal Reserve Bank of New York."²⁵ Given Farben's behavior as a *German* multinational cartel, the presence of these prominent American executives on its American subsidiary's

board can only represent the presence of dupes; Farben was playing Wall Street for all it was worth. Indeed, Farben far exceeded Wall Street's desires simply to have Nazi Germany act as a counterbalance to Soviet Russia, for it "did more than just comply with orders from the Nazi regime. Farben was an initiator and operator for the Nazi plans for world conquest....In fact, the (German) Army only rarely had to approach Farben; it is estimated that about 40 to 50 percent of Farben projects for the Army were initiated by Farben itself."²⁶ Farben was not content to play the Wall Street role of geopolitical counterbalance, and when Nazi Germany had overrun most of Europe by May of 1941, it was clear even to the Wall Street blockheads that had put both into power, that both monsters – Nazi Germany and I.G. Farben – had to be put down. But putting it down was not going to be easy, for consider all that has been stated thus far in terms of what power I.G. Farben actually wielded: it had penetrated the Federal Reserve Bank of New York (Charles Mitchell and Paul Warburg), penetrated Ford Motor Company (Henry and later Edsel Ford), penetrated the Bank of Manhattan (Paul Warburg), and Standard Oil of New Jersey, just to mention a few.²⁷

There is also another fact worth mentioning, as it will play a prominent role much later in this book when we examine the postwar scientific activities of the Nazi International, and that is the presence of "one of the more prominent Farben intelligence workers in N.W. 7," the Netherlands' Prince Bernhard, the founder of the famous Bilderberger group.²⁸

4. I.T.&T. and Nazi Germany

Another American multinational corporate giant that will figure prominently in later sections of this book was International Telephone and Telegraph, founded in 1920 by Sosthenes Behn.²⁹ Behn, with Morgan backing, purchased Spain's telephone monopoly, Compania Telefonica de Espana, in 1923, and thus began the I.T.& T. empire.³⁰ While there is no evidence that I.T.&T. supported the rise of Hitler prior to the war to the extent that other Wall Street firms did, I.T.& T. certainly supported him *during* the war, since it made payments to none other than Heinrich Himmler via various I.T.& T. German

subsidiaries.³¹ More importantly, through its purchase of a large interest in the German Focke-Wulf aircraft company, I.T.& T. was making profits from the German Focke-Wulf 190 fighter, Germany's most numerous and successful fighter, the better of the British Spitfire and the near equal of the American P-51 Mustang!³²

B. A Brief Note About Prescott Bush, Union Banking Corporation, and Fritz Thyssen

With the prominence of the Bush family in American politics and scandals, from the recent Savings and Loan scandal to the JFK assassination itself, where a G. Bush is mentioned in connection with trying to warn about the assassination, to the possible involvement of G.H.W. Bush in the "October Surprise" affair, his role as an ambassador to Red China and helping broker the Nixon-Mao agreement that would ship American factories, jobs, and technology to that country, his role as a former director of the CIA, and his family's business ties to the Bin Laden family of Saudi Arabia, and of course to his and his sons' questionable legacies as Presidents of the United States and also as members of the famous Skull and Bones secret society at Yale University, it should come as no surprise that his family also has a connection to the rise of Nazism under Adolf Hitler.

While most are probably familiar with this story, it is worth rehearsing its bare outlines again here, as an indicator of just how pervasive, extensive, and high-up the connections between Nazism and the American elite really are. In fact it is a story that will not go away, as a multi-billion dollar lawsuit has been brought against the Bush family by two survivors of the Holocaust.³³

While there is no suggestion that Prescott Bush³⁴ was sympathetic to the Nazi cause, the documents reveal that the firm he worked for, Brown Brothers Harriman, acted as a US base for the German industrialist, Fritz Thyssen, who helped finance Hitler in the 1930s before falling out with him at the end of the decade. The Guardian has seen evidence that shows Bush was the director of the New York-based Union Banking

Corporation that represented Thyssen's US Interests and he continued to work for the bank after America entered the war.³⁵

The *Guardian's* commentary is more balanced than the usual conspiracy mongering or Bush-bashing that one finds on the internet or in several books, for it points out the fact that Prescott Bush's connection to Thyssen was indirect, and also points out that Thyssen himself became quite disenchanted with the Nazis once they were in power, even to the extent of serving time in a concentration camp.

That said, however, there was enough evidence in recently declassified U.S. National Archives documents to prompt "one former US war crimes prosecutor to argue that the late senator (Prescott Bush's) action should have been grounds for prosecution for giving aid and comfort to the enemy."³⁶ Whatever the legalities of the hypothetical case may be – and there are many as will be seen shortly – the documents themselves tell an interesting story. There are three basic sets, the first dealing with the Harriman company, and Prescott Bush's role as a director and shareholder in several Thyssen-controlled firms.³⁷ The second set of documents relates to the seizure of company assets in America that were fronts for German firms: The Union Banking Corporation, the Holland-American Trading Corporation, the Seamless Steel Equipment Corporation, and the Silesian-American Company, all of which were ventures tied to Prescott Bush.³⁸ The third set of documents relates specifically to I.G. Farben and its ties to Thyssen's Silesian steel and mining operations.

The fact that Prescott Bush may or may not have been involved with people who helped the Nazis into power is from one standpoint immaterial, for one can hardly blame either Presidents Bush for the actions of their father or grandfather. Similarly, the fact that Thyssen himself grew disgusted with the Nazis hardly makes the case for Prescott Bush being a Nazi sympathizer any stronger either. Finally, the fact that Bush's company's assets were only seized a mere six months after America's entry into the war does not say much either, since in that short time period American corporations were – at least in theory – supposed to be disentangling themselves from any trade with the enemy (unless one was Standard Oil or I.T.&T., of course).

Prescott Bush's business dealings with the Nazis hardly have the odor about them that those other Wall Street firms and personalities, already mentioned at some length in this chapter, do.

It is only when viewed in a much wider context of the Bush family's contacts and business dealings – a task far beyond the scope of this book – that Prescott Bush's activities with Thyssen might be seen as part of a larger pattern.

And then there is that matter of the Bush family's purchase of a ranch, not in the U.S.A., Canada, Australia, or the usual contenders, but in Paraguay. Perhaps they like the scenery. Or perhaps they want to be near old family friends...

C. Conclusions

If there is a lesson to be learned from I.G. Farben's "story," then it is one all - whether corporate financiers or ordinary men – should learn, and that is that the best laid plans of international bankers with a global agenda not only can backfire, they can backfire in the major ways called Nazi Germany, I.G. Farben, and World War Two.

But there was another lesson to be learned from I.G. Farben's success story as the world's first real major military-industrial complex, for its pattern of internationalization of the Nazi ideology around a solidly German core would be well-learned by the man who had the most high-level day-to-day contact with it: Nazi Party *Reichsleiter* Martin Bormann. Just how closely he followed the Farben model of internationalizing the ethnic character of postwar Nazism around a solid German core, and using Farben's pattern of cartel arrangements, corporate interlock and penetration, and blackmail, and the well-placed assassination or two, remains to be seen...

¹ Jim Marrs, *The Rise of the Fourth Reich: The Secret Societies that Threaten to Take Over America* (William Morrow, 2008), p. 118.

² Anthony Sutton, *Wall Street and the Rise of Hitler*, reformed-theology.org/html/books/wall_street/introduction.htm, p. 1.

³ In my experience, most Americans are so ill-informed about history that they do not realize that Russia surrendered to Germany in March, 1918. While the Menshevik socialist government of Russia

wished to continue the war with imperial Germany, militarily this was all but a foregone conclusion, as the Russian armies were hopelessly outclassed and outgunned. The Eastern Front of World War One had become a slaughter-house for the Russians. Under the terms of the Russian surrender negotiated with the new Bolshevik government, Germany would occupy vast tracts of Byelo-Russia and the Ukraine, as well as what would later become the Baltic States of Lithuania, Latvia, and Estonia. The Russian surrender made possible the transfer of large amounts of troops to the Western Front for the large German offensive in March of 1918 that nearly broke the back of French and British resistance. The offensive was led by General Erich Ludendorff, a subsequent earlier supporter of the Nazi Party.

⁴ Anthony Sutton, *Wall Street and the Rise of Hitler*, reformed-theology.org/html/books/wall_street/introduction.htm, p. 4,

⁵ Anthony Sutton, *Wall Street and the Rise of Hitler*, reformed-theology.org/html/books/wall_street/chapter_01.htm, p. 1.

⁶ Ibid.

⁷ These reparations were largely insisted upon by France, which bore the economic brunt, infrastructure damage, and dislocation of the war. In doing so, however, France was not acting uniquely nor without precedent, since the German Empire had imposed similar reparations on France at the end of the Franco-Prussian War in 1871. The French Third Republic repaid these reparations.

⁸ Anthony Sutton, *Wall Street and the Rise of Hitler*, reformed-theology.org/html/books/wall_street/chapter_01.htm, p. 2.

⁹ Ibid.

¹⁰ Ibid., p. 3.

¹¹ Anthony Sutton, *Wall Street and the Rise of Hitler*, reformed-theology.org/html/books/wall_street/chapter_01.htm, p. 4, emphasis added.

¹² Ibid.

¹³ Ibid.

¹⁴ See my *SS Brotherhood of the Bell*, pp. 155-156.

¹⁵ Anthony Sutton, *Wall Street and the Rise of Hitler*, reformed-theology.org/html/books/wall_street/chapter_01.htm, p. 4.

¹⁶ Ibid., p. 6.

¹⁷ Anthony Sutton, *Wall Street and the Rise of Hitler*, reformed-theology.org/html/books/wall_street/chapter_01.htm, pp. 7-8.

¹⁸ Ibid., p. 8.

¹⁹ Anthony Sutton, *Wall Street and the Rise of Hitler*, reformed-theology.org/html/books/wall_street/chapter_02.htm, p. 1.

²⁰ Ibid.

²¹ Ibid., p. 2, emphasis added.

²² Anthony Sutton, *Wall Street and the Rise of Hitler*, reformed-theology.org/html/books/wall_street/chapter_01.htm, p. 5

²³ Ibid., p. 4.

²⁴ And also, let it be noted, a former director of the New York Federal Reserve Bank.

²⁵ Anthony Sutton, *Wall Street and the Rise of Hitler*, reformed-theology.org/html/books/wall_street/chapter_01.htm, p. 4.

²⁶ Ibid., p. 7

²⁷ Ibid., p. 12

²⁸ Sutton, *Wall Street and the Rise of Hitler*, reformed-theology.org/html/books/wall_street/chapter_02.htm, p. 4.

²⁹ Ibid., reformed-theology.org/html/books/wall_street/chapter_05.htm, p. 1.

³⁰ Ibid.

³¹ Ibid.

³² Ibid. Of course, American firms were not the only ones willing to make a profit from both sides in the war. The famous German munitions maker, Krupp, bought a large interest in the Swedish Bofors armaments works, which produced the double and quadruple barreled 40mm anti-aircraft guns produced under license in America and in effective use on almost all American ships, shooting down the planes of its Japanese ally!

³³ Ben Aris and Duncan Campbell, "How Bush's Grandfather Helped Hitler's Rise to Power," *The Guardian*, Saturday, September 25, 2004, www.guardian.co.uk/world/2004/sep25/usa.secondworldwar, p. 1.

³⁴ Father to President George Herbert Walker Bush and grandfather to President George Walker Bush.

³⁵ Ben Aris and Duncan Campbell, "How Bush's Grandfather Helped Hitler's Rise to Power," *The Guardian*, Saturday, September 25, 2004, www.guardian.co.uk/world/2004/sep25/usa.secondworldwar, p. 1.

³⁶ Ben Aris and Duncan Campbell, "How Bush's Grandfather Helped Hitler's Rise to Power," *The Guardian*, Saturday, September 25, 2004, www.guardian.co.uk/world/2004/sep25/usa.secondworldwar, p. 1.

³⁷ *Ibid.*, p. 2.

³⁸ *Ibid.*

✠ 3 ✠

**“Raindrops Keep
Falling on my Head:”
Operations Regentröpfchen, Adlerflug,
and Bormann’s Strategic
Evacuation Plan**

*“These concerns have been deliberately welded together by
exchanges of
stock to the point where a handful of men can make policy and
other
decisions that affect us all.”*

Orvis A. Schmidt, U.S. Department of the Treasury,
Commenting on the Bormann’s Strategic Evacuation Plan¹

Between February and August of 1943 the military fate of Adolf Hitler’s Thousand Year Third Reich was sealed in a series of military operations that almost boggle the imagination. After the surrender of the encircled German Sixth Army at Stalingrad on February 2nd, STAVKA, the Soviet High Command, gambled everything in a massive counteroffensive designed no less than to drive four massive columns westward, and then sweep south to the Black Sea, cutting off and encircling the entire German Army Group South. Four Soviet armies and massive armored formations were committed to the effort.

Unfortunately for the Soviets, Hitler had entrusted the command of Army Group South to Field Marshal Erich Von Manstein, the man whose unorthodox plan had led to the quick Nazi victory over France

in 1940, and whose Eleventh Army had pulverized the Russian fortress of Sevastopol on the Black Sea in 1942.² As the lead Soviet reconnaissance columns were within only five miles of Von Manstein's Army Group Headquarters at Zaporozhe on the bend of the Dnieper River, one of Von Manstein's staff officers heard the Field Marshal mutter under his breath as he watched the relentless advance of red arrows on the situation map, "And the best of luck to you." A month later, Von Manstein's carefully orchestrated withdrawal and counter-offensive had eliminated all four Soviet armies and sent the Red Army reeling back to essentially the same lines as those from which the Germans had started their 1942 offensive.³

There was one problem: an enormous bulge or salient stretched into German lines centered around Kursk, with the Germans occupying Orel to the north and Belgorad to the south. The Russians quickly began to fortify the salient, committing the bulk of their artillery and armored reserves to the area, and the Germans responded in kind, building up a massive pool of armor, artillery, and aircraft for an offensive to encircle the Russians. Hitler opened his offensive on July 5, 1943. When it was all over, the Germans had lost almost 50,000 men, 300 tanks, and 200 aircraft. The Soviets fared much worse, losing almost ten times as many men, three times as many tanks, and an unknown amount of aircraft in the largest land, tank and air battle in history.⁴

However, numbers do not tell the whole story, for the Germans, the offensive broke the back of the Wehrmacht's offensive capability for good; for the Soviets, massive though their losses were, were able to shift to the offensive, never to let up until their tanks rolled into Berlin in 1945. The mood in Berlin as these events from Stalingrad to Kursk unfolded was indeed somber, and one who watched them all with a cool eye to the future was Adolf Hitler's personal secretary and chosen leader of the Nazi Party, *Reichsleiter* Martin Bormann.

A. The Beginnings of Evacuation: Operation Fireland

Bormann was nothing if not a cynical realist.

With the military disaster of Stalingrad, Bormann and other top Nazi leaders began the quiet though “disorganized” flight of capital from Nazi Germany to safe havens abroad, an operation codenamed *Aktion Feuerland*, Operation Fireland.

The treasure consisted of hundreds of millions of reichsmarks; boxes and boxes of gold and platinum, pearls and diamonds; crates full of the priceless art of Europe; and billionaire bundles of stocks and other securities. The loot was amassed in a series of bank safes and underground vaults throughout the Reich – until Martin Bormann was made aware of its existence by one of his many internal intelligence conduits. In late 1943, he took control of much, though not all, of this booty and informed Hitler of its existence and a plan he had formulated for its conservation.

“Bury your treasure, for you will need it to begin a Fourth Reich,” Hitler had responded. With this blessing, Bormann took control of as many as six U-boats, some of them unmarked, from Gross Admiral Karl Doenitz, and garnered the support of Generalissimo Francisco Franco to headquarter the U-boats in the Spanish port cities of Cadiz and Vigo. The U-boats for the next two years, supplied by cargo planes from Germany that transported the treasures to the coastal towns on the Atlantic, began a non-stop circuit transporting the treasure to the far southern reaches of Argentina – the region known as Tierra del Fuego, or Land of Fire. At their destinations they were unloaded by Bormann’s mysterious minions and deposited into a variety of international bank accounts controlled by a cryptic cabal of Bormann partners. This was *Operation Fireland*.⁵

With *Aktion Feuerland* one sees the outlines of the postwar Nazi evacuation taking shape, and in this respect, the following things should be noted:

- 1) An escape route through Franco’s Nationalist Spain;
- 2) Reliance upon unmarked or “black” U-boats for the shipment (shades of Wilhelm Landig once again!);

- 3) Deposit of Nazi treasures into “international bank accounts;” and,
- 4) Implied Argentine complicity at the other end of the escape route.

Each of these four points will, of course, be explored in this book.

B. Operation Bernhard

Bormann was nothing if not criminally ingenious. In 1942, for example, he sponsored the top secret Project Bernhard, an effort by Nazi Germany to counterfeit British pound notes and circulate them. The plan was double-edged, designed both to cripple the British war economy and to provide much-needed hard cash for Nazi Germany’s own war efforts. Researcher Carter Hydrick has established that at its height, the project was printing 400,000 British notes per month, and that on its conclusion, some \$600,000,000 worth of counterfeit British pounds had been circulated.⁶ Bormann would deposit these funds in foreign banks through his business contacts, and then exchange the funds for other hard currencies, usually dollars. Rather than divert all these funds back into the Nazi war economy, however, Bormann would skim his own cut and squirrel it away for his own use at a future date. Hydrick notes that “of the \$600 million of counterfeit currency processed, approximately \$300 million has never been accounted for, presumably lost to Bormann’s enigmatic interchange.”⁷

C. The Hotel Maison Rouge Meeting: Operations Regentröpfchen and Adlerflug

It was after the successful Allied invasion of the beaches of Normandy, France, however, that the long-range postwar Nazi corporate planning began in earnest. To understand Bormann and his postwar plans, it is necessary to understand his rise to power and methods of operation.

1. The Growth of Bormann’s Power and International Network

Long time CBS journalist Paul Manning, an associate of that network's most famous newsman, Ed Morrow, summarized Martin Bormann's personality and ability in the following words:

Bormann was a classic embodiment of the dictator in the antechamber, a type now usual in governments around the world and in the multinational corporations, which usually tell governments what to do. Those who scorned him were typical stalwarts of every revolutionary movement, the old guard of faithful fighters, the populists, who assume their early success will endure unchangingly. Great individuals build up great corporations; but it is the second generation of professional managers to whom shareholders look to carry on the tradition of expansion and profits. Martin Bormann was a second generation professional who consolidated for Hitler the power he had accumulated. He was at ease in the bureaucratic apparatus and mastered the mechanisms of government with the greatest skill.⁸

Bormann, in short, was a *professional* Nazi, aiming to *maintain* the Party, its power, and agenda and to give its institutions and goals permanence.

Once Adolf Hitler had appointed Bormann to be Rudolf Hess's chief of staff and also Nazi Party treasurer, the rest, for the financially brilliant Bormann, was history. Even before he replaced Hess as Party *Reichsleiter* after the latter's ill-fated flight to Britain, Bormann was the de facto mover and governor of the Party machinery and finances. Quickly gaining power of attorney over Hitler's personal finances, he arranged for every picture of Hitler on a postage stamp throughout the Reich to pay the Führer a personal royalty for the use of his image, a maneuver that soon made Hitler a very wealthy man in his own right. As party treasurer, Bormann soon controlled the housekeeping budgets for "Hitler himself and his girlfriend Eva Braun, as well as for Goering, Goebbels, and Himmler."⁹ By 1938, in fact, Bormann was in control of all of Hitler's financial business,

leaving the Führer to the more important tasks of running the country.

After Rudolf Hess's flight to England in May, 1941, Bormann's career as a professional Nazi stepped into high gear. Bormann was named by Hitler to replace Hess as Party *Reichsleiter* and Party Chancellor.

The wording was brief and low key, but it marked a giant leap forward for Martin Bormann. Henceforth, the entire party ministry would be under him. Every Nazi within Germany, in occupied Europe, and overseas was answerable directly to him. Within the year Hitler added to Bormann's titles those of Secretary to the Fuehrer and Lieutenant General of the SS.¹⁰

As Party *Reichsleiter*, Bormann headed the Nazi Party's *Auslands* —*Organization*, the overseas party offices and network established prior to the Nazi assumption of power to keep Germans abroad abreast of developments in the Party, and of course, to keep a watchful eye on their activities and that of their host countries. In short, the Nazi Party leadership gave Bormann access not only to all of Nazi Germany's political, military, and financial wheeler-dealers, it also gave him control over its own independent Party international espionage and fifth column network.¹¹ Most importantly, all German businesses abroad were required, once the Nazis took power, to have their own Nazi Party *Auslands-Organization* liaison men, a fact that will assume some importance when we examine Bormann's strategic evacuation plans and postwar agendas for the Nazi International. In particular, all employees of the big three German banks, Deutschebank, Dresdnerbank, and Commerzbank, were required to be party members.¹² In this way Bormann had up to the minute and excellent intelligence on the international machinations of the global corporate elites.

As Manning astutely observes, Bormann

Inherited this vast intelligence and fifth-column system upon assuming leadership of the party. He tightened it up and instilled it with a new purpose; it became an instrument used to

implement his flight capital program in the last few months of the war.¹³

2. Bormann and I. G. Farben

But it was Bormann's friendship with I.G. Farben directors Hermann Schmitz, Max Ilgner, and others that gave him access to Farben's far more extensive industrial espionage network, and that additionally provided him with the corporate networks needed to make his flight capital plan work. Manning points out that one city, in particular, was a veritable beehive of banking activity on behalf of I.G. Farben, *Verieinigte Stahlwerke*, A.E.G., Merck, Siemens, and other big German cartels: Buenos Aires.¹⁴ With the financial and corporate knowledge Farben placed at his disposal, with the control of the Nazi Party's own considerable finances and plunder, with his own Party network of agents and "enforcers" in place, Bormann "now had a vast overseas financial and commercial network to do his bidding."¹⁵ It only remains to see what his bidding was.

3. The Hotel Maison Rouge Meeting and Their Grand Design

On August 10, 1944 an SS staff car flying the Nazi swastika and SS flags from its bumpers pulled up in front of the Hotel Maison Rouge located on the Rue des France-Bourgeois in Strasbourg, nestled along the French banks of the Rhine river separating Alsace from Baden-Württemberg. It carried one SS Obergruppenführer Scheid, who doubled as Dr Scheid, "director of the industrial firm of Hermadorff & Schenburg Company."¹⁶ Dr. Scheid had been ordered to chair a top secret conference of German industrialists at the picturesque Alsatian city by none other than *Reichsleiter* Martin Bormann himself.¹⁷ As Bormann confided to Scheid, who in turn passed the remarks on to the conference attendees, "The steps to be taken as a result of this meeting will determine the postwar future of Germany."¹⁸ Bormann and Scheid were perhaps a bit disingenuous, as will be seen momentarily, for the steps they undertook to put into place at the conference concerned more than

just Germany, but indeed the whole postwar political and economic future of Europe, and for that matter, of the Nazi Party itself, and its goals and policies. The flight capital plans were variously known as *Aktion Regentröpfchen* and *Aktion Adlerflug*, Operations Raindrop and Eagle Flight, respectively.

Every precaution had been taken by the SS to ensure the meeting's complete secrecy.

Waffen SS technicians had swept the entire room, inspecting for hidden microphones and miniature transmitters. As an additional precaution, all suites flanking the conference suite had been held unfilled, as had the floors above and below, out of bounds for the day. Lunch was to be served in the conference suite by trusted Waffen SS stewards. Those present, all thirteen of them, could be assured that the thorough precautions would safeguard them all, even the secretary who was to take the minutes, later to be typed with a copy sent by SS courier to Bormann.¹⁹

The precautions were entirely justified, given who was in attendance and what was being discussed.

The roster of attendees looks like a roll call of some of Germany's top industrial firms:

Present were Dr. Kaspar representing Krupp, Dr. Tolle representing Röchling, Dr. Sinceren representing Messerschmitt, Drs. Kopp, Vier, and Beerwanger representing Bussing, Drs. Ellenmayer, Yanchew, and Koppshiem representing various factories in Posen, Poland (Drose, Yanchew, & Co., Brown-Boveri, Herkuleswerke, Buschwerke, and Stadtwerke); Dr. Meyer, an official of the German Naval Ministry in Paris; and Dr. Strossner of the Ministry of Armament, Paris.²⁰

Scheid began the conference by informing the attendees that the battle of France was lost, and that all industrial plants as could be

evacuated to Germany were to be so.



*The Hotel Maison Rouge as it is Still Seen to this day in
Strasbourg, Alsace, France*

After some perfunctory and obligatory remarks about the necessity of defending the West Wall and the Reich itself, Scheid settled down to business:

From now on,

he told the attendees,

*German industry must take steps in preparation for a postwar commercial campaign, with each industrial firm making new contacts and alliances with foreign firms. This must be done individually and without attracting suspicion. However, the party and the Third Reich will stand behind every firm with permissive and financial support.*²¹

To put it differently, there was to be no detailed coordination of these efforts by the Party itself, since that would attract Allied suspicion and ruin the whole venture. As Scheid made clear by his comments, each firm was to utilize existing contacts and to develop

new ones. But there was a catch: by pledging Party *financial* support – and we already have some inkling how substantial and large this could be – Bormann was signaling to his corporate representatives that he was, in effect, buying shares in their enterprises, and wanted intelligence from them, in return for that support. To drive this point home, Scheid informed the attendees that Bormann had suspended the 1933 law known as the Treason Against the Nation act, which “mandated the death penalty for violation of foreign exchange regulations or concealing of foreign currency.”²² The implied threat was simply that Bormann, through his network of intelligence contacts and agents, could easily “remove” any corporate executive or director that he wished if these implied directives were not complied with. It is a tactic that, as will be seen later in this work, proved very effective.

After delivering this implied threat, Scheid continued:

“The ground must now be laid on the financial level for borrowing considerable sums from foreign countries after the war.”

In other words, the war was lost, and German firms had to plan for the rebuilding of Germany, all with the tacit approval of Bormann and the Party.

As an example of the kind of support that had been most useful to Germany in the past, Dr. Scheid cited the fact that “patents for stainless steel belonged to the Chemical Foundation, Inc., New York, and the Krupp Company of Germany, jointly, and that of the United States Steel Corporation, Carnegie, Illinois, American Steel & Wire, National Tube, etc., were thereby under an obligation to work with the Krupp concern.” He also cited the Zeiss Company, the Leica Company, and the Hamburg-Amerika Line as typical firms that had been especially effective in protecting German interests abroad.²³

Note carefully what Scheid has disclosed about the *method* the Party was “encouraging” German corporations to use: they were to use existing license, patent, and cartel arrangements to leverage borrowing power and influence abroad; shades of I.G. Farben. And to the assembled corporate representatives, the lesson could hardly have been lost on them.

It was to be an expansion, on a far grander scale, of the prewar machinations of the Dawes and Young Plans that led to the creation of I.G. Farben in the first place. Negotiate, penetrate, infiltrate, and cartelize all transfers of technology, with German and Party interests solidly at the core; these were the watchwords of Bormann’s emerging Nazi International.

Scheid then adjourned the morning session of the meeting. On his signal, the attendees were served “a real Strasbourg lunch.” On a long side table SS valets placed trays “of *pâté de foie gras, matelote*, noodles, sauerkraut, knuckles of ham, sausages, and onion tarts, along with bottles of Coq au Riesling from nearby wineries. Brandy and cigars were also set out...”²⁴ After this feast, Dr. Scheid departed back to Germany to spread the word – quietly – to all concerned firms of the results and expectations of the conference, while a smaller conference reconvened in the afternoon under the chairmanship of Dr. Bosse of the Armaments Ministry.

This afternoon session is even more revealing of Bormann’s thoughts, intentions, and grand design. In attendance at this afternoon session were only three corporate representatives for Krupp, Hecko, and Röchling.²⁵ Dr. Bosse then made some interesting remarks, beginning by restating

*Bormann’s belief that the war was all but lost, but that it would be continued by Germany until certain goals to insure the economic resurgence of Germany after the war had been achieved. He added that German industrialists must be prepared to finance the continuation of the Nazi Party, which would be forced to go underground...*²⁶

While all this is revealing enough, what follows is truly extraordinary and breathtaking once its implications are carefully

considered. Bosse continued by outlining the way in which the Nazi Party and German corporations would liaise, and what their goals were to be:

“From now on, the government in Berlin,”

(meaning Bormann, of course)

“will allocate large sums to industrialists so that each can establish a secure postwar foundation in foreign countries. *Existing financial reserves in foreign countries must be placed at the disposal of the party in order that a strong German empire can be created after defeat. It is almost immediately required,*” he continued, *“that the large factories in Germany establish small technical offices or research bureaus which will be absolutely independent and have no connection with the factory. These bureaus will receive plans and drawings of new weapons, as well as documents which they will need to continue their research.* These special offices are to be established in large cities where security is better, *although some might be formed in small villages near sources of hydroelectric power, where these party members can pretend to be studying the development of water resources for the benefit of any Allied investigators.*”

Dr. Bosse stressed that knowledge of these technical bureaus would be held only by a very few persons in each industry and by chiefs of the Nazi Party. *Each office would have a liaison agent representing the party and its leader, Reichsleiter Bormann.* “As soon as the party becomes strong enough to reestablish its control over Germany, the industrialists will be paid for their effort and cooperation by concessions and orders.”

But there was even more!

At both morning and afternoon conferences, it was emphasized that the existing prohibition against the export of capital “is now completely withdrawn and replaced by a new Nazi policy, in which industrials with government assistance (Bormann to be the guiding leader) *will export as much of their*

capital as possible, capital meaning money, bonds, patents, scientists, and administrators.”

Bosse urged the industrialists to proceed immediately to get their capital outside Germany. *“The freedom thus given to German industrialists further cements their relations with the party by giving them a measure of protection in future efforts at home and overseas.”*

From this day, German industrial firms of all rank were to begin placing their funds – and, wherever possible, key manpower – abroad, especially in neutral countries....

Dr. Bosse closed the meeting, observing that “after the defeat of Germany, *the Nazi Party* recognizes that certain of its best known leaders will be condemned as war criminals. However, in cooperation with the industrialists, it *is arranging to place its less conspicuous but most important members with various German factories as technical experts or members of its research and designing offices.*”²⁷

All this requires some very careful unpacking, for obviously, Dr. Bosse is “speaking Nazi with the Bormann dialect.”

The following points may be gleaned from this lengthy passage:

- 1) Bormann basically confiscated any foreign reserves in the possession of German corporations and placed them under the control of the Nazi Party;
- 2) These funds in turn would be disbursed to corporations in aid of their fulfillment of the goals of the conference;
- 3) One primary goal was to establish “research bureaus” whose purpose, following the I.G. Farben N.W. 7 model, was to gather intelligence and steal foreign research as well as to conduct their own research;
- 4) Since these technical offices were to have their own Nazi Party liaison officer reporting directly to Bormann, it is clear that Bormann *intended* for his Nazi International to conduct not only espionage but *research* in its own right, under departments – the “technical offices” - of German corporations only very loosely connected to them;

- 5) Each such research bureau was to be established under a cloak of other activity, such as “investigating water resources;”
- 6) The capital flight program was designed to see to it that Allied authorities did *not* get the most valuable German scientists, technicians, or knowledge, as represented in patents, all of which were to be transferred overseas to safe havens, thus indicating that Bormann, in the light of all the previously enumerated considerations, intended for the Party to continue *an independent line of scientific research under its own control*, all the while managing and sharing any information gained through its espionage activities with the involved German corporations, as the Party and Bormann saw fit.

And all this implies something else, something very obvious, and very significant:

- 7) Martin Bormann *fully intended to survive the war in order to coordinate all these activities.*

Also, note again the implied threat in Bosse’s remarks that “The freedom thus given to German industrialists *further cements* their relations with the party *by giving them a measure of protection in future efforts at home and overseas.*”²⁸ Bormann, in other words, is playing the old organized crime game: offering “protection,” implying also the threat to use force against those very industrialists if they do not comply, and placing his party organization’s considerable international reach at their disposal if they do.

With the Strasbourg Maison Rouge meeting concluded, Dr. Bosse then telephoned Martin Bormann in Berlin “over secure SS lines”²⁹ to inform him that all attendees, not surprisingly, had agreed to the terms and conditions of the conference. Bormann’s next move, however, is revealing for what it says about the nature and mechanisms he hoped to use to construct his underground Fourth Reich and Nazi International, for he then telephoned Georg Von Schnitzler, one of the members of the central committee of directors of I.G. Farben.³⁰ Von Schnitzler informed Bormann that the postwar dependency of the victorious Allied countries on I.G. Farben “would be so great that despite German defeat, *I.G., in one way or another,*

could regain its position of control of the European chemical business.”³¹ Thus, even as German troops fell back from France and the Low Countries before the Allied advance, German industrialists, at Bormann’s behest, were busily buying major blocks of stock in French, Belgium, Dutch, and Luxemburg firms.

And never one to ignore or forget a detail, Bormann saw to it that his own personal records were shipped to South America – thus indicating again his determination to survive the war – via Munich, thence to Spain, and from there on freighters and U-boats ferrying SS men and other important Nazi sympathizers and treasures to South America.³² These records would ensure that his network of Nazi party corporate liaisons, intelligence agents, and financial agents, would run smoothly.

4. Allied Efforts to Roll Up the Bormann Flight Capital Plan

Needless to say, no program of this magnitude could be kept hidden from Allied intelligence forever; it was just too large. And Bormann, of all people, would have known this. So what was he really attempting to do? The clearest picture of Bormann’s business strategy emerges from a careful though necessarily brief consideration of Allied efforts to roll up his business fronts.

As a result of the Strasbourg meeting, Bormann

in turn established 750 camouflaged corporations under the names of companies or individuals for which he held power of attorney, and therefore over which he had total control, as vehicles for managing the income of the Flight Capital Program. These businesses were scattered across countries throughout Europe, the Mid-east and Latin America. Holdings were even kept in bank accounts in the United States of America...³³

Bear those locations – Europe, the Middle East, and Latin America – in mind, for they will show up again before this book is concluded.

As a result of Bormann’s operations, the Nazi Party liaisons established with the corporate world at the Strasbourg Maison Rouge meeting were able to penetrate 11 nations’ economies,

including Germany's, and to significantly influence them in the postwar world.³⁴ By the time of the European war's end, Bormann's "Nazi International" had "already ratholed \$800 million plus 95 tons of gold."³⁵

Carter Hydrick was not unaware of Allied efforts to roll up this postwar Nazi International, and accordingly contacted a member of the intelligence community "with whom (he) had connections and whom (he) maws told had researched the subject matter of these Nazi business dealings." What Hydrick found was disturbing:

Without mentioning (Paul) Manning or (William) Stevenson³⁶ by name, he asserted that what they had written about Nazi involvement in post-war international business preparations was true and that United States government intelligence agencies – he mentioned the CIA and its predecessor the OSS by name – had conducted a full inquiry into the issue. He asserted that these agencies had identified all of the relevant business dealings, had broken up the German cartels and stripped the Nazi owners of their financial properties and placed those instruments in the hands of the United States Alien Property Custodian program. He "shared" this information with me in the spirit of proving that, while certain German businessmen and high-ranking Nazis – he mentioned Bormann specifically – tried to survive the war supported by Nazi funds invested by clandestine means, the United State had found and uprooted the deception. Therefore, he insisted there was no story and no need for me to research further.³⁷

Just how much the CIA could be trusted to investigate former Nazis and their postwar business dealings is a moot point, since it had, as is now well-known, concluded through Allen Dulles the notorious deal with German military intelligence chief General Reinhard Gehlen that turned over to nominal CIA control all of Nazi Germany's military intelligence in the Soviet Union and Eastern Europe.

In other words, Hydrick's contact is really saying that the CIA in all likelihood used Nazis to hunt other Nazis, a dubious enterprise at

best, and at worst an enterprise destined to uncover only what Bormann himself probably wanted to be uncovered. In any case, Hydrick was not thrown off the trail:

But if what Paul Manning and William Stevenson had written about Nazi international business activity was true, as he said it was, then the same assertions that Ladislav Farago had earlier written about it are likewise true, as is other very essential information about who they all agreed initiated the Strasbourg Conference (i.e. Bormann, ed). The effort to vilify Farago, therefore, was probably a smokescreen. With the knowledge my original premise was intact and there was now an effort being put forth to fog the truth, I put forth, more carefully, once again on this book.³⁸ The fact that the Nazi scheme had supposedly been put down was of no account to me; the confirmation that the Strasbourg plan was made and initially carried out is the cogent point for this volume. In later research I discovered, however, that the story about the financial properties being expropriated once and for all by the United States government, while true in form, was not true in reality. It was yet another effort to create a fog behind which the truth could be hidden.³⁹

But what was that hidden truth that the U.S. government, according to Hydrick, was trying to obfuscate?

Hydrick's answer is chilling:

The first is that Martin Bormann was the central player at the Strasbourg Conference. The second is that Bormann escaped Germany at the end of the war and lived for many years rebuilding and *controlling the economy of West Germany and much of Europe and Latin America, and that he did all this with the protection, support, and collusion of the United States government.*⁴⁰

Just why the U.S. Government would aid such a notorious Nazi as Martin Bormann in all this effort will be seen in the next chapter, but

suffice it to say, Bormann had learned the lessons of “leverage” quite well.

But what was all this effort to achieve? Hydrick’s answer is even more chilling still: the efforts were designed to achieve

A quick German rebirth and eventual European economic domination by Germany.... Strategies for covertly redeploying the economy...also included a “European economic community” that positioned Germany as the hub and “flag bearer” of a confederated Europe that would “predominate by ‘elastic political methods’... not with brutal force.” These elements are certainly recognizable in the history of post-war Europe as it actually unfolded, and, in fact, Germany continues with a high profile in the European economic model of today – which is truly a “European Economic Community.” The evidence reflects that the Flight Capital Program and Bormann’s partnership with I.G. Farben not only paid off as planned, but it set the foundation for the European economy we know today, and by extension that of the world.⁴¹

Just how true this is will be seen more completely when we examine the actual postwar political activities of the Nazi International in the second part of this book.

So what exactly was Bormann’s strategy?

It was a corporate version of the *blitzkrieg* itself, for by employing massive amounts of false fronts, dummy corporations, interlocking personnel in directorships with no known ties to major Nazi business combines, by using massive amounts of corporate “fifth columns”, Bormann hoped to orchestrate a vast network of corporate confusion that would take armies of finance agents and lawyers and years if not decades to sort out. And if the story of I.G. Farben’s fifty-plus year liquidation battle is any indicator, Bormann was wildly successful.

But this would require, as indicated, some sort of “leverage” as well, if one was to coerce the mighty American federal government into compliance. Just what this leverage might have been will be explored more fully in the next chapter.

The picture of Bormann the corporate manipulator that emerges from these considerations, however, should give one pause, for with Bormann one is dealing with the likes of a John D. Rockefeller or J.P. Morgan, but without their own “ethical constraints,” which were not that many to begin with. Bormann, as we shall learn in future chapters, had indeed not only positioned his Nazi International as a major global manipulator along side of those older vested international corporate and banking interests, he had to a certain degree also succeeded in penetrating them and using them for his own purposes.

D. Conclusions

As is by now evident, Allied claims to success in rolling up Bormann’s flight capital plan leave something to be desired. Indeed, one may question whether or not those claims are a smokescreen designed to hide something else. Just what that “something else” may be will be the subject of the next chapter, but suffice it here to state that these claims were quite wide of the mark. Bormann’s Nazi International not only survived, but survived in remarkably good organizational and fiscal health.

And as was seen in the present chapter, this organization and its flight capital program had the following goals:

- 1) Bormann basically confiscated any foreign reserves in the possession of German corporations and placed them under the control of the Nazi Party;
- 2) These funds in turn would be disbursed to corporations in aid of their fulfillment of the goals of the conference;
- 3) One primary goal was to establish “research bureaus” whose purpose, following the I.G. Farben N.W. 7 model, was to gather intelligence and steal foreign research as well as to conduct their own research;
- 4) Since these technical offices were to have their own Nazi Party liaison officer reporting directly to Bormann, it is clear that Bormann *intended* for his Nazi International to conduct not only espionage but *research* in its own right, under

departments of German corporations only very “loosely” connected to the Party in the surface, but deeply connected to it covertly;

- 5) Each such research bureau was to be established under a cloak of other activity, such as “investigating water resources;”
- 6) The capital flight program was designed to see to it that Allied authorities did *not* get the most valuable German scientists, technicians, or knowledge, as represented in patents, all of which were to be transferred overseas to safe havens, thus indicating that Bormann, in the light of all the previously enumerated considerations, intended for the Party to continue *an independent line of scientific research under its own control*, all the while managing and sharing any information gained through its espionage activities with the involved German corporations, as the Party and Bormann saw fit.

All this indicates that the Neo-Nazi science fiction novels of Wilhelm Landig were indeed “full of realities,” and that Martin Bormann fully intended to survive the war.

The only question is, did he?

As the next chapter will now argue, he not only did so, but did so in the company of other men whose presence in the Nazi International indicate that its objectives of independent Nazi control over the most advanced and arcane areas of physics research were alive and well, along with the men who coordinated them, secured the projects, and enforced the Nazi International’s policies abroad.

¹ Cited in Jim Marrs, *The Rise of the Fourth Reich*, p. 112.

² See my *Reich of the Black Sun*, pp 46-52.

³ For the full story, and an excellent recounting, of Von Manstein’s counter-counter offensive, see Paul Carrell’s *Scorched Earth*.

⁴ Figures of actual Soviet and German casualties vary depending on source.

⁵ Carter Plymton Hydrick, *CriticalMass: How Nazi Germany Surrendered Enriched Uranium for the United States’ Atomic Bomb* (Whitehurst and Company, 2004), pp. 184-185.

⁶ Carter Plymton Hydrick, *CriticalMass: How Nazi Germany Surrendered Enriched Uranium for the United States’ Atomic Bomb*

(Whitehurst and Company, 2004), p. 185.

⁷ Ibid., pp. 185-186.

⁸ Paul Manning, *Martin Bormann: Nazi in Exile* (Lyle Stuart, 1983), p. 39

⁹ Ibid., p. 44.

¹⁰ Manning, *Martin Bormann: Nazi in Exile*, p. 51.

¹¹ Ibid., pp. 51-52.

¹² Ibid., p. 53.

¹³ Manning, *Martin Bormann: Nazi in Exile*, p. 54.

¹⁴ Ibid., p. 59.

¹⁵ Ibid.

¹⁶ Ibid., p. 23.

¹⁷ Ibid.

¹⁸ Ibid.

¹⁹ Paul Manning, *Martin Bormann: Nazi in Exile*, p. 24.

²⁰ Ibid., p. 25.

²¹ Ibid., emphasis added.

²² Manning, *Martin Bormann: Nazi in Exile*, p. 25.

²³ Manning, *Martin Bormann: Nazi in Exile*, p. 25.

²⁴ Ibid., p. 26.

²⁵ Ibid.

²⁶ Manning, *Martin Bormann: Nazi in Exile*, p. 26, emphasis added.

²⁷ Manning, *Martin Bormann: Nazi in Exile*, pp. 26-27, emphases added.

²⁸ Manning, *Martin Bormann: Nazi in Exile*, p. 27, emphasis added.

²⁹ Manning, *Martin Bormann: Nazi in Exile*, p. 27.

³⁰ Ibid., p. 28.

³¹ Ibid., emphasis added.

³² Ibid., p. 37.

³³ Hyrdick, *Critical Mass*, p. 192.

³⁴ Ibid.

³⁵ Ibid., p. 190, emphasis in the original.

³⁶ William Stevenson, MI-6 agent and author of the book *The Bormann Brotherhood*, a book that maintains the postwar Nazi International's existence, and, moreover, its possible involvement in the JFK assassination.

³⁷ Hydrick, *Critical Mass*, p. 188.

³⁸ i.e., he set forth researching and writing *Critical Mass*.

³⁹ Hydrick, *Critical Mass*, p. 189.

⁴⁰ Ibid., emphasis added.

⁴¹ Hydrick, *Critical Mass*, p. 194.



**“The Postwar Survival of the
Unholy Trinity:”
The Escapes of Martin Bormann,
Heinrich Müller, and Hans Kammler**

*“Stalin told Harry Hopkins in Moscow that he believed
Bormann
escaped. Now he went further and said it was Bormann who got
away in
the fleeing U-boat. More than that Stalin refused to disclose.”*
William Stevenson¹

In a previous book, *Secrets of the Unified Field: The Philadelphia Experiment, the Nazi Bell, and the Discarded Theory*, I speculated on the possible survival of three top Nazis and what that survival portended in terms of potential implications. There I did not elaborate a case that those top three Nazis did in fact survive; that case is made here. But in order to appreciate the significant implications of that case, it would be worthwhile to recall what I wrote there for the benefit of readers who have not read that book:

As recounted in my previous books on wartime Nazi secret weapons research, *Reich of the Black Sun: Nazi Secret Weapons and the Cold War Allied Legend*, and *The SS Brotherhood of the Bell: NASA’s Nazis, JFK, and Majic-12*, much of the most highly classified Nazi secret weapons research, including their most highly classified weapon, the

Bell,² was coordinated by a super-secret think tank housed within the engineering division of the Skoda Munitions Works in Pilsen, Czechoslovakia.

SS *Obergruppenführer* Dr. Ing Hans Kammler headed the think tank. Born on August 26, 1901 in the German Baltic port city of Stettin, Kammler held a doctorate in engineering, and, by dint of his command of all German secret weapons research *and* of the SS' Building and Works Department, could tap into a slave labor pool of perhaps as many as 14 *million* people.³

Within the Skoda Works, Kammler had established a think tank whose mission brief was to map out technology trees for first, second, third, and even fourth generations of weapons of every conceivable variety, including nuclear weapons *and weapons far more destructive.*⁴ Since Kammler also spoke Czech, his choice of Skoda inside of Bohemian Czechoslovakia to headquarter his think tank was entirely logical, for Bohemia had been made a Reich Protectorate, and fell under the immediate jurisdiction of the SS. The SS had, in effect, turned all of Bohemia into a military reservation which to enter or leave required proper SS authorization and clearances. The SS had in effect turned a whole country into the Nazi equivalent of the Nevada test ranges. And within this already cloistered country, Kammler had turned the engineering division of the Skoda Works into the nerve center of a vast secret weapons empire, a veritable rats' run of underground laboratories and production facilities, many of which were never even known to Allied intelligence until after the war.

This think tank existed behind a triple belt of security. Indeed, the *Kammlerstab's* security is itself "the last piece of the puzzle," for as researcher Henry Stevens puts the case, it was a puzzle:

because Kammler's security was never breached. It was not breached by the U.S., British Intelligence or even Soviet Intelligence which thought they knew everything. Kammler was able to pull Alberich's Cloak of Obscurity over himself and his staff using a triple-wall of counter-intelligence units, the political

counter-intelligence unit, and the industrial counter-intelligence unit.

This security arrangement was so successful that when the Allies began advancing into Germany in the early spring of 1945, nobody asked the local population anything about Kammler or the Kammler Group. Neither side knew anything at all about it. By the time the “boots on the ground” realized who Dr. Kammler and his organization really were, his very name became a forbidden subject. This was probably so lest the other Allied Powers, especially the Soviets, learn of any potential treasure trove of scientific secrets.⁵

Moreover, this triple belt of security not only answered to Kammler, but to another notorious figure in the Third Reich, Heinrich Müller, head of the Gestapo, and whose very nickname “Gestapo Müller,” says it all. In any case, Stevens is correct; Kammler’s think tank was never penetrated.

This, from the historical standpoint, is an interesting association of names, for Müller in turn owed his promotion to the upper echelons of Nazi power to none other than Martin Bormann. Müller had, with Bormann’s connivance, turned a blind eye when as a local Munich police investigator he was called in to handle the suspicious suicide of Hitler’s niece and then mistress, Geli Raubal, prior to the Nazi assumption of power. There was strong evidence that Hitler had either deliberately murdered her, or in a fit of rage, had killed her. Hitler had called Bormann, so the story goes, in a panic. Bormann calmly told him he would fix it. Bormann then called Müller. And Müller suppressed the evidence, and for his efforts, became the chief of the notorious *Geheime Staatspolizei*. Small wonder then that, toward the end of the war, we find Bormann giving direct command of all of Germany’s heavy lift aircraft, the Luftwaffe unit *Kampfgeschwader 200*, to Kammler, which he then used to smuggle himself and Nazi Germany’s most sensitive secrets, including the Bell, out of Europe. Small wonder, then, that suspicions always abounded after the war that Bormann and

Müller had also escaped after carefully contriving their “deaths.”⁶

Bormann, Müller, and Kammler.

It is an interesting and unholy trinity to contemplate, for in it, one discerns the outlines of a very sinister shadow, the shadow of a post-war “Nazi International”, beginning to emerge. Consider: if there was to be a post-war Nazi International continuing to develop its own secret projects, it would need lots of money and someone who knew how to handle it: Bormann; it would need lots of security and someone who knew how to run it: Müller; and lots of engineering expertise and management experience in coordinating large projects and keeping them secret: Kammler. And they would need a suitably advanced project to work on within the limits imposed by post-war circumstances. Large uranium enrichment plants for a-bombs were out, as were large, and very visible rocket gantries. Something truly sensational, which would not require large physical plants (other than large power supplies), and which could pay much larger dividends than any other of the above alternatives, was needed: the Bell.⁷

This chapter is intended to argue the case that this “Unholy Trinity”, Bormann, Müller, and Kammler, survived the war. In section three the case will be argued that the physics the Nazi International continued to investigate was precisely the physics represented by the Bell, in fulfillment of Bormann’s directives at the Strasbourg Hotel Maison Rouge meeting to continue areas of independent Nazi research.

A. The Escapes of Nazi Party Reichsleiter Martin Bormann and Gestapo Chief Heinrich Müller

1. Bormann, Müller, and the Geli Raubal Affair

As noted in the extensive citation above, Martin Bormann and Heinrich Müller’s close friendship and professional relationship goes back to the Geli Raubal affair, and Bormann’s implied promotion of Müller to the position of head of the Gestapo. Müller’s card index file

system on individuals throughout Nazi Germany and occupied Europe was extensive and thorough, as was, of course, the extensive Gestapo counterintelligence network.

But the implications of this relationship are often overlooked. Bormann, who is known to have initiated no less than four investigations of Hitler's own family and presumptive Jewish background without Hitler's knowledge, most likely did so via the Gestapo and his contact with Müller. This Bormann-Müller relationship represented a vast potential for the power obtainable by blackmail and other means, and could, as the Geli Raubal affair suggests, include even Hitler himself.



*Reichsleiter Martin Bormann with Adolf Hitler;
Notably Bormann is seen here in a rare glimpse of him in his
SS Obergruppenführer's Uniform*

Bormann, through his contact with his friend Heinrich Müller, could have counted on the utmost discretion from the Gestapo's chief, since the latter owed his own position to Bormann's patronage, and both were in a compromised position vis-à-vis each other due to their roles in covering up the murder of Hitler's one time mistress.



Bormann in Nazi Party Reichsleiter Uniform



Heinrich “Gestapo” Müller

2. The Ladislav Farrago-Paul Manning Scenario

It is this Bormann-Müller nexus that forms the interpretive context by which to view the first scenario of Bormann’s escape, that presented by researchers and journalists Ladislav Farago and Paul

Manning. Both journalists made the claim that the information in their books was based upon confidential Argentine intelligence service documents, and Farago actually reproduced some of these in his famous book, *Aftermath: Martin Bormann and the Fourth Reich*. As Farago's book was called into question -though amply exonerated as Hydrick has already indicated – we shall rely here upon the assertions contained in Paul Manning's book, *Martin Bormann: Nazi in Exile*, reserving our detailed quotation and analysis of the Argentine documents for a later chapter.

a. Argentine Documents: Escape Via Genoa

According to documents cited by Paul Manning, Martin Bormann arrived in Argentina in 1948, via the ratline established through Genoa, Italy, on a freighter disguised as a Jesuit priest.⁸ He arrived in Buenos Aires, Argentina, and quickly established contact with business contacts of his "Nazi International."⁹ From there, Argentine intelligence agents successfully shadowed his movements in subsequent years throughout Brazil, Argentina, Paraguay, and Chile.¹⁰ Farago's documents substantially corroborate the broad outlines of this story.

For our purposes, it is important to note the European point of departure – Genoa, Italy – and the *modus operandi* of Bormann's escape: his disguise as a Jesuit priest, implying a measure of Vatican complicity, and Vatican diplomatic documentation, in the process. As will now be seen, this conflicts with other versions of his escape. The question is, can these various versions be reconciled?

b. Allen Dulles' Comment to Paul Manning

Paul Manning makes one highly significant comment in the Acknowledgments section of his book:

To Allen W. Dulles, for his encouragement and assurance that I was "on the right track, and should keep going," after reading my German research notes in preparation for this book,

during the afternoons we talked in his house on Q Street in Washington, D.C.¹¹

Dulles ought to have known, since he in part instigated the CIA's search for Bormann via his ostensible control over General Gehlen's organization in Eastern Europe, and later the CIA, of which Dulles was one time director until being dismissed by President John F. Kennedy for his part in the Bay of Pigs fiasco; the CIA pressured Gehlen to change the story for his memoirs. Manning notes that

The U.S. C.I.A., on the other hand, theorized that the Reichsleiter had succumbed to shellfire as he fled the bunker. Staunchly insisting that this was so, the CIA, for some unexplained policy reason, advanced, promoted, and encouraged this belief. They intervened, for instance, when General Reinhard Gehlen was arranging to publish his memoirs. Gehlen had run the German espionage network in Russia during World War II, and later, under Chancellor Konrad Adenauer during the cold war years, had served as chief of the German Federal Intelligence Service. The CIA obliged him to include a statement that Martin Bormann had been a Kremlin spy, and had died in Russia in 1969! I am told that the general complied with reluctance, but was indebted to the CIA; during the cold war they had funded his Eastern Europe/Soviet spy operation of 4,000 men at an annual cost to the U.S. taxpayers of around \$6 million. Back in 1953, his Bureau Gehlen had turned heaven and earth upside down for clues to Bormann's whereabouts in the East, reporting officially: "Bormann is not in East Germany or in the Soviet Union. The Bureau has been unable to discover what happened to him after he left the Reich Chancellery." Gehlen's credibility in knowledgeable West German political and espionage circles was damaged by this circumlocution. Called to Bonn to explain, he in essence retracted his statement.

My own West German sources had told me: "The CIA was behind the General Gehlen statement. It was a manipulation of public opinion by the CIA, immediately obvious to anyone who

knows anything about this subject. Bormann and his links to Germany today are a hidden but a very real political issue.”¹²

The CIA, through Dulles’ private comment to Manning, was wanting to have it both ways: publicly insisting on the truthfulness of the standard version of history that Bormann, along with Heinrich Müller, perished during their attempted escape from Berlin, and privately, through Dulles’ own comments, encouraging Manning that he was “on the right track.”

Why Dulles might have been so privately forthcoming to Manning is a matter of some speculation, but we can perhaps see Bormann’s own hidden hand in all these machinations, for clearly Bormann would not wish his survival and existence known, even in Germany. Hence, he would either have acquiesced in, or actively promoted, the standard history version. Indeed, as we shall discover a little further on in this chapter, there is every reason to believe that Bormann deliberately *created* and planted the evidence that would lead to that very version of his own escape! Dulles, who knew the truth but could hardly have revealed it without compromising or endangering himself, was perhaps quietly encouraging Manning in the hopes that this vast postwar plot would be exposed.

3. *The Carter Hydrick Scenario*

By far the most interesting, and to my mind, most probable scenario of Bormann’s escape was that reconstructed from careful consideration of the evidence by researcher Carter Plymton Hydrick in his crucial work *Critical Mass: How Nazi Germany Surrendered Enriched Uranium for the United States’ Atomic Bomb*. Hydrick’s own reconstruction of the motivations for the machinations on both the Allied and Nazi sides of their respective strange activities at the end of the War – and we shall see just how strange they really are in a moment – is evident from the subtitle of his work: those activities were necessary on both sides to conceal the fact that the Nazi government was turning over a massive supply of enriched uranium for America’s atom bomb project.

This implies two corollaries: 1) The Allied project was *not* as far along nor as near success as the Allied Legend version of atom bomb history maintains; and 2) the Nazi atom bomb project, conversely, was much *closer* to success – if indeed it was not already successful – in detonation of an atom bomb than public standard history would allow.¹³ As I demonstrate in my book *Reich of the Black Sun*, the Allied decision to pursue both routes to an atom bomb, i.e., a uranium bomb and a plutonium bomb, left American stocks of fissile uranium-235 well short of the needed critical mass as late as December, 1944, and these stocks, according to Manhattan Project documents themselves, would not be sufficient for a workable bomb until sometime in November of 1945, months *after* the detonation of the Little Boy uranium bomb over Hiroshima on August 6, 1945.

It is Carter Hydrick who explains *why* the Americans were able, in spite of these drawbacks, to detonate a uranium atom bomb over Hiroshima months ahead of schedule: the German U-boat, U-234, was carrying several kilos of highly enriched uranium-235 as part of its cargo to Japan, when suddenly, and without any explanation, that U-boat surrendered its precious cargo to American authorities. In other words, it was *German* enriched uranium that made the success of the Manhattan Project possible, and that meant in turn that the German program was much more successful than we have been led to believe. Just how this one lone U-boat managed to run the gauntlet of Allied naval forces in the North Sea, cross the northern Atlantic, survive numerous brushes with the Royal Canadian Navy, only to surrender to American authorities, remains to be seen, but there is one clue, and it lies, perhaps, once again in the technicalities of the German surrender.

a. And the Connection to the German Surrender

As noted in the first chapter, no representative of the National Socialist German Workers' Party was present at the surrender to the Allies and Soviets at either the Reims, France, or Berlin surrenders. Indeed, no representative of Martin Bormann's Party chancery was even *present* at those surrenders. As also noted in the previous

chapter, Bormann had gained control of a small number of *unregistered* U-boats, so-called “black boats”, for his own use and directly under his own control from Grand Admiral Karl Dönitz as early as 1943! In short, the Nazi Party *itself* had its own black submarine flotilla engaged in covert operations, responsible *directly* to Martin Bormann. And since that black submarine service in principle had not surrendered to the Allies at either of the two German surrenders via a Nazi Party representative, they were de facto still at war with the Allies.

These facts will assume great importance in our examination of Hydrick’s scenario.

b. Geoffrey Brooks’ Scenario: Invisible U-Boats

In order to appreciate the full significance of Hydrick’s scenario, it is necessary to view it in the light of information that is presented here courtesy of researcher Geoffrey Brooks, based upon his own examinations of Argentine and America archives and newspaper accounts. As will be seen, Mr. Brooks’ general scenario more than corroborates Hydrick’s meticulous reconstruction of the final events in Berlin, and the escapes of Gestapo Müller and Martin Bormann.

In a series of reports shared with this author, entitled “Report on Three Incidents Suggestive of Invisibility of German Submarines to Visual and Electronic Detection between 27 March and 4 July 1945,” Mr. Brooks details a number of encounters between Allied aircraft and German U-boats that do, indeed, pose something of a problem.¹⁴

As Brooks notes in his report, strange incidents accompanied the U-234, carrying the cargo of precious enriched uranium-235, as I noted in *Reich of the Black Sun*,¹⁵ as it ran the gauntlet of the dangerous sea passage of the Kattegat between Denmark and Sweden on its way to Norway on 27th of March, 1945:

From March 1945 to the end of the European War, the voyage from Kiel to Norway was extremely dangerous for German submarines. The RAF had air supremacy over the western Baltic and kept a tight watch over the waters. All

German submarines leaving Germany for Norway had to pass through the Kattegat between Denmark and Sweden. The Kattegat is a narrow stretch of water easily mined and blockaded. More than half of the submarines attempting the passage were sunk by aircraft. Only one submarine in four made the run successfully without receiving serious damage.

Electronic Detection Devices: Most RAF aircraft were equipped with airborne radar enabling them to accurately fix German submarines. A few important U-boats leaving Germany had one or other FuMB anti-radar warning devices installed. These could detect at long range the approach of enemy aircraft and warships emitting radar beams.¹⁶

Brooks notes that the U-234, a massive type XB cargo-carrying U-boat displacing some 2,700 tons submerged and capable of a cruising range of some 21,000 sea miles at 10 knots – well able to handle its intended mission to Japan – departed Kiel on March 26, 1945, carrying “eleven scientific-military passengers” which included “two Japanese and six Wehrmacht officers,” all of whom outranked the U-boat skipper, *Kapitänleutnant* Johann Fehler.¹⁷ As I noted in my book *Reich of the Black Sun*, this cargo also included some 80 gold-lined cylinders full of enriched uranium-235, the plans and a complete model of the Messerschmitt 262 jet fighter, plus German infrared proximity fuses and their inventor, Dr. Heinz Schlicke, fuses that in all likelihood made America’s successful detonation of its plutonium bomb later that year successful.¹⁸

Then, on March 27, 1945, at 1500 hours (i.e., 3:00 PM central European Time), the U-234 recorded the first of many strange incidents on her strange voyage. According to Brooks:

(1)...three enemy aircraft were sighted ahead and the flak guns were manned. As the range decreased from 5000 yards, Oberfunkmeister Wolfgang Hirschfeld relayed the distances to the bridge. At 3000 yards, Fehler gave the order to open fire. Hirschfeld was in the radio room and heard the commander give this order. The flak guns did not respond. Hirschfeld ran to the bridge and saw Fehler pleading with the gun crew to open fire, but they ignored him. The enemy

aircraft now flew over the string of four submarines and were apparently unaware of their presence.

(2) At midnight on 27 March 1945 off Frederikshavn(sic) the four U-boats passed a convoy of four steamers, with torpedo boats as escort, heading southwards for Germany. RAF aircraft fired flare clusters to bathe the seascape in a pale light then attacked the steamers. They appeared to overlook the four U-boats, the priority target.

(3) A half hour later the U-234 anti-radar showed that the Kattegat was now swarming with enemy aircraft. A machine was identified approaching at low altitude from the west, barely skimming the surface. At 3300 yards the aircraft veered away. Thirty minutes later another bomber came in from the same direction and again disengaged at 3300 yards. "The game went on all night," Wilfgang Hirschfeld wrote, "it was repeated three times. It could not have been coincidence." (on the) new morning all four U-boats arrived undamaged at Oslo Fjord.¹⁹

Mr. Brooks is correct: under normal Allied operating procedures, the U-boats in the small submarine convoy which included the U-234 would have been attacked by Allied aircraft. On no less than three occasions, however, the aircraft came within easy visual range of the convoy, illuminated it with flares, and yet, inexplicably, did *not* attack. Why?

Mr. Brooks' own answer is illuminative of one possibility:

(i) Numerous details regarding this voyage remain top secret. An apparently innocuous fact which remains secret is the data respecting the fuel aboard U-234: how much was loaded, how much expended. In both the other cases to be mentioned, the boats loaded inexplicably up to 35% short "to maintain stability."

(ii) Why did the flak crew disobey the commander? Either the flak gunners were affected mentally while inside the energy field, or perhaps (the U-boat captain) had forgotten that a more senior officer had full authority over the "special equipment"?

(iii) On two occasions – the first encounter and in the flare-light at night – the submarines appear to have been invisible to

the eye and enemy radar.

(iv) The last contacts appear to suggest that the submarines were now being seen on radar – perhaps the energy field was weakening – but as they entered the field the aircraft functions were jeopardized in some manner - “if your aircraft starts to run rough for no apparent reason, pull away.”²⁰

It is clear what Brooks is implying: the U-234 and its companion U-boats may have been outfitted with some special radar-cloaking electronic equipment, devices which may have rendered them optically and radar invisible to Allied aircraft. As a result of the strong electromagnetic field these devices undoubtedly set up, the German flak crew on the deck of the U-boats – remember they were running on the surface – may have been affected by this field in some strange way. Or, as Brooks also suggests, they may have been under orders not to fire from officers senior to the U-234’s commander, Captain Fehler. The presence of such equipment on these U-boats, Brooks implies, may account for their not loading the full complement of fuel, for they were unable to do so with the heavy electrical equipment on board.

While all this may sound far-fetched, it is indeed not beyond the bounds of possibility. As I demonstrated in my previous book, *Secrets of the Unified Field: The Philadelphia Experiment, the Nazi Bell, and the Discarded Theory*, one and the same physics underlay the U.S. Navy’s infamous Philadelphia Experiment, an experiment that indeed purportedly made a U.S. destroyer escort optically invisible, and the Nazi Bell. If the Germans had configured radar equipment to be beamed on the Bell while it was in operation, they may indeed have discovered some profound radar cloaking properties being produced by the device. While there is absolutely no evidence to suggest that the Nazis did such a procedure, or that they performed any such experiments, it is known that they *did* conduct top secret radar tests on their Radar Absorbent Material (RAM), during the same time period of the war,²¹ and additionally, the German *Kriegsmarine* itself was represented in the Bell project in the form of the German “Admiral Rhein” in the Bell project’s parent organization!²² As I also pointed out, the legend of the Philadelphia

Experiment does include allegations of strange mental and physiological behaviors being induced in the people exposed to the field allegedly established during the experiment.²³

Brooks records yet another peculiar incident involving a U-boat and its strange “invisibility” to Allied radar-equipped aircraft. The famous case of the U-977, one of the U-boats that surrendered to Argentina long months after the war in Europe had ended, began her voyage in a similar fashion to the U-234:

In the third week of April 1945, U-977 sailed for Norway in a convoy of three submarines. At Frederikshavn provisions were loaded. Combined with the assumed heavy load already aboard, the boat was now overloaded, and the Chief Engineer warned that it would be difficult if not impossible to maintain the trim when diving. OKM (*OberKommando der Kriegsmarine*, German Naval High Command, ed.) had ordered that the voyage should be accomplished at schnorchel depth, but Schäffer decided to proceed on the surface and alone because his crew was inadequately trained on the schnorchel.

After leaving Frederikshavn, an enemy night attack came when U-977 was navigating in the heavily mined shallows and could not dive. The anti-radar gave warning of enemy aircraft. The enemy aircraft were therefore equipped with radar. Schäffer counted twelve, approaching fast. He heard the noise of their engines. The aircraft circled interminably, apparently unable to get a proper fix on the surfaced submarine. They would attack with rockets which sliced through the hull of a submarine and thus sink it when the time came. No attack came, and after a few hours when U-977 left the shallows, Schäffer dived. The anti-radar showed that the aircraft followed him, but did not attack.²⁴

As Brooks notes elsewhere in this part of his report, the U-977 was an older type VII U-boat, and its intended mission in 1945 was to sneak into Southampton and sink Allied shipping, a suicide mission for a type VII (especially when many of the much newer Type XXIII electro-boats with their novel, and *quiet*, propulsion systems

were available for this type of attack) *unless* the U-977 was equipped with special experimental cloaking equipment.

But might there have been a different kind of “invisibility” operating in these late war encounters between German U-boats and Allied aircraft?

c. Hydrick on the Surrender of German A-Bomb Secrets and Enriched Uranium-235: “Invisible” U-Boats Reconsidered

(1) The Official Versions, and Their Problems

Indeed, there might have been, and the name of that special kind of invisibility was called “Martin Bormann,” and an implied and highly covert, above-top-secret deal that he might have negotiated with the Americans as the European War drew near its end. And it was, as we shall see in a few pages, a deal that had to have “teeth” in order to persuade the Americans of its *bona fides*, enough teeth to make sure they lived up to their part of the bargain.

And with this we are confronted with the escapes of Martin Bormann and Heinrich Müller, and the deal, seen in the total context of Bormann’s strategic evacuation plan, that they brokered and that their escapes signify. Hydrick’s is the most meticulous reconstruction of this probable escape scenario, and of what its real, and continuing, implications are.

The story begins, once again, with the U-boat U-234, and its precious cargo of infrared proximity fuses and enriched uranium-235. The story of Bormann’s role in this voyage, and of his probable escape from Berlin, is not without its own difficulties. As Carter Hydrick himself observes, it is when pondering Bormann’s “death” or “escape” itself that the whole hornet’s nest of problems really begins to buzz:

For over fifty years a debate has raged about whether Martin Bormann escaped from Berlin in the spring of 1945, whether he was killed in a fiery explosion on Weidendammer Bridge in that city,²⁵ or whether he mysteriously died a few hours later at the

Lehrter Station Bridge a few miles away.²⁶ Over that half-century, so many accounts of his last days in Berlin have been generated, fabricated, amended, modified, denied, rebutted, investigated, expunged, reborn, reshaped and abridged that nothing is certain but a black mist of confusion and suspicion that hangs over the whole affair like a thick pall. Indeed, the truth may never be known. Not just because the evidence supporting any outcome is inconclusive, but because there seems to be few participants who were or are objective on the matter, and therefore the testimony and evidence they provide must, for prudence, be viewed with varying degrees of skepticism. What is known, despite the bleak picture that is always painted of these events, is that 90 percent of those who were in the bunker at the end of the war survived.²⁷

Just how much of this thick black pall of confusion was of Bormann's and Müller's own making remains to be seen, but whatever the standard versions of history that quickly began to be pushed by the Allies publicly, it is significant that the Nuremberg War Crimes Tribunals weren't buying, for they tried, convicted, and sentenced Bormann to death *in absentia*, for good measure, just in case he should resurrect himself from the Weidendammer Bridge or the Lehrter Station – or wherever – and return in an unbidden and unwelcome second coming.

For Hydrick, however, the events of Bormann's last days in Berlin and the voyage of the U-234 with its precious cargo are intimately connected, and to show how, Hydrick first discloses the complex methodology that informs his own reconstruction of Bormann's and Müller's escapes:

The evidence, in fact, is significant in support of both theories (of his death and of his escape), and, despite claims of certainty by both camps, a detailed study of all the data available tends to muddy the already shadowy history beyond ever finding certain resolution. Indeed, there is strong evidence the waters were muddied intentionally by those who merely had to make his fate questionable, in order to win their objective of

invalidating any reference to Martin Bormann in post-war history. But by filtering all of the available information through two criteria, one may possibly gain, if not a crystal clear understanding of the outcome of events, at least the most probable outcome of Bormann's last days in Berlin.²⁸

That probable outcome according to Hydrick is clearly that Martin Bormann escaped to safety, most likely in the company of his friend and fellow bunker escapee, Heinrich "Gestapo" Müller.²⁹

The two criteria are clearly spelled out by Hydrick. One of them looks

At dissociated stories surrounding these events and see(s) what parallels might verify each other to validate details. The more numerous and specific the evidentiary pieces paralleled, the more probable that they are true – assuming they are not totally invalidated by known facts.

The other (criterion) is that of judiciously weighing the evidence against who presented and/or supports it – and why – in an effort to identify and properly interpret political and other influences that may have colored the information presented. *By combining these two methods of analyzing the information, a more coherent and believable – in fact, this author believes, probable, though disturbing – case for Bormann's survival is formed, rather than the accepted scenario of his death.* Let it be noted here, however, that this author does not believe this evidence is conclusive. I believe only that the evidence is significant and superior for Bormann's survival over the evidence of his demise in Berlin. *And that evidence shows U-234 was related to his escape....*³⁰

Needless to say, Hydrick's evidence, when combined with other evidence of Nazi survival in general, as well as Bormann's survival in particular, to be presented in this book, in my opinion argues quite strongly, though again not conclusively, that Bormann and two other top Nazis essential to the postwar program of his Nazi International

did in fact survive the war: Heinrich “Gestapo” Müller and SS General and secret weapons projects head Hans Kammler.

The standard version of Bormann’s and Müller’s escape from the *Führerbunker* beneath the Reichschancellory building is by now familiar territory to most World War Two researchers. Sometime during the late hours of May 1, 1945, after Adolf and Eva Hitler’s alleged suicides, the remaining bunker party divided themselves into small groups and snuck out of the bunker during the night, under a constant hail of Russian artillery and small arms fire. “Each group was responsible to find its own way to safety.”³¹

In one of these pathetic patrols reportedly stalked the potbellied, short-legged, bull-necked profile of Marti Bormann, commander of the Nazi party and Hitler’s closest confidant. According to the provided scenario, the small group slowly picked its way through the bombshells, bodies and debris littering the streets to a local subway station, where, once again, it slipped under cover of earth. Walking the rails in the dark subway tunnels, the silent group made its way north, where it again surfaced to find means to cross the Spree River.

At Weidendammer Bridge the group ran into heavy fighting between German tanks and Russian forces. One story asserts that Bormann tried to cross the bridge under cover of a German tank navigating the narrow span. The tank was shelled by a bazooka and exploded in a violent burst of flame, killing Bormann according to “eyewitness” Erich Kempka, Hitler’s chauffeur and a member of the Fuehrer Bunker escape party.³²

At least four other “trusted Hitler insiders” also reported seeing the same event, with the same results.³³

But then the story started, almost immediately, to spin out of control, as new witnesses surfaced with new and in most cases contradictory details. One of them, a Spanish SS volunteer and avowed Nazi, was fighting as part of a small SS detachment near the bridge. He saw the rocket shell from the bazooka hit the German tank, and explode. The Spaniard, Juan Roca-Pinar, then boarded the tank, opened the hatch (apparently the German crew had forgotten

to bolt it from inside, an unlikely event in a combat situation!), and discovered Bormann dead inside the tank.³⁴ Roca-Pinar's story was corroborated by a Harald Mengerhausen, a member of Hitler's bodyguard, who likewise stated that Bormann had been in a tank, but that Bormann was not killed in the blast because he had been in a *different* tank altogether!³⁵

From here, the standard history quickly deteriorates. For example, Artur Axmann, leader of the Hitler Youth, "Claimed to have run into Bormann *after* the Weidendammer Bridge catastrophe and asserted that Bormann was alive, well and completely unharmed."³⁶ Axmann and Bormann, according to this version, then made common cause in their escape for a brief moment, before they separated "to search for their own passages to freedom."³⁷

And then, things get even stranger:

Axmann headed west, but, finding the way blocked, subsequently retraced his steps and claims to have again come across Bormann and Dr. Stumpfegger, one of Hitler's physicians, on a railroad trestle at the Lehrter Fairgrounds train station. Bormann and Stumpfegger were lying side by side on the bridge and appeared to be dead. Axmann leaned close to Bormann's body to check for breathing and could discern none. He later would not swear with certainty, however, that the Reichsleiter had expired.

Indeed their "deaths," if they were dead, were strange. According to Axmann, neither corpse showed any indication of being wounded or injured or showed any signs of violence – quite out of line with the reports from Weidendammer Bridge, even if Bormann had survived the tank blast, and further mystifying given their deaths having taken place during a heavy battle. They lay calmly next to each other in peaceful repose, their arms resting casually at their sides, as if they had laid down on their own, or somebody had laid them there. Axmann wondered if they had been poisoned or poisoned themselves.³⁸

Hydrick's conclusion about the two official standard versions is worth citing:

And so the semi-official version of Bormann's demise is dubiously documented in a melee of misaligned explanations and seemingly unexplainable inconsistencies. The picture would get further obscured. A rash of post-war Bormann sightings across Europe began to be reported. He was in Sweden, Italy, Spain, Denmark, Germany, Switzerland, Norway, even as far away as Argentina.³⁹

But why insist that the documentation itself is dubious, as Hydrick does?

For a very simple reason: all of the eyewitness reports of Bormann's demise come from Nazis themselves. And that fact raises the even more problematic question of how a story based on the eyewitness testimony of Nazis became in effect the standard view of history for the victorious Allied Powers. That question will, upon reflection, bear obvious implications for the similar question of the story of Hitler's suicide, for once again, all of the eyewitness testimony comes precisely from Nazis.

In any case, the official versions of Bormann's feat of dying twice, once at the Weidendammer Bridge (under two very different conditions), and again at the Lehrter Fairground railway station, were soon further compounded by so-called forensic evidence literally unearthed decades after the event. Reports soon circulated that the Russians had found Bormann's body exactly where Axmann said it would be and quickly identified it as Bormann's because it contained Bormann's journal, conveniently found in the dead gentleman's now much decayed overcoat.⁴⁰ Joy and relief were quickly dispelled, however, when it was disclosed that the Soviets had "quickly surmised that the diary had been *placed* in the overcoat to lead investigators off of Bormann's trail."⁴¹

To make matters worse, in late 1972,

Just as two separate articles by Ladislav Farago and Paul Manning began being published that convincingly argued that Bormann had escaped Berlin, a construction crew "accidentally," and under suspicious conditions, unearthed two skulls and

some bones 20 yards from the location previously dug up by the official Bormann search party....

The skulls were examined to see if one was Bormann's but there was a problem: no records of Bormann's dentistry or any other identification marks existed that could be compared against the skeletal remains. The only record available was a sketch drawn from memory by Bormann's by-then-deceased dentist, Dr. Hugo Blaschke, who drew the sketches during interrogation for the Nuremberg trials. The accuracy of the chart was attested to by Fritz Eichtmann, a dental technician who had never actually seen Bormann's teeth, but who had built a dental bridge for a patient he "assumed" was Bormann, based on data given by Dr. Blaschke. Using this data, the pathologists in the case compared the sketch with the unearthed skulls and proclaimed a match with one.⁴²

There was just one problem: "the skull may not have been Bormann's" because the Soviets had, in fact, re-buried the Bormann corpse *they* had found in a different location.⁴³

As if that were not enough, the skull conveniently discovered by accident went through no less than four different iterations, "each succeeding cranium becoming more and more aligned with the dental sketch of Dr. Blaschke as succeeding complaints came in about obvious inconsistencies."⁴⁴ But then the final word came in May of 1997, when DNA tests were conducted on the skull and "a positive identification announced in May 1998."⁴⁵

Except that the specific DNA results were never released.

And also, except for the fact that the provenance of the skull was not impeccable.⁴⁶

And also, except for the fact that the disposition of those who controlled the skull is not established beyond any doubt as being completely neutral.⁴⁷

And also, because the skull's whereabouts for almost two decades was unknown, from its disappearance in Soviet hands after its reburial, to its rediscovery some yards away from where it should have been.⁴⁸

All of this, as Hydrick rightly quips, “combine to cast more than reasonable doubt, not so much upon the authenticity of the DNA tests, which, as demonstrated, could have gone either way, but upon whether they have any relevance in the matter at all,”⁴⁹ for it would be a simple matter for the skull to have been planted long after Bormann’s demise, whether in 1945 or later, and given the skull’s unknown location for twenty years, it is a distinct possibility.

(2) *Obfuscating the Data and Confusing the Trails: Doubles*

So what of the dental records? As Hydrick observes, it would not have been a difficult matter to find one or two (or three) Bormann look-alikes, *Doppelgängers* or body doubles, alter those individual’s dental records, and have them all escaping at convenient times from the Bunker in order to deliberately confuse the trail. And as for DNA evidence, that too, may be a bit problematical, as Hydrick suggests:

One last possibility is worth mentioning, however, regarding DNA testing of the skull. If the Soviet report is wrong and the skull tested for DNA was actually that of the person buried in Lehrter Station with Dr. Stumpfegger, it may well have been that of Bormann’s double. (Heinrich “Gestapo”) Mueller had successfully found a double for Hitler in one of the Fuehrer’s distant cousins. Might he have done the same for Bormann when developing Bormann’s double? James O’Donnell, author of *The Bunker*, noticed on a personal visit to Bormann’s hometown that a large percentage of the people there looked like Bormann, and were possible relations. If the body was that of a Bormann relative, DNA tests quite possibly would have shown similar markers with the DNA provided by another relative, without the skull being that of Martin Bormann.⁵⁰

When all is said and done, the DNA testing has done little to advance either the scenario of Bormann’s death-while-escaping, or that of his survival. It has merely highlighted in a major way the lengths to which Bormann and Müller themselves possibly went to obfuscate the data and confuse the trails.

It might be argued that this speculation that the Nazis deliberately deployed Bormann relatives to confuse such future genetic identification of any dead “body doubles” is anachronistic, since the DNA helix itself would not be officially discovered until two years *after* the end of the war, in 1947, by Watson and Crick. However, the Nazis had done enough genetic research of their own, I believe, that the case can be argued that they would have known the code would inevitably be cracked, and usable as a means of identification with enough technological development.

In any case, Hydrick’s mention of O’Donnell’s visit to Bormann’s hometown, and his observation that the males of the town, distant Bormann relatives, all looked like the infamous *Reichsleiter* himself, throws open yet another possibility that Hydrick does not mention, but which thoroughness requires be stated. Bormann was indeed sighted all over Europe and Latin America in the years immediately following the war, and for some time afterward. It would not be beyond the bounds of possibility – and assumes great significance if indeed Bormann did in fact survive – for Müller to have employed *several* Bormann look-alikes to create several false trails, serving to obfuscate the picture even more, while simultaneously cloaking the *Reichsleiter’s* real movements and whereabouts. This possibility will assume some significance as the various escape scenarios are analyzed later in this chapter.

(3) *The Hydrick Scenario*

(a) *The Movements of Martin Bormann and Heinrich Müller*

So, how did Martin Bormann escape?

As Hydrick observes, Stalin believed, on the basis of Soviet intelligence reports, that Borman flew out of Berlin close to dawn on April 30, 1945. According to these reports, three men and a woman were flown out on the small plane, supposedly flying in the direction of Hamburg. The Soviets also noted the departure of a “large U-boat” from Hamburg before the British army arrived to capture the city.⁵¹ Stalin informed Harry Hopkins in Moscow that he believed that Bormann was one of those who escaped on that fleeing U-boat.⁵²

More importantly, “Stalin insisted until his death that his was the correct account of Martin Bormann’s fate.”⁵³

Hydrick then asks, and answers, three all-important questions:

Why would Stalin make such a claim? What did he stand to gain if it was a lie? What did he stand to lose if it was true? And if it were true, why would the United States discount it out of hand?... If Stalin was not telling the truth, why did he include such unique, improbable and seemingly contestable details as the fact that the airplane carried four people when the only two airplanes capable of using the ad hoc runway – the Fieseler Storch and the Arado – were designed, respectively, to carry three and two people. Depending on which witness tells the story, both the Fieseler Storch and the Arado are said to have been the escape airplane. Why did Stalin include a woman in the escape party when it was almost inconceivable that a woman would be so important as to justify overloading the plane on this desperate and dangerous mission? And why would Stalin assert the escape was continued from Hamburg on a “large” U-boat? The chances seemed slim that such an escape as Stalin described was ever made.⁵⁴

However, a number of allegations in Stalin’s version are indeed oddly corroborated by the facts themselves.

In the first instance, it is known that a makeshift runway was indeed operating from the Tiergarten during the last days of the war in order to shuttle important visitors and other items into, or out of, the *Führerbunker* in the final days of the war. As Hydrick observes, however, at the time of Stalin’s alleged remark to Harry Hopkins, that fact was not well-known.⁵⁵

Secondly, as is now well-known from the standard versions of Hitler’s suicide, the famous German test pilot Hanna Reitsch had flown a Fieseler Storch bearing Luftwaffe General Robert Ritter Von Greim to Berlin only a few days prior to April 30th, an event memorialized, in fact, in the famous movie *Hilter: the Last Ten Days*, starring Sir Alec Guinness as an increasingly derranged Hitler.

According to the standard historical line, followed closely in the movie, Hitler had ordered Von Greim and Reitsch to make the dangerous flight simply so that Hitler could appoint Von Greim to be the chief of the now nearly non-existent Luftwaffe after Hitler ordered Göring deposed from all positions for attempting to take control of the government.⁵⁶

According to Reitsch herself, she and Von Greim flew out of Berlin at dawn on April 30th, 1945 – the same date and time as Stalin’s version of Bormann’s escape by airplane from Berlin, and made their way to Admiral Karl Dönitz’s headquarters at Plön. Reitsch gave as their reason for this flight plan as “fulfilling an order from the Fuehrer to deliver an important package, and the desire to wish the Admiral a fond farewell.”⁵⁷ Obviously, the idea of bidding “fond farewells” to the Admiral is laughable on the face of it, but the idea that Reitsch and Von Greim were fulfilling an order of Hitler to convey an important package, “especially if the package was Martin Bormann with Hitler’s last will and testament,” which documented Hitler’s decision to turn over political and military command of the Reich to Dönitz, does ring true.⁵⁸ “The traditional history,” notes Hydrick,

Documents well Bormann’s intense efforts to make his way to Admiral Doenitz during this time. Bormann had told his family they would be escaping on a U-boat to Japan, and some of Borman’s closest associates, including Gauleiter Erich Koch and others, expected to escape by U-boat as well, with Bormann’s help. So strong was Bormann’s effort to reach Doenitz that by 3:30 the morning of 30 April, Bormann had convinced Hitler to issue an order to his pilot, Hans Baur, to fly Bormann to Doenitz.⁵⁹

So Bormann was indeed attempting to escape Berlin, *not on foot as recounted in the standard histories, but by aircraft from the makeshift runway at the Tiergarten.*

But there is another escape from Berlin by air that should be noted. As already observed, in Stalin’s version, *three* men and a woman are on the flight carrying Bormann out of Berlin. If, then, Bormann escaped on the flight with Reitsch and Von Greim in the

three-passenger Fieseler Storch, then this would only account for two men – Bormann and General Von Greim - and Hanna Reitsch herself, piloting the craft. If there was a *fourth* person, the identity remains unknown, though Gestapo Müller is a distinct possibility.⁶⁰ This is where the other escape flight from Berlin comes in.

According to alleged interrogation records of Gestapo Müller from 1949 – four years after the Gestapo chief’s “official” death while escaping Berlin – Müller described his flight from Berlin on April 29th in a Fieseler Storch piloted by one pilot.⁶¹

This flight does strongly suggest that Müller was the fourth party on the Reitsch flight for the following reasons:

First, If Bormann and Mueller did escape secretly in company of Reitsch and Greim, it would seem that as joint conspirators and protectors of the post-war Nazi cause they all would have agreed to eliminate each other’s escapes when reciting their own cover stories. For this reason, Reitsch would not have identified Bormann or Mueller as having been on the flight she piloted to Doenitz. Under the same agreement, Mueller would not have identified any of his flying mates either; therefore he reported he flew alone.⁶²

In other words, to make the stories of Müller’s and Bormann’s escape by ground – the standard version of history – seem plausible, agreed-upon cover stories had to be concocted before the flight itself occurred, and this could only be done by Reitsch’s and Von Greim’s physical presence in Berlin in the bunker, with Bormann and Müller briefing the other two on the plan.

But what has all this to do with the “large U-boat,” the U-234, and its cargo of infrared proximity fuses and enriched uranium?

As Hydrick points out, the U-234 was the only boat of its size “left in the Atlantic theater,”⁶³ probably making it the boat in question in Stalin’s account. But there is more tying Bormann and Müller to the ship, for there were two communications from the *Führerbunker* directly regarding the departure of the U-234 as will be seen in a moment. Moreover,

Captain Fehler appears to have taken U-234 on a convoluted voyage, with each successive twist and turn apparently intended, at first, to keep U-234 within a few days' proximity to Germany, and later, to hide the U-boat's movements and activities as it tried to surrender only to the United States.⁶⁴

So exactly what was happening to the U-234 from the time of her departure from Kiel on March 25, 1945,⁶⁵ and the flight of Hanna Reitsch, General Von Greim, and in all likelihood Martin Bormann and Heinrich Müller?

Captain Fehler ran the U-boat on the surface out of Kiel, and once in the open waters of the Baltic, it was joined by two more U-boats for the first leg of the journey to Norway.⁶⁶ Waiting until the cover of darkness, U-234 and her escorts began the first part of their journey after being joined by three more type XXIII electro-boats. Once through the narrow straits between Sweden and Denmark, the two original U-boat escorts dropped off and the U-234 and the three type XXIII's continued under the cover of darkness through the Kattegat, hugging the coast of Sweden and doing about 10 knots.⁶⁷ It was here that the U-boats had their strange encounter with the Allied aircraft⁶⁸ observed by Geoffrey Brooks earlier in this chapter.

But now Hydrick offers a different account of the small flotilla's apparent invisibility to the Allied aircraft:

The enemy air patrol may have been on a dedicated mission elsewhere and simply was not interested in the mini-armada. *Or the aircraft may have been ordered only to reconnoiter the U-boats but not attack, an odd but plausible scenario given ensuing events.* Whatever the case, the U-boats continued their course toward Norway.⁶⁹

To put it differently, Bormann, who had offered the Americans the enriched uranium-235 and priceless infrared proximity fuses aboard the U-boat, in return for his own escape, had also given them highly secret information concerning the U-boat's course. And the Americans, for their part, informed their British Allies to have their

aircraft monitor the U-boat's course, but not to attack, most likely concealing from them the real reason for the strange orders.

Hydrick also recounts the similar near approach of the Allied aircraft on no less than three occasions, and the similar breaking of attack, as mentioned previously by Brooks.⁷⁰

That no effort was made to sink U-234, but several attacks appear, in fact, to have been suppressed, suggests that, instead of wanting the vessel and its contents and passengers destroyed, the U-boat was being monitored and its passage protected at a high level within Allied command, for some unknown purpose. Obviously, if U-234's progress was being tracked and protected by the Allies, probably the crews of the attacking aircraft would not have known it. But if there were those in higher Allied circles who knew of and expected to obtain U-234's uranium cargo, certainly they would have kept a close eye on its whereabouts and the conditions under which it was traveling – and had channels to the proper authorities necessary to divert disaster if required.⁷¹

The air attacks thus averted, the U-234 and her escorts arrived in Oslo fjord shortly before sunrise on the 27th of March, 1945.⁷²

There the U-boat underwent minor repairs for the lengthy journey to Japan, while its radio operator Wolfgang Hirschfeld journeyed each day to retrieve radio messages for the U-234 from the U-boat radio operations center at Kristiansand. During one of these visits shortly after the U-boat's arrival in Norway, Hirschfeld claimed to have received a short communication:

U-234. Only sail on the orders of the highest level. Fuehrer HQ.⁷³

In short, the *Führerbunker* had now taken direct control of the U-234 from Admiral Dönitz. As will be seen in a moment, this did not sit too well with the Grand Admiral.

At this point, the story of the U-234 becomes downright bizarre by any standard line of explanation, for later that same afternoon,

Hirschfeld was summoned to the flotilla headquarters once again to explain the latest radio message it had received for the U-234. Hirschfeld was accompanied by the Second Watch Officer Karl Pfaff, who was in charge of loading the U-boat, and thus who would have known something about its treasure-cargo.

The message they were summoned to explain stated:

To head radio chief Hirschfeld on U-234, for your last trip, much luck and healthy return home. Your Bubbi.⁷⁴

The flotilla commander demanded Hirschfeld explain who “Bubbi” was, and Hirschfeld’s explanations leave a lot to be desired, for he told the commander that it was the nickname of the radio operator of the U-boat base in Lorient, France, which had long since fallen to the Allies.⁷⁵ Clearly, Hirschfeld was protecting highly privileged and secret information.

As Hydrick observes, it appears that a highly secret line of communications had been established prior to the boat’s departure from Kiel, directly between the U-boat captain and its radio operator, Hirschfeld, and Berlin itself, bypassing Grand Admiral Dönitz completely, and using frequencies “which U-234 was incapable of receiving,” explaining the necessity for Hirschfeld to journey to Kristiansand to pick up messages for the ship while it was undergoing repairs. Or, perhaps, the system had been established to avoid disclosing the confidential messages to normal U-boat command, i.e., Grand Admiral Dönitz.⁷⁶

In any case, later in the day Hirschfeld was *again* recalled to the radio center to retrieve yet another message, this one directly from Dönitz himself: “U-234 is to leave under my command only. After you have made your calculations, leave. BdU.”⁷⁷ As Hydrick observes, the designation BdU was Dönitz’s personal command designation. “Doenitz’s message makes clear,” notes Hydrick, “that a struggle for control of U-234 was taking place, for, as the supreme commander of the German Navy, why else would the Admiral have to remind one of his captains to depart only on his command?”⁷⁸ It is even likely, according to Hydrick, that the contents of the mysterious “Bubbi” message was relayed by the local flotilla commander to Dönitz,

making him aware of a parallel chain of command that someone in Berlin was attempting to establish over the U-boat.⁷⁹

All this sets subsequent political events into a very different perspective:

Ultimately history records that Martin Bormann, from the besieged bunker in Berlin, spent considerable attention on negotiations with Doenitz in order to effect his escape from the strangling city. And it records that Grand Admiral Karl Doenitz, without political experience or, indeed, any political following, eventually, and very unexpectedly, replaced Hermann Goering – whom Bormann had succeeded in bringing down as Hitler’s successor – when Bormann notified Doenitz that the Admiral was to succeed Hitler as Chancellor of the Third Reich.⁸⁰

Given the U-234’s cargo of enriched uranium-235, highly suspicious Allied air attacks on the U-boat that never materialized, and Dönitz’s own succession to Hitler, communicated to him by Bormann himself, we can now see the hidden politics being played out as Bormann attempted to commandeer the U-boat for his escape, while ensuring its cargo reached its real intended destination: not Japan, but the United States. Someone at high levels on both the American and Nazi sides of the war, was extremely interested in the fate of the U-boat.

These considerations present a further possible speculation that “Bubbi” was in fact Bormann himself, who would have certainly had access to the bunker’s outside radio communications. Indeed, Bormann not only had access, but *controlled* those communications. Thus the “Bubbi message” to Hirschfeld for a “healthy return” was in all probability a coded message for the U-boat to return to Germany to pick up some new passengers.

The movements of the U-234 after it received Dönitz’s message reasserting the Admiral’s direct control over it, and his orders to depart as soon as it was able, give credence to this scenario, for Fehler received the radio message on April 14th, and the submarine did not depart Norway until April 16th, the very same day as Russian artillery came within range of Berlin and began the bombardment of

the city.⁸¹ Hydrick maintains the possibility that the news of the Russian bombardment itself was a prearranged signal for the U-boat to set sail and await further orders.⁸²

We have already noted Hydrick's scenario that Bormann and Müller escaped on the flight of Hanna Reitsch and General Von Greim from Berlin on April 29 (if one follows the early date) or April 30 (if one follows the later date). This would have allowed Bormann and the Gestapo chief a one to two day head start from others remaining behind with Hitler in the bunker, and waiting for the moment that they too could make their escape. More importantly, as Hydrick states, it would allow time to leave suitable false trails and concoct alibis "that would resolve their fates for the outside world and eliminate post-war investigations."⁸³ Having placed suitable body doubles at the prearranged spots for their "deaths" and rehearsing the eyewitnesses – Nazis all - in their confusing and contradictory stories, Bormann and Müller flew northward to safety.⁸⁴

Once in Hamburg, what happened? Hydrick summarizes the remaining parts of his scenario this way:

If the above is true, the most probable scenario is that upon disembarking Hamburg, the U-boat took Bormann, under protection of the watchful eyes of the Allies – remember the planes that did not attack – through the English Channel to a prearranged rendezvous point in the Bay of Biscay. There he boarded another vessel and was ferried to the north coast of Spain, where OSS reports say he stayed with one "Leon DeGrelle." In Spain, Bormann quietly completed his European business affairs behind the scenes and under the protection of Spain and, by secret extension, the United States' watchful eyes, as he consolidated the underground economy that would soon reinvent Europe.⁸⁵

But there is no need for Hydrick to have invoked the complicit participation of the U.S.A. in this scheme. Bormann could have negotiated the surrender of the U-234 – its precious enriched uranium-235 and infrared proximity fuses – to the United States *without* disclosing his and Müller's intended presence on the U-boat,

and thus, cloaking themselves behind a wall of protection that they knew would be extended to the U-boat – witness the Allied “air attacks” that never occurred once again – have escaped via the U-234 wholly unbeknownst to the Americans themselves. As will be seen from the evidence presented in part three, this scenario does have a certain degree of evidence in its favor.

There is other circumstantial evidence to suggest Müller and Bormann escaped.

For example, Hydrick mentions the case when Heinrich Müller’s alleged grave in Berlin – conscientiously decorated by family members for years after his death – was ordered exhumed by the district attorney for West Berlin. What was found were the remains of *three* different men, none of whom was Müller.⁸⁶ As for the dental and other forensic evidence, one Bormann expert confided to Paul Manning that “Bormann planned this flight with extreme care and part of the grand design was a scheme to lead future forensic and dental specialists astray.”⁸⁷

But the most important evidence are the radio messages that Bormann sent to Dönitz during the period from April 30th to May 1st. According to the official standard history, Adolf and Eva Hitler committed suicide around 3:30 pm on April 30, about twelve hours after Reitsch’s and Von Greim’s flight out of Berlin. At approximately 5:30 the same afternoon, Bormann radioed the Admiral that he had been chosen as Hitler’s successor, but he did *not* inform Dönitz that Hitler was dead. Dönitz, who was not about to be tricked into treasonous acts as had been Göring and Himmler – again at Bormann’s trickery – insisted that Bormann supply witnesses to this effect, which Bormann did not do.

As Hydrick observes, every tactic of interpreting this exchange along the standard lines of his presence in the bunker, and eventual death while trying to flee on foot, fail. They were totally meaningless exchanges on this view. But they *do* make sense if Bormann was already on the flight with Von Greim, Reitsch, and Müller, and simply no longer present in Berlin at all. Hence, Bormann did not know of Hitler’s suicide, nor could he provide witnesses.⁸⁸

There was also a legal reason for keeping knowledge of the Führer’s suicide from the Admiral, for “once Doenitz knew Hitler was

dead, the Admiral's command would be law and Bormann would be one of the first of Hitler's paladins he would seek to bring down, and Bormann knew it."⁸⁹ Hence, Bormann most likely sent his last message to Doenitz on May 1. This is the message known to most historians where Bormann informed the Admiral that Hitler's last will and testament's political provisions were in force, though, once again, he carefully avoided mentioning that Hitler was dead. Bormann most likely sent the message from Hamburg, leaving the Admiral to assume he was still in Berlin.⁹⁰

There is more circumstantial evidence to support the conclusion that Bormann was no longer in Berlin from April 30th onward. For example, the official version of history maintains that Josef Göbbels forced Bormann to sign the document that notified Admiral Dönitz of Hitler's demise. But a photograph of the actual document shows only Göbbels' signature; Bormann's is completely absent. More importantly, all communications up to April 30th between the bunker and the Admiral had gone through Bormann, since he controlled both the bunker's telephone exchange as well as its radio communications center. But on April 30th, Göbbels takes command of them, "an event," notes Hydrick, "not likely to have been allowed by Bormann had he still been there. Apparently, judging from the evidence, the Reichsleiter seems to have left the premises."⁹¹

Finally, as if all of this were not enough, British Field Marshall Sir Bernard Law Montgomery was said to have maintained that British intelligence received a report of Bormann in Hamburg during the night of May 1, 1945.

It's beginning to look like, for once, Stalin was telling the truth.

(b) The Movements of the U-234

There are, however, still details of the scenario that remain to be filled in. As noted in the previous section, the massive U-234 and its precious uranium cargo left Norway on April 16th, 1945, probably on the prearranged signal of the beginning of the Russian artillery bombardment of Berlin. Bormann, in turn, if one accepts Hydrick's scenario, as this author most decidedly does, did not arrive in

Hamburg until sometime on April 30th or May 1st. Thence he and Müller departed on the U-234, using the cover they knew the Americans would accord to its cargo to effect their own escapes.

But what was the U-234 doing during this time, and equally importantly, what did it do after leaving Germany with its new passengers? Hydrick summarizes this mysterious period in no uncertain terms:

There are more mysteries about U-234 than its enigmatic passengers and cargo. The whereabouts of U-234 from 16 April until 12 May 1945, almost a month, is a mystery hidden by a series of riddles, to the point of almost being a conundrum – an unsolvable puzzle. Review of the U-boat's logbook itself reveals a perplexing collection of contradictions when compared against intercepted radio transmissions, other accounts of the voyage, and even other information within the same logbook, suggesting that at least part of its record is falsified. In fact, even a cursory glance at what are purported to be various pages of the war log reveals astounding inconsistencies in the physical nature of the book and the handwriting therein, leading to questions and doubt regarding its very provenance. In addition, the few apparently clear facts provided by the war log reveal a bizarre and unexpected travel routine for a fleeing U-boat. And the actions taken by the U-boat commander in the final days prior to its surrender are duplicitous and deceitful – and apparently in coordination with United States Navy activities.

In short, the evidence suggests that U-234 may not have left Norway under the conditions reported, may not have cruised the course across the Atlantic it was claimed to have traveled, and definitely did not surrender when, where, and to whom it was ordered to capitulate. Instead, in almost every case, its commander, Captain Lieutenant Johann Heinrich Fehler, appears to have been intent on achieving a different, unknown end.⁹²

As already indicated, the “Bubbi” message was perhaps code for the U-234 to return to Germany, a possibility Hydrick himself

entertains.⁹³

As also noted, after the famous “Bubbi” message, the U-234 received a message from Grand Admiral Dönitz himself ordering the ship’s captain, Fehler, to sea as soon as preparations were complete. As a result, notes Hydrick, Fehler was put in the unenviable position of having to answer to two separate chains of command, to disobey either of which would seriously jeopardize not only his career but perhaps his very life itself.⁹⁴ Fehler’s solution to this dilemma was rather ingenious, for he contrived to fulfill both sets of orders, for as Top Secret Allied Ultra intercepts indicate, the U-boat seems to have left port *twice*, once on April 16th, in fulfillment of the prearranged signal from Berlin, and once on April 18th, in fulfillment of Dönitz’s orders.⁹⁵

As if to compound this contradictory state of affairs, the U-boat’s own logs put it some 200 miles further *north* than the April 16th intercept, which stated it was sailing on a *southern* course. In fact, the U-boat’s logs show it to be *much* further north in the environs of Bergen, Norway!⁹⁶ And complicating matters even further, the war log ends on April 18th, and is replaced by another “official” log!

A clue to resolution of the discrepancy is given in Hirschfeld’s memoirs, where he records that the commander of U-boats for the northern region, Captain Hans Rosing, sailed out to the U-boat and boarded it from a launch, a hazardous undertaking to say the least, given Allied air supremacy over the North Sea! But Hydrick notes that Rosing was headquartered in Bergen, not Kristiansand much further south, from which the U-234 departed. Hydrick reaches the obvious conclusion: the U-234 had been diverted northward for some very secret purpose, which was directly and personally communicated to the U-boat’s officers by the northern commander of U-boat forces personally. Hence, the “official” log book replaces the normal war log book from that point onward.⁹⁷ This special contact may in fact have been to bring to the U-boat directly more top secret communications directly from the *Führerbunker* or perhaps to install special high frequency radio equipment to allow the ship to continue receiving communications from Hitler’s headquarters while at sea.⁹⁸

But what of the strange discrepancy between the two logbooks?

Why does one logbook end abruptly and its supposed sequel not jive with the rest of the evidence regarding U-234's movements? When I first requested a copy of the captured war log of U-234 from United States archives at the beginning of my research, I was told by an archivist that the logbook had been thrown into the sea by U-234's captain. He asserted that Fehler got rid of the journal prior to the U-boat's surrender to avoid compromising the document and the boat's movements.

But U-234 carried Nazi Germany's greatest secret weapons, I reasoned, including the V-4 rocket, the Messerschmidt (sic) 262 jet fighter, all of the plans and documents required to manufacture them, atomic bomb components *and presumably plans to build those weapons*, as well. If Fehler did not know the important details about his freight, which seems improbable despite his later claims, he at least knew the basic reason for and deep importance of his cargo, passengers and mission, and yet he surrendered them all intact. I reasoned that this was a significant incongruity. Had Captain Fehler surrendered the valuable Nazi secrets and personnel, supposedly with little more than a second thought, but had refused to surrender his comparatively trivial logbook? The journal, presumably, simply reported the course he cruised prior to surrender. What could be damning about that if the story was as simple as suggested? No, the logbook itself apparently held important secrets that Fehler did not want revealed, and thus Fehler had indeed consigned it to the deep and we would never know U-234's whereabouts between 16 April and 12 May 1945. Or, possibly, the book was intact but held damning evidence, and thus was being kept in some separate archive, out of circulation from prying eyes.⁹⁹

Uncovering a microfilm version of the logbook, Hydrick then discovered that there are indeed *no entries from April 18th – the date of the U-234's "second" departure from Kristiansand – and May 12th, 1945, when the U-234 first transmitted its intention to surrender to the Allies.*¹⁰⁰

Undaunted, Hydrick then inquired where the original copy of this microfilmed logbook was, and was informed that it had been returned to Germany to become part of the German *Bundesarchiv* or Federal archives. Needless to say, he ordered copies of the logbook from April 19, 1945, to May 12, 1945.

This new logbook quickly revealed problems of its own, for its stated courses, speeds and coordinates varied significantly from Allied radio direction finding coordinates, and more importantly, its handwriting, in the opinion of one US Navy expert consulted by Hydrick, was much too neat to have been made under normal operational conditions, a fact suggesting that the whole logbook was a carefully doctored copy of an original.¹⁰¹ All the evidence forced Hydrick to conclude that there was “an organized effort to camouflage U-234’s movements.”¹⁰² The only questions were who doctored the records, and why?

But this new log contained yet another astounding fact: during most of the period from April 18 to May 12, it was barely moving, maintaining a mere one to two and a half miles per hour, barely enough speed to maintain the craft’s steerage.¹⁰³ To put it succinctly, while the standard history of the U-boat would have it that the craft was racing toward Japan at its surface speed of 20 knots, “the slow speed recorded in the log seems to suggest that Fehler was marking time in an unexplained effort to remain close to home.”¹⁰⁴ And according to the same logbook, during the crucial period from April 30, 1945, to late May 5, 1945, the same time frame from Bormann’s disappearance from Berlin to Dönitz’s signal to the Allies of his intention to capitulate on May 5, 1945, the U-boat ran submerged continuously for six days.¹⁰⁵ The purpose of these submerged meanderings were, for Hydrick, quite clear: the U-boat was actually making a very secret “side trip,” one that, perhaps, its new passengers, Bormann and Müller, wished to conceal after the fact from prying American eyes.¹⁰⁶

Then, through a series of carefully chronicled deceitful communications and maneuvers,¹⁰⁷ Captain Fehler avoided Canadian orders to surrender to Canadian and British authorities at Halifax, Nova Scotia, and instead piloted his boat to a safe

rendezvous with the US destroyer *Sutton*, which had under aid of radio jamming from America designed to cut off British and Canadian communication with the submarine, signaled the U-boat by semaphore to proceed to the Gulf of Maine and “*to ignore all further communications from Halifax.*”¹⁰⁸ Meanwhile, the U-boat’s radio operator Hirschfeld recorded in his memoirs that he observed Dr. Heinz Schlicke, the inventor of the crucial infrared proximity fuses, throwing canisters of microfilm into the ocean from the submarine’s conning tower, stating “*There goes the rocket that could fly the Atlantic,*”¹⁰⁹ a statement that, if true, corroborates my argument in *The SS Brotherhood of the Bell* that the Nazis may not only have successfully exploded an atom bomb prior to the end of the war, but successfully test fired an actual intercontinental ballistic missile designed to carry it to targets in the United States. Bormann’s “deal” with the Americans had now revealed its teeth.

Weighing all the evidence – and we have summarized only very briefly Hydrick’s intricate and meticulously researched scenario – he comes to his final conclusion that the U-234 was indeed

“the large U-boat” reported by Soviet intelligence that had the secret mission of rescuing Martin Bormann from Germany, delivering him safely to Spain, and delivering the cargo to the United States in exchange for Bormann’s freedom.¹¹⁰

While agreed with Hydrick on the probable likelihood that the U-234 indeed transported Bormann and Müller to the safety of Nationalist Spain, and while acknowledging that it was probably part of an extremely secret deal between the Nazi *Reichsleiter* and high level American intelligence authorities – recall again Dulles’ comment to researcher Paul Manning, and ask yourself how Dulles would have known Manning was “on the right track” – it is also true, as we shall see in subsequent chapters, that the activities of Bormann’s Nazi International would hardly have been pleasing or acceptable to Bormann’s erstwhile American allies. It was, for both, but a marriage of convenience, and a very temporary one at that.

But given very real possibility that Bormann did *not* offer himself or Müller as part of the original agreement, but only offered the

Americans the enriched uranium and infrared proximity fuses, and thus used U-234 as a shield to cover his and his Gestapo colleague's escape under what he knew would be tacit high level American efforts designed to ensure the U-boat's safe passage, what leverage might he have held onto to coerce or ensure American cooperation in the future? That is a question for future chapters.

However, there is a much *larger* context from which to view the escapes of Bormann and Müller and the surrender of the U-234's atom bomb components than even Hydrick himself surmised, and that is the context of the Nazi Bell device, and the probable escape of the man who ultimately controlled it – SS General Hans Kammler – and again, the key player in this regard is Martin Bormann.

But first, there is some interesting corroboration of Hydrick's scenario that has recently come to light in the recollection of a former Spanish spy for the Nazis.

4. *The Velasco Scenario*

A review of the outlines of Bormann's escape, according to all the massive amount of material unearthed by Carter Hydrick, is in order, so that we may appreciate the story of Velasco. In Hydrick's scenario, we have the following elements:

- 1) Bormann negotiated the surrender of Nazi Germany's atom bomb components, including enriched uranium-235, and quite possibly actual plans for an atom bomb, to the United States in return for his and Heinrich Müller's safe passage aboard the U-234 to the Bay of Biscay;
- 2) Once in Spanish waters, Bormann and Müller were covertly transferred by boat or motor launch to Spanish shores, where they remained while Bormann finished business in Europe;
- 3) Bormann and Müller most likely boarded the U-234 sometime between April 30 and May 1st or 2nd, during the period that the U-boat was apparently marking time submerged somewhere in the waters of the North Sea; once transferred, the U-boat made its way through the English channel to Spanish waters,

accomplished the transfer, and then proceeded to surrender to U.S. authorities as per the previously negotiated arrangement;

- 4) As components of their carefully orchestrated escape from Berlin, Bormann and Müller used carefully placed (and expendable) body doubles designed to create several trails for the Allies to follow, each of which ended in a “dead” Bormann or Müller; and,
- 5) Body doubles were also used after the war to create a spate of “Bormann sightings” throughout Europe to obscure his real location and movements.

Implicit in this whole scenario is the possibility that Bormann also drove a hard bargain with his American counterparts, namely, that the U.S. would make only token efforts to roll up his camouflage and dummy corporations, and keeps its hands off any projects he did not wish to fall into Allied hands.

It was a policy Bormann could well afford to insist upon, for most likely knowing as well of the secret agreement between Dulles and General Reinhard Gehlen, as well as of America’s mad scramble to recover and recruit Nazi scientists for America’s space program, Bormann knew he would have the on-the-ground personnel to “enforce” his demands if the situation required it. It was, in short, the time-tested Bormann method: blackmail, with teeth. America, wishing a quick end to the war and to avoid the bloodshed that an invasion of the Japanese home islands would cost, cut the bargain, and dropped the uranium bomb made possible by Bormann’s uranium and the plutonium bomb made possible by Bormann’s infrared proximity fuses (and possibly Bormann’s atom bomb plans as well).

With this scenario in mind, it is time to summarize the story of Spanish Nazi spy and sympathizer Don Angel Alcazar de Velasco.

In an account published by Sharkhunters only after Velasco’s death, entitled *Escape from the Bunker*, Velasco recounts his alleged last days in Berlin serving as a Spanish liaison in the Bunker, once again in service of Bormann’s strategic evacuation plan. Velasco minces

no words about his own opinion of Bormann's postwar Nazi International:

(The Nazis) considered me one of their most trusted agents with access to their closely guarded plans for re-emergence as a world power.

I know the power of these men and their underground organization. I have seen the determination with which they plotted their return to power, and have helped with the formation of secret action groups in two continents. They are well organized. The High Command still exists and meets each year in western Germany, where they do not lack support.¹¹¹

In this capacity, Velasco was summoned to the Bunker where, according to his allegations, he remained up through the final events.

There Velasco observed the quickly deteriorating mental and physical health of Hitler, even describing symptoms that resemble Parkinson's disease.¹¹² Allegedly observing the relationship of Hitler and Bormann firsthand, Velasco noted that "Hitler could hardly have turned around in those days without finding the attentive Bormann at his elbow. And such ready attention was to pay off for Martin Bormann. Before the end, he was to take charge, even over his old master."¹¹³ But the most serious allegation concerns Hitler's and Eva Braun-Hitler's escape, for shortly after hearing some official radio proclamation concerning the Führer, Velasco claims he saw the door of Hitler's private quarters open. Eva Braun appeared, a fur coat folded over her arm and carrying a vanity case in her right hand. She was, according to Velasco, escorted from the Bunker by an SS colonel. Shortly after this, Velasco states that he observed Hitler appear in the company of Field Marshal Wilhelm Keitel and Colonel-General Alfred Jodl... *and* Grand Admiral Karl Dönitz! These events, according to Velasco, transpired on April 21, the day after Hitler's birthday.¹¹⁴

It was this odd detail that first convinced Sharkhunters president and founder, Harry Cooper, to dismiss Velasco's whole story – recounted to him in a personal letter from Velasco – as a wild fabrication. Cooper, however, also contacted the head of Dönitz's

personal guard to ask him if the Admiral was ever in Berlin during March or April of 1945. Much to his surprise, the individual responded that according to his notes from the period, the Grand Admiral was indeed in Berlin on the very date Velasco had specified.¹¹⁵

In any case, Velasco went on to outline a scenario of Hitler's escape – not Eva Braun's – that included the use of a carefully replaced Hitler double in the bunker from April 21st to April 30th, an arrangement made by Bormann.¹¹⁶ We shall say more about Velasco's scenario of Hitler's escape in the next chapter, but suffice it for the moment to observe that the method of operation here is exactly that used in his own and Müller's escape: doubles.

What interests us here is Velasco's account of Bormann's own escape, which he maintains was to Spain, via a U-boat, and thence from Spain to Argentina, with Velasco in tow, in 1946 on a "black U-boat" still conducting covert operations under orders from Nazis long after the war had ended.¹¹⁷ As we shall see in a subsequent chapter, the idea of German U-boats conducting independent operations under a still functional Nazi chain of command long after the war had ended is not as far-fetched as it might at first glance seem.

5. A Reconciliation and Reconstruction

In any case, Velasco's story, with its oddly corroborated mention of Dönitz's presence in the bunker on April 21, 1945, also broadly corroborates Hydrick's meticulous reconstruction of Bormann's and Müller's probable movements from April 30, 1945 to their arrival in Nationalist Spain prior to May 12, 1945 on the U-234. Where Velasco differs in his account is how Bormann made it to Argentina, for as we shall see in a subsequent chapter, Argentine intelligence documents date his arrival in that country to 1948, not to 1946, as Velasco maintains, and moreover, they have Bormann arriving on a freighter from Genoa, Italy, disguised as a Jesuit priest, and not on a U-boat.

Even these discrepancies might be reconciled, however, if one recalls the supposition advanced here that Bormann used many doubles to sew the confusion of a spate of postwar "Bormann

sightings” throughout Europe. It is entirely possible that one such double was either on the U-boat with Velasco, or on the freighter from Genoa, or both.

B. The Escape of SS Obergruppenführer Hans Kammler

As implied earlier, there is a wider context than even the machinations surrounding the Nazi surrender of crucial atom bomb components to the Americans on the U-234, and that context is the escape of SS General Hans Kammler and of the Nazis’ most highly classified secret weapons project, the Bell. As I detail in my book *Reich of the Black Sun*, Kammler’s probable escape from Europe follows a by-now familiar pattern, for the stories of his death come in no less than four mutually conflicting versions, a pattern we have already seen repeated with the escape of Bormann and Müller.¹¹⁸

1. Agoston: The Priest Disguise and a Bormann Parallel

But as I also recount in that book, Kammler himself confided, at one point, that he intended to escape to a Roman Catholic monastery, where, disguised as a monk and priest, he would eventually flee Europe.¹¹⁹ This story was disclosed by none other than Dr. Wehrner Von Braun! Again, the parallel to Argentine intelligence documents recording Bormann’s own escape from Europe disguised as a Jesuit priest goes without mention. And obviously, in both cases, a Vatican connection is implied. But in Kammler’s case there is something more, and that is that he knew beforehand of this possibility of escape.

2. Nick Cook and the Luftwaffe’s Kampfgeschwader 200: The Escape of Kammler and the Bell Courtesy of Martin Bormann

But there is another possible escape route for Kammler, one first mentioned by Polish Bell researcher Igor Witkowski, and corroborated by fresh research of British journalist Nick Cook in his book *The Hunt for Zero Point*. Noting that Martin Bormann had *personally* turned over to General Kammler the Luftwaffe’s *Kampfgeschwader 200*, the unit that operated all of Nazi Germany’s

long-range heavy lift four engine Junkers 290 and is sole remaining six-engine Junkers 390, Witkowski and Cook speculate that the enormous aircraft, last photographed in Prague in April, 1945, as it was being loaded with cargo,¹²⁰ *the same time frame as the events recounted in Bormann and Müller's escape in Hydrick's scenario*, made its way from there, with possibly the Bell itself, its project documentation (which would have been kept by Kammler at the headquarters of his secret weapons think tank in Pilsen, Czechoslovakia, near Prague) and the general himself. From Prague it flew the general and the Bell first to Bodo airbase in Norway, and thence to disappear into the postwar black projects of the United States.

But as I mentioned in *The SS Brotherhood of the Bell*, British author Geoffrey Brooks maintained that the flight ended, not in America, but in Argentina.¹²¹ As Brooks maintains in his own book *Hitler's Terror Weapons: From V-1 to Vimana*, the Bell was deliberately *withheld* by Bormann from the Allies.

To put it succinctly, *Bormann surrendered the atom bomb components aboard the U-234 to the Americans, while simultaneously giving Kammler direct control of the last remaining Junkers 390 in order to spirit the far more valuable Bell device and its documentation to Argentina, where it would remain in Nazi hands.* The Junkers 390 was fully capable of making the non-stop flight from Germany to Argentina without the necessity of stopping for fuel.

But is that what in fact happened?

As already mentioned, Witkowski and Cook site evidence that the 390 flew to *Norway*, and thence conjecture that it flew from there on to America. Can a flight to Norway be reconciled with a flight to Argentina?

Indeed it can, and indeed, it may have been altogether *necessary* to take such a circuitous route, for a *direct* flight from Czechoslovakia, where the last known picture of the Junkers 390 was taken, to Argentina, would have flown over airspace directly controlled by the Allies, whether it flew over France, Italy, or the Balkans makes no difference. Once over the bulge of Africa the way would have been clear for the relatively short hop over the Atlantic to the coast of Brazil, and then down the coast to Argentina. But it was

negotiating that first leg of the journey over hostile airspace that would have been the most dangerous for an easily spotted massive aircraft like the Junkers 390.

So why Norway?

Given the importance of the Bell in the hierarchy of Nazi secret weapons, and the self-evident desire of Bormann to maintain independent Nazi control of the project and the physics it represented, not to mention his probable desire to protect its ultimate project head, General Kammler and the detailed knowledge of the project that he doubtless had, the flight to Norway makes sense, for the Junkers 390 could easily fly out over the relatively quieter airspace of the North Atlantic to Nazi-friendly Nationalist Spain in a gigantic loop. Once in Spain it could refuel, and, if need be, take on additional cargo or passengers for the final leg of the flight to Argentina. In the light of evidence presented later in this book that some aspect of the Bell project continued to be researched in Argentina by Nazi scientists, this is now my preferred and favored view of what happened to the Bell, General Kammler, and the last flight of the Junkers 390.

D. Conclusions: A Possible Scenario

Summarizing all that has gone before, we are now in a position to outline the larger scenario of the “escape of the Unholy Trinity,” Bormann, Müller, and Kammler, the three men who, as the quotation that began this chapter avers, represented the necessary expertise to the continuation of any independently controlled Nazi secret weapons project, for each of the three men represented expertise in handling and camouflaging large amounts of money (Bormann), the security necessary to protect the organization and its projects (Müller), and the administrative requirements of handling an advanced research project like the Bell (Kammler).

Bormann and Müller arranged for body doubles to be planted and an escape-and-death scenario cultivated for postwar Allied and Soviet investigators, while arranging their flight from Berlin by air, and thence to Hamburg where the two boarded the U-234 which Bormann knew, by dint of a secret arrangement negotiated directly

with the Americans – very likely through OSS station chief in Zurich, Allen Dulles – that the U-234 would receive quiet and covert protection from them in order to secure the safe arrival of its nuclear cargo in the United States. This implies further that Bormann at least, and Müller and Kammler most likely, were accurately apprised on the actual state of affairs in the Manhattan Project, and knew of its crucial shortages of fissile uranium-235 as well as of its difficulties in making a plutonium bomb workable without the infusion that the U-234's infrared proximity fuses could provide.¹²²

Requiring a project that would not require the large facilities needed by rocket programs or atom bombs, and one that promised to pay far larger dividends in any case, Bormann surrendered the atom bomb components, while seeing to it that the Bell safely escaped. Kammler and the Bell flew to Argentina, where they would become the nucleus of an ongoing independent Nazi project, as we shall see later. Bormann and Müller joined him there subsequently.

But before we can examine that case, we need first to examine another possible, and highly significant, escape, as well as examining the “rodents at the other end of the ratlines,” and the postwar *political* activities of Bormann's Nazi International, in order to put it all in perspective. By now, however, it is abundantly clear that the broad outlines of Wilhelm Landig's science fiction novels are anything but fiction.

¹ William Stevenson, *The Bormann Brotherhood* (Harcourt Brace Jovanovich, 1973), p. 164.

² Q.v. Igor Witkowski, *The Truth About the Wunderwaffe*, pp. 255-256, and my *SS Brotherhood of the Bell*, pp. 157-159.

³ Henry Stevens, *Hitler's Suppressed and Still-Secret Weapons*, p. 1.

⁴ For an outline of the first, second, and third generation nuclear weapons and its relevance to the Nazi atom bomb and Bell projects, see my *SS Brotherhood of the Bell*, pp. 283-287.

⁵ Henry Stevens, *Hitler's Suppressed and Still-Secret Weapons*, pp. 4-5.

⁶ For the story of Bormann placing Kammler in charge of the special “evacuation command” and placing him in charge of

Kampfgeschwader 200, and the disappearance of the Bell, see Nick Cook's *The Hunt for Zero Point*, pp. 182 ff.

⁷ Joseph P. Farrell, *Secrets of the Unified Field: The Philadelphia Experiment, The Nazi Bell, and the Discarded Theory* (Adventures Unlimited Press: 2008), pp. 230-232.

⁸ Paul Manning, *Martin Bormann: Nazi in Exile* (Lyle Stuart, 1981), pp. 205-206.

⁹ Ibid.

¹⁰ Ibid., pp. 207-208.

¹¹ Manning, *Martin Bormann: Nazi in Exile*, p. 20.

¹² Manning, *Martin Bormann: Nazi in Exile*, pp. 13-14.

¹³ This case is made in my previous book, *Reich of the Black Sun*, pp. 3-158. Chapter two of that work synthesizes Hydrick's own research on the state of German isotope enrichment, while the overall thrust of my previous book is to argue that the Nazis may actually have successfully exploded at least one and possibly two nuclear devices, beginning in October, 1944, fully eight months prior to the Manhattan Project's own success.

¹⁴ Mr. Brooks, as readers of my *SS Brotherhood of the Bell* will recall, is the author of *Hitler's Terror Weapons: From V-1 to V2*. He is also the co author with Wolfgang Hirschfeld of the book *Hirschfeld – The Story of a U-Boat NCO 1935-1945*. He "is a professional translator of German military works" and currently lives in Argentina. (From "Report on Three Incidents Suggestive of Invisibility of German Submarines to Visual and Electronic Detection between 27 March and 4 July 1945," Personal communication to the author, July 4, 2008, 6:54 am., p. 1.)

¹⁵ Farrell, *Reich of the Black Sun*, pp. 60-62.

¹⁶ Brooks, "Report on Three Incidents Suggestive of Invisibility of German Submarines to Visual and Electronic Detection between 27 March and 4 July 1945," Personal communication to the author, July 4, 2008, 6:54 am., p. 1.

¹⁷ Ibid., pp. 1-2.

¹⁸ Farrell, *Reich of the Black Sun*, pp. 60-62ff.

¹⁹ Brooks, "Report on Three Incidents Suggestive of Invisibility of German Submarines to Visual and Electronic Detection between 27 March and 4 July 1945," Personal communication to the author, July 4, 2008, 6:54 am., p. 2. Brooks cites Wolfgang Hirschfeld, *Feidnfahrten*, (Vienna: Neff Verlag, 1983) and the English version, Geoffrey Brooks, *Hirschfeld* (Pen and Sword Books, 1997), pp. 192-202.

²⁰ Ibid.

²¹ See my *SS Brotherhood of the Bell*, pp. 225-236

²² See my *SS Brotherhood of the Bell*, pp. 144-148. The name suggests a connection to a Bell-related project somewhere in the environs of the Rhine River, a project some have alleged to have existed, but for which the present author has yet to find adequate documentation. In any case, the German Navy's interest in a project like the Bell would have been profound, and the connection is therefore logical.

²³ See my *Secrets of the Unified Field*, pp. 102-190.

²⁴ Brooks, "Report on Three Incidents Suggestive of Invisibility of German Submarines to Visual and Electronic Detection between 27 March and 4 July 1945," Part II, Personal communication to the author, July 6, 2008, 8:43 am., p. 1.

²⁵ The official, "standard" version.

²⁶ Yet another "official" standard version.

²⁷ Carter Plymton Hydrick, *Critical Mass: How Nazi Germany Surrendered Enriched Uranium for the United States' Atomic Bomb*, pp. 195-196.

²⁸ Hydrick, *Critical Mass*, p. 196.

²⁹ Ibid.

³⁰ Ibid., pp. 196-197, emphasis added.

³¹ Hydrick, *Critical Mass*, p. 197.

³² Ibid., p. 198.

³³ Ibid.

³⁴ Hydrick, *Critical Mass*, p. 199.

³⁵ Ibid.

³⁶ Ibid.

37 Ibid.

38 Hydrick, *Critical Mass*, pp. 198-199.

39 Ibid., p. 199.

40 Ibid., p. 201.

41 Hydrick, *Critical Mass*, p. 201, emphasis added.

42 Ibid., p. 202.

43 Ibid., p. 203.

44 Ibid.

45 Ibid., p. 204.

46 Hydrick, *Critical Mass*, p. 205.

47 Ibid.

48 Ibid.

49 Ibid

50 After all, for an absolutely 100% surefire DNA test, one would have to have a sample of Bormann's DNA itself to begin with! Hydrick, *Critical Mass*, p. 205.

51 Hydrick, *Critical Mass*, p. 206.

52 Ibid.

53 Ibid.

54 Hydrick, *Critical Mass*, pp. 206-207.

55 Ibid., p. 207.

56 Ibid.

57 Ibid., p. 208

58 Hydrick, *Critical Mass*, p. 208.

59 Ibid., p. 209.

60 The presence of four people in the Fieseler would also account for the fact that Reitsch recalls that the overloaded little aircraft barely was able to clear the Brandenburg Gate at the end of the runway during their escape flight from Berlin.

61 Hydrick, *Critical Mass*, pp. 210-211.

62 Ibid.,

63 Ibid., p. 212.

64 Ibid.

⁶⁵ Hydrick, *Critical Mass*, p. 146.

⁶⁶ Ibid.

⁶⁷ Ibid., p. 149.

⁶⁸ Ibid. Hydrick's account of the encounter is substantially the same as Brooks'. Cf. p. 150.

⁶⁹ Ibid., p. 150, emphasis added.

⁷⁰ Hydrick, *Critical Mass*, p. 150.

⁷¹ Ibid., p. 151.

⁷² Ibid., p. 152.

⁷³ Ibid.

⁷⁴ Hydrick, *Critical Mass*, p. 153.

⁷⁵ Ibid., p. 154.

⁷⁶ Ibid.

⁷⁷ Ibid., pp. 154-155.

⁷⁸ Hydrick, *Critical Mass*, p. 155.

⁷⁹ Ibid.

⁸⁰ Ibid. As was seen from chapter one, this is a slight inaccuracy on Hydrick's part, since Hitler had once again separated the offices of Reichs Chancellor and Reichs President, giving the latter and more powerful office to Dönitz as well as specifically appointing Dönitz Head of State. But the effect of Bormann's communication to Dönitz was the same.

⁸¹ Hydrick, *Critical Mass*, p. 215.

⁸² Ibid.

⁸³ Ibid., p. 217.

⁸⁴ Ibid, p.,. 218.

⁸⁵ Hydrick, *Critical Mass*, pp. 218-219.

⁸⁶ Ibid., p. 221.

⁸⁷ Ibid.

⁸⁸ Hydrick, *Critical Mass*, p. 226.

⁸⁹ Ibid., p. 227.

⁹⁰ Ibid.

⁹¹ Hydrick, *Critical Mass*, pp. 228-229.

⁹² Hydrick, *Critical Mass*, pp., 233-234. Hydrick's research here, as throughout most of his book, simply cannot be bested, and, while every attempt is made to summarize it accurately and completely here, no such attempt can replace reading the full contents of his book. Hydrick's research is based, in turn, on Hirschfeld's critical German memoirs, and Geoffrey Brooks' equally vital English translation: *Hirschfeld, The Story of a U-Boat NCI – 1940-1946*.

⁹³ Ibid., p. 237.

⁹⁴ Ibid.

⁹⁵ Hydrick, *Critical Mass*, pp.237-238.

⁹⁶ Ibid., p. 238.

⁹⁷ Ibid., pp. 238-240.

⁹⁸ Ibid., pp. 240-241.

⁹⁹ Hydrick, *Critical Mass*, pp. 241-242, emphasis added.

¹⁰⁰ Ibid., p. 242.

¹⁰¹ Hydrick, *Critical Mass*, p. 244.

¹⁰² Ibid., p. 245.

¹⁰³ Ibid.

¹⁰⁴ Ibid., p. 246.

¹⁰⁵ Ibid. p. 247.

¹⁰⁶ Ibid., pp. 251-253.

¹⁰⁷ Ibid., pp. 255-266.

¹⁰⁸ Hydrick, *Critical Mass*, p. 267, emphasis Hydrick's.

¹⁰⁹ Ibid., emphasis mine.

¹¹⁰ Ibid., p. 271.

¹¹¹ Don Angel Alcazar de Velasco, *Escape from The Bunker*, ed. Harry Cooper, (Poison Pen Publishing, 2004), p. 2.

¹¹² Ibid., p. 12.

¹¹³ Ibid., p. 15.

¹¹⁴ Velasco, *Escape from the Bunker*, pp. 21-22.

¹¹⁵ Ibid., p. 22, note of the editor.

¹¹⁶ Ibid., p. 24.

¹¹⁷ Ibid., pp. 30-39.

¹¹⁸ See my *Reich of the Black Sun*, pp. 107-110.

¹¹⁹ Ibid., p. 109.

¹²⁰ See my *The SS Brotherhood of the Bell*, p. 168.

¹²¹ Ibid., pp. 170-171.

¹²² See my *Reich of the Black Sun*, pp. 3-152.

Hotels and Haciendas for Hitler: Confronting the Führer's Suicide Story

““Why would Hitler, who was anxious for everyone else to leave Berlin, want someone to come to him? Why would he have been so keen to talk to the head of an almost non-existent entity? The official story fails to justify Greim and Reitsche’s extremely dangerous flight. It also does not explain why the pair’s flight from the Luftwaffe airbase at Rechlin near Berlin to Gatow airport on Berlin’s periphery was accompanied by an escort of 30-40 fighter jets - in other words, the extant Luftwaffe virtually in its entirety. Clearly the flight had a more serious purpose than we have been led to believe.”

Giordan Smith¹

A. The 1964 Police Gazette Article

In 1964, the *Police Gazette* ran an article about the postwar survival of the Führer himself, Adolf Hitler. Authored by Harvey Wilson, the article stated in no uncertain terms that

For the first time, an outsider has seen Adolf Hitler's super-secret hideout in the wilds of Argentina.

His eyewitness account of the impenetrable Nazi stronghold, confirms the startling facts first unearthed and published by the *Police Gazette* twelve years ago.

Traveling through the mountainous region of [blacked out] province - a sprawling wilderness of lakes, waterfalls, gigantic glacier caves and forested islands - Jack Comben, correspondent of the *London Daily Express*, discovered the last secret outpost of Hitler's Germany, 100 miles north of [blacked out].

It was in 1952 that the *Police Gazette*, after having obtained top secret Allied Intelligence reports and information based on interviews with former members of the Wehrmacht, revealed that Hitler and his mistress, Eva Braun, had escaped from the ruins of Berlin.

When the defeat of the Third Reich loomed imminent, plans for Hitler's escape were drawn up by Martin Bormann, the Dictator's closest confidant. The project was entrusted to Admiral Karl Doenitz, Nazi U-boat specialist and Commander-in-Chief of the German Navy, who was later to boast:

"The German submarine fleet is proud of having built for Der Fuehrer in another part of the world a Shangri-La on Land - an impregnable fortress."

This "impregnable fortress" to which Admiral Doenitz had alluded was in the heart of a huge slice of Argentina territory that had been purchased by Nazi agents in South America. This "Little Nazi Germany" covered over 10,000 square miles of ranchland (the size of the state of Massachusetts) in the provinces of [blacked out] and [blacked out]. And the armed camp, that was to become Hitler's hideout, was in a region north of [blacked out].

Visits Nazi Outpost

Recently, in January, 1964, correspondent Jack Comben, journeyed to Bariloche to investigate reports of the Nazi outpost.

Here is his report:

“I have come back from visiting the post extraordinary surviving outpost of Hitler’s Germany in the world today.

“In a camp on the bank of the swift-flowing [blanked out] River, [blanked out]00 miles south of the Equator, in the heart of the Argentine, German men, women and children are living a strange and secret existence under steely discipline.

“Local people cannot penetrate into the camp, which lies at [blanked out], 100 miles north of [blanked out]. The inmates of the camp are forbidden to talk to strangers. All men in the camp wear Afrika Korps-style uniforms, with the same peaked caps that Field Marshal Rommel’s elite army wore in the Western desert.”

The camp is sealed off to all non-Nazis. No person without the proper credentials can set foot in it. Armed guards make sure of that. To further ensure secrecy, every piece of mail entering or leaving the camp is subjected to the most rigorous censorship.

“The camp,” reported Comben, “seems to be completely under the control of the camp commandant, a gray-haired man called [blanked out], who is known as Der Hauptmann. I have been able to establish that O[blanked out] was a high official in Hitler’s communications organization. His right-hand man is E[blanked out] F[blanked out], a former SS officer.”

Fake Suicide

When victorious Allied troops took over Berlin, the first reports out of the beleaguered city were that Hitler had killed himself in his bunker beneath the Reichchancellory. These reports said that Hitler and Eva Braun, whom he had married just before the fall of Berlin, took their lives in a suicide pact and that their bodies were then removed by trusted friends to the courtyard, drenched with gasoline and burned.

This version of what happened to Hitler and Eva was circulated throughout the entire world – but Allied Intelligence soon disclosed that the “suicide” was a hoax.

Members of Hitler's staff, who saw him a few minutes before his alleged death, contradicted each other as far as the suicide report was concerned.



by HARVEY WILSON

FOR the first time, an author has seen Adolf Hitler's secret-keeper hidden in the hills of Argentina.

The espionage network of the Third Reich had a secret, hidden in the mountains of the Andes, according to the Police Gazette, 1943.

Traveling through the mountainous region of the Argentine province of Mendoza, the author discovered the hidden hideout, according to the Police Gazette, 1943.

It was in 1938 that the Police Gazette, after having obtained the secret agent intelligence reports and information based on interviews with

former members of the Wehrmacht, revealed that Hitler and his mistress, Eva Braun, had escaped from the ruins of Berlin.

When the defeat of the Third Reich loomed imminent, plans for Hitler's escape were drawn up by Martin Bormann, the Dictator's closest confidant. The project was entrusted to Admiral Karl Doenitz, Nazi U-boat specialist and Commander-in-Chief of the German Navy, who was later to boast:

"The German submarine fleet is proud of having built for Der Fuehrer in another part of the world a Shangri-La on Land—an impregnable fortress."

This "impregnable fortress" was in the heart of a huge slice of Argentine territory that had been purchased by Nazi agents in South America. This "Little Nazi Germany"

Reporter confirms Police Gazette articles revealing

covered over 10,000 square miles of ranchland (the size of the state of Massachusetts) in the provinces of [redacted] and [redacted]. And the armed camp, that was to become Hitler's hideout, was in a region north of [redacted].

Visits Nazi Outpost

Recently, in January, 1964, correspondent Jack Comben, journeyed to Bariloche to investigate reports of the Nazi outpost. Here is his report:

"I have come back from visiting the most extraordinary surviving outpost of Hitler's Germany in the world today.

"In a camp on the bank of the swift-flowing [redacted] River, 100 miles south of the Equator, in the heart of the Argentine, German men, women and children are living a strange and secret existence under steady discipline.

"Local people cannot penetrate into the camp, which lies at [redacted] 100 miles north of [redacted]. The inmates of the camp are forbidden to talk to strangers. All men in the camp wear Afrika Korps-style uniforms, with the same peaked caps that Field Marshal Rommel's elite army wore in the Western desert."

The camp is sealed off to all non-Nazis. No person without the proper credentials can set foot in it. Armed

Police Gazette Article on Hitler's Survival of the War



covered over 10,000 square miles of ranchland (the size of the state of Massachusetts) in the provinces of [redacted] and [redacted]. And the armed camp, that was to become Hitler's hideout, was in a region north of [redacted].

Visits Nazi Outpost

Recently, in January, 1964, correspondent Jack Comben, journeyed to Bariloche to investigate reports of the Nazi outpost. Here is his report:

"I have come back from visiting the most extraordinary surviving outpost of Hitler's Germany in the world today.

"In a camp on the bank of the swift-flowing [redacted] River, 100 miles south of the Equator, in the heart of the Argentine, German men, women and children are living a strange and secret existence under steady discipline.

"Local people cannot penetrate into the camp, which lies at [redacted] 100 miles north of [redacted]. The inmates of the camp are forbidden to talk to strangers. All men in the camp wear Afrika Korps-style uniforms, with the same peaked caps that Field Marshal Rommel's elite army wore in the Western desert."

The camp is sealed off to all non-Nazis. No person without the proper credentials can set foot in it. Armed

Close up of Police Gazette Article on Hitler's Survival of the War

Stories of Adolf Hitler's survival of the war began to circulate almost immediately after the end of the European phase of the war, with various theories being offered for how he escaped and where he went. But the *Police Gazette* article contains something most of these reports and stories do not: *specifics*. Let us observe carefully what these are, for these points will assume much greater significance in the light of information to be presented in part three:

- 1) Long after the end of the war and the concoction of the Hitler suicide story under the aegis of British Intelligence – about which more in a moment – “Allied Intelligence,” according to the article, allegedly carried out investigations and compiled “reports and information based on interviews with former members of the Wehrmacht” to the effect that both Adolf and Eva Hitler had escaped Berlin;
- 2) The plans for this escape were completed by none other than Martin Bormann – whose probable escape from Berlin was examined in the previous chapter – who was aided and abetted in this effort by Grand Admiral Karl Dönitz;
- 3) Dönitz's now famous remark about the German Navy having constructed an “impregnable fortress” is then cited, though in a most unusual version, for in the normal version Dönitz is alleged to have located this “impregnable fortress” in a landscape covered in ice, which has led many to speculate that Dönitz was referring to a secret base constructed in Antarctica. In the *Police Gazette* version, however, the Grand Admiral is cited as simply indicating that the fortress was located “on Land;”
- 4) The location of this fortress is specifically stated in the article to be “in the heart of a huge slice of Argentina” purchased by Nazi agents prior to the end of the war;
- 5) The article specifically states that the region of Argentina in question covered some 10,000 square *miles* of land directly under Nazi control, and that this region was a remote wilderness area;

- 6) The “fortress” was surrounded by armed guards wearing “Afrika Korps” style uniforms and required the proper documentation to enter, a fact which in itself implies a high degree of organization and a normal chain of command;
- 7) The region in question was located near San Carlos de Bariloche, some 900 miles southwest of Buenos Aires; and finally,
- 8) That Hitler’s and Eva Braun-Hitler’s suicides in Berlin were faked. Given the previous allegation within the article of Bormann’s involvement in making these arrangements, it is reasonable to conclude that the same *modus operandi* was used – if the article is true – as was used in the escapes of Bormann and Müller themselves: falsified dental records, use of numerous body doubles, an escape by air, and an obfuscated “sequence of events” and a carefully rehearsed cover story.

Careful examination of the above points indicates two possible areas of corroboration, namely, 1) the alleged presence of Hitler in or near the environs of Bariloche, Argentina, after the war; and 2) the role of Martin Bormann as the architect of his escape. We shall reserve comments on Hitler’s alleged presence in Bariloche or its environs to the end of this chapter. For now, we shall address the problems posed by the history’s standard version of Adolf and Eva Hitler’s suicides.

B. Will the Real Adolf Hitler Please Die?

1. The Nexus Magazine Series by Giordan Smith

The March-April 2008 issue of *Nexus* magazine concludes a captivating and thought-provoking three-part series of articles by independent Australian historian and researcher Giordan Smith questioning the whole accepted version of Hitler’s last days in Berlin and his suicide. The question assumes some importance, in the light of the evidence and arguments that Mr. Smith presents, since I have argued in my two of my previous books on Nazi secret weapons, *Reich of the Black Sun* and *The SS Brotherhood of the Bell*, that the

malevolent outlines of some sort of “Nazi International” may clearly be detected in the post-war West and Latin America. Moreover, in my most recent book addressing the subject of the escape of top level Nazis Bormann, Kammler, and Müller, as was seen in the previous chapter, I outlined the shape of a powerful triumverate at the top of this International consisting of SS Obergruppenführers Heinrich “Gestapo” Mueller, Dr. Ing Hans Kammler, and Nazi Party Reichsleiter Martin Bormann. This triumverate, moreover, was the perfect combination to administer any ongoing Nazi International’s continuing and independent postwar development of the exotic technologies the Nazi regime had begun to investigate prior to and during the war, since the three represented a combination of security, administrative, and financial capabilities.

As most readers are also probably aware, more recently, Richard C. Hoagland and Mike Bara provided yet another approach to the possibility of the continuance of the Nazi ideological and technological agenda with their New York Times bestselling book *Dark Mission: The Secret History of NASA*. And as I observed in my own first two books on Nazi secret weapons, the presence and power of this post-war Nazi International does provide a way to speculatively rationalize the degeneration of American culture and politics into the increasingly Fascist avenues and mores of the police state “snitch culture” modern America has become. Similarly, it provides a method, as I outline in *The SS Brotherhood of the Bell*, of explaining and interpreting many of the odd events - otherwise inexplicable - towards the end of World War Two, up to, and beyond, the JFK assassination.

But as I also made clear in *Reich of the Black Sun*, I did not, at the time of writing that book, subscribe to the possibility of Adolf Hitler’s survival and escape from Berlin. But Giordan Smith’s *Nexus* series, and particularly the final part, raises the stakes significantly enough that I now begin to entertain the idea, and ponder its broader implications within the context of the scenario of the escape of Bormann, Müller, and Kammler. What if, after all, the chief himself *did* survive? And if he did, what does it mean in terms of the Nazi International and its covert post-war power, agenda, and influence?

Giordan's article in the March-April 2008 *Nexus* begins by pointing out the one major sticking point in the post-war Allied standard history of Hitler's suicide, the version concocted largely by Hugh Trevor-Roper and under the aegis of British intelligence. The sticking point, quite bluntly, is the consistent post-war Soviet attitude of skepticism toward the whole "death of Hitler in Berlin" scenario, a sticking point that was also seen with Stalin's own personal belief that Martin Bormann had also escaped the Reich, as was seen in the previous chapter.

Giordan Smith begins the third and final part of his series by noting that an American war correspondent in Berlin, one Joseph W. Grigg, announced on May 8, 1945, that Hitler's body had been found. But on May 10 the same Grigg reported that a further *four* bodies, "blackened and charred, that seem to answer to Hitler's general appearance" were drug out of the ruins of the Reichschancellery.² Ironically, this sounds remarkably similar to the four different versions of SS General Hans Kammler's death as I recounted in *Reich of the Black Sun* and as synopsised in the previous chapter. Within another five days, Grigg reported that the number of possible Hitler corpses had risen to *six*, forcing Grigg to admit that the Soviets were beginning to despair of making any definite identification of a body, and thus to have any definite or conclusive evidence of the fact that Adolf Hitler had indeed died!

The Soviets, notes Smith, continued to insist that they were skeptical. None other than Marshal Zhukov himself admitted, in a press conference on June 9, 1945 attended by representatives of the British, French, and American press, that the Russians "had found no corpses which could be Hitler's." The marshal added that he considered it a definite possibility that Hitler had escaped Berlin *by air*.³ Adding to the Allies' problems were the fact that Stalin, as is well known, confided to various American delegates at the Potsdam Conference that he believed Hitler had escaped.

Compounding the difficulties represented by the Soviets, Smith also points out that, once they *had* decided on a set of corpses to identify as Adolf and Eva Hitler's, these were in turn buried and unburied no less than three times, once at an undisclosed location in Berlin, then moved to Finov in the Soviet Union, and then once again

moved back to Germany and reburied in Rathenau. Even then the traveling corpses were not done, for they were exhumed once more and moved to Friedrichshafen. As Smith observes, “It would be hard to account for this macabre traveling show if the Soviets were sure that the bodies they had found were really those of the Hitler couple.”⁴

The ultimate origins of the suicide interpretation, as Smith points out, were Hitler’s chauffeur Erich Kempka, and Dr. Joseph Göbbels’ second in command at the Propaganda Ministry, Dr. Fritzsche. As Smith notes, this places the whole suicide legend in yet another problematical light, for London and Washington, which had maintained throughout the war the view “that the Nazis were unconscionable liars” there was, as regards the suicide story -even when one of the sources was Göbbels’ second in command! -a “dramatic shift away from skepticism”. In other words, “any Nazi who claimed to know that Hitler had committed suicide never risked having his or her veracity impugned. Clearly, all Nazis were liars - except those who told the Allies what they wanted to hear.”⁵

Smith observes that there are other significant problems with the suicide version as well, not the least of which is its most famous expositor: Hugh Trevor-Roper, the same Trevor-Roper who was taken in by the spurious Hitler diaries fraud in the 1980s.⁶ In other words, Trevor-Roper’s investigative skills do not, Smith implies, seem quite adequate to the task, the more so since he did not have access to any of the *Führerbunker* survivors in Soviet captivity, and was dependent on American summaries of interviews of detainees in the Russians’ possession. Here, observes Smith, Trevor-Roper seems to have been taken entirely by American fabrications of an interview with Hitler’s famous test pilot, Hannah Reitsch. But Reitsch herself later *repudiated* the interview as reported in Trevor-Roper’s book in no uncertain terms: “When I was released by the Americans, I read Trevor-Roper’s book, *The Last Days of Hitler*. Throughout the book, like a red line, runs an eyewitness report by Hanna Reitsch about the final days in the bunker. I never said it. I never wrote it. I never signed it. It was something they invented. Hitler died with total dignity.”⁷

The mention of Hanna Reitsch and her repudiation of the report as recorded by Trevor-Roper, raises what is perhaps the most glaring anomaly of them all in the suicide version: hers and General Robert Ritter von Greim's desperate and dangerous flight in a Fiesler Storch to Berlin in late April of 1945, and Reitsch's skillful landing of the small reconnaissance aircraft on a boulevard during a Russian artillery barrage. Many of us know the Trevor-Roper version of the story from the famous film, *Hitler's Last Ten Days*, starring Sir Alec Guinness as an increasingly deranged and insane Hitler, totally out of touch with military realities and living out his last desperate fantasies in the bunker, and clinging doggedly to his power, even at that late date, to make people serve his slightest whim, no matter how loony.

As was seen in the previous chapter, the story is that Hitler had Reitsch fly General Von Greim to Berlin to appoint him head of the Luftwaffe in the wake of Göring's attempt to seize the government, and Hitler's denunciation of the *Reichsmarschal* for treason. In the movie, a bewildered Reitsch and Von Greim are -quite reasonably - dumbfounded that they risked their lives for something so trivial. The point is made: Hitler was nuts, and the flight itself was foolhardy.

But, at this point, there is a serious discrepancy – as was seen in the previous chapter as well - and it has all the hallmarks of a cover story being put out. Notes Smith:

Why would Hitler, who was anxious for everyone *else* to leave Berlin, want someone to come *to* him? Why would he have been so keen to talk to the head of an almost non-existent entity?⁸ The official story fails to justify Greim and Reitsche's extremely dangerous flight. It also does not explain why the pair's flight from the Luftwaffe airbase at Rechlin near Berlin to Gatow airport on Berlin's periphery was accompanied by *an escort of 30-40 fighter jets*- in other words, the extant Luftwaffe virtually in its entirety. Clearly the flight had a more serious purpose than we have been led to believe."⁹

Smith even observes that it is Carter Hydrick's thesis that the flight was in fact to smuggle Martin Bormann out of Berlin! And note the new detail, for Smith alleges that the flight had a rather sturdy escort of almost 40 jet fighters. If true, then this means that the all-but-extinct Luftwaffe, now under the command of newly appointed and promoted Field Marshal Von Greim, was taking no chances that its cargo – whatever, or *whomever*, it was – was going to be shot down or forced away from its ultimate destination.¹⁰

Smith even presents eyewitness evidence of a Hitler Youth soldier who happened upon an SS radio post in Berlin, and of hearing a radio report that Hitler had received his birthday present and had been successfully flown out of Berlin by Hanna Reitsch in that very same Fiesler Storch! From there, the rest of the flight is recounted by Hanna Reitsch: she flew back to Rechlin, where Von Greim “attended a conference.” From there she and Von Greim flew to Plön, headquarters of Grand Admiral Karl Dönitz, then to Dobbin, headquarters of Field Marshal Keitel, then to Lübeck, and once again back to Plön, once again to see Dönitz. From there, in the strangest odyssey of all, she and Von Greim flew to the unlikely place of Königgrätz, in Bohemian Czechoslovakia! Could this last leg of the flight have been to coordinate something with the Kammler Group, something that could only be done in person and not over risky radio or phone communications? Perhaps.

To put it succinctly, Smith's reconstruction and Reitsch's own memoirs have her flying *to make contact with all the important figures in Carter Hydrick's escape scenario, and more besides, for her last flight also brings her into the proximity of Kammler's secret weapons think tank*. It looks, in other words, an awfully lot like last minute coordination was occurring, coordination that could *not* be entrusted to the normal telephone and radio communications of the High Command for the simple reason that it included human cargo.

It is here that Smith's three part series ends, and the real questions begin, for if one assumes that Hitler *did* survive, and moreover, escaped Berlin and Germany successfully, where did he go? And what did he do once he arrived there? It would simply be unreasonable in the extreme to assume that he went elsewhere in Europe. After all, as history's most notorious criminal, and having

just savaged Europe for five and a half years, there would have been no safe haven for him there. Only Franco's Nationalist Spain would have been relatively welcoming, and even then, Hitler would have been within easy reach of Allied or Soviet "special operations teams."

The only other possibility of a relatively secure and welcoming refuge would have been Latin America. There the situation would have been more secure, especially given the pro-Nazi sympathies of some Latin American governments in general, and of one in particular, as will be shown in the next chapter.

2. *Two Possibilities*

There are two other remaining possibilities that are disturbing, but that must be mentioned. One place, of course, for the ex-Führer of the totally eclipsed Greater German Reich to go would have been the alleged "secret base" in Antarctica. Even granting the very unlikely possibility that such a base actually existed, one cannot imagine Hitler, who had by this time become accustomed to living in some luxury, managing to be happy in a spartan and doubtless small living quarters surrounded by miles of cold and ice, and surviving on sea lions and penguins! Which leaves a final possibility...that Hitler's escape had been coordinated, not only by Bormann and his henchmen and using the standard means of doubles, doctored dental records, and so on, but with other outside parties, who decided to take him in and screen him in "thanks for a job well done." On this view, Hitler, in effect, went to ground with the very people who had put him into power. It would seem to take, at some point, the knowledge and connivance of a great power with the intelligence and security resources to keep a secret of that magnitude secret for that long, and to maintain for decades a cover story that looks increasingly to be as shaky as a pristine bullet on a stretcher in Dallas, Texas, in 1963.

Of these possibilities, then, we end with two as being the most probable, if the escape scenario is true, and both of them end with "America."

But as will now be shown, the most likely of these two possibilities ends with *Latin America*, and with the Nazi International's most

hospitable host: Argentina, and dictator Juan Domingo Perón.

C. Back to Velasco's Story: Hitler's Escape, and Eva Braun's Death

The allegations of Don Angel Alcazar de Velasco concerning Bormann's escape from Berlin – and his arrangement of Hitler's escape – were already touched upon in the previous chapter. Certain details of those allegations, however, now need to be stated more explicitly. Here are the relevant passages from Velasco's story as recounted in his letter to Sharhunters International founder Harry Cooper:

From what Bormann told me and from what I saw in those last hours in the bunker I have almost satisfied myself as to what actually happened to Hitler. I know that many people who remained in the bunker after I have left (sic) have given their own explanation of what took place there and their accounts are possibly more acceptable than mine. In fact, I do not attempt to discredit them.

But on the evidence as I know it, this is my reconstruction. A few minutes after Hitler had disappeared up the steps leading out of the Führerbunker I saw for myself a man who bore a startling resemblance to Hitler in stature and facial features being escorted by three uniformed SS officers into the Führer's private apartments. *It was commonly accepted that there was on the Führer's staff, a man who was said to be his double.*

In conversations with Bormann, he was insistent that Hitler had been removed from the bunker under the influence of drugs on April 21st – the day I shook hands with him in the bunker corridor. Bormann would not give me any explanation as to how many apparently reliable witnesses had claimed to have seen and spoken to Hitler in the bunker right up until his reported suicide on April 30th, except to say that as creator of the Hitler suicide myth he had seen to it that all participants had been carefully briefed.

*It is only left to me to believe that it was Hitler's double who, nine days after I left, was destined to play this most important role in the history of Nazism. It was this man who was shot through the mouth and whose body, dressed in Hitler's uniform, was burned alongside that of Eva Braun in the Chancery garden that same afternoon.*¹¹

A little further on, Velasco elaborates more completely on why Bormann had Hitler drugged, and on why Eva Braun-Hitler did not escape with him:

Bormann had left orders that the Führer was to be drugged by force if necessary, and taken out of Berlin. That's what happened.

.....

When Bormann appeared at the bunker the last time, Hitler was still determined to stay and if necessary, prepared to die defending the capital with the phantom legions which, by then, existed only in his mind. But Bormann had already assumed command and gave orders that both Hitler and Eva Braun were to be evacuated from the bunker. ***They were both forcibly drugged with, it turned out, fatal results for Eva Braun.***

....

The knowledge that Bormann had countermanded the Führer's last wish left us stunned. It seemed incredible that Martin Bormann, the man who had been Hitler's faithful lieutenant for twenty years, could perform such a "*volte face*." I had to wait almost a year to hear, from Bormann himself, the true reason for this seeming piece of treachery.¹²

Velasco would not learn of Bormann's reasons for the drugging of Hitler and Eva Braun until both he and Bormann were allegedly on a "black" unregistered U-boat bound for Argentina from Spain.

On the U-boat, Bormann allegedly finally confided to Velasco his reasons for the forcible removal of the Führer from the bunker and Berlin:

Then he told me the incredible story of Hitler's fate. He said
"Listen to me carefully and remember what I say. It is true. When Adolf Hitler left the Führerbunker, he was barely conscious of what was happening. After months of fighting the enemy on the battlefield and the treachery in his own camp,¹³ he was both mentally and physically exhausted.

*"But time and again he expressed to me his resolution to die with German soldiers around him. This I could not allow to happen. Hitler was the embodiment of the National Socialist cause. One could not survive without the other. **At least not then.***

"By the 21st of April (1945) it was obvious that the war was lost. It became necessary to countermand the Führer's wishes and remove him physically from the bunker. I arranged to have him driven secretly from Berlin to Rottach am Egern, escorted by officers from my personal staff. Only a handful of people besides myself knew that the Führer was there, and these were people who I knew could be trusted to keep the secret of his escape for as long as it was necessary.

"From Rottach he was driven across Germany and smuggled by ship to Norway. Two of my agents kept him in a place many miles from the nearest village until arrangements were completed for him to leave Europe.

I asked, *"What of Eva Braun and the suicide?"*

"Eva Braun never arrived in Norway. Unfortunately she was given an overdose of drugs from which she later died. As for the suicide, I was the author of the story that Hitler and Eva Braun committed suicide and their bodies were burned with petrol. Those witnesses who afterwards testified to this end had been carefully briefed on my instructions."

Bormann leaned intently across the table; *"That Hitler did not die I know. I also know that he is still alive but more than that I am not prepared at the moment, to tell you."* And with that I had to be content.¹⁴

If one were to rely solely upon Velasco's account, one would be inclined to dismiss the whole story as a pure fabrication, notwithstanding his accurate statement that Grand Admiral Dönitz was in Berlin on the precise day that Velasco maintains that Hitler was forcibly removed from the bunker, and a double planted in his place.

1. Analysis and Reconciliation of Scenarios

It is when viewed in the wider context of (1) Carter Hydrick's plausible reconstruction of the scenario of Bormann and Müller's escape from Berlin on the night of April 30th, via the Fieseler Storch piloted by Hanna Reitsch and Robert Von Greim, (2) the questions raised from the public record and standard history that were uncovered by Giordan Smith in his *Nexus* series, and (3) the 1964 *Police Gazette* article about Hitler's presence in the environs of Bariloche, Argentina, that the details of Velasco's story require a second look and much closer analysis and scrutiny.

Careful reading and an analysis of the implications of the above excerpts from Velasco's allegations will reveal the following points and implications:

- 1) Hitler was forcibly removed, on Bormann's orders, from Berlin on April 21, 1945, *nine days prior* to his "suicide" in the standard history on April 30th;
- 2) Hitler – and Eva Braun – were forcibly drugged to accomplish this;
- 3) The time-tested Bormann-Müller *modus operandi* of substituting a double was used not only in *their* escapes, but Hitler's as well;
- 4) Eva Braun died of an "overdose" of the drug intended to render hers and Hitler's forcible removals possible;
- 5) Bormann had carefully briefed the remaining people in the bunker – presumably during the period from Hitler's departure on the 21st to his own departure (according to the Hydrick scenario) on the 30th – on what their "cover story", i.e., the suicide myth, would be;

6) Hitler escapes to *Norway*, and thence, presumably, via some route indirectly, or directly, via U-boat (and hence the succession of power to Dönitz) to some safe haven outside of Europe;

7) Bormann needed Hitler alive, “*at least for the moment,*” to paraphrase Velasco’s account, in order to ensure the *near-future* survival of Nazism

When this seemingly straightforward list of Velasco’s allegations is compared with the standard record, and its own inherent implications are considered, the following implications emerge, none of which contradict Hydrick’s careful reconstruction of Bormann’s and Müller’s escape, and which, moreover, broadly corroborate it since the same methods are in play, and the same escape route is used:

1) Consider first the matter of Eva Braun’s “overdose.” According to the standard version of history, Eva Braun married Adolf Hitler in a small civil ceremony in the bunker on April 30th, in the early hours of the morning. Some twelve hours later, she allegedly bit into a cyanide capsule, committing suicide. Hitler followed her by allegedly shooting himself in the temple, or, depending on the version, in the mouth. The SS orderly who attended them was ordered to wait ten minutes after he heard the pistol shot, then enter their apartments. The bodies were to be removed and burned.

But according to Stalin’s firm conviction, Bormann escaped with *two* other men and *one* woman, most likely, as we have seen, on the flight of Hanna Reitsch and General Ritter Von Greim, from Berlin, on April 30th. Reitsch would account for the woman (indeed, she *had* to be on the flight since only she could pilot the plane out of Berlin, due to injuries Von Greim had suffered during their flight into the city). Therefore, *Eva Braun did not escape on the April 30th flight*, and according to Velasco’s account, did not escape at all.

Is there any way to corroborate this?

There is, though again, it is a speculative possibility based on combinations of *all* the accounts – the standard history, the

Hydrick scenario, and the Velasco allegations. According to the standard version, Eva Braun, when she began to sign her name to the marriage certificate, began to sign as Eva *Braun*, but, as she did so, realized she was now Frau Hitler, and crossed her maiden name out, and wrote Hitler instead. The standard history explains this mistake as a normal human error.

But there is another possibility. If indeed Bormann had successfully substituted a double for Hitler, and if he had no intention of rescuing Eva Braun, then keeping her drugged throughout her last days in Berlin may have been a necessity in order to perpetuate the fraud of the substitution of the double. Moreover, the marriage itself between the double "Hitler" and Eva Braun may have been concocted by Bormann himself as part of the cover story. Under these circumstances, Eva Braun made her mistake signing the marriage certificate not out of ordinary human error, but under the influence of drugs. When one reads Velasco's account, there hovers over it the dark possibility that Eva Braun's "overdose" was thus not accidental, but a deliberate sacrifice of her on Bormann's part to make the whole thing work, and to cut down on the number of "unnecessary personnel" that he had to smuggle out of Berlin.

2) Consider secondly the implications of Velasco's *total* account, for clearly by the time Bormann has Hitler forcibly drugged, it is *Bormann* and *not Hitler* who is calling the shots. In other words, under the pretence of acting out of loyalty and friendship for the Führer and the wider Nazi cause, by drugging Hitler and removing him from the bunker, Bormann has in effect staged a *coup d'état*.

There is another factor in Velasco's account that reinforces this view, and that is his insistence that *Grand Admiral Dönitz* was not only present in Berlin but present in the bunker as this *coup d'état* was being orchestrated and Hitler was being removed on April 21, 1945. If Velasco's account is true, and if its *implications* as analyzed here are true, then the Admiral would indeed *have* to be present in Berlin in order to work out the details of the cover story and of Hitler's transfer to Norway, since the Admiral would ultimately be responsible for it. Such sensitive

matters simply could not have been trusted to telephone lines or radio communications, which would have been capable of interception and decoding by the Allies. To make the scheme work, nothing could be left to chance. Thus, this part of Velasco's account – regardless of its external corroboration by Sharkhunters founder Harry Cooper – rings true on the basis of the internal logic of the situation.

Moreover, it sheds yet a new light on the shenanigans between Dönitz – loyal to Hitler out of his sense of military duty and honor – and Bormann, not only over the transfer of authority from Hitler to the Admiral, but over the control of U-234, for these details might possibly have been agreed upon between Bormann and the Grand Admiral during the latter's visit to the bunker on April 21! Thus, the whole strange struggle between the Bunker and Dönitz for the control of U-234 as recounted in the previous chapter might have been one vast charade to further confound any listening Allied ears. This too fits the Bormann method of operation. Once the *coup d'état-by-drugs* had been staged on April 21st, Bormann could have a drugged Hitler – or his double for that matter – sign any last political will and testament Bormann wished. It is in this light that Velasco's allegations of Bormann's statements to him of his reasons for forcibly removing Hitler from the bunker should be considered, for Bormann merely needed Hitler alive as a symbol of the continuity of the cause, and of the organization he was self-evidently putting into place and intending to control himself.

In short, as far as Bormann was concerned, Hitler was expendable....but not just yet.

3) Finally, consider the implications of the *escape route* together with the Hydrick scenario and the *Police Gazette* article. If Hitler had indeed been smuggled to Norway, it would have been a comparatively simple matter to see to it that he was embarked on the U-234 before the latter left Norway to return to Germany to pick up Bormann and Müller. Naturally, Bormann would *not* have informed his American partners that, in addition to uranium-235 and valuable infrared proximity fuses on the submarine, that it also carried not only himself

and Müller, but Hitler himself! Thus, under the cover he knew the Americans would give the U-234, he managed, if the above highly speculative reconstruction be true, to smuggle not only himself and Müller to safety, but the very personal symbol of Nazism itself: Adolf Hitler.

Granted, while the above reconciliation of scenarios is highly speculative, it should be noted that its truthfulness or lack thereof does *not* diminish the plausibility of Hydrick's own scenario and the likelihood of *Bormann's and Müller's* escapes. That remains intact and stands on its own case, whether or not Velasco's allegations are true.

That being said, however, it is also evident that Velasco's scenario is not only easily reconciled in its main points with Hydrick's reconstruction, but moreover, corroborates Bormann's and Müller's methods of operation.

2. Corroboration from Argentina

So what of the *end* of this journey? Is there corroboration of the 1964 *Police Gazette* article that Adolf Hitler was indeed somewhere in the environs of Bariloche, Argentina, and thus that Velasco's allegations in their broad outlines might, after all, be true?

Indeed, and unfortunately, there is.

Sharkhunters founder Harry Cooper led an expedition to a place he calls "Stadt," in Argentina. Cooper deliberately does not say where this place is in order to protect the innocent people involved. With his Argentine guide, he visited a place called simply the *Estancia*, the "ranch," a large compound. Contacting the manager of the ranch, Cooper recounts this story:

We were doing fine with the conversation until we told the manager that one of our associates had spoken with a woman who had been the cook on the '*Estancia*' many years ago, and she told us that she remembered very clearly cooking for Adolf Hitler *and Eva Braun* when they were guests at the '*Estancia*' in winter (July, August, September of 1945....months after the reported suicide in Berlin.)

He looked at us with an empty stare. So we asked him point blank if he would confirm the dates that Hitler was on the '*Estancia*'.

It would have been quite simple for him to take the easy route and merely tell us that he was much too young and the war years were far earlier than he was even born. Instead, he said:

*"I am not allowed to speak about that."*¹⁵

Apart from the fact that the alleged presence of Eva Braun-Hitler at the *Estancia* conflicts with Velasco's account, the broad corroboration of the *Police Gazette* article now comes from a new anecdotal source: an Argentine ranch manager who clearly knew something, but was under pressure not to talk about it.

The question is, pressure from whom?

But from the *Police Gazette* article we have learned something more: Hitler was said to be present somewhere within 100 miles or so of Bariloche.

Do not forget that name, for if the corroboration seems a little thin now, there are far more goings on in Bariloche than meet the eye, as will be seen in Part Three...

¹ Giordan Smith, *Nexus* March-April 2008, p. 41, emphasis added.

² *Nexus*, March-April 2008, p. 35

³ *Ibid.*

⁴ *Ibid.*

⁵ *Nexus* March-April 2008, p. 37.

⁶ Trevor-Roper's gullibility in this matter can hardly be emphasized too much, for on the face of it, does it seem *reasonable* that Adolf Hitler, busily running "his" war from his various headquarters with a micro-management style worthy of a modern globalist corporation towards its employees, would have time to keep a *diary*!?

⁷ *Nexus*, March-April 2008, p. 38.

⁸ i.e, the Luftwaffe.

⁹ *Nexus*, March-April 2008, p, 41, emphasis added.

¹⁰ As of this writing, I have not been able to corroborate Smith's assertion about the fighter escort, though his actual *numbers* are not in dispute, as the Luftwaffe still had several operational Messerschmitt 262 jet fighters at its disposal. Getting that amount of fighters to assemble and be fueled and loaded for escort operations at that late date in the war, however, would have been difficult. Not impossible, but difficult.

¹¹ Don Angel Alcazar de Velasco, *Escape from the Bunker*, ed Harry Cooper, p. 24, emphasis added.

¹² *Ibid.*, p. 28, bold and italicized emphasis added.

¹³ Perhaps a reference to the attempt by Göring to seize power from Hitler, and to the secret attempts by Himmler to negotiate a surrender to the Western Allies. For my rationalization of Himmler's reasons for why he thought he might have something to offer the western Allies, see my *Reich of the Black Sun*, p. 156.

¹⁴ Don Angel Alcazar de Velasco, *Escape from the Bunker*, p. 55, italicized emphasis in the original, bold and italicized emphasis added.

¹⁵ Harry Cooper, "Argentina's Place in the War," *KTB #210: The Official History Publication of the U-Bootwaffe*, Volume 26 July 2008 Number 5, Sharkhunters, p. 8, emphasis in the original.



**“The Rodents at the Other End
of the Ratlines:”
Juan Domingo Perón and
the Vatican Connection**

*“Perón’s resounding triumph in the presidential elections of
24
February 1946 set the stage for the massive evacuation of Nazi
fugitives
from Europe to Argentina.”
Uki Goñi¹*

The evidence hitherto presented indicates that the Nazis fleeing Europe for safe havens elsewhere, usually Latin America and the Middle East, did so via stopovers in Nationalist Spain. And given the massive size of Bormann’s strategic evacuation plan, not only were massive amounts of liquid capital and assets to be transferred to safe neutral countries, but enormous technical data, personnel, and resources as well. Certainly the corporate connections available to Bormann via his close relationship with I.G. Farben chief Hermann Schmitz would give him enormous capabilities to create a tapestry of dummy corporations and interlocking directorates to move the actual cash out of Europe. And with his ability to control certain “black” U-boats directly, harder assets could be similarly moved.

But moving *personnel and technical equipment, papers, and plans* would require something different.

Bormann had to have help.

This raises the all important and over-looked question of just who was at the *other* end of the ratlines smuggling Nazis out of Europe. Much, of course, has been written of the Vatican's role in these operations, and as will be discovered here, it was in fact involved. Even then, however, fleeing Nazis had to have someplace to *go*, especially if Bormann intended his Nazi International to continue independent scientific research begun in the Third Reich, and to take a real though covert hand in postwar politics.

This insight allows one to establish an inventory of what precise criteria Bormann's Nazi International would need as a base of operations, given the intention to continue independent research, and given a presumptive intention to orchestrate economic and political events for an eventual recrudescence of Nazism. Bormann would need:

- 1) A neutral country large enough and with enough "wilderness" or remote areas, to safely house large amounts of people;
- 2) Similarly, it must also be *accessible*;
- 3) The government must be friendly to Nazism and amenable to a large Nazi presence;
- 4) The country must be technologically sophisticated enough to support whatever scientific research projects the Nazi International wished to accomplish, or able to import sophisticated equipment via German business contacts when needed (see point 6 below);
- 5) There must be sufficient territory within the country to *hide* such a project, or at least keep it as far from public scrutiny as possible; thus, on this view, even Nationalist Spain is out as is Sweden, Portugal, etc; in short, a European base for the Nazi International, much less any research project it may wish to continue, is out of the question;
- 6) There must be sufficient German business penetration to permit the easy transfer of funds into and out of Nazi accounts and also permitting the liquidation of harder assets into liquid capital.

And there is one more item to add to the list, given the Vatican's well-known participation in helping fleeing Nazis:

- 7) It most likely will be a area with a predominantly Roman Catholic population.

When one considers this list, Latin America immediately offers itself as a fulfillment of most of the criteria. However, the requirement of a Nazi-sympathizing government narrows the list down substantially to Chile, Argentina, Bolivia, Paraguay, and to some extent, Brazil. And of these five, there is one in particular that stands out, and that will *increasingly* do so as our analysis proceeds:

Argentina.

A. The Colonels, the Colonel, and the Beginning of a Courtship

Argentine journalist and researcher Uki Goñi filled a much-needed gap in the growing literature concerning the Nazi ratlines with his book *The Real ODESSA: How Perón Brought the Nazi War Criminals to Argentina*, for in it he tells the story of the little known Argentine side of the ratlines, and of the crucial role Argentine dictator Juan Domingo Perón played in ferrying Nazis to his country and giving them asylum. Through careful sifting of the remaining documents concerning this activity in the Argentine national archives, Goñi demonstrates how the ratlines would not have been successful without the involvement of a major Latin American government with the resources to harbor hundreds – if not thousands – of Nazis. In doing so, as we shall see, he also documents how Bormann's plans for ongoing Nazi research could not have been accomplished without the help of the Argentine dictator, even though Goñi himself does not adhere to the view that Bormann escaped from Berlin.² While the case for Bormann's probable postwar involvement in an ongoing independent Nazi research project is made in part three, examining Perón's role in helping Nazis escape to Argentina will disclose the dictator's own political motivation for this nefarious activity, and why Perón would also have wished to sponsor Nazi research in his country.

1. Historical Background

a. Perón in Europe

As Perón confided when he was dictating his memoirs during his exile to Nationalist Spain between the end of his second presidency and his triumphant return to Argentina in the 1970s, he had serious “misgivings” about the rightness of the Nuremberg War Crimes Tribunals:

In Nuremberg at that time something was taking place that I personally considered a disgrace and an unfortunate lesson for the future of humanity.... I became certain that the Argentine people also considered the Nuremberg process a disgrace, unworthy of the victors, who behaved as if they hadn't been victorious. Now we realize that they (the Allies) deserved to lose the war. During my government I often delivered speeches against Nuremberg, which is an outrage history will not forgive!³

Whatever the legal and moral merits or lack thereof of the Nuremberg trials – consider only the presence of the representatives of Stalin's regime as judges at the affair – Perón's attitude was obviously firmly maintained by him long after his first two presidencies.

Whenever and for whatever reasons Perón first developed his sympathies for Nazism and the Third Reich, there can be no doubt that these crystallized when the young Perón, then an officer in the Argentine army, was sent on a tour of Europe in 1938. Sent to tour various European countries as a military observer, Perón cultivated many contacts in Fascist Italy and Germany. According to Goñi, however, Perón was also present in Europe in 1942, receiving special military training in Mussolini's army. Goñi also indicates that Perón was granted an audience with Pope Pius XII (Eugenio Pacelli), and that he met Argentine special diplomatic envoy Juan Carlos Goyeneche, who had been sent on a special mission to Berlin by then Argentine President Castillo.⁴

b. Argentina and the Axis

Castillo's regime in Argentina began to court the Axis powers, and particularly Nazi Germany, during the "Axis high tide" of the summer of 1942, as Hitler's armies continued lunging deep into Soviet Russia and Rommel's Afrika Korps raced across the Libyan and Egyptian deserts. Castillo, "a weak civilian president," walked a diplomatic tightrope, carefully maintaining "a façade of neutrality while his leading civilian and military advisors circumvented normal diplomatic channels and sought direct contact with Berlin."⁵

In this case, the normal diplomatic channels were circumvented by a special Argentine envoy, a young "Catholic nationalist" whose grandfather had once been President of Uruguay, and "whose father had been mayor of Buenos Aires" prior to the Second World War.⁶ The envoy's name was Juan Carlos Goyeneche, and he was a close friend and "confidential agent" of Colonel Juan Domingo Perón. Additionally, Goyeneche had cultivated close contacts among the foreign intelligence branch of the SS which had a heavy human on-the-ground presence in Argentina prior to and during the war.⁷ As Goñi observes, this network of agents "was connected to Berlin via an array of secret transmitters known as the 'Bolivar Network' that covered much of the country."⁸

In 1942, Goyeneche departed for Europe via Nationalist Spain, whence he traveled onward to Fascist Italy. There, according to Goñi, using Argentine diplomatic contacts in Spain, he was able to develop close ties to Giovanni Cardinal Montini,⁹ at that time working in the Vatican Secretariat of State. Montini, of course, will figure more prominently in the story in due course, but for now it simply should be noted that it was Montini who would eventually be elected Pope Paul VI and preside over the conclusion of the Second Vatican Council.

1. The Argentine Special Envoy and Von Ribbentrop

From Italy, Goyeneche eventually made his way to his ultimate destination, Berlin, in October of 1942. Once in Berlin,

He left immediately to visit Franco's Blue Division on the Russian Front with his old friend Gottfried Sandstede, the former press attaché at the German embassy in Buenos Aires. Sandstede was a Schellenberg agent who had been forced to abandon Argentina when his spying activities became too evident.¹⁰

Once Goyeneche and Sandstede returned to Berlin, Goyeneche was contacted by members of the Latin American bureau of the German Foreign Ministry, and a meeting was arranged between the special envoy and the German Foreign Minister, Joachim Von Ribbentrop.

This meeting took place on November 30, 1942, at Von Ribbentrop's estate in Westfalen, and according to Goñi, lasted several hours, with Gottfried Sandstede acting as interpreter between Goyeneche and Von Ribbentrop.¹¹ The purpose of Goyeneche's visit is illuminating, for he sought German assistance and support "for a nationalist candidate in the upcoming 1943 presidential elections...or failing that, support for a coup that would maintain the 'neutral' Castillo in office."¹² Perón, in other words, was already beginning to plot, and looking to Nazis for help.

It is in Von Ribbentrop's replies, however, that one can discern the exact broad outlines of the Argentine-Nazi relationship beginning to develop. After a lengthy anti-Jewish rant, the Foreign Minister

then proceeded to answer the three specific questions Goyeneche had regarding Argentina: first, would Germany acquire Argentine products after the war? "If Argentina *maintains its present stand, she will profit from it greatly over the countries which have not taken such a stand,*" he answered. "We could take everything that Argentina produced no matter how much it might be."

Second, did Germany recognize Argentina's rights over the Falklands? "England is our enemy... Gibraltar is truly a grotesque example in this story, for certainly nobody can question that it lies on the Iberian Peninsula. Likewise, the Falklands are at least nearer Argentina than to England.

Therefore, we have great sympathy for the justifiable Argentine interest. *But I believe that unless Argentina takes care, it may be that the United States will take over these islands.*"

And third, *did Hitler agree that Spain constituted the "natural bridge" between Argentina and Europe?* "The establishment of her cultural and spiritual relationship with Europe is in the first rank of Argentine duties. *We shall in any case constantly promote the existing unity between Spain and Argentina.*"¹³

Von Ribbentrop's cagily diplomatic answers – and Goyeneche's equally cagey questions - must be viewed in the context of what had just occurred on the Russian Front, for the Soviets had just begun to launch the massive counteroffensive at Stalingrad that would eventually lead to the decimation and surrender of Von Paulus' Sixth Army.

In brief, Goyeneche, who had been sent to Berlin with the ostensible purpose of negotiating a secretive alliance with the Axis, was now faced with changed circumstances, as were the Germans. We have already seen how top Nazi leaders began in the light of that looming disaster to make postwar plans. Von Ribbentrop, if not at the very top, was close enough to it that he would have known of these plans and their implications for Nazi diplomacy.

In that context, then, his answers to Goyeneche's three questions deserve closer scrutiny. First, note that Von Ribbentrop states that Germany would certainly need Argentine products *if* Argentina maintained its "present stance," i.e., remained *out* of the war and ostensibly neutral. While the disaster at Stalingrad had not yet unfolded into its full horror, the threat clearly loomed, and Von Ribbentrop knew it. He was quietly though emphatically telling Argentina to stay out of the war and remain neutral.

The German Foreign Minister's response to Goyeneche's second question only reinforces this interpretation, for after expressing Nazi Germany's sympathy for Argentine claims over the Falklands, he then states unequivocally that "I believe that unless *Argentina takes care, it may be that the United States will take over these islands.*" That is, if Argentina either entered the war overtly as an Axis ally, or

demonstrated too overt of a proAxis sympathy, Argentina might be faced with a far graver threat than the United Kingdom, namely, the United States. This is the clearest possible indication not only that the German Foreign Ministry wanted to keep Argentina *out* of the war, but was already laying the diplomatic foundations for a postwar evacuation of Nazism to that country.

This places Goyeneche's third question and Von Ribbentropp's response to it in a new light, for behind Goyeneche's round-about question about German attitudes toward Nationalist Spain, he is really trying to make sure he has understood Von Ribbentropp correctly. The question asked was "Does Germany view Spain as a bridge between Europe and Argentina?" but the implied question was "Does Germany intend to invade Spain?" Von Ribbentropp's reply is equally diplomatic, but equally clear: "Germany respects Spain's cultural ties to Argentina, and Argentina's cultural ties to Europe via Spain," in other words, "No, Germany will not invade Spain, for it will be needed as a bridge between Europe and Argentina." For Goyeneche, and ultimately for Goyeneche's mentor and friend Juan Perón, the meaning was clear: the military situation was lost, and other plans had now to be put in place, and Spain was a key component of those plans.

2. An Unusual Encounter Between Representatives of the SS and Allen Dulles

But what of Goyeneche's request to Von Ribbentropp for German support of a "nationalist candidate" in Argentina's upcoming presidential election? The answer lies, perhaps, in Goyeneche's next appointment in Berlin, for there he met with none other than Walter Schellenberg, the notorious head of Himmler's Foreign Intelligence Service of the *Sicherheitdienst*. Schellenberg, a competent intelligence professional, had repeatedly warned the Nazi leadership that the United States' enormous war production potential would eventually turn the war against the Reich. These warnings, unheeded, prompted Schellenberg to initiate a series of private peace overtures to the Western Allies utilizing his large network of

spies and contacts. One of these overtures is worth mentioning, for it concerns none other than – once again – Allen Dulles, America’s OSS station chief in Switzerland:

The most daring of these peace overtures took place in 1943 through Schellenberg’s “special sources” Max Von Hohenlohe and Reinhard Spitzzy, *representatives in Madrid of the Skoda arms firm*. They held a number of meetings in Berne with Allen Dulles, overseer of the American Office of Strategic Services (OSS) in Europe. In the lengthy report drawn up by Spitzzy of these talks, the position taken by the American spy chief is spine-chilling: “He (Dulles) was fed up with listening all the time to outdated politicians, émigrés and prejudiced Jews. In his view a peace had to be made in Europe... while he had scant sympathy for Soviet Russia, *he did not reject National Socialism in its basic ideas and deeds... he added that it would be unbearable for any decent European to think that the Jews might return someday.*” Interestingly enough, Spitzzy was also one of Schellenberg’s “channels” for information about Argentina, one that bypassed the normal intelligence chain. Only a few months after the Dulles talks, *Spitzzy would be attempting to negotiate a secret arms deal with one of Perón’s colonels in Madrid with Schellenberg’s support.*¹⁴

There are a number of speculative implications to unpack here, and it is best to do so before proceeding.

First, note that Schellenberg’s contacts with Dulles are representatives of the Skoda munitions works in Pilsen, Czechoslovakia. Skoda’s engineering division was, of course, the front for SS *Obergruppenführer* Hans Kammler’s secret weapons think tank. Consequently, it *is possible* that Dulles, via these contacts, learned *something* about the Kammler Group from these individuals, though certainly he would have only seen the tip of the iceberg. The reason that this possibility must be entertained is because, as I pointed out in my book *Reich of the Black Sun*, General Patton’s U.S. Third Army thrusts at the end of the war, if

compared to the known headquarters and installations of Kammler's secret weapons "think tank," appear to have been guided unerringly to many of them. As I indicated there, this would imply that at some extraordinarily high level, the Third Army was being ultimately guided by an intelligence agenda.¹⁵ This meeting may be yet another small clue that this possibility was indeed the case.

Secondly, note Dulles' response to this overture as recounted by Spitzzy himself. In all fairness to Dulles, it may be that his response was designed to let the German "hear what they wanted to hear," but Dulles *did* send out private feelers and attempt to persuade the American leadership that a separate peace might actually be desirable. But if his response represents a *genuine and heartfelt conviction* on his part, then his subsequent dealings with German military intelligence chief Reinhard Gehlen, not to mention his statement to Paul Manning that he was "on the right track," take on a more sinister significance. The fact that Schellenberg's agents deliberately sought Dulles out suggests that Dulles' character and sympathies were well known to Schellenberg.

Finally, note that Spitzzy is in turn involved in negotiating an arms deal for one of Perón's agents in Madrid. This implies that Goyeneche's question about German support for a "suitable" candidate in Argentina's upcoming presidential elections had met with a favorable response, for Germany was prepared to arm Perón's associates in case the necessity for a coup presented itself.

3. *The Colonels' Coup*

In early January, 1943, as the Germans' military situation at Stalingrad was reaching its disastrous denouement, Goyeneche visited Heinrich Himmler at the latter's eastern front headquarters. The conversation was of a general nature, though Himmler asked Goyeneche to convey a favorable impression of the *Reichsführer* to Pius XII on the latter's upcoming visit to Rome.¹⁶ From Berlin, Goyeneche returned once more to Madrid, where he lunched with Spain's foreign minister, Ramón Serrano Suñer, discussing his impending visit to Pope Pius XII and Benito Mussolini. Goñi reveals more about the Argentine special envoy's purpose, for he

was organizing a conference of pro-Axis Catholic delegates from Vichy France, Hungary, Romania, Slovenia, Italy, Spain and Portugal, who would meet in Rome to integrate the Christian order in the New Order. [17](#)

Journeying on to Rome, Goyeneche met twice with Giovanni Cardinal Montini, and then with Pope Pius XII who urged Argentina to preserve its neutrality. The Pope went so far as to draft a message in support of Argentina's neutrality.[18](#) After this, the special envoy met with Benito Mussolini, who communicated Fascist Italy's secret support for a coup.[19](#)

On June 4, 1943, all these maneuverings on the part of Perónist Goyeneche, the Axis, and the Vatican, were finally rewarded when a group of colonels led by Perón finally overthrew Castillo, ejecting him from the presidential mansion, the Casa Rosada.

However, it is worth noting, the outlines of the postwar Nazi International that began to take shape during this time period, when the military initiative passed irrevocably from the Axis to the Allies in the wake of the disaster at Stalingrad and the British victory at El Alamein in North Africa.

As was seen above, the most likely initial purpose of Goyeneche's visit to Germany in 1942-1943 was to solicit German support for just such a coup, and further, to enter a secretive alliance with the Axis powers. Dissuaded in this course by Ribbentrop's diplomatic answers, the next best thing was concluded: the installation of a pro-Axis "neutral" regime in Buenos Aires. More importantly, as Goñi's account reveals, the Argentine effort was fully complicit in the attempt to "internationalize" Nazism by linking to the various pro-Nazi factions in the various puppet governments of Europe, and this effort centered furthermore on tacit Vatican support. This "internationalizing" of Nazism around a German core was already hinted at by Wilhelm Landig in his science fiction novels, which, once again, appear indeed to be "full of realities."

Once Perón's colonels were in power, moreover, secret collaboration began in earnest:

A partnership with Argentina's military had already been formalized. As he told American interrogators after the war, SD chief Walter Schellenberg had approved "an agreement for mutual collaboration" in May 1943. It included freedom from arrest for Nazi agents in Argentina, camouflage identification for them as members of the Argentine secret service, the use of the Argentine diplomatic pouch for transporting "secret material" between Buenos Aires and Berlin, and even an early warning system in case of a "cabinet crisis" that could endanger German agents. In return, Argentina's military were allowed access to the powerful radio communications network of the Nazi secret service, were provided with information culled from Nazi sources in Argentina's neighboring countries and were promised collaboration in forming an Argentine-led South American bloc of nations.²⁰

Another avenue for items out of Europe to Argentina thus emerges, for under the cloak of Argentina's diplomatic pouch, and as a component of his strategic evacuation plan, Bormann could smuggle almost anything out of the collapsing Reich, especially sensitive documents, files, and blueprints. Additionally, with the suggestion of Nazi collaboration to assist Argentina in forming a "bloc of nations," another component of the Nazi International emerges, one which will be developed later in this chapter and in part two: the creation of a "Third Position" between the two likely postwar power centers of the United States and the Soviet Union.

4. Perón's "Third Position": Its International Geopolitical Implications

Indeed, Juan Perón began discussing the idea of what he called a "Third Position" between the far right's capitalism, and the far left's Communism, with his future foreign minister as early as 1947. So committed to this vision was Perón that he and his intelligence chief Rodolfo Freude invited the pro-Nazi sympathizer and Belgian "Rexist"²¹ Daye to meet with Perón personally after the latter had

overtly assumed power in Argentina. Both Perón and Freude were impressed with Daye's own attempts to cultivate such political views among his own contacts in Argentina and Europe,

and were particularly interested in (Daye's) group's objective of creating "a movement to unite all those in the world who do not support either of the two formulas offered to the masses: American democratic capitalism, which declares itself the champion of freedom and the defender of private property, and Bolshevik Russian Communism, the destroyer of private capitalism but also the destroyer of all individual freedom."²²

As will be seen in part two, this is a view with powerful geopolitical implications, for it will be found in many other instances in the postwar world where there was a palpable Nazi influence on various governments and political movements.

5. The Argentine Declaration of War on Germany, and Perón's Hidden Purpose

Allied pressure on Argentina to enter the war on the Allied side continued, and increased, from 1942 onward, and particularly so after the Colonels' Coup of 1943. Finally, in March 1945, Argentina "relented" to pressure and declared war on Germany, a little over a month before Germany's two surrenders on May 7 and May 8, 1945. But as Perón admitted later,

This false declaration of war had a clear purpose: "We hadn't lost contact with Germany, despite the break in diplomatic relations," Perón would say in 1967. "Things being so we received an unusual request. Even though it may seem contradictory at first, Germany benefits from our declaration of war: if Argentina becomes a belligerent country, it has the right to enter Germany when the end arrives; this means that our planes and ships would be in a position to render a great service. At that point we had the commercial planes of the FAMA line (Argentine Merchant Air Fleet) and the ships we had

bought from Italy during the war. That is how a great number of people were able to come to Argentina.”²³

With Argentina’s declaration of “war,” a declaration that reveals Perón’s very easy redefinition of war itself, Argentina’s role in the Nazi ratlines was secure, as was Perón’s own plans for it.

Bormann must have been delighted.

Nor is this a glib nor offhand comment, for it provides yet *another* possible route and alternative to the Hydrick scenario, for Argentine planes and ships could enter not only any Nazi occupied territory – such as Norway – with impunity, or Nazi-friendly Nationalist Spain, but under the Argentine flag, ferry Nazis and anything they wished under the security of being allied to the United States, Great Britain, and the Soviet Union! Argentina’s prospective role as a laundering point for Nazi treasure and a safe-haven for fleeing Nazis and their puppet allies, hinted at in the conversations between Goyeneche and Von Ribbentropp, was now about to pay both Juan Perón and the Nazi International, and Martin Bormann himself, big dividends.²⁴

B. The Ratlines and Argentina’s Role

1. The Ustashi-Vatican Dress Rehearsal

The “dress rehearsal” for Perón’s end of the ratlines and his clout with the Vatican is evident in the fact that, in 1946, Perón and Giovanni Cardinal Montini began secret negotiations to form a ratline for fleeing Italians and other groups,²⁵ the most notorious of which was the Nazi puppet Ustashi regime of Croatia. After the German invasion of Yugoslavia in 1941, the Third Reich carved Croatia out of the country and installed a Nazi friendly government.

If the German Nazis with their godless ideology and their gas chambers industrialized the business of genocide, the wartime Ustasha regime in Croatia was led by deeply Catholic men who employed medieval methods to conduct their programme of extermination. Mass shootings, clubbing and decapitation were the methods by which they pursued their aim of a racially pure

and 100 per cent Catholic state. By the end of the war some 700,000 people had perished in the Ustasha death camps at Jasenovac and elsewhere. The regime's fury was directed primarily against the Orthodox Serb population, but Jews and Gypsies were also included in the death roll.²⁶

The leader of this monstrous state was Ante Pavelic, "the Poglavnik, or Führer, of an independent Croatia."²⁷ While the Vatican danced around the genocide in Nazi Germany, "the Roman Catholic Church in Croatia became an ardent supporter of Pavelic's crimes,"²⁸ which included a race law promulgated in Zagreb that required not only that Jews wear an armband with the Star of David, but that Orthodox Serbs wear a blue armband designating them as Eastern Orthodox Catholic, rather than Roman Catholic, Christians.²⁹

The degree and ferocity of the Ustashi regime's atrocities appalled even the Nazis!

By August 1941, the office of General Edmund Glaise von Hortenau, the German army representative in Croatia, reported to Berlin that 200,000 Serbs had "fallen as victims of animal instincts whipped up by Ustasha leaders."

On 17 February 1942 Himmler received a detailed report on the "atrocities carried out by Ustasha units in Croatia against the Orthodox population." His agents told Himmler that the Ustashi committed their deeds "in a bestial manner not only against males of conscript age but especially against helpless old people, women and children. The number of the Orthodox that the Croatians have massacred and sadistically tortured to death is about 300,000."³⁰

Of course, the Nazi horror at all this carnage was hardly altruistic, as their concerns were more to maintain good relations with their Allies Romania and Bulgaria, both predominantly Orthodox countries.

Whatever Nazi Germany's real motivations were, it nonetheless demanded that Pavelic remove the most brutal of these executioners

from office, and there is evidence that suggests that the first ratlines from Europe to Argentina began as a result of this governmental crisis in Zagreb, since Pavelic utilized his friendship with Perón to purchase Argentine passports for his henchmen.³¹ As the war drew near its inevitable end, Pavelic transferred enormous sums to the Vatican and Switzerland for safe-keeping, to fund his Ustashi regime in exile in the pro-Nazi, and definitely Catholic, Argentina.³² Aiding and abetting this transfer of plundered Usashi treasure and murderers was Bishop Alois Hudal, longtime supporter of Pavelic's regime, who was also involved on the Vatican end of smuggling Nazis to Argentina as well.³³

2. *The Three Argentine Ratline Routes*

Direct German support for Perón finally came, strangely enough – or perhaps not so strangely after all, given all that has been reviewed thus far – *after* the war's end, in 1945-46, when Rodolfo Freude's father Ludwig, "a long-time personal friend of Perón with proven Nazi links, had channeled large contributions from Argentina's German business community into Perón's 1945-1946 presidential campaign, seeming to confirm the rumours that the colonel was in the pay of the Nazis."³⁴ By now it should be evident that when one says "German business interests" at this period of history, one says "Bormann" as well. Even Goñi, who as was seen does *not* subscribe to the theory of Bormann's postwar survival and presence in Argentina, had to mention that an American counterintelligence report from the period stated that "Ludwig Freude was 'financing Nazi resistance throughout the world.'" Moreover, notes Goñi, "rumours abounded that Hitler's deputy Martin Bormann was in hiding in Argentina and working with Freude."³⁵

So close was the relationship between Perón and his spy-master Freude that, when a momentary coup against Perón's puppet Edelmiro Farrell – no relation! – landed Vice President Perón in jail, it was Rodolfo Freude, and a convenient uprising of Perón supporters, that toppled the coup and propelled Perón to his 1946 election victory.³⁶

Once in full power, Perón established three separate routes for his ratlines:

- 1) the northern route via Denmark, Sweden, and Norway;³⁷
- 2) the Swiss route through Switzerland, a route no doubt effected by the personal visit of Evita Perón to Madrid, where she may have had contact with SS Colonel Otto Skorzeny;³⁸ and,
- 3) the southern route, via ships departed from Genoa, Italy, with Vatican diplomatic passports and false identities provided by the Archbishop of Genoa, Giuseppi Cardinal Siri.³⁹

Perón's own objective in creating these ratlines was to recruit technicians for his ambitious program of aeronautics and the development of modern jet fighters for Argentina's air force. Indeed, some of his first recruits were the brilliant pro-Nazi French jet designer Emile Dewoitine and Germany's equally capable Kurt Tank, an engineer for Focke-Wulfe, whom we will encounter briefly again in part three.

3. Bormann and Perón's Joint Bank Accounts and Their Implications

Hovering over all this activity is, of course, the shadow of Martin Bormann, and the possibility that he did escape, along with his plunder, from Europe.

But is there any *evidence* that this in fact occurred?

Oddly enough, there is, and it comes from a rare postwar document of Argentina's *Central de Inteligencia*. It is a bank account statement of a joint account held by Perón and Bormann, listed by national currencies.

JUAN DOMINGO PERÓN SOCIA, hace entrega al
Vice Fidejuss MARTIN BORMANN, la cuarta parte de los siguientes bienes:

**Central de Inteligencia
MARTIN BORMANN**

COPIA F.I.E.	En marcos oro	107.692.400,=
	En dólares	17.376.386,=
	En libras esterlinas	4.632.500,=
	En francos suizos	24.976.442,=
	En florines holandeses	8.379.030,=
	En francos belgas	17.280.909,=
	En francos franceses	54.968.000,=
	En platino Kg.	87,=
	En oro Kg.	2.511,=
	En Diamantes y Brillantes Kilates	4.638,=

 Rdo. Pedro EGIDIO ESPARZA
 JEFE ACCIDENTAL A.I.C.A.

Bormann's and Perón's Joint Bank Account Statement

Just what Bormann and Perón did with all this money – an enormous sum of dollars, Swiss, Belgian, and French francs, Dutch florins, and several kilograms of gold, platinum, and diamonds – will be suggested in part three.

With this review, however, we have concluded our survey of the background of the Nazi International. It is time, then, to see what their actual postwar political plans and activities were.

¹ Uki Goñi, *The Real ODESSA: How Perón Brought the Nazi War Criminals to Argentina*, Revised Edition (London: Granta Books, 2002), p. 108.

² Goñi, *The Real ODESSA*, p. xxi.

³ Cited in Goñi, *The Real ODESSA*, p. 100.

⁴ *Ibid.*, p. 3.

⁵ Goñi, *The Real ODESSA*, p. 2.

⁶ *Ibid.*

⁷ *Ibid.*, p. 3.

⁸ *Ibid.*

⁹ Ibid.

¹⁰ Goñi, *The Real ODESSA*, p. 7. The mention of Gottfried Sandstede in this respect may or may not be significant. Approximately two years before writing this book, I was contacted by a fellow researcher in this field who related to me that a colleague of his had been to a business party of prominent German businessmen in Washington, D.C. At the party the last name of Sandstede came up in connection with the Nazi Bell project, and in connection to some of Sandstede's family apparently living in the United States. I have been as yet unable to verify any connection.

¹¹ Ibid., p. 8.

¹² Ibid.

¹³ Goñi, *The Real ODESSA*, pp. 8-9, emphasis added.

¹⁴ Goñi, *The Real ODESSA*, p. 10, emphasis added.

¹⁵ See my *Reich of the Black Sun*, pp. 99-116.

¹⁶ Goñi, *The Real ODESSA*, p. 13.

¹⁷ Ibid., p. 14.

¹⁸ Ibid.

¹⁹ Ibid., p. 15.

²⁰ Goñi, *The Real ODESSA*, p. 16.

²¹ Belgian Rexism was Belgium's equivalent of Croatia's Ustashi, Spain's Falangists, Italy's Fascists, and, of course, Germany's Nazis. It was one of the many "exported versions" of Nazism inculcated deliberately by the Nazis in their occupied territories in Europe.

²² Goñi, *The Real ODESSA*, p. 170.

²³ Goñi, *The Real ODESSA*, p. 24.

²⁴ For the role of Argentina as a laundering point for Nazi plunder, see Goñi, *The Real ODESSA*, pp. 46, 58. It should be stressed, again, that Goñi himself does *not* subscribe to Bormann's survival nor therefore to his postwar presence in Argentina.

²⁵ Ibid., pp. 99, 248, 327-330.

²⁶ Ibid., p. 200.

²⁷ Ibid., pp. 200-201.

²⁸ Ibid., p. 201.

²⁹ Goñi, *The Real ODESSA*, p. 201.

³⁰ *Ibid.*, p. 202.

³¹ *Ibid.*, p. 219.

³² *Ibid.*, p. 210.

³³ Goñi, *The Real ODESSA*, p. 231. Hudal's role in this grizzly activity is also recounted at length in John Loftus' *Unholy Trinity*.

³⁴ *Ibid.*, p. 102.

³⁵ *Ibid.*, p. 108, citing Dispatch 1142, 9 November 1945, NARA, RG 59, Box 6746; US embassy in Madrid, Note 1742, 7 March 1946,, RG 59, Box 6747; and Dispatch 1628, 15 February 1946, NARA, RG 84, Box 84, File 820.02.

³⁶ *Ibid.*, pp. 105-106.

³⁷ Goñi, *The Real ODESSA*, p. 128.

³⁸ *Ibid.*, p. 136.

³⁹ *Ibid.*, pp. 127, 212, 235. Cardinal Siri also figures in the post-Vatican Two rumors that began to circulate among Catholic traditionalists that the conservative Siri had been elected an anti-pope in an alleged split within the conclave that elected the reformer and "modernist" Giovanni Cardinal Montini as Pope Paul VI.

Part Two: The Dialectical Manipulation of Conflict for Fun and Profit

*“...Dan Burros...once edited **Stormtrooper**, the American Nazi Party’s newsletter. Burros quit the group because he felt that (George Lincoln) Rockwell was too moderate. A former Nazi Party associate claimed that Burros enjoyed torturing dogs, including his own pet, Gas Chambers. Curiously, Burros’s name and address (along with Rockwell’s) were subsequently discovered in the notebook of Lee Harvey Oswald, the man accused of assassinating President John F. Kennedy.”*

Martin A. Lee,

The Beast Reawakens:

Fascism’s Resurgence from Hitler’s Spymasters to Today’s Neo-Nazi Groups and Right-Wing Extremists,
p. 163.

✠ 7 ✠

“Born-Again Nazis Find Allah:” Wartime and Postwar Nazi Collaboration with Arab States and Radical Islam

“The genesis of the cooperation between militant Islam and the extreme right can be traced back to the early years of the Third Reich.”
George Michael¹

The first, and last, time a German *Lufthansa* airliner was hijacked, few people really noticed what had happened, and even fewer people noticed what it meant.

In October of 1977, *Lufthansa* flight 181 flying from Palma de Mallorca to Frankfurt was hijacked by four Muslim terrorists who were members of the so-called Popular Front for the Liberation of Palestine. After a zig-zag course from Rome to Bahrain, Dubai, and so on, the hijackers eventually put the plane down in Mogadishu, Somalia. The hijackers were demanding the release of members of the Red Army Faction, another terrorist group, being held in West German prisons, and fifteen million American dollars. After the hijackers shot the German pilot in the head in front of the 86 passengers and threatened to blow up the plane if their demands were not met, things really began to go wrong...

...for the hijackers.

Unbeknownst to them, West German Chancellor Helmut Schmidt had secretly authorized West Germany's elite commando unit, the GSG-9, in conjunction with Britain's SAS, to storm the plane in

Mogadishu, and take out the hijackers. This they did with customary German efficiency, leaving three of the four hijackers dead, the other one in custody, and only one injury to a passenger and a flight crew member. Germany's message was clear: Mess with us, and we will hunt you down, wherever you are, and kill you. Chancellor Schmidt was widely praised in the German and world media for his decision and his government's stance.

But what people neglected to notice were the implications of the event:

Germany had deployed an elite military commando team outside of Germany, over a thousand miles away, on a moment's notice, executed a nearly flawless military operation in conjunction with the British, and it was all over almost before the hijackers had even known it was happening. It was the first time since World War Two that Germany had deployed any unit of its military outside its borders in active combat operations. It was also the first, but definitely not the last, time Germany would deploy its elite and highly secretive GSG-9 unit to rescue a delicate situation. And it demonstrated Germany's ability, and willingness, to project coordinated and deadly force at significant distances from her borders.

A. Nazi Germany's Penetration of the Muslim World

The incident was ironic in another sense, for it was one and the same Germany that had helped spawn *and train* so many of the nascent Muslim terrorist groups to begin with:

The genesis of the cooperation between militant Islam and the extreme right can be traced back to the early years of the Third Reich. During World War II, much of the Islamic world sympathized with the Axis alliance. Members of the Muslim Brotherhood would often say prayers for an Axis victory during their meetings. Moreover, some Muslims went so far as to fantasize over putative Islamic affinities of fascist leaders. For example, rumors abounded that Benito Mussolini was an Egyptian Muslim whose real name was Musa Nilil (Moses of the

Nile) and that Adolf Hitler too had secretly converted to Islam and bore the name Hayder, or “the brave one.”²

Notwithstanding these Muslim fantasies, Nazi Germany was initially slow to respond to Arab world entreaties.

After the promulgation of the Nuremberg Race Laws in 1936 which denied German citizenship status to Jews, the Nazi Reich received telegrams of support from throughout the Muslim world. The Third Reich’s interest in the Muslim world, however, would not begin until 1937 “with the publication of a report by the British Royal Commission, which explicitly recommended for the first time the partition of Palestine into separate Jewish and Arab states.”³ This prompted the German Foreign Ministry, which feared a Jewish state could become a base of operation for “international Jewry” along a similar basis as the Vatican City State, to examine ways of increasing support for the purpose of strengthening the Muslim world “as a counterweight against such a possible increase in power for world Jewry.”⁴ These methods included overt diplomatic overtures to more covert support for radical Islamic groups. Attention was paid to three countries in particular on the peripheries of the British Empire, strategically positioned to threaten sensitive British interests: Iraq, Iran, and Afghanistan.

1. Iraq

In some respects, Iraq constitutes the significant exception to the above pattern, for as I wrote in a previous book, *The Cosmic War*, German interest in the country began long before the Nazi Party took power. It is worth recounting what I said in that book here, in the new context of an examination of Nazi geopolitics in the Arab world:

Nazi interest in that country, then under strong British influence, dates back to the 1920s when the National Socialist party was still in its infancy. Not surprisingly, one finds the character of Detlef Schmude - a main player in the Nazi party’s secret society backer, the infamous *Thule Gesellschaft*, a

member as well in Von Liebenfels' Order of the New Templars (ONT) and an editor of the Thule Society's magazine *Ostara* – settling in Tabriz, in neighboring Persia. There he based his next few years' search for the "Hidden Masters." Someone of Schmude's importance and position within these groups suggests that he was the point man for gathering facts and information for them.

Then, in 1939 Admiral Wilhelm Canaris' *Abwehrabteilung*, Germany's military intelligence, dispatched Dr. Paul Leverkühn to the Middle East to cultivate allies among the Muslim populations under British rule or influence. His headquarters was also Tabriz, in Persia. But most interestingly, his most highly-placed recruit was none other than pro-Nazi Iraqi Prime Minister Rashid Ali, overthrown two years later by the British invasion of Iraq.

Canaris' network of *Abwehr* agents inside of Iraq was taken over by Himmler in 1944, after Canaris' implication in the Bomb Plot against Hitler in July of that year. Strangely enough, Himmler placed these agents under the control of none other than Baron Rudolf Von Sebottendorff, one of the principal founders of the *Thule Gesellschaft* to begin with and, like Schmude, a member of Von Liebenfels' Order of the New Templars! This implies that the *real* basis of Nazi networks in Iraq was grounded in the secret society network in the region, perhaps initiated by Schmude.

Yet another connection that must be mentioned is "Himmler's Rasputin," Karl Maria Willigut, a.k.a. Weisthor. In 1940 Willigut brought several archaeological discoveries that indicated man's presence in Iraq's Irbil province as far back as 10,000 B.C.

What happened to this Thule-SS network in Iraq after 1945 no one knows, however, it is interesting to note that Von Sebottendorff's body was found floating in the Bosphorus in Istanbul in 1945, after the war's end.⁵

As indicated, Nazi interest in Iraq stemmed in part from the covert and hidden occult influences at work in the secret societies that

midwifed the Nazi Party into existence, influences that later extended into the upper echelons of Himmler's SS.

But here it is important to note the *political* aspect of German involvement, for with German support, Rashid Ali staged his now famous coup. It was an act that directly threatened Britain's oil lifeline. Britain had to respond, and did so with an invasion that topped the regime. The British invasion did not, however, succeed in rolling up the Nazi espionage network, for that was based in Iran, as was seen.

The Iraqi coup was aided by the Grand Mufti of Jerusalem, who in 1939 was in Baghdad, meeting with the Committee of Free Arabs. There he discussed the plans for the coup with the group of colonels leading the committee. The Mufti was at it again in 1940 when he was in Berlin, signing an "Axis-Arab Manifesto of Liberation," in which both Fascist dictators expressed their "strong support for an independent, united Arab nation."⁶ What emerges from this is a pattern of Nazi and German support for and exploitation of Arab and Muslim aspirations against the "imperialism of oil," i.e., Britain and the United States. It is a pattern to pay attention to, for it will figure prominently not only in the policies and agenda of the postwar Nazi International but to a certain extent in the geopolitics of West Germany as well.

2. Iran

Iran played its own peculiar role in Nazi-Muslim contacts. In Persia, a nationalist general, Shah Reza Pahlavi, "who seized power in 1925, was an admirer of Adolf Hitler's racial policies and even went so far as to rename his country Iran, which translates into Aryan in Persian."⁷ During the Shah's reign until overthrown by British and American troops in 1941,⁸ the Grand Mufti of Jerusalem briefly took refuge in the country, as will be seen below.

3. Afghanistan

Afghanistan was another country to which Nazi Germany made serious diplomatic advances throughout the 1930s. These, as

elsewhere in the Muslim world, were successful and Germany succeeded in establishing very cordial relations with the Afghani government. So good were relations that the Nazis “even attempted to establish a political alliance with Mullah Mirza Ali Khan, who, along with his Waziri mujahedeen, resisted British rule of the Northwestern Province of Afghanistan from 1937 to 1947.”⁹ Nazi envoys successfully contacted Islamic guerillas in the British zone of Sarhad, bringing with them “a letter of support from Adolf Hitler.”¹⁰ This time, however, the embassy was ambushed by the British and Afghani border police. The king, whatever his pro-Nazi sympathies might have been, was well aware of what had happened to Iraq and Iran, and decided to expel all German and Italian diplomats from his country.¹¹

B. The Grand Mufti of Jerusalem, Al-Husseini, and Nazism

As has been seen, the Grand Mufti of Jerusalem, Haj Amin Al-Husseini, played a prominent role in Nazi plans for the region. Having signed the Axis-Arab Manifesto of Liberation in Berlin in 1940, the Grand Mufti once again made his way back to the Middle East, first headquartering himself in Baghdad until the British coup overthrew the pro-Nazi government, forcing Al-Husseini to flee to Nazi-friendly Iran, until again forced to flee by the arrival of British and American troops and the installation of a pro-Allied puppet government in Tehran. Al-Husseini made his way back to the one country and city in which he knew he would be welcome, and where he would remain until the war's end: Nazi Germany, and Berlin. There, among other “activities” in aid of the Nazi-radical Muslim cause, he helped form the Arab League in 1944.¹² But his other “activities” are worth mentioning in their own right.

According to researcher George Michael, the Grand Mufti has his own hands bloody in the Holocaust, for he played a significant role in discouraging the Nazi regime and the pro-Nazi governments of Romania, Hungary, and Bulgaria, from allowing Jewish emigration to Palestine.¹³ More importantly, Al-Husseini, while still resident in Jerusalem, received a special envoy from Nazi Germany in 1937, one of whose members was Adolf Eichmann. The purpose of the

special embassy to Al-Husseini was to discuss the possibility of Jewish emigration to Palestine. Husseini, of course, discouraged this.¹⁴

1. Hitler and Husseini at Tea

According to Michael, however, Husseini's access to the Nazi regime while he was in Berlin may have been so extensive that he even knew Hitler personally. Michael, whose research contacts included one Ahmed Huber, "a Swiss national depicted as a liaison between the contemporary extreme right and militant Islam,"¹⁵ relates the following account of a meeting between Hitler and the Grand Mufti that Huber alleged took place between the two leaders. According to Huber, the Grand Mufti told him of many meetings with Hitler:

He told me a fantastic story. On one night in December 1941, after the big victories of Germany over the Soviet Union, he had a long talk with Hitler about architecture, culture, the music of Richard Wagner, and so on. Hitler started talking about race theory and anti-Semitism and the Grand Mufti asked Hitler, "Did you ever think, Mr. Chancellor, that your race theory comes out of Judaism? It comes out of the Old Testament." And Hitler was very astonished by that. The Grand Mufti knew the Bible very well. He said, "All your ideas, the doctrine of the Nazi Party are in the Old Testament. The chosen people of God are not the chosen people, but the chosen race and that blood carries the soul. And this chosen race must keep its blood pure. It must not mix its blood with non-Jews; the foreigners, the subhuman beasts called the goyim, are inferior to the Jewish master race. The genocide order of God in the fifth book of Moses and in the book of Joshua. The race laws of Ezra and Ishmael. All of these things are in the Old Testament." Hitler was absolutely astonished and the Mufti told him (further), "You have not high esteem for the Africans, for Black people. And also this comes from the Old Testament in the first book of Moses, the Black race is doomed, considered by God to eternal slavery. It's the

famous curse by God on Ham, one of the three sons of the prophet Noah.”¹⁶

Besides giving Hitler Bible lessons on the mediaeval barbarism of the Old Testament parallels to his racial policies, the Mufti was also giving more material assistance to the Nazi cause as well.

2. *The First Suicide Squads and the Muslim Waffen SS*

Among the more active material assistance the Grand Mufti gave to Hitler was his active recruitment among Bosnian Muslims for volunteer soldiers for the Muslim Waffen SS *Handschar* division.¹⁷ Husseini also made pro-Axis broadcasts to the Arab world from Nazi Germany, and wrote a book, *Islam and the Jews*, a “motivational” treatise designed to incite Muslim hatred of Jews – and, as it turned out, Orthodox Christian Serbs – and motivate Muslim volunteers to assist in the Nazi slaughter.¹⁸ For his efforts, the Nazi regime made him the Supreme Sheikh-ul Islam, the supreme “chaplain” for Nazi Germany’s Waffen-SS Muslim legions.¹⁹ If the Nazi regime’s evaluation is any indicator, Al-Husseini was a definite asset to “the cause.”

Indeed, in one sense, the Grand Mufti succeeded in opening the floodgates of Muslim manpower to the Axis, for as late as 1945 units of volunteer Muslims were raised from Chechnya and other regions far behind the front lines in the Soviet Union, and were “organized into nineteen independent Islamic combat battalions and twenty-four infantry companies in the Wehrmacht.” Furthermore, Muslim Turks and Tartars were organized into “a Waffen-SS division known as the Osturkisches Waffenverband (East Turkish Armed League) and SS-Waffengruppe ‘Turkestan’ (SS Armed Turkestan Group).”²⁰ Some of these units operated behind Soviet lines as anti-Communist partisan groups, while several Muslim units participated in crushing the Jewish uprising in the Warsaw ghetto.²¹

The Grand Mufti certainly delivered not only manpower but experience for such activities, for he is also credited for helping to organize long before the war “the first modern fedayeen...suicide

squads, which primarily targeted moderate Arabs who refused to support his agenda.”²²

3. Cousin Yasser Arafat

Not surprisingly, then, the Grand Mufti appears to have figured in the Nazis’ postwar calculations. Remaining in Germany until just three days before Hitler’s alleged suicide, the SS contacted the Mufti and offered him an airplane by which to escape from Switzerland. Al-Husseini refused, apparently preferring to make his way to the neutral country by means of a car which he had purchased for the purpose. The SS hoped that Al-Husseini “would eventually make his way to North Africa, where he had established spy networks that were still extant.”²³ In point of fact, the Grand Mufti did indeed eventually end up in Egypt, where he had a great influence on emerging Arab leaders, and no doubt also helped organize radical Islamic guerilla and suicide units, for among those he influenced was his distant cousin, Yasser Arafat, founder of the Palestine Liberation Organization. Additionally, there is evidence that the Mufti also was directly involved in the organization of Fatah, the PLO’s militant and terrorist arm.²⁴

Just how Al-Husseini was able to do all this without significant financial support is a moot point, for as has been seen, Bormann’s emerging Nazi International not only had money, but had lots of it. The fact that Al-Husseini was offered direct SS assistance as the Reich collapsed - and with the mad scramble of Nazis trying to flee the country and acquire their own vehicles and airplanes, already in scarce supply - is an indicator of just how highly ranked in the scheme of Nazi priorities for the postwar world he really was. Needless to say, the Mufti also helped organize ratlines for Nazis who fled to the Middle East, with significant postwar repercussions as will be seen momentarily.²⁵

C. The “Third Position” and the Egyptian Venture: Skorzeny, Schacht, Voss, and Nasser

All this is a powerful indicator that behind the crescent of radical Islam in the postwar world there might loom an even more sinister symbol of terror and murder, the swastika. But this presence is more than mere conjecture based upon probable shadowy connections between the Nazi International and Al-Husseini. Nazi participation was sought by postwar Arab leaders, was given by the Nazis themselves, and often with the quiet but very direct support of the West German government itself.

Egypt's postwar leaders and their collaboration with well-known postwar Nazis is a significant case in point, and in it, one may see the outlines of the Nazi International's postwar policies and politics at work. Egypt was, in fact, the one country that perhaps was the most deeply influenced by the Nazi regime,²⁶ for as Field Marshal Rommel's Afrika Korps drove ever deeper and closer to Alexandria and Cairo in early 1942, Egyptian Arab sympathies for an Axis victory were often openly expressed in British occupied Egypt. Even King Farouk was supportive of the Nazi cause in spite of his rule being propped up by the British.

Even with the war's end, "populist" Egyptian anti-Western sentiment against Farouk's rule had grown to such an extent that "both the U.S. and British governments decided that Farouk had to be replaced."²⁷ At this juncture, events once again took a very strange turn:

The CIA, under the influence of John Foster Dulles, selected Egyptian general Muhammad Naguib to lead a new Egyptian government. On July 22, 1952, with the help of the CIA, Naguib sent the army into the streets of Cairo and Alexandria and established himself as the commander in chief of military forces. Although Naguib was the titular head of state, unbeknown to the CIA, the real power ultimately rested with Lieutenant Colonel Gamal Abdel Nasser, who soon assumed the position of president. This coup was also significant because it opened the door for numerous Nazis to take prominent positions in the Egyptian government.²⁸

This calls for some commentary.

As is known by now, the reality of the CIA's "Soviet Desk" at that period of history was that it was being run on a practical level and in terms of its human on-the-ground assets in Eastern Europe by a group of Nazis, still under the command of the wartime general in charge of German military intelligence on the Eastern Front, Reinhard Gehlen. Gehlen had negotiated this arrangement with none other than John Foster Dulles' brother, Allen Dulles. Thus, one may reasonably conjecture that behind the American support for the coup against King Farouk there lurks probable consultation between the two Dulles brothers - John Foster, at the time President Eisenhower's Secretary of State, and Allen, over at the CIA - in who best to lead it.

But it has often been pointed out that the value of Gehlen's intelligence regarding foreign attitudes and intentions toward the U.S.A. was often specious at best, for Gehlen's *intentional* overestimation of Soviet military capabilities and intentions played no small part in the spread and enduring intensity of the early Cold War. Little has been said, however, on why Gehlen might have deliberately wished to influence postwar American military and geopolitical policy by such overestimations. But it does make sense in the light of a presumptive postwar Nazi intention to exacerbate postwar East-West tensions in order to play one side off against the other, enhancing Germany's position in the process, and exploiting conflicts in other nations that such tensions would inevitably create. More on this in the next chapter.

Such appears to be the case in respect to the days immediately following Nasser's CIA-sponsored coup, for suddenly, America's interests seemed to fall off Nasser's radar screen, only to be replaced by someone else's. George Michael notes that "not long after the war, many German military officers and Nazi party officials were granted sanctuary in Middle Eastern countries, most notably Egypt and Syria, where they helped develop the militaries and intelligences agencies of those countries."²⁹ One of these officers who found sanctuary in Egypt was the unrepentantly Nazi general, Otto Remer.³⁰ Remer's presence is significant, for not only was he the founder of the thinly-disguised neo-Nazi Socialist Reich Party in

postwar West Germany, he was also the very general who crushed the coup attempt against Adolf Hitler in July of 1944 by maintaining Nazi control over the military units in Berlin.

It was with General Remer's help – and that of former SS commando Otto Skorzeny – that Nasser developed an Egyptian support base for anti-western guerillas in Tunisia, Morocco, and Algeria as well as for insurgencies in Aden and Kenya.³¹ In other words, one postwar policy and agenda of the Nazi International is now in full view: the exploitation of anti-imperialist and nationalist insurgencies in the colonial empires of France and Britain. General Remer was the contact point between Nasser's Egypt and these guerillas, for he arranged the trafficking of arms and training – often with former Muslim and German SS veterans – for these guerilla movements.³²

1. Wilhelm Voss and Otto Skorzeny in Gamal Abdul Nasser's Egypt

Skorzeny himself had arrived in Egypt in the early 1950s to lend his military expertise in the training of the Egyptian Army and Muslim and other “anti-imperialist” guerilla units. There he quickly formed a triumvirate with Nasser and the Grand Mufti in order to further their mutual goals.³³ Not surprisingly, a young Yasser Arafat met the famous SS commando-colonel while being trained in “unconventional warfare” by the SS, and developed a friendship that “would reportedly last for many years.”³⁴

If it were merely Skorzeny and Remer who offered financial assistance, weapons, and training to Nasser, one could reasonably reject the argument that this venture represented a coordinated effort by Bormann's postwar Nazi International. But when the presence of other prominent Nazis in Nasser's Egypt is also weighed in the balance, the probability of that interpretation quickly shrinks, and the probability of a coordinated covert effort by the postwar Nazi International increases proportionally. The key is Skorzeny himself:

Skorzeny's principal responsibility was to train thousands of Egyptian commandos in guerilla and desert warfare.

Furthermore, he organized and planned the initial forays of the early Palestinian terrorists into Israel and the Gaza Strip around 1953-1954. An Arab Foreign legion was created, whose nucleus consisted of 400 former Nazi veterans who were recruited by the Arab League agents in Germany. Finally, Skorzeny sought to protect German scientists, technicians, and engineers who were recruited to work on Egypt's special military program.³⁵

Skorzeny coordinated all this military activity with yet another German military advisor in Nasser's Egypt, SS Lieutenant General Wilhelm Farmbacher.³⁶ But what were all these German scientists, technicians, and engineers doing in Egypt to begin with?

The clue is found in the presence in Egypt of none other than Dr. Wilhelm Voss, who had been sent to Egypt personally by West German Chancellor Konrad Adenauer. For readers of my book *Reich of the Black Sun*, however, Dr. Voss will ring a bell, for he was in fact the civilian liaison inside the engineering division of the Skoda Munitions work in Pilsen, Czechoslovakia, and it is thanks to Voss's revelations to British journalist Tom Agoston that the existence of SS *Obergruppenführer* Hans Kammler's secret weapons think tank inside of the Skoda works was first publicly revealed.³⁷ Voss was in Egypt coordinating the secretive West German technical assistance being given to Nasser to develop his own missiles capable of targeting Israel and other neighbors, but he was also coordinating West Germany's economic assistance and trade with the new Nasser regime. Indeed, his influence in the early years of Nasser's Egypt was so sweeping that he was in fact "the architect of the Egyptian economy in the early postwar years."³⁸ But there's more, for according to George Michael and other researchers, it was Voss who, "working with Reinhard Gehlen, Skorzeny, and Hjamlar Schact...increased West Germany's trade with Egypt."³⁹ Not only was *Schacht* present, but a former member of Nazi Propaganda minister Josef Göbbhels' Propaganda Ministry was represented in the form of Johann Von Leers, a former assistant to Göbbhels himself!⁴⁰ Once in Egypt, Von Leers helped translate *Mein Kampf* into Arabic – one only need recall Saddam Hussein's copy in this

regard – but also other Nazi “classics,” such as the notorious *Protocols of the Learned Elders of Zion*. Additionally, Von Leers assisted Nasser’s regime in churning out an endless stream of torrid anti-western and anti-Israeli propaganda.

There are only two real explanations for this sudden appearance of so many high ranking and well-connected Nazis in Nasser’s Egypt, one is “mere coincidence,” and the other is that it was by deliberate design. Obviously, the probability is that it was by deliberate design, for pause and consider very carefully what it means: scarcely seven years after the end of the Second World War, and only three years after the grant of sovereignty by the Western Allies – France, Great Britain, and the United States – to West Germany, we have present in Egypt the following people:

- 1) The Wehrmacht general who crushed the July 1944 coup attempt against Hitler, and founder of the postwar neo-Nazi Socialist Reich Party in West Germany, General Otto Remer;
- 2) SS Colonel and Hitler’s favorite commando, Otto Skorzeny;
- 3) The former president of Hitler’s *Reichsbank*, Dr. Hjalmar Horace Greeley Schacht;
- 4) The former civilian liaison to SS General Hans Kammler’s secret weapons think tank inside the Skoda Works at Pilsen, Czechoslovakia, Dr. Wilhelm Voss;
- 5) A former member of the Nazi propaganda ministry and a personal assistant to Dr. Josef Göbbels himself, Johann Von Leers!

The presence of so many people, including Hjalmar Schacht, Reinhard Gehlen, and SS Colonel Skorzeny, in this venture can hardly be accidental.

2. Schacht’s Little Deal: The Jeddah Agreement

Schacht’s activities in the Middle East also bear mentioning as well, for he – or his hidden masters – hardly restricted their economic vision to Egypt alone, for he was the major broker of the so-called “Jeddah Agreement” in 1954 between German industrial companies

and Saudi Arabia. Under the protocols of this agreement, Saudi Arabia “agreed to establish a fleet of supertankers – to be built in German shipyards – that would transport Saudi oil around the world.”⁴¹ And as if that were not enough to convince the most hardened skeptic that all these connections can hardly be coincidental, “the Greek magnate, Aristotle Onassis, was chosen to manage the shipping side of the arrangement.”⁴²

This deal, of course, directly threatened British and American oil interests in the region, for it threatened to end their own cartelization of the commodity and the Middle East’s oil field. With the aid of the CIA, they succeeded in blocking the agreement.⁴³ The very fact that the CIA was involved in this affair is an indicator that it was encountering very serious “blowback” in its early backing of the coup that brought Nasser into power in Egypt.

3. The Ultimate Geopolitical Goal: The “Third Position” Again

But what was the ultimate goal of all these maneuvers? Researcher George Michael puts it as succinctly as any, and in so doing, points out yet *another* connection to Nazi ideology and its worldwide agenda:

During this period, renascent Nazis saw the rise of Arab and Third World nationalism as an excellent opportunity to create a German-Islamic neutralist alliance that would extend from the heart of Europe to the South China Sea. This idea was consistent with the late Karl Haushofer’s (sic, et passim) policy of an alliance with the “Colored World.” Haushofer is generally regarded as responsible for popularizing “geopolitics.” One vision of this new extreme right foreign policy was to create – with the assistance of the grand mufti and the Arab League – a German-Egyptian-dominated power bloc that could resist both the United States and the Soviet Union.⁴⁴

In other words, behind the Nazi machinations in Egypt lies the much-older historical foreign policy of Germany and, by implication,

Prussia itself. This creation of a “Third Bloc” between the United States and Communist Russia was one of the major postwar goals of the Nazi International, for that bloc would inevitably have to be centered on Europe, and on Germany’s position as the still predominant European power. And as for (general) Karl Haushofer, he was, of course, Adolf Hitler’s geopolitical guru, and one of the salient influences on Hitler’s geopolitical views as expounded in *Mein Kampf*.

Needless to say, not all went according to the postwar *Nazi* plans for Egypt either, for under increasing pressure from the Soviet Union, Nasser went out of his way to alienate his West German allies by recognizing the government of East Germany. In response, West Germany retaliated by breaking relations with Egypt, and withdrawing its technical and economic support.⁴⁵

But even in these events, one may discern a palpable Nazi influence at work. As I noted in my previous book *The SS Brotherhood of the Bell*, the presence of General Reinhard Gehlen’s espionage network inside of Eastern Europe implies the possibility that this organization – the only intelligence organization with known connections both to the Eastern and Western blocs – may have played a role in the secret coordination of Russian and American space activities.⁴⁶ But to put it in this political context gives that possibility more significance, for as German foreign policy has consistently and historically played East and West off against each other, the postwar Nazi International, if it was to pursue a similar course of action, would have to have a presence in both blocs. Understandably, then, some postwar Nazis promoted closer cooperation with the Eastern bloc.

One of these was an old friend and associate of Otto Skorzeny – himself a proponent of a “westward” orientation - Dr. Fritz Grobba, who was Berlin’s ambassador to Iraq and to Saudi Arabia prior to the Nazi-supported coup that overthrew the British puppet government in Baghdad! Indeed, he and the Grand Mufti had both collaborated in this design.⁴⁷ But *after* the war, this “former” Nazi Middle Eastern ambassador, and convert to Islam,⁴⁸ wound up as “the director of Arab affairs at the Soviet Foreign Ministry in Moscow,”⁴⁹ and thus

was the Soviet point man in brokering the first arms deal between the Soviet Union and Nasser's Egypt! Not only that, there is also evidence that at the same time that as Skorzeny acted as the liaison between the Nazi International, the Adenauer government in Bonn, and Egypt, he also "is thought to have helped Nasser's alliance with the Soviet Union."⁵⁰

To put it as succinctly as possible, Nazis were behind the overthrow of King Farouk and the installation of Nasser, Nazis were behind the training of his intelligence agency and army, Nazis not only helped guide Egypt's economy, but they were also behind Nasser's alliance with the Soviet Union. Nor was this without immediate economic and geopolitical repercussions, for as is now known, with his Nazi-trained troops, Soviet weapons, and Nazi-manipulated new alliance with Moscow, Nasser seized the Suez Canal and successfully expelled the last vestiges of French and British power and influence in Egypt. It is perhaps significant, then, that Nasser eventually expelled the Soviets from Egypt, for if there was a hidden Nazi hand in the initial invitation, there may have been one in the expulsion as well.

a. An International Terrorists' Summit

In addition to direct postwar machinations in the various Middle Eastern nations, there was also an attempt to penetrate and coordinate postwar international terrorist activity as well:

The Black International, which operated under the name of the European New Order, held a summit at Barcelona on behalf of the Palestinians. The organization was composed of various Nazis and fascists from Nazi Germany, Vichy France, Franco's Spain, Salazar's Portugal, Mussolini's Italy, and the Greek colonels' military junta. The Spanish leader, General Francisco (sic) Franco, is believed to have endorsed the meeting. Two representatives from Fatah, the military arm of the PLO, attended the event. Reportedly, the delegates discussed raising money, organizing the arms traffic, and providing ex-Nazi military instructors to help train guerillas. A major endeavor was

to recruit Caucasians to augment Fatah's forces in the Middle East and also collaborate in acts of sabotage and terrorism in Europe. Several summits followed this event, including one held on September 16, 1972, barely ten days after Palestinian Black September terrorists killed eleven Israeli athletes at the Munich Olympics.⁵¹

In other words, the now familiar pattern of internationalizing Nazism around a solidly German core was again in evidence, in a deliberate effort to coordinate European and Middle Eastern terrorist activity.

b. The Neo-Nazi Connection to the Assassination of Pope John Paul II

These efforts knew no bounds. As is now known, many members of Licio Gelli's notorious P2-G Masonic lodge in Italy in the 1960s and 1970s had Fascist and Nazi connections, and Gelli himself, in a less-than-coincidental and ironic parallel to the postwar Nazi ratlines, fled Italy to avoid prosecution. He went, of course, to Argentina. And one of the most notorious of these postwar terrorists affiliated with a Nazi-sponsored secret society was Mehmet Ali Agca, the assassin who attempted to murder Pope John Paul II in cold blood during a papal appearance at the Vatican shortly into the latter's pontificate. Agca was a member of a Turkish secret society called "The Gray Wolves," a society founded by a former Turkish SS member and volunteer, Mehmet Kengerle.⁵²

c. Mohamar Qaddafi's "Perónism"

Nor were Turkey, Egypt, Palestine and Iraq the only centers of pre- and post-war Nazi attention. Mohamar Qaddafi's Libya, widely regarded during the 1970s and 1980s as a premier state sponsor of international terrorism, also had its own role. While there is no known direct connection between Qaddafi and postwar Neo-Nazism, it is peculiar that Qaddafi, who attempted to orchestrate his own international terrorist organization, did so in conjunction with his elaboration of a foreign policy that attempted to combine into a broad

coalition nations and groups seeking an alternative to the Western and Eastern blocs. Essentially, Qaddafi, who outlined his ideas in a treatise called *The Green Book*, attempted to combine “nationalism, anticapitalism, anti-communism, and anti-imperialism, into a populist ideology.”⁵³

He called his idea “Third Positionism.”

Shades of Juan Perón!

*d. The Historical Parallels and Geopolitical Implications of the
“Third Position:”*

As indicated in this and previous chapters, this “Third Position” was a major theme in the designs of the postwar Nazi International. And that very position itself is perhaps the indication of a hidden though very real German guiding hand on the international geopolitical stage in the postwar world, for that very position was a cardinal guiding principle of Prussian and German foreign policy, from the Prussia of Frederick the Great, through the Chancellorship of Otto Von Bismarck and later, the Weimar Republic, and finally of course, Adolf Hitler’s non-aggression pact with Joseph Stalin that secretly partitioned Poland and made World War Two Possible.

(1) Rapallo: The Pariahs Make a Deal

The modern roots of this sometimes hidden, sometimes open German-Russian collaboration begin, in fact, in the aftermath of World War One. In 1922, Weimar Germany and the Soviet Union, the two nations most effected and dislocated economically by World War One, and the two nations that were the least influential in great power politics in the face of the overwhelming Western military and economic superiority, were pariah nations. Not surprisingly, they decided to make common cause. Signing an agreement in 1922 at Rapallo, both nations agreed on mutually beneficial economic trade. But as a condition for such trade, German General Hans Von Seeckt insisted on a secret protocol to the treaty, and the newly installed Soviet regime, fresh from World War One and a grueling civil war, only too readily agreed.

Von Seeckt, as commander of the German army, was left under the terms of the Versailles treaty with a small standing army, no air force, and a navy only sufficient enough for a meager coastal defense of Germany. For a general in command of the army of a great power virtually surrounded by other great powers, this was, of course, an intolerable situation. Accordingly, Weimar Germany negotiated a secret protocol with the Soviet Union that would allow German military units to train with their Soviet counterparts on Russian soil, using all the weapons – tanks, aircraft, and heavy artillery – prohibited to Germany under the Versailles Treaty. In this way, Von Seeckt transformed the tiny German *Reichsheer* into a highly professional army whose soldiers, once the time was right, could be promoted and form the officer corps for a vastly expanded and highly competent German army – the Wehrmacht -when full rearmament became feasible. Many of these Germans and Russians who trained with each other in the Soviet Union during the 1920s such as Colonel General Heinz Guderian – inventor of the blitzkrieg and whose Second Panzer Army very nearly entered Moscow in 1941 – and Soviet Marshal Timoshenko, knew each other personally.

(2) Frederick the Great and the Partitions of Poland

But the historical roots of German foreign policy and *Ostpolitik* lie much deeper, reaching all the way back, as some have pointed out, to the Teutonic Knights and the ethnic relationship of Prussians – or Berussians – to Russians themselves. It has been a stormy relationship, to say the least. But the more immediate parallel to German and Russian cooperation – a parallel often noted by historians – are the three partitions of Poland between Prussia, Austria, and Russia, partitions readily agreed upon by Prussian king Frederick the Great and another German monarch, Tsaritsa Catherine the Great. As Prussian and Russian economic interests penetrated an already weakened Poland, the two monarchs, with Austrian complicity, simply agreed to annex the portions of the country that each wanted.

Frederick, whose *Ostpolitik* helped transform Prussia into a Great Power, and whose military reforms demonstrated Prussia's military

proress by fighting the superior forces of Austria and Russia to a standstill in the Seven Years' War, ended his reign with his country the dominant military power in central Europe. Frederick had introduced many of the traditions of the Teutonic Knights and most of the modern images associated with German military tradition – the parade step or “goosestep,” the ranking system, the ceremonial “bell tree” and so on – into the Prussian army.

When the Berlin wall came down and East and West Germany were reunited, the German government honored the Prussian king in a most traditional way, and almost no one in the world's major media outside Germany itself paid any attention at all...



Otto Skorzeny, Hitler's Favorite Commando



Skorzeny and Hitler



*General Otto Remer at the Time of the Foiled Coup Attempt
Against Hitler*

¹ George Michael, *The Enemy of My Enemy: The Alarming Convergence of Militant Islam and the Extreme Right*, (University Press of Kansas, 2006), p. 112.

² George Michael, *The Enemy of My Enemy: The Alarming Convergence of Militant Islam and the Extreme Right*, (University Press of Kansas, 2006), p. 112.

³ George Michael, *The Enemy of My Enemy: The Alarming Convergence of Militant Islam and the Extreme Right*, (University Press of Kansas, 2006), p. 113.

⁴ Ibid.

⁵ Joseph P. Farrell, *The Cosmic War: Interplanetary Warfare, Modern Physics, and Ancient Texts* (Adventures Unlimited Press, 2007), p. 419.

⁶ George Michael, *The Enemy of My Enemy: The Alarming Convergence of Militant Islam and the Extreme Right*, (University Press of Kansas, 2006), p. 114.

⁷ Ibid., p. 113.

⁸ Persia, or Iran, was divided between the Soviets and British into two zones of influence and occupied during the war to prevent precisely an Axis penetration into the country and a potential alliance with Nazi Germany that would have threatened British and American oil interests and supplies in the region.

⁹ Michael, *The Enemy of My Enemy: The Alarming Convergence of Militant Islam and the Extreme Right*, (University Press of Kansas, 2006), p. 113.

¹⁰ Ibid.

¹¹ Ibid.

¹² Michael, *The Enemy of My Enemy: The Alarming Convergence of Militant Islam and the Extreme Right*, (University Press of Kansas, 2006), p. 119.

¹³ Ibid., p. 118.

¹⁴ Ibid. As Michael also notes, there is evidence of limited cooperation between the Nazi regime and Zionists themselves in this matter. From Christopher Simpson's book *Blowback*, it is known that Heydrich's RSHA and the Gestapo helped Fivel Polkes train Jewish

guerillas, at camps inside the Reich, for armed terrorist actions against the British mandate in Palestine. The famous Jewish playwright, Ben Hecht, also documented in his book *Perfidy* the case of the trial of a Jewish doctor in Israel in the 1950s, for his role in rounding up Hungarian Jews and shipping them to their certain murder at Auschwitz. And there are even larger issues and little known facts than this that lurk beneath this sporadic but murderous Nazi-Zionist cooperation, which would require a book in its own right to explore.

¹⁵ Ibid., p. 115.

¹⁶ Michael, *The Enemy of My Enemy: The Alarming Convergence of Militant Islam and the Extreme Right*, (University Press of Kansas, 2006), p. 116.

¹⁷ Michael, *The Enemy of My Enemy: The Alarming Convergence of Militant Islam and the Extreme Right*, (University Press of Kansas, 2006), p. 117. Some estimates put the Muslim volunteer contingents in the Waffen SS as his as 100,000.

¹⁸ Ibid., p. 117.

¹⁹ Ibid.

²⁰ Ibid.

²¹ Ibid.

²² *The Enemy of My Enemy: The Alarming Convergence of Militant Islam and the Extreme Right*, (University Press of Kansas, 2006), p. 113.

²³ Ibid., p. 119.

²⁴ Ibid.

²⁵ Ibid., p. 125.

²⁶ *The Enemy of My Enemy: The Alarming Convergence of Militant Islam and the Extreme Right*, (University Press of Kansas, 2006), p. 120.

²⁷ Ibid.

²⁸ *The Enemy of My Enemy: The Alarming Convergence of Militant Islam and the Extreme Right*, (University Press of Kansas, 2006), p. 120.

²⁹ Martin, *The Enemy of My Enemy: The Alarming Convergence of Militant Islam and the Extreme Right*, (University Press of Kansas, 2006), p. 121.

³⁰ Martin, *The Enemy of My Enemy: The Alarming Convergence of Militant Islam and the Extreme Right*, (University Press of Kansas, 2006), p. 121.

³¹ Ibid.

³² Ibid.

³³ Ibid.

³⁴ Ibid.

³⁵ Ibid.

³⁶ Ibid., p. 123.

³⁷ See my *Reich of the Black Sun*, chapter six, for a summary of Voss's revelations to Agoston, and the sweeping technical brief given to Kammer's special weapons staff, and the sweeping nature of Kammler's actual power within the Third Reich.

³⁸ Martin, *The Enemy of My Enemy: The Alarming Convergence of Militant Islam and the Extreme Right*, (University Press of Kansas, 2006), p. 123.

³⁹ Ibid., emphasis added.

⁴⁰ Ibid., p. 122.

⁴¹ Martin, *The Enemy of My Enemy: The Alarming Convergence of Militant Islam and the Extreme Right*, (University Press of Kansas, 2006), p. 122.

⁴² Ibid.

⁴³ Martin, *The Enemy of My Enemy: The Alarming Convergence of Militant Islam and the Extreme Right*, (University Press of Kansas, 2006), p. 121.

⁴⁴ Ibid., p. 121.

⁴⁵ Martin, *The Enemy of My Enemy: The Alarming Convergence of Militant Islam and the Extreme Right*, (University Press of Kansas, 2006), p. 124.

⁴⁶ See my *The SS Brotherhood of the Bell*, pp 128-137.

⁴⁷ Michael, op. cit., p. 123.

⁴⁸ Ibid.

⁴⁹ Ibid.

⁵⁰ Ibid.

⁵¹ Martin, *The Enemy of My Enemy: The Alarming Convergence of Militant Islam and the Extreme Right*, (University Press of Kansas, 2006), p. 126.

⁵² Martin, *The Enemy of My Enemy: The Alarming Convergence of Militant Islam and the Extreme Right*, (University Press of Kansas, 2006), p. 128.

⁵³ Martin, *The Enemy of My Enemy: The Alarming Convergence of Militant Islam and the Extreme Right*, (University Press of Kansas, 2006), p. 128.



“Wiedervereinigung and the Third Position:” Germany Revives some Old Traditions

“According to legend, it was here (at Yalta) that Winston Churchill decided the fate of postwar Poland with three matchsticks, using them to show Stalin how the border would be shifted when the fighting ceased. The eastern boundary of Germany would move westward to the Oder and Neisse Rivers, and part of eastern Poland would become Russia. But Churchill also warned, ‘One day the Germans would want their territory back, and the Poles would not be able to stop them.’”

Timothy Garton Ash¹

Hardly had the Berlin wall come down and West German Chancellor Helmut Kohl’s government told East Germany “the way it’s going to be,” than the newly reunified Germany began to revive some old, long dormant, but still festering, traditional symbols. And one of the first traditional symbols to be revived, or rather, reinterred, was “Old Fritz,” King Frederick the Great:

At the stroke of midnight on August 17, 1991, a casket containing the bones of Frederick the Great was lowered into its

original resting place at the Sans Souci Palace near Potsdam. The royal homecoming extravaganza, complete with black, horse-drawn carriages, imperial flags; and a military honor guard, was broadcast live on German television. Chancellor Helmut Kohl and eighty thousand others had come to pay their respects to the legendary Prussian monarch, who ruled an enlarged kingdom from 1740 to 1786. Several onlookers nodded approvingly at a sign in the crowd that read "Prussia lives!" An ornate and lavish ceremony marked the end of a long odyssey for the body of "Old Fritz," whose remains had been spirited to western Germany in the waning days of World War II to keep them from being seized by Soviet occupation forces. The collapse of Communist rule in the German Democratic Republic paved the way for Frederick's return to his former dynastic retreat.²

As the honor guard paraded with its World War One era imperial flags and regimental colors during the night hours, the imagery could not have been lost even on a casual observer: the "New Germany" was trying to identify itself with the old.

Of course, Chancellor Kohl made the obligatory pro forma warnings about acknowledging the good with the bad, pointing out that Frederick, in addition to abolishing torture in Prussia, and being a composer in his own right and a patron of the arts, had also developed the Prussian army and expanded Prussia's borders, at the expense of Poland. No one seemed to have noticed, however, that the "bad" side of Frederick was being honored with all the "bad" traditions of the Prussian military ceremonial Kohl had just cautioned against! Perhaps that is because behind the symbolism, as will be seen, there lurked something else, for the newly reunited Germany was reviving not merely as many aspects of its traditional military pageantry as it could get away with, but the traditions of diplomacy, economics, and military muscle that Frederick epitomized.

The symbolism was not lost on students of geopolitics and history elsewhere, however. One of them, President Jimmy Carter's former national security advisor and Polish émigré Zbigniew Brzezinski -

himself trained by German historians -noted that the post-unification expansion of NATO had as much to do with Germany as it did making sure of Russia: “By enveloping Germany in a wider Euro-Atlantic framework...NATO enlargement resolves Europe’s central security problem of the twentieth century, which has been how to cope effectively with the reality of German power.”³

Whatever the value of Zbigniew Brzezinski’s prognostications about the reality of German power may be, it will now be evident from previous chapters that the Nazi International was ahead of the game, and, in fact, had anticipated this response. Moreover, as has been argued in previous chapters, they fully intended for it to come about. They not only helped orchestrate it and planned not only to be a part of it, but to *lead* it by positioning Germany at the core of a “united Europe.” And when the Iron Curtain rusted away to be replaced once again by the Iron Cross, Germany not only rushed toward *Wiedervereinigung* or reunification, but fully intended to exploit the power vacuum left in Eastern Europe by the Soviet departure and the collapse of the Warsaw Pact. This exploitation would come in the form of German economic penetration and dominance of the region, by German diplomatic efforts designed to exploit ethnic divisions in polyglot nations such as Czechoslovakia and Yugoslavia – both fictitious “nations” created by, and relics of, the Treaty of Versailles – by cleverly “recognizing” breakaway nations, and backing these up with German military force and the presence of significant numbers of German troops outside the borders of the Fatherland for the first time since the Second World War.

A. A Curious Incident: The GSG-9 and the Rescue of Andreas Strassmeir

One of the most curious exercises of German military power outside German borders after the reunification was the deployment of the GSG-9 – the same group that shot the hijackers of *Lufthansa* flight 181 and rescued all its passengers in Mogadishu, Somalia – to rescue a German national in dubious circumstances: one Andreas Strassmeir.

Only in this case, the GSG-9 was deployed not to an African third world country, but to *the United States!*

Strassmeir's rescue by the GSG-9 was effected because of his involvement on the "peripheries" of the infamous Oklahoma City Bombing. Strassmeir, according to eyewitnesses in Tulsa, Oklahoma, had been seen in the company of Timothy McVeigh at a local strip bar called Godiva's on Sheridan Avenue by a local informant for the Bureau of Alcohol, Tobacco and firearms, Carol Howe. But what was so unusual about Strassmeir that would require the involvement of the German GSG-9 to get him out of the country? Why was one young German so important?

As the circumstances surrounding the OKC Bombing began to be probed in the days and weeks immediately after the event by radio talk show hosts and independent investigative journalists, the riddles connected to the mysterious Herr Strassmeir only grew. One such radio talk show host, Chuck Harder of the People's Radio Network, reported on his show the strange events that unfolded in the immediate aftermath of the Bombing that directly concerned Strassmeir. According to Harder and his reporters, at a routine police roadblock near Muldrow and Roland, Oklahoma (just over the border from Fort Smith, Arkansas), Strassmeir was apprehended by local deputies for driving without a license or valid plates. According to some versions of the story, Strassmeir also had with him an attaché case which he refused to open and that he claimed were full of "papers."⁴

Under the circumstances, the deputy, suspicious, incarcerated Strassmeir in the local jail. Some time later, the local sheriff's department (or, depending on the version of the story, local highway patrol) began to receive phone calls insisting that the sheriff release Strassmeir. What made the calls strange, however, were that they came from no less than the then Governor of Oklahoma, Frank Keating, and a pentagon lieutenant general. Both insisted that Strassmeir had diplomatic immunity, and thus could not be arrested for anything!⁴

Then things began to get *strange*.

1. Reunification: Kohl, Günter Strassmeir, and Nazi Anniversaries

As reporters probed further into this unusual McVeigh associate, they discovered that he had come to this country with the ostensible purpose of being a participant in Civil War battle reenactments. Strassmeir told his lawyer that he merely was a Civil War enthusiast and a “reenacter” and wanted to participate in the numerous reenactments at the historical sites.

But the reality was quite different.

Strassmeir, it turned out, was a former lieutenant in the *Bundeswehr*, the German Army, and, moreover, a graduate of Germany’s prestigious Hanover War Academy, Germany’s version of West Point, and had served honorably with the German Army in its elite *panzergrenadier*, or mechanized armored infantry units.⁵ Not only this, but Strassmeir resided at Elohim City, a notorious white supremacist religious group in Oklahoma with its own deep and broad connections to a variety of underground American neo-Nazi and white supremacist groups. Moreover, Strassmeir was the compound’s “security chief,” who trained the group in survival tactics, small arms tactics, guerilla operations, and so on.

But even *that* is not all:

... the German paramilitary expert admitted in a court affidavit that he had met McVeigh at a Tulsa gun show shortly after the Waco massacre. Strassmeir sold a combat knife to McVeigh and gave him his business card. That’s as far as it went, according to Strassmeir, who insists that he had no further dealings with McVeigh.

While in Tulsa, Strassmeir also visited the home of his beer-drinking buddy, Dennis Mahon, the Oklahoma-based Klansman who lit crosses in reunified Germany. And Mahon often spent weekends at Elohim City, boozing it up with Strassmeir....

Strassmeir denies any involvement in the Oklahoma City attack. There is no doubt, however, that he had extensive links to America’s violent racist underground. Strassmeir’s roommate at Elohim City was Michael Brescia, who subsequently confessed to his own role as a member of the Aryan Republican Army (ARA), a fanatical white supremacist

sect that sought to overthrow the U.S. government, purge the country of blacks and Jews, and install a new legal system based entirely on their own weird interpretation of the Bible. (Four of the six known ARA members lived at Elohim City or often visited there.) To raise money for the cause, the ARA robbed twenty-two banks in eight Midwestern states during the mid-1990s. These armed assaults were carried out by ARA extremists who had been trained in weapons and guerilla tactics by Strassmeir....

The ARA's German paramilitary instructor managed to elude the long arm of the law, even though the Oklahoma State Patrol had issued a BOLO ("Be on the look-out") alert for Andreas Strassmeir, which indicated that he was an armed and potentially dangerous "illegal alien." Although several U.S. government agencies were aware of Strassmeir's presence at Elohim City, immigration authorities never tried to deport him.⁶

As the news reporters doggedly sniffed out the Strassmeir trail, however, it suddenly went completely cold...

...Until the young German suddenly showed up at his family home in Berlin, gave a brief press conference stating that he was indeed alive and well and not completely missing – after all, by that time, all of America's law enforcement agencies were looking for him – and then faded quietly from view. So what had happened between the mysterious phone calls to the local law enforcement in Roland, Oklahoma from Governor Keating and the anonymous Pentagon lieutenant general, and Strassmeir's sudden reappearance in his native Germany?

According to Strassmeir's close friend and American attorney, Kirk Lyons – a man not without his own connections to America's radical underground right⁷ – and others, Strassmeir was spirited out of this country by none other than Germany's elite GSG-9 commando unit! Substantiating claims of Strassmeir's possible deep involvement and connection to intelligence and elite paramilitary units, researcher Victor Thorn recounts two relevant incidents. Shortly after arriving in this country, Strassmeir eventually made his way to Texas where he

aligned himself with a citizen's militia called the Texas Light Infantry Brigade. The only problem was: the members of the group quickly became suspicious of Strassmeir's motivations and loyalty, so they followed him late one night to a federal building. There, they saw Strassmeir approach an electric lock on the door, upon which he punched in the code on an electronic keypad. And just like that, Strassmeir gained access to the building. What makes this scenario relevant is that the federal building conveniently housed an office of the ATF. Anyway, after witnessing this transgression, the (Texas Light Infantry Brigade) gave Strassmeir his walking papers for being a suspected undercover agent.⁸

Thorn then zeros in on the obvious questions this incident provokes:

At this point we must ask ourselves: who was Andreas Strassmeir? On July 14, 1996, *The McCurtain Gazette* reported that, according to a highly-placed source at the FBI's intelligence division, he was a paid ATF informant or asset sent to infiltrate Elohim City. This sentiment was echoed by Timothy McVeigh's lawyer, Stephen Jones, during a 1998 interview on KTOK radio in Oklahoma City. Jones said Strassmeir was a German national recruited by (then FBI Director) Louis Freeh to do deep undercover and intelligence operations for the FBI in the United States. He also said that he discussed Strassmeir's FBI alliance to the German government with U.S. prosecutor Beth Wilkinson. There is also (an) FBI form 302 which has been unearthed stating that Strassmeir was a CIA asset on loan from the German government. Now, as you've noticed, three different agencies have been mentioned – the FBI, ATF, and CIA – in relation to who (sic) Strassmeir was working for. And until our government is more forthcoming with information, we can't be certain of any more precise details other than he was a shared asset on loan to the U.S. government.⁹

In other words, as the story unfolded, Strassmeir was revealed to have the following connections:

- 1) Known connections to Timothy McVeigh;
- 2) A known connection to the American far-right and “white supremacist” groups via his attorney Kirk Lyons and his role as security chief for Elohim City;
- 3) Known connections to the German Army, in which he was a former lieutenant and graduate of the Hanover War Academy, Germany’s “West Point;”
- 4) Highly probable connections to American intelligence –the FBI, ATF, and CIA have been mentioned – as well as powerful American influences that were wielded on his behalf from the American military, the State Department, and Oklahoma Governor Frank Keating.

With these connections, it is highly *unlikely* that the story of Strassmeir’s rescue in this country by the GSG-9 that was initiated by his attorney Kirk Lyons is true, since such influence as was wielded on his behalf by American sources could more than easily have surreptitiously spirited him out of the country.

However, there is one highly significant fact that places the story of the GSG-9 rescue of Strassmeir in a very *different* light, making it not only *possible* that it was involved in Strassmeir’s rescue, but *likely*. When the Berlin Wall came down and West Germany for all intents and purposes annexed East Germany, Andreas attended the reunification ceremonies with his father, Günter Strassmeir, and Chancellor Helmut Kohl himself. This is significant, for after Strassmeir showed up in Berlin once again after having suddenly disappeared in the U.S.A., American officials investigating the Oklahoma City Bombing attempted to question him in 1997, and requested intelligence files and information from the German government.

Germany, not surprisingly, replied that it had no police or intelligence files concerning Strassmeir and absolutely no data on him whatsoever, an odd statement given the fact that Strassmeir was a former officer in the German Army, a graduate of its war academy, and more importantly, *the son of Günter Strassmeir, the head of the*

*Christian Democrat Union party in Berlin, Chancellor Kohl's chief of staff, a minister-without-portfolio, and one of the masterminds of the German reunification itself.*¹⁰

And the date when East and West Germans climbed the Berlin wall and began to tear it down by hand was November 9, 1989, a significant Nazi anniversary, for on that night in 1938, the notorious *Kristallnacht* or "Night of Crystal" occurred, when Nazi storm troopers openly sacked, vandalized, and looted German Jewish shops and brutalized German Jews openly and publicly. Moreover, on that same date in 1923, Adolf Hitler led his abortive putsch attempt against the state government of Bavaria.

2. Implications of the Incident: U.S. Complicity or Not?

Given these revelations, how then does one interpret Andreas Strassmeir's sudden *disappearance* in this country and his sudden *reappearance* in Berlin, for clearly he had *some* covert help in eluding U.S. investigators probing the OKC Bombing. The question is, who was ultimately controlling him and pulling the strings to get him out of America? There are three basic ways of interpreting the clues:

- 1) Strassmeir was working for *German* intelligence and was on loan to the U.S.A.'s intelligence agencies as an undercover agent to penetrate American neo-Nazi and white supremacist groups with ties to European groups. In this case, his father pulled diplomatic strings and high level American pressure was exerted to obtain his release from local law enforcement. Since American intelligence was also investigating the Oklahoma City Bombing, the U.S. may have told the Germans that it was too sensitive for them to get Strassmeir out of the country themselves, and that the Germans would have to do it on their own without American involvement;
- 2) Strassmeir was working for American intelligence directly, and when his cover was blown by the initial post-bombing investigations, Strassmeir's father decided it was too hot of a situation and exerted pressure to obtain his release, and

called upon his friend, Chancellor Kohl, to deploy the GSG-9 and smuggle his son back to Germany;

- 3) Strassmeir was playing both German and American intelligence for fools, and was working sincerely for his American radical right and white supremacist contacts, and directly for some hidden “neo-Nazi directorate.” Given the power and extent of Neo-Nazi influence within Germany itself and particularly in Kohl’s government, pressure was exerted on the German government – and it probably did not require *much* pressure – to deploy the GSG-9 and smuggle Strassmeir out of the U.S.A. safely back to Germany.

As unlikely as the last scenario sounds, there is circumstantial evidence that suggests a hidden Nazi influence at work not only in the German reunification itself, but that also suggests that the GSG-9 was indeed covertly deployed to the United States without the latter’s consent or knowledge to return the German spy and *agent provocateur* to Germany.

3. Kohl’s Neo-Nazi Connections and the Neo-Nazi Push for Reunification

To see what that circumstantial evidence is, one must look closer at the then German Chancellor, Helmut Kohl, himself. Kohl had personally awarded and decorated a German industrialist, Fritz Ries, with the *Bundesverdienstkreuz*, or Federal Cross of Merit. Ries during the Second World War made his fortune by appropriating “Aryanized” Jewish property seized from Jews sent to the death camps, and in fact had operated factories near Auschwitz that relied on slave labor from the camps.¹¹ This was not a mere accident or oversight on Kohl’s part nor a lapse of proper vetting of Ries by his staff, for Kohl was a well-known attendee and public speaker throughout his Chancellorship to the Silesian Expellees’ Society, from which he also received substantial campaign contributions. The Silesian Expellees’ Society is one of many such societies in Germany, composed of Germans or their descendents who lost their

homes and land to Poland when the latter country was shifted westward and absorbed Germany's eastern provinces. Most of these societies are well-known to have deep Neo-Nazi connections, and Kohl's government either openly supported such societies or tolerated their activities.¹²

Not surprisingly, given the Kohl Government's own open use of revived symbols of German militarism – witness only the ceremonial burial of King Frederick the Great with full Prussian-style military honors – and his support for, and support by, expellee societies, the amount of violence against non-ethnic Germans in the newly reunified Reich rose significantly, as did neo-fascist political victories in local and state elections. German police, for example, found “a neo-Nazi bomb factory in Jena and confiscated sizable amounts of dynamite, machine guns, ammunition, and military gear. The local prosecutor said the arsenal reflected ‘a new quality in weaponry and violent preparations’ of German neo-Nazi groups.”¹³ Such incidents were repeated across the country, as will be seen momentarily.

More importantly, the reunification revealed another sinister fact about post-reunification German – and Eastern European – politics, for despite the fact of decades of Communist rule, neo-Nazi, neo-Fascist and radically right wing nationalist groups had secretly grown and festered throughout Eastern Europe, and nowhere more strongly than in the provinces of the former East Germany. For example, in elections held in April of 1998, *Deutsche Volksunion*, a scarcely disguised neo-Nazi political party, managed to win a stunning 13 percent of the vote in regional elections in Sachsen-Anhalt province. Another thinly disguised neo-Nazi party, the National Democratic Party, also won significant percentages in other local elections in the former eastern zone. These successes were attributed to the fact that these parties appealed to smoldering German resentment against the number of non-ethnic German foreign workers in the country who, the parties alleged, were stealing jobs from native Germans.¹⁴ No one seemed to have noticed that the former eastern zone had less than one percent of its population composed of such foreign workers.

With these election victories and Kohl's reelection bid pending at a national level, his government and Christian Democratic Union party

careened to the political right to such an extent that it became “increasingly difficult to discern where political expediency ended and right-wing extremism began.”¹⁵ Why had Kohl and the Christian Democratic Party lurched so far to the right – a dangerous move even after reunification, since the vast majority of Germans who lived in the former West Germany would never support such a government (at least, not openly).

4. *The Shotgun Wedding*

In order to appreciate the full significance of the neo-Nazi connections of Kohl’s government, his party’s rightward lurch, and the subsequent policies of his “left wing” Social Democrat successor, Gerhard Schröder, it is necessary to examine the real -though in the United States almost unknown - role that neo-Nazi groups actually played in *orchestrating and driving the reunification*.

As open protests against Communist regimes grew throughout Eastern Europe, first in Poland with Lech Walesa’s Solidarity movement, and then other eastern European nations, similar protests naturally began in East Germany, the most notoriously “Communist” and pro-Soviet government in the former Warsaw Pact. Initially these protests were led by East German intellectuals who, far from desiring a collapse of the East German state and reunification with the much more powerful West German government in Bonn, merely wished to introduce reforms that would introduce a mix of socialism and capitalism – the Nazi-inspired “third way” once again! – to the East German state.

But as the protests spread throughout East Germany and finally reached Berlin, with West Berliners and East Berliners climbing the wall and beginning to tear it down, something else had happened. The covert neo-Nazi groups in the eastern zone came out in force, and propelled the release of populist energy in a new direction, reunification:

Emblematic of this shift in sensibility, the original chant of “*Wir sind das Volk!*” (“We are the people!”) gave way at mass

rallies to the rousing refrain "*Wir sind ein Volk!*" ("We are one people!")

And of course, the phrase "*ein Volk!*", "one people," was itself part of a classic Nazi propaganda slogan: "*Ein Volk, ein Reich, ein Führer!*": "One People, one *Reich*, one Leader!" Shortly after the appearance of this slogan,

It did not take long before the uglier side of German nationalism began to assert itself. In Leipzig and other East German cities, skinhead youth hoisting flags of the 1937 German Reich marched alongside of those demanding unification. Soon proponents of unity, including neo-Nazi militants, started to clash openly with those who still cherished the possibility of an independent East German state.¹⁶

It does not take a Nazi rocket scientist to figure out the parallelism at work, for in a manner similar to the Nazi Party's original private army of brown shirts, which literally physically brutalized its political opponents into submission and silence, those opposing reunification were physically silenced and effectively closed out of any debate.

On the other side of this fast-crumbling Iron Curtain, West German Chancellor Kohl was driving the process of unification "at breakneck speed,"¹⁷ weighing in with a "unilateral plan to unite the (German Democratic Republic) and the Bonn Republic."¹⁸ And the man who played a significant role in the formulation of that suspiciously ready-to-hand reunification plan was none other than West Berlin Christian Democratic Union party chief, Günter Strassmeir, whose son Andreas was a former German officer with deep connections to America's radical right. This fact, more than anything else, indicates why Germany probably *did* deploy the GSG-9 to the U.S.A., and why it may have done so without America's knowledge or consent, for if Strassmeir had been apprehended and held in American jails, even more compromising information damaging to Kohl's government may have come to light.

So what do we have? According to the popular media portrayal of the reunification, we have a set of “coincidences”:

- 1) A coincidental outbreak of public protests against the Communist East German regime led by East German intellectuals demanding significant reforms and a continuation of the East German state in a “third position” between western capitalism and Soviet Communism, a position historically that of German foreign policy and a now well-demonstrated Nazi postwar policy that reappears time and again in regions or countries where postwar Nazis had a significant influence;
- 2) The subsequent co-opting of this spontaneous outbreak of German populism in East Germany by the open appearance of neo-Nazis who change the nature of the protestors’ demands from reforms to reunification, which is accompanied by the use of revived and thinly-disguised Nazi propaganda slogans and the open display of flags and banners of the Nazi Reich;
- 3) These events culminate “coincidentally” on the night of November 9, 1989 when East and West Berliners storm the Berlin wall and begin to demolish it, on the anniversary of the *Kristallnacht* anti-Jewish pogrom and of Hitler’s 1923 Munich Beer Hall *putsch* attempt;
- 4) Kohl’s government weighs in with a unilateral plan for the reunification – which implies a degree of *preparation and foreknowledge* on the part of his government that the events in the eastern zone would unfold as they would;
- 5) Subsequently Kohl allows and promotes the resurgence of the use of the traditional symbols of the German military, and establishes the symbolic connection of his government with the “old Germany” by a full honors reinternment and burial of king Frederick the Great in Berlin, and later authorizes a Prussian-style torchlight military ceremony at the Brandenburg Gate celebrating the removal of Allied and Soviet troops, while simultaneously,
- 6) Kohl and the Christian Democratic Union openly court the expellee societies, and his reunification advisor’s son,

Andreas Strassmeir, is spirited out of the United States after American investigators identified him as a significant and suspicious figure in the associates of Tim McVeigh.

Given the significant level of neo-Nazi influence and open activity in driving the reunification from the East German side, Kohl's own suspiciously ready-to-hand plan for reunification, his connections to expellee societies with Nazi connections, and the allegations of Andreas Strassmeir's connections to American white supremacist and neo-Nazi groups, one cannot altogether discount the distinct possibility that driving all these events is a "deep politics" and deeply hidden masters with very deep, well-connected Nazi roots.

In a maneuver reminiscent of Hitler's Saar Plebiscite of 1935 that threw the French out of the coal-rich Saar and paved the way for Hitler's subsequent step-by-step dismantling of the Versailles Treaty (with the reintroduction of conscription the same year and the reoccupation and remilitarization of the Rhineland a year later), Kohl's plan of reunification cleverly called for the East Germans themselves to decide whether or not to reunite with West Germany. Needless to say, they voted overwhelmingly to do so, and there was little an economically weakened Soviet Union under Mikhail Gorbachev could do about it. It was, as author Martin A. Lee puts it, "more like a shotgun annexation than a marriage of equal partners."¹⁹

5. The Ugly Side of Reunification

a. The Rostock Incident

In addition to all these "coincidences," a series of violent attacks against ethnic non-Germans throughout the newly reunified country broke out "spontaneously," primarily in the former East Germany. Utilizing a neo-Nazi computer network called the Thule network, an international "electronic fascism" consisting of a tapestry of bulletin boards, blog sites and so on, and cell phones, Neo-Nazi groups published information on political rallies, how to publish newsletters,

and gave practical advice on the use of paramilitary political violence.²⁰

One of the most significant of these violent attacks against non-German ethnic groups was the Rostock Incident:

At times, German neo-Nazi leaders were able to beat the authorities in a game of cat and mouse by using computers, walkie-talkies, portable phones, and answering machines. New methods of communication enabled the neo-Nazis to avoid police roadblocks and deliver commands to convoys of ultrarightists as they made their way to political demonstrations. Such high-tech gimmickry was employed in late August 1992, when Ewald Althans and hundreds of his cohorts slipped into the Baltic seaport of Rostock in eastern Germany under the cover of darkness. Some had come all the way from Austria and Scandinavia to participate in a frenzied outburst of ethnic cleansing.

In a scene starkly reminiscent of the 1930s, thousands of local residents roared approvingly as a throng of neo-Nazis attacked a refugee center for Romanian Gypsies. As the immigrant shelter went up in flames, an ecstatic crowd sang "Tannenbaum" (A Christmas hymn) and "Deutschland über Alles." A local law-enforcement official, Jürgen Deckert, later acknowledged that "the police had an arrangement with the rowdies not to intervene."

While the police stood idly by, the neo-Nazis regrouped and attacked another guest hostel with a barrage of Molotov cocktails. More than a hundred Vietnamese guest workers and their families were trapped inside the burning building, along with a German television crew. The reporters telephoned Rostock's fire and police departments in a futile attempt to summon help. Nearly suffocating from smoke, the terrorized inhabitants moved from floor to floor until they reached the top level of the twelve-story apartment complex. Down below, the angry mob screamed, "Lynch them!" and "Blood justice!" With only minutes to spare before the entire structure turned into a deadly inferno, they pried open a locked door with iron bars,

crawled onto the roof, and narrowly escaped by leaping to the top of another building. Miraculously, no one was killed.

Government authorities in the German state of Mecklenburg-West Pommern subsequently disclosed that they had learned of neo-Nazi plans to “clean up” Rostock before the violence erupted, yet no preventive measures were ordered. Interior Minister Rudolf Seiters refused to call out the Bundesgrenzschutzpolizei (Germany’s national military police) to defend the Rostock refugee center, allegedly because of a shortage of manpower. But plenty of heavily armed law-enforcement personnel were available when more than a thousand antifascists turned up in town to show solidarity with the beleaguered foreigners. Suddenly keen to assert their authority, the police arrested ninety people, two-thirds of whom had come to protest the neo-Nazi violence. By tuning into police banter on citizens-band radio and jamming official signals, the neo-Nazis had a distinct advantage over their antifascist foes during street clashes that turned Rostock into a virtual combat zone. “It was terrible, like a civil war,” said a stunned Rostock resident....

The week-long pogrom tapered off after the German government caved in to the neo-Nazi mob by ordering all refugees out of Rostock. Henceforth, this economically depressed city of 250,000 would be foreigner-free, just like Hoyerswerda and several other ethnically cleansed redoubts in the Fatherland. Next came an official announcement that close to one hundred thousand Gypsies would soon be deported to Romania and other parts of Eastern Europe...

Neo-Nazi leaders were jubilant over the course of events. By meeting their demands, the German government had allowed a violent minority to decisively shape the national political agenda.²¹

The sense of a terrible *déjà vu* that hangs over these events cannot be gainsaid, discounted, nor excused, nor did responsible voices in the Kohl Government and the German media seek to do so. And the vast majority of German citizens themselves were horrified at the

events. They may indeed have cost Kohl the Chancellorship in his loss to Social Democrat Gerhard Schröder in 1998.

In the light of the total context of the previous seven chapters, and in the light of the chapters to come, one may perceive it for what it really is: the exploitation on the European scene of the same ethnic and economic tensions the Nazi International exploited so successfully elsewhere in the postwar world. And that means that as late as the mid-1990s, Martin Bormann's Nazi International was alive, well, and able to mount a coordinated effort right in the heart of Europe, and to drive both sides of a crisis in a classic Hegelian fashion by carefully advocating an "East German Third Position Reform" as the thesis, propelling the neo-Nazi cooption of that movement by demands for reunification, yet another "Third Position", and proposing a unilateral scheme for reunification from Kohl's "expellee society-influenced" government itself. Make no mistake, this is not some "flaw in the German national character" or some wayward gene in the Teutonic gene pool; this was the result of an evil, brutal, and genocidal ideology that once ruled and exploited those flaws, and that was still well-organized, well-financed, and inherently predisposed to do so once again. Without the neo-Nazis, there would have been no reunification.

b. The Post-Reunification Surge of Terrorism

But there is another as yet unexplored consequence of German reunification and of the forces that propelled it, and it remains unexplored primarily because it is so obvious. According to German officials themselves, in 1992 the amount of firebombings and explosives attacks in Germany skyrocketed almost 33 percent from the previous year. Similarly, they also noted an increase in the number of organized right-wing extremists to well over 65,000, approximately "10 percent of whom were deemed to be hard-core neo-Nazi militants."²²

The violence grew proportionally to the increasing passivity not only of the average German citizen but of the Kohl Government itself, reaching such a pitch that even the U.S. Army formulated a report indicating its own concerns about the safety of American military

personnel, especially those of non-Caucasian races.²³ Indeed, many in Germany and elsewhere actually began to question whether or not the neo-Nazis were “functioning as a de facto fifth wheel of state policy, forcing foreigners to leave the Fatherland under a hail of bullets, bombs, and baseball bats”.²⁴ Even the Social Democrats capitulated to Kohl’s demands and, in a crucial alignment with his Christian Democrats, mustered the necessary two thirds majority in the *Bundestag* to amend the German federal constitution closing Germany’s borders to political refugees and asylum-seekers. It was a modification that neo-Nazi groups began to demand almost as soon as West Germany was granted national sovereignty by the western Allies in 1949. Not surprisingly, the German government began to enlist the same neo-Nazi skinheads that had driven the populist demands for reunification into its *Bundesgrenzschutzpolizei*, its national military border police, to make sure Germany’s borders were truly and genuinely *closed*.²⁵

To put it succinctly, the German reunification may be the best example of the postwar Nazi International’s manipulation and exploitation of conflict by means of the Hegelian dialectical technique, for at each stage of that technique – thesis, antithesis, synthesis – one finds the presence of neo-Nazis, their friends, or their ideas.

B. Flexing Muscle and Other Old Traditions of the Third Position

1. The Soviet Implosion

No sooner was the Fatherland “one big happy Reich” once again than Germany began to flex its economic – and military – muscle on the European stage:

The precipitous implosion of the Soviet Union into fifteen separate countries left a huge power vacuum on the Continent – a vacuum that a reunified Germany, by virtue of its pivotal location and economic might, was poised to fill. No longer confined to the perimeter of the Atlantic system, Germany would once again become the arbiter of *Mitteleuropa*, a geopolitical construct that lay dormant while the Federal Republic bode its

time as a frontline state during the Cold War. German hegemony throughout the region, whether consciously pursued or otherwise, appeared to be a *fait accompli*. “Central Europe is going to have a strong German flavor again,” said retired State Department officer Douglas H. Jones. “Even if it’s not intentional, Germany could lurch into a destabilizing role.”²⁶

In a certain sense, the Soviet implosion and the collapse of the Warsaw Pact created such a vacuum that Germany literally could be, and was, sucked into a dominant role in Eastern Europe once again.

2. German Investment Strategy

But it was not as if the German government and German business were not *ready* for the eventuality. The high cost of reunification necessitated a penetration in depth rather than breadth into the smaller economies of Eastern Europe. Accordingly, “Germany invested strategically, rather than profusely, in Eastern Europe, focusing on crucial areas such as energy supplies, transportation, telecommunications, and mass media.”²⁷ This soon translated into new political muscle on the world stage, and a “bossier manner” as Germany began to insist upon a “United Nations Security Council seat” and that “German be elevated to the status of an official language within the European Community.”²⁸

3. Breaking Free of NATO

These moves were almost simultaneously accompanied by similar German assertiveness regarding NATO and its own armed forces. Germany’s Constitutional Court, in a crucial 1994 ruling, declared that the German Armed Forces could participate in military operations beyond NATO’s jurisdiction, and the then German Defense Minister Wolker R uhe, in a *Bundeswehr* (German Army) White Paper circulated within the upper echelons of the German defense and intelligence establishment that same year, stated that “the German army would henceforth function as ‘an instrument of

foreign policy.”²⁹ This was classic Prussian military and foreign policy restated, for it was Von Clausewitz himself in his classic *On War* who stated the maxim that war is diplomacy by other means. Reunified Germany had served notice, quietly, but very firmly, that the gloves were off once again, and that Washington and Moscow would no longer have virtual veto power over Germany’s defense and diplomatic agendas. As the then German Foreign Minister Klaus Kinkel put it, the 1994 court decision and *Bundeswehr* White Paper gave Germany “Freedom of action in foreign policy. The brake that was holding us back is gone.”³⁰

4. *Germany and the Arms Trade*

With all these statements and maneuvers happening quietly while most major Western media outlets scarcely covered them, it should come as no surprise that newly reunified Germany quickly became the world’s second largest exporter of arms, second only to the United States.³¹ And after having absorbed the former East German army, Germany could afford to *reduce* its standing army to 350,000, which still made the well-equipped and competently led *Bundeswehr* the largest army in Europe,³² and one of the largest standing armies for a nation of its population in the world.

But Germany’s intentions did not stop there. NATO itself, which had been intended as a check on both Soviet, and at the time of its formation, potential German expansion, was now revealed for what it was, as least, as far as Germany perceived it:

Although NATO was supposed to contain Germany as well as Russia, it proved to be the vehicle through which German military power was restored. And now that the superpower face-off had ended, German leaders indicated that they were ready to develop new security structures outside of NATO, including a European military force composed initially of 35,000 French and German soldiers.³³

The modern French military – no resemblance to the demoralized French military of the Third Republic that performed so poorly against the German Wehrmacht in 1940 – not only is very well-equipped and well-led, but France, as the world's third largest thermonuclear power, coupled with Germany, would be a powerful economic and military alliance in its own right. The proposal from the newly relocated German government in Berlin was, needless to say, the source of some consternation at green-topped conference tables in Washington, D.C., and Wall Street, where the continental outlook of both European powers might well indeed translate into such “new security measures.”

But even greater concern was quietly expressed when German military think tanks openly reasserted the German claims to sovereignty and “Germany’s nuclear weapons research program.”³⁴ Even the publisher of Germany’s popular “liberal” magazine *Der Spiegel* (*The Mirror*) openly declared that situations could be conceived that Germany would have to have its own nuclear deterrent “in spite of existing treaties.”³⁵ Yet, with world attention focused on Iran’s potential nuclear pop-gun, not a word has been said in the major western media about the far larger nuclear – and thermonuclear – potential of Germany, which, like Japan, could arm itself to the teeth with such weapons in a very short time if the situation demanded, for in fact, Germany never *stopped* perfecting and developing the means of isotope enrichment that it had begun to develop in World War Two,³⁶ and indeed, was one of the world’s major exporters of such technologies along with Russia and France.

5. Germany and Saddam Hussein’s WMD’s and Secret Police

If there is any doubt about Germany’s role in the proliferation of nuclear weapons, consider only Bonn’s role in the military buildup of Saddam Hussein’s Iraq, a role that, in spite of the U.S. media’s description of the facts, far outstripped the Soviet Union’s role, for it was Germany, not Russia, that gave to Saddam the beginnings of his nuclear, chemical, and biological weapons programs:

With the full knowledge and cooperation of the federal government and its BND spy apparatus, dozens of German companies were instrumental in helping Saddam Hussein develop one of the world's most diversified unconventional-warfare arsenals. Several of West Germany's biggest firms supplied equipment and expertise to set up entire plants for the production of nuclear, chemical, and biological weaponry. Other countries, including the United States, cashed in on the macabre bonanza that created Iraq's high-tech death machine during the 1980s, but Bonn's role far outstripped the international competition. In addition to constructing Saddam's underground bunker and extending the range of the Scud missiles to be able to hit Israel, German engineers concocted new delivery systems for poison gas and dispensed advice on the most efficient way to enrich uranium into weapons-grade fuel for a nuclear bomb.³⁷

What had begun long before as German and Nazi intelligence interest in Iraq finally bore fruition, as those contacts, never really erased by the war, were able to leverage these lucrative arms contracts for Germany. More importantly, as I noted in my previous book *The Cosmic War: Interplanetary Warfare, Modern Physics, and Ancient Texts*, Germany's assistance to Iraq also came in the form of on-the-ground German support for the numerous archaeological projects begun under Hussein's regime. While the German archaeologists and their French colleagues were withdrawn from that country prior to the American invasion in 2003, the German intelligence service, the *Bundesnachrichten-dienst*, maintains a heavy presence in the country.³⁸

Bonn, in fact, from the period of the first Gulf War in 1991 up to the second Anglo-American invasion in 2003, bluntly thumbed its nose at repeated American and United Nations trade embargos on Iraq and "continued to provide Iraq with missile parts, chemical agents, and state-of-the-art engineering equipment," and "later it would be disclosed that the BND had trained Iraqi and Libyan secret police units."³⁹

6. *“Third Position” German Initiatives in Eastern and Central Europe*

These abrupt policy and attitude changes in Bonn and Berlin after the reunification were quickly followed up by very real flexing of German military and diplomatic muscle in several independent moves that signaled Germany’s new independence on the international geopolitical scene. These initiatives concentrated on “revising Versailles” once again, by exploiting the growing nationalism within Versailles-created multi-ethnic “nations” such as Yugoslavia – a polyglot nation with significant minorities of Roman Catholic Croats, Bosnian and Kosovan Muslims, and the majority Eastern Orthodox Serbs – and Czechoslovakia, another polyglot nation stitched together from Bohemian Czechs to Slovenian Slovaks and Ruthenians. And more ominously, Germany quietly signaled that it was also prepared to begin the long-term recovery of its lost eastern provinces, areas of territory occupied by modern-day Poland and Russia. Indeed, if the newly reunified Germany was to dominate *Mitteleuropa* and eastern Europe once again, these two relatively powerful polyglot nations, Czechoslovakia and Yugoslavia, created by Versailles precisely to encircle Germany, had to be broken apart. If this sounds familiar, it should, for Adolf Hitler did one and the same thing to both countries, breaking Czechoslovakia apart prior to absorbing it, and absorbing Yugoslavia before breaking it apart and recognizing a puppet Nazi-controlled regime in Croatia.

a. Revising Versailles Once Again: Germany and the Crack-up of Czechoslovakia

Czechoslovakia was once again the first nation to fall before reunified Germany’s new post-Cold War new order in Europe. In 1992 Czechoslovakia broke apart into two parts,

A rupture fostered in part by a German foundation closely linked to the Christian Social Union (the Bavarian sister party of Kohl’s CDU), which channeled funds to Slovak separatists and supported the rise of Slovakian strongman Vladimir Meciar, who enjoyed cordial relations with Bonn. During this period, the

Sudetendeutsche Landsmannschaft and its neo-Nazi allies stubbornly maintained that ethnic German expels and their descendants should be allowed to resettle in the Sudetenland—which composed one-third of the (remaining) Czech Republic – while retaining their German citizenship.

Note that Czechoslovakia was broken apart *by almost **exactly** the same means that Nazi Germany used in 1939 to accomplish the same thing:*

- 1) covert German funding of Slovakian nationalism culminating in a breakaway of that province to form its own government under a German puppet installed in Bratislava (is this March 1939? Or is it 1992? Is it live? Or is it Memorex?);
- 2) Neo-Nazi (or is it just plain old Nazi?) demands that Sudeten Germans in the border regions of Bohemia be granted special privileged status within the Czechoslovakian state. Is this September, 1938? Or 1992? Are these *neo-Nazis*? Or “just plain ole’ Nazis”?

Obviously, Czechoslovakia was once again broken in two. But the new Germany was much subtler than Hitler, taking, perhaps, a page from Heinrich Himmler’s playbook:

Pressed to compensate Hitler’s Czech victims, Bonn raised the matter of financial compensation for the property expropriated from 2.5 million Sudeten Germans after the collapse of the Third Reich.

(Is it live, or is it Memorex?)

After Czech courts nixed the idea,

(Is it live, or is it Memorex?)

German finance minister Theo Waigel delivered a political broadside in which he barely masked a threat to block Prague's entry into the European Union.

(Is it live, or is it Memorex?)

Czech officials were furious, but they could ill afford to cross swords with Bonn. With German capital accounting for the lion's share of foreign investment in the Czech Republic,

(Remember that clever German business plan to buy control of energy, transportation, telecommunications, and mass media? And whose plan does that sound like?)

Bonn had considerable leverage over its neighbor. "The status of the Czech Republic has gone from that of a Soviet satellite to that of a German protectorate," declared a commentator for the *Prague Post*.⁴⁰

And well might the *Prague Post* have complained, for entry into the German-dominated European Union did indeed transform the Czech Republic, basically nothing more than the province of Bohemia-Moravia, from being a Russian satellite into a German economic protectorate for the second time in its modern history. Nor was the use of the word "protectorate" by the *Prague Post* accidental, for as any Czech well knows, Heinrich Himmler, with Adolf Hitler's permission, had transformed the entire country into the *Reichsprotectorat-Böhmen-Mähren* (Reich Protectorate of Bohemia and Moravia) under the exclusive jurisdiction of Himmler's SS and its private SS economy, dominated by the large and powerful German cartels.

All that was missing this time were the black uniforms and jackboots.

b. Silesia, "Kaliningrad," and Poland

Poland watched all of this (and once again, is it live, or is it Memorex?) with growing uneasiness, as similar German maneuvers unfolded in Silesia, Pomerania, “and what used to be East Prussia.”⁴¹ Only this time, the covert moves were a little more overt (is it live, or is it Memorex?):

Neo-Nazis from across the Oder-Neisse line sought to galvanize support for a German takeover of large chunks of Polish territory. As in the Sudetenland, neofascist agitation paralleled, and in some ways complemented – efforts by Bonn-backed (expellee) groups that supplied revanchist propaganda to ethnic German enclaves in Poland. Several neo-Nazi groups focused on Upper Silesia, an area rich in coal, iron, and other natural resources⁴²

This time, however, there was a change in tactics, as Neo-Nazi groups, with funding from “somewhere,” openly purchased former German lands from cash-strapped Poland, and established radio stations, printed newsletters, posted bilingual street signs in Polish and German, and changed the names of villages, once a sufficient German presence was reestablished, from their Polish names back to their German ones.⁴³

In other words, the Neo-Nazis, with probable covert backing of the Bonn government, were deliberately *creating a German minority in Poland by buying up formerly German property in the formerly eastern provinces of the Reich.*

But why call Bonn’s role in this activity “probable and covert”? Answer: Poland naturally protested these activities directly to Bonn. Bonn’s response was to demand that Warsaw give special rights and privileges to *Volkdeutsche* in Silesia and Pomerania, and that they be allowed to carry German passports and vote in German elections. Warsaw “had little choice but to knuckle under” and caved in to these demands.⁴⁴ Yet, the German *Bundestag* refused to pass similar legislation recognizing the special status of minorities within its borders.⁴⁵ Indeed, as has already been seen, Kohl and the

opposition Social Democrats combined for a majority that amended the German constitution, abolishing its provision granting special asylum status to refugees. And as already been seen, German law enforcement officials turned a blind eye to the neo-Nazi-inspired violence of the Rostock incident. These policies quickly raised concerns – among the few who were actually following the post-unification attitudes of Germany *closely*– that Bonn was simply reviving some old traditions (with appropriate Nazi and neo-Nazi embellishments), of German power politics and diplomacy.⁴⁶ And almost *nothing* of these events or their significant implications were reported in or analyzed by the American television media.

Similar machinations befell the Russian *oblast* or province of Kaliningrad, which was but the northern portion of the former German province of East Prussia. The German city of Königsberg had been renamed Kaliningrad by the Soviets, who openly annexed the province at the end of the war, and tried their best to Russianize it, transforming the port city into a major Baltic naval base for the Soviet Navy. With the collapse of the Soviet Union, however, and the dissolution of the Warsaw Pact, the Kaliningrad *oblast* hangs precariously isolated between the German-dominated Baltic-states and Poland.

This time, Bonn was not so subtle, for it openly offered government financial incentives to any Germans, including relatives of the original German inhabitants of the city, to settle in “Kaliningrad.” The city soon “became a magnet for right-wing extremists,”⁴⁷ who moved to the city in droves, bringing a host of German corporate branch offices, including a newly opened branch of *Deutsche Bank*, not far behind them. It is significant that the German Government, which has on the books of its legal code laws against legitimizing Nazism or neo-Nazism nonetheless opened its treasury to such groups who wished to move to “Kaliningrad.” The city has thus become a haven, almost a “Vatican,” for European-based neo-Nazi groups.

c. Revising Versailles Yet Again: Germany, Croatia, and the Crack-up of Yugoslavia

If Czechoslovakia, Poland, and even Russia were faced with invasions of former German territories by Germans wielding not tanks, dive-bombers and heavy artillery but *Deutschmarks*, Yugoslavia was not so lucky. Yugoslavia soon succumbed to the rising tide of neo-fascist-inspired nationalism in the former Communist governments of Eastern Europe when a break-away Croatian Republic was proclaimed in the former capital of the Nazi-puppet Croatian Ustashi regime's capital, Zagreb. The breakup of that country, which the rest of the European Union in concert with the United States attempted to *prevent*, was aided, abetted, and finally realized by the actions of one nation – Germany -when that nation unilaterally recognized Croatia as an independent nation toward the end of 1991, scarcely two years after the reunification.⁴⁸

Despite the fact that the administration of President George Herbert Walker Bush charged Germany with contributing to the swiftly deteriorating conditions and escalating civil war in Yugoslavia, Germany openly defied Washington's protests and a United Nations arms embargo to the newly recognized country, supplying Croatia with almost "\$320 million of military hardware – including MiG fighter jets,⁴⁹ surface-to-air missiles, and late-model tanks."⁵⁰ Having created the Balkan crisis by its precipitous diplomatic unilateralism, Germany then cleverly hid behind the auspices of NATO as Croatia and other minority republics formed from the former Yugoslavia requested NATO assistance to fight the militarily superior Serbia, which was fighting, after all, for its own territory! Thus, under the official diplomatic protection of the NATO alliance, *Luftwaffe* fighter bombers and fighters flew patrols over Croatia and Bosnia, preventing the Serbian air force from even penetrating their air space. When Croatia requested German military personnel on its territory to enforce a peace accord between Croatia and Serbia in 1995, Germany only too readily agreed, and thus, for the first time since World War Two, the German military was deployed beyond the borders of Germany in significant numbers.⁵¹

7. *The First Post-Unification Chief of the Bundeswehr and the "Mobile Strike Force"*

Germany's diplomatic *and military* maneuvers in the wake of unification disclose a further little-known fact: not only the sheer size and strength of the *Bundeswehr*, but its ability to deploy *significant numbers* of troops outside of Germany on a moment's notice, a capability first suggested by the GSG-9 rescue of *Lufthansa* flight 181 and the alleged rescue of Andreas Strassmeir by the same elite team of commands deployed to the U.S.A. But that was the tip of the iceberg for the post-unification German army:

General Klaus Naumann, the first military chief of reunified Germany, sought to transform his army into an independent military power imbued "with a victor mentality."...Naumann was the driving force behind the *Bundeswehr's* revamped offensive strategy that entailed being "strategically alert rather than reactively averting war." Former German Fleet Admiral Elmar Schmälling publicly accused Naumann of preparing an army of aggression modeled after its Prussian predecessors.

The shift to an offensive military posture coincided with officially sanctioned efforts to reevaluate military performance during the Nazi period. Naumann insisted on modifying an old West German army decree that said a "linkage of the *Bundeswehr* to (Hitler's) *Wehrmacht* as an institution is impossible." Under Naumann's command, such a linkage was not only possible but desirable. The change in attitude was noted in *Europäische Sicherheit (European Security)*, a periodical closely associated with the German army, which spoke of "finding common ground, fairly, with our fathers' and grandfathers' generations, which in other nations is taken for granted." Henceforth, the *Bundeswehr* would not "separate itself from the roots which our founders from the *Wehrmacht* so painstakingly and with exemplary personal commitment sank in the earth, because these are roots which reach deep into the German past and German military history."

As part of its renewed emphasis on "tradition building," the *Bundeswehr* announced that the inclusion of all ranks (SS officers not excepted) on German military gravestones was an absolute necessity. This decision extended to war cemeteries in

central and Eastern Europe as well, according to General Naumann, who put it country simple: “Those East European states which have objected will have to have the thumbscrews put on them because they depend on us for large-scale economic assistance.”⁵²

General Naumann’s goals, however, were not limited merely to restoring symbolic traditions and connections to the Wehrmacht and the earlier imperial and Prussian armies.

It was Naumann who in fact pressured Bonn to send his troops to Croatia and Bosnia, to gain actual combat experience. It was an event that

marked a new phase in a gradual, step-by-step process orchestrated by German leaders to expand their influence across the Continent. Critics warned that the Bosnia assignment would open the door to future military intervention in other areas – *a development that Germany had prepared for by creating a highly mobile, 50,000-strong strike force capable of rapid deployment in any part of the world.*⁵³

Germany’s creation of this powerful strike force at the behest of General Naumann means that it once again has joined the select club of those military powers that can project and deploy large amounts of well-equipped, highly mobile, and competently led troops *anywhere* to enforce its will.

To reinforce this restoration of “old traditions,” on June 18, 1994, General Naumann’s *Bundeswehr* troops celebrated the final departure of British, French, American, and Russian troops from Berlin with a “Prussian-style torchlight parade in front of Berlin’s Brandenburg Gate;” it was a celebration to which the British, French, Americans, and Russians, were not invited by the German government.⁵⁴

But this was, really, nothing new. When Hitler’s favorite *Luftwaffe* ace, and a significant member of Bormann’s postwar Nazi

International, Hans Ulrich Rudel, finally died in 1982, over two thousand people attended his funeral, “many of whom paid their respects by stretching out a single arm and in unison bellowing the banned, pro-Nazi verses of ‘Deutschland über Alles.’”⁵⁵ As they did so, two *Luftwaffe* fighter jets flew over the site, dipping their wings low in salute of the former ace.

Rudel, as we shall see in the next section, was a prominent figure in the postwar corporate machinations of the Nazi International.



Former Luftwaffe Ace Hans Ulrich Rudel, During World War Two

D. Deep History and “Deep Politics”: Connecting the Dots

If the reader has had thus far that sinking, nausea-inducing uneasy feeling that “we’ve been here before, but what’s the connection?” then it is now time to connect a few more dots to make the postwar machinations of the Nazi International, German

reunification and its strangely “coincidental” parallel with Adolf Hitler’s own foreign policies a little clearer.

1. The New Corporate Ambassadors: Rudel and Skorzeny as Bormann’s Nazi Party Liaison Officers to Siemens and Krupp

It will be recalled that one of the mechanisms Bormann put into place in his postwar flight capital plan to maintain a powerful Nazi influence over postwar German corporations was a “liaison” officer inside various technical research institutes that German corporations were to establish in foreign countries. Two such liaison officers were undoubtedly *Luftwaffe* ace Hans Ulrich Rudel and SS commando and colonel Otto Skorzeny, both soldiers favorites of Hitler, and both ardent disciples and devotees of the Nazi cause. Skorzeny indeed served as a representative for the Krupp munitions firm and other German firms to Perón’s Argentina, negotiating lucrative contracts for German firms in that country.⁵⁶ Similarly, Rudel acted as a similar corporate ambassador for the giant German electrical firm of Siemens in Argentina, where Rudel made his home for years after the war. Other former Wehrmacht officers and Nazi bureaucrats found similar post-war employment: recall only the Egyptian escapades of Skorzeny, Voss, Remer, Schacht and others.

2. Gehlen: The Key Connection of the Scenario

But how was all this activity – including the sudden “populist” upwelling for German reunification and the simultaneous appearance of a “plan” for reunification in Kohl’s government, the rapid penetration of German economic influence into Eastern Europe, the funding of neo-Nazi “settlers” in former German territories, all accomplished? *How was Germany able to draw on resources behind the Iron Curtain and in the West to pull this off, with scarcely a peep from London, Paris, Moscow, or Washington?*

One need only consider the implications of the deal struck between Allen Dulles and Nazi military intelligence chief Reinhard Gehlen and the *subsequent history* of Gehlen’s organization to see how it could have been pulled off and planned well in advance

before the war's end. In the last chapter we already encountered the Nazi propaganda bureaucrat Grobbe, who worked his way up to become head of the Soviet Foreign Ministry's Arab affairs desk. Meanwhile, the CIA was employing Gehlen's spies, *many of whom were simultaneously members in the postwar neo-Nazi cells both in the eastern and western zones of Germany and Europe, organizations and cells that despised the United States.*⁵⁷ It is well-known that Gehlen's organization was deeply penetrated by the Soviet KGB, and that many of its agents were "turned" into double agents.

The trouble with double agents, of course, is that their loyalty is always in question, only in the case of Gehlen's organization, that loyalty never initially belonged to the United States at all; it belonged to Nazi Germany. It is thus quite possible that while the KGB *thought* it had "turned" many of Gehlen's agents *against the west*, those agents may have been able to pull off a convincing performance for their Soviet "masters" *because their real allegiance remained where it started: Nazism.*

If this scenario sounds implausible, consider *only the intelligence needs of the vast scenario of German reunification itself.* How did Kohl's government know that the Soviet Union, United States, Great Britain, and France, would not oppose his *unilateral* decision to press unification on East Germany? How did he know the populist uprisings in that country could be channeled into "popular demands" for reunification? For that matter, how did German industry penetrate *so quickly* into the strategic economic interests of an only very recently *Communist* Eastern Europe? How were neo-Nazi cells so quickly able to organize themselves, move into and buy former German lands in former German provinces in Poland and elsewhere? All this requires an *extensive* intelligence network and *lots* of money.

And if, as many researchers have proven, Gehlen's organization – the parent of the West German *Bundesnachrichten-dienst* – **was** so riddled with Soviet KGB moles, then imagine the nightmarish scenario that those "double" agents were in fact "*triple*" agents, taking orders neither from the West, nor the East, but ultimately playing both sides for fools in a careful and delicate and patient

dance, and taking their orders from the hidden directorate of the “Third Position”. At its height, Gehlen’s organization had more than four *thousand* agents inside of Eastern Europe and the Soviet Union, and it was the *de facto* nucleus of NATO intelligence itself, supplying almost “two thirds” of all of NATO’s intelligence on the Warsaw Pact.⁵⁸ To put it succinctly, the German BND was, and to a certain extent, *is* NATO intelligence.

If there is any doubt that this scenario has a high degree of probability, consider only this fact: when the Soviet Union collapsed, there was an outcry in the United States against the CIA, because it had *failed to predict* that a collapse was even imminent. But *West Germany, as is by now evident, was well-prepared not only for its own reunification with East Germany, but rapidly moved to exploit the situation in the former Warsaw Pact nations.* Was this really, therefore, a failure of American intelligence, or a failure of its German ally to share *all* the intelligence it had gathered from the descendent of Gehlen’s “KGB-mole-ridden” organization? If the Soviets were so effective at the manipulation of West German intelligence, why was West Germany the *only* “western” power *fully prepared* for the Soviet collapse?

There is historical precedent for this scenario.

It is now well-known that Gehlen’s organization, after the conclusion of the notorious deal with Allen Dulles that transformed it into the operational Soviet desk in the early days of the CIA, deliberately fed disinformation to the U.S.A. in order precisely to whip up American fears of Soviet military capabilities and intentions, and accordingly, *drive the American military build up and fan the fuels of an increasing debt load.* Martin A. Lee sums it up this way:

Was Gehlen merely improvising as he fabricated dire reports about Red Army machinations? Or was this part of a conscious effort to bind U.S. foreign policy to the Cold War for his own purposes? Gehlen’s strategy was based on a rudimentary equation – the colder the Cold War got, the more political space for Hitler’s heirs to maneuver. He realized that the Org could flourish only under Cold War conditions; *as an institution it was*

*therefore committed to perpetuating the Soviet-American conflict.*⁵⁹

If it was possible for Gehlen's "Org" to slip disinformation to the U.S.A., even if it came from "turned" Soviet double agents within his own network, by the same token, it would have been possible to slip the *Soviets* disinformation about *American* strength and intentions through the *same* "double" agents in the espionage version of the Nazi geopolitical "Third Position."

The strongest evidence that this scenario is exactly what happened is the fact that *Germany* was the *only* power in the world *fully* prepared to move quickly once the Soviet crackup finally came; such preparation requires accurate and detailed intelligence on the ground, organization, and financing. By co-opting anti-Communist bias in American intelligence that was beginning to emerge at the end of the Second World War, Gehlen's deal with Dulles effectively closed-down any potential de-nazification of postwar German intelligence and neutralized the potential threat posed by American intelligence. Thus, "by bankrolling Gehlen, the Agency had unknowingly laid itself open to manipulation by a foreign intelligence service that was riddled with Soviet spies."⁶⁰ While that may be true, it was also riddled at a much deeper level with Nazi agendas and intentions. Indeed, Martin Lee recognizes that this was the real purpose of the Organization to begin with, and the real motivation for the deal with Dulles, for the ultimate objective "of their subtly conceived efforts was the survival, *and ultimately the revival, of the Nazi movement.*"⁶¹ Gehlen and his *Bundesnachrichtendienst*, in other words, *were* an integral component in the machinery of Bormann's Nazi International, designed to gather information, and smuggle crucial personnel to safe havens in Latin America and the Middle East.

Thus, the manipulation of postwar circumstances began *even before the war ended, with the division of the technological spoils themselves*, for consider, when Otto Skorzeny began broadcasting public appeals for Germans and loyal Nazis to join him in the nonexistent National Redoubt,⁶² Allied intelligence was listening, and

accordingly, directed its armies southward to the Harz, the Austrian Alps, and Bohemian Czechoslovakia, where they found, not a redoubt, but lots of technical “goodies” including the scientists that made them.

In this, Allen Dulles and American intelligence were quite simply, and utterly, duped, for he

Continued to entertain a procession of Nazi raconteurs bearing misleading gifts. One of those who primed his pump was the wily SS Lieutenant Colonel Wilhelm (“Willi”) Höttl, who later acknowledged that he had hyped rumors of an impending bitter-end battle in the icy highlands. “Phony blueprints were drawn up and intelligence was leaked to the Americans, who seemed to be most prepared to believe such a romantic military plot,” Höttl recounted.⁶³

In other words, it was *German* military intelligence and psychological operations that were driving the American Third Army of General George S. Patton *straight for* the vast secret weapons treasure trove of General Hans Kammler, while simultaneously, German troops put up a fierce defense of Breslau in Silesia against the Russians, to allow time to get their *most highly* classified project, the Bell, safely away from Russian and Allied hands and out of Europe, and while Martin Bormann was manipulating his and Müller’s transfer to the U-234, and their safe passage to Spain under the cover of the security they knew would be accorded to the U-boat by an America which desperately needed its enriched uranium-235 and infrared proximity fuses for its own atom bomb.

The Nazi International had not only manipulated the conflict between Egypt and Israel, armed Egypt, arranged its alliance with the Soviet Union, trained the Grand Mufti’s fedayeen, armed Arafat, sold production facilities for weapons of mass destruction to Saddam Hussein, sponsored the “third positionism” of Juan Perón, hosted international terrorist summits in Nationalist Spain, but it had manipulated the end of World War Two and a clever division of technological spoils between the United States and the Soviet Union

while keeping “the really good stuff” for itself, driving each superpower into a financially bankrupting arms race; it had not only orchestrated the drive of General Patton’s Third Army into the very heart of Kammler’s secret research facilities, but its neo-Nazi descendants – if indeed they really are *neo-* and not just *plain old-* Nazis – had co-opted the populist uprisings in East Germany while West German intelligence conveniently gave Kohl’s government the green light for reunification....

...if this “coincidental” picture is not clear enough by now, then stop reading, and go no further, for the dialectical manipulation of conflict, the penetration into strategic industries in Europe as well as the unification of Europe itself under German dominance, prominent as all of these agendas were for the Nazi International, were nevertheless *not* the limits of its vision.

Those limits are represented by the Bell project, where it likely went, and what it implied about Nazi intentions and designs, for they were not merely confined to this world...

¹ Timothy Garton Ash, *In Europe’s Name* (New York: Random House, 1993), p. 406.

² Martin A. Lee, *The Beast Reawakens: Fascism’s Resurgence from Hitler’s Spymasters to Today’s Neo-Nazi Groups and Right-Wing Extremists* (New York: Routledge, 2000), p. 282.

³ “Brzezinski Backs NATO Expansion,” AP Online, December 7, 1997.

⁴ Conspiracy researcher Victor Thorn, however, has a slightly different version of these events at his website www.wingtv.net/elohim.html, p. 3 where he states that “Even more bizarre is the story of when Andreas’s Strassmeir’s station wagon was impounded by the Oklahoma Highway Patrol after he was pulled over for driving without tags or a valid license. Kenny Peace, a tow-truck driver from Muldrow, Oklahoma who yanked the vehicle, said that immediately after this event he started getting a flurry of calls from a Houston attorney, a general or major at Fort Bragg, North Carolina?, the Highway Patrol’s district office, the State Department, and the Governor’s office – all telling him to immediately release the vehicle. They also said that Andreas Strassmeir had full diplomatic immunity even though his visa had expired.”

⁵ See Martin A. Lee, *The Beast Reawakens*, p. 351. Lee does *not* mention, however, that Strassmeir was a graduate of the War Academy.

⁶ Martin A. Lee, *The Beast Reawakens*, pp. 352-353.

⁷ Lyon's own connections in this respect have been covered in a number of books and internet articles and studies. Martin A. Lee's *The Beast Reawakens*, pp. 339, 341-344, 346-347, 351-353, 361n, 362n contains valuable information about Lyons and remains, in this author's opinion, the best one-volume survey of Neo-Nazi and far right activities in this country and elsewhere. Several internet sources also provide information. According to one such source, http://truedemocracy.net/td2_1/Oklahoma/html, p. 4, Lyons "has been an attorney for neo-Nazi's (sic), Klansmen and Holocaust deniers, and has himself been videotaped participating in Neo-Nazi activities in Germany."

⁸ Victor Thorn, "The OKC-Elohim City Conenction," www.wingtv.net/elohim.html, p. 4.

⁹ Victor Thorn, "The OKC-Elohim City Conenction," www.wingtv.net/elohim.html, p. 4.

¹⁰ Martin A. Lee, *The Beast Reawakens*, p. 353.

¹¹ Martin A. Lee, *The Beast Reawakens*, p. 248.

¹² *Ibid.*, pp. 292-294. Lee notes that the American State Department "understood Kohl's indulgence toward openly revanchist groups as a calculated attempt to keep in check extremist elements that wanted to extend Germany's borders yet again" (p. 292). But it is difficult to see how Chancellor Kohl's attendance at one Silesian Expellee Society meeting, at which he spoke beneath a banner proclaiming "Patience, Silesia will be ours someday once again," can be seen as anything less than a political statement (for the subject of the deep financial and political involvement of such expellee societies in postwar German politics and their Nazi connections, see Martin A. Lee, *The New Right: Violent Extremism in Unified Germany and Beyond*. While an earlier book than Lee's *The Beast Reawakens*, it does go slightly more deeply into the issue of the expellee societies and Kohl's relationships to them.)

¹³ Lee, *op. cit.*, p. xxii.

- ¹⁴ Martin A. Lee, *The Beast Reawakens*, p. xxiii.
- ¹⁵ *Ibid.*, p. xxiv.
- ¹⁶ Martin A. Lee, *The Beast Reawakens*, p. 239.
- ¹⁷ Martin A. Lee, *The Beast Reawakens*, p. 239.
- ¹⁸ *Ibid.*
- ¹⁹ Martin A. Lee, *The Beast Reawakens*, p. 240.
- ²⁰ *Ibid.*, p. 273.
- ²¹ Martin A. Lee, *The Beast Reawakens*, pp. 273-275, 276.
- ²² Martin A. Lee, *The Beast Reawakens*, p. 275.
- ²³ *Ibid.*, p. 278.
- ²⁴ *Ibid.*, p. 280.
- ²⁵ *Ibid.*, p. 281.
- ²⁶ Martin A. Lee, *The Beast Reawakens*, p. 283., citing his personal interview with Douglas H. Jones, July 19, 1995.
- ²⁷ *Ibid.*, p. 284.
- ²⁸ Martin A. Lee, *The Beast Reawakens*, p. 284.
- ²⁹ *Ibid.*
- ³⁰ *Ibid.*
- ³¹ *Ibid.*
- ³² Martin A. Lee, *The Beast Reawakens*, p. 284.
- ³³ *Ibid.*, pp. 294-285.
- ³⁴ *Ibid.* Note the wording!
- ³⁵ *Ibid.*, p. 285.
- ³⁶ See my *Reich of the Black Sun*, pp. 35-43.
- ³⁷ Martin A. Lee, *The Beast Reawakens*, p. 250.
- ³⁸ The German and French influence in Hussein's archaeological projects raises other questions, not the least of which is that this influence has never been questioned or challenged or even adequately investigated. Michael Bogdanos, the American Marine colonel who led the U.S.'s official investigation of the Baghdad Museum looting, never once mentions in his popular account of the investigation, *The Thieves of Baghdad*, the explicit and specific catalogue of what the various expeditions in Iraq had uncovered, nor what Germany and France might actually know or have known about

the *non-* inventoried items at the museum. Perhaps he does not do so for reasons of security and the protection of priceless Iraqi national treasures that yet need to be recovered. But it is also entirely possible, despite his forensic competency and the quality of his recovery efforts in Iraq, that he does not know everything. In view of the Franco-German archaeological presence in the country prior to the Anglo-American invasion, certain obvious questions are raised about the potential hidden purposes of that presence as well as the potential hidden purposes of the Anglo-American invasion. And in the light of the context of the *political and economic* initiatives undertaken by Germany since the reunification, these questions only loom larger in importance.

Over the course of many radio interviews, people have asked this author what I have thought about the looting of the Baghdad Museum, and I have always responded that I thought aspects of it reflected an “inside” or “professional” job. This is a view equally shared by Bogdanos in his book. Bodganos, however, argues that the “insiders” and “professionals” were primarily art thieves intent upon making a killing in the lucrative black market antiquities trade. Some alternative researchers such as Jim Marrs have suggested that in fact the thieves may have been “our” insiders and professionals, intent upon stealing the secrets of lost technology and knowledge, and not intent upon merely selling the priceless artifacts on the international antiquities black market. But the pre-invasion heavy presence of French and German archaeological teams in the country coupled with the continued presence of the German BND in the country equally argues that it may have been someone *e/se’s* inside job. If indeed there were “hidden purposes” in play in the Anglo-American invasion beyond the publicly-stated concerns about Weapons of Mass Destruction and international terrorism, then someone *e/se’s* theft of uncatalogued Iraqi antiquities from the Baghdad Museum might be one of the hidden reasons for the continued Anglo-American occupation of the country. On this reading, both we, our British allies, and the Germans, are *still* looking for something in a quiet and covert “antiquities war.”

³⁹ Martin A. Lee, *The Beast Reawakens*, p. 251.

⁴⁰ Martin A. Lee, *The Beast Reawakens*, p. 293.

⁴¹ Martin A. Lee, *The Beast Reawakens*, p. 293.

⁴² Ibid.

⁴³ Ibid., p. 294.

⁴⁴ Martin A. Lee, *The Beast Reawakens*, p. 295.

⁴⁵ Ibid.

⁴⁶ Ibid.

⁴⁷ Martin A. Lee, *The Beast Reawakens*, p. 295.

⁴⁸ Ibid., p. 299.

⁴⁹ From the former East German airforce.

⁵⁰ Martin A. Lee, *The Beast Reawakens*, p. 299.

⁵¹ Ibid.

⁵² Martin A Lee, *The Beast Reawakens*, pp. 285-286

⁵³ Martin A. Lee, *The Beast Reawakens*, p. 300, emphasis added.

⁵⁴ Ibid., p. 386.

⁵⁵ Ibid., p. 199. This is an inaccuracy on Lee's part, and in fact, it is many people's perceptions of these verses of the German national anthem, though they are certainly *excusable* misperceptions. The verses were actually written before the Nazis took power, and, historically, were expressions of German national aspirations for a united nation. It was only after the Nazi regime took power and began its expansion that those verses acquired their sinister significance in modern perceptions.

⁵⁶ Martin A. Lee, *The Beast Reawakens*, pp. 109, 111.

⁵⁷ Martin A. Lee, *The Beast Reawakens*, p. xxviii.

⁵⁸ Martin A. Lee, *The Beast Reawakens*, p. 66.

⁵⁹ Martin A. Lee, *The Beast Reawakens*, p. 37, emphasis added.

⁶⁰ Ibid., p.39.

⁶¹ Ibid., p. 44.

⁶² Martin A. Lee, *The Beast Reawakens*, p. 24.

⁶³ Ibid., p. 25.

Part Three: The Development and Control of New Energy Technologies

*“This new ‘ritual coincidence,’ a second NASA mission **deliberately** landed on the day of Hitler’s birth, finally brought the astonishing set of alignments into crystal clear, sharp focus. For, by these repeated ‘ritual coincidences’ - commemorating the infamous leader of the Third Reich - the key players behind this entire NASA lunar ritual were now overwhelmingly identified as none other than the NASA members of the former Reich. NASA - at the highest levels - had effectively been ‘taken over’ from the Masons by Von Braun.”*

Richard C. Hoagland and Mike Bara,
Dark Mission: The Secret History of NASA,
p. 254.



“Don’t Cry for Me Argentina:” Doctor Ronald Richter and Perón’s Controlled Fusion Project at Huemul Island

“The theoretical concepts provided by Dr. Richter lack the necessary support to allow any hope of a successful realization of his purpose of maintaining and controlling a thermonuclear reaction. “
Dr. José Antonio Balseiro, 1952.¹

A. And Now, a Word from President Perón...

President and generalissimo Juan Domingo Perón was nothing if not intensely patriotic and flamboyant. His influence and effect on the development of Argentina as a regional power was lasting, and endures to such an extent that if one says “South American dictators” many people to this day think first of Perón. Few people realize, however, the depth of his relationship with the post-war Nazis or the degree of cooperation and funding he gave them. Even fewer people realize what some aspects of that cooperation and funding portended and revealed about the Nazi International’s postwar intentions and designs, for those intentions and designs were nothing less than *grand*.

On Monday, April 2, 1951, *Time* magazine ran an article called “Peron’s Atom.” The news was - pardoning the pun - nothing less than explosive, if true:

Juan Perón called his newsmen in last week for a very special announcement. With elaborate ostentation, members of the foreign press corps were barred. What he had to say, Perón explained, was only for his own people. His news: Argentine scientists, using only relatively cheap Argentine materials, had on Feb. 16 produced “controlled liberation of atomic energy,” i.e., an atomic explosion.

“The new Argentina,” explained Perón, had decided that it was not “worth the trouble to copy nuclear fission.” Instead, “contrary to what was done in foreign experiments, Argentine technicians worked on the basis of thermonuclear reactions, which are identical with those whereby the sun releases atomic energy.” The successful experiment had been conducted at the government atomic plant on Huemul Island, in the Andean lake of Naheul Huapi, some 900 miles southwest of Buenos Aires. It required neither uranium nor plutonium. “With the seriousness and veracity which is my custom,” Perón assured his people that his cut-rate atomic energy would be used “solely for power plants, smelters and other industrial establishments.”²

The generalissimo, it seemed, was after the power of the stars and of hydrogen bombs, the first of which would be detonated a little over a year after Perón’s announcement.

But then, in the very next paragraphs, the article went on to suggest a dark shadow casting a familiar and sinister swastika shape over the Argentine project, making it not so much Argentine, but Nazi:

Made in Argentina. At the President’s side was Dr. Ronald Richter, a plump, Austrian-born physicist (German University of Prague), who has been associated with Argentina’s atomic program ever since it was begun all of nine months ago.

Only nine months!?!? If so, then Dr. Richter had succeeded in a matter of a few weeks of moving Argentina from regional power to

the first thermonuclear power in the world! But more on this in a moment. The article continues:

Through an air force interpreter, the doctor announced in rich Austrian German: “What we have accomplished is strictly Argentine- it is infinitely superior to the system used in the U.S.... For some time now, Argentina has known the secret of the hydrogen bomb (but) I have always found a refusal on General Perón’s part to make use of this secret.”

Later, Dr. Richter answered a few questions. Just what kind of explosion had he achieved? “I control the explosion,” Richter replied loftily. “I can make it increase or diminish at my desire.” Could the explosion be heard at any distance? Well, said the doctor, that would depend on whether there was a storm at the time. Had it been heard at San Carlos de Bariloche 6 ½ miles away? No.³

Dr. Richter’s “controlled fusion explosion,” whatever it was, was showing the signs of a serious credibility problem.



Dr. Ronald Richter⁴

According to Richter's files at the U.S. National Archives and Records Administration, the *Washington Post* also weighed in with some heavy weight critics and skeptics, and some suspicions about Richter's possible Nazi background. In an article entitled "Peron is Irked by Atom 'Find' Disbelievers," the *Post* quotes Richter as stating "I want to make it clear that I was never a Nazi."⁵ But three days later the *Post* ran a short column that called into question Richter's anti-Nazi disclaimer:

Tried to Get Richter Into U.S., Engineer Says

SAN FRANCISCO, March 27 (1951) (U.P.). – Elmer G. Stahl, a utilities engineer, today said he knows Dr. Ronald W. Richter and tried to get him into the United States.

He said he learned of Richter, the Austrian-born scientist in charge of atomic experiments for Argentina, when he (Stahl) was a lieutenant colonel commanding the Steglitz section of Berlin after World War II.

"That was during the summer of 1945," Stahl said, "when the Russians and western Allies were competing fiercely for the German scientists they ran across. I heard about Dr. Richter, and picked him up.

"At that time Richter was willing to come to the United States and I tried hard to get him a visa. I wrote everybody from the President on down..."

He said he failed because the scientist had been a member of the Nazi Party. Richter then went to Argentina, Stahl said, and the two corresponded....⁶

Peron Is Irked By Atom 'Find' Disbelievers

Scientist Says He
Knows H-Bomb Secret,
Told Not to Make It

BUENOS AIRES, March 25 (AP).—President Peron, irked by doubts that Argentina had discovered a cheaper way to produce atomic energy, said today he is not interested in what the United States or any other country thinks.

Foreign reporters, however, were allowed to get a first-hand account of the discovery from Dr. Ronald Richter, the Austrian-born scientist who claims to have made it. The foreign reporters were excluded from yesterday's official announcement.

Peron said he made the announcement yesterday "not for other countries but for my country."

Richter, now an Argentine citizen, said he believed United States scientists are working on the same principle as his discovery and may have a similar discovery within their grasp.

The scientist said that although he had learned the secret of making the hydrogen bomb, Peron had ordered that it not be made.

"At the same time," he said, "we are not going to give away the secret nor the secret of our friends in the United States."

From Surprise to Ridicule

Numerous American and European scientists expressed everything from cautious surprise to outright ridicule of the Argentine claim. Some said it seemed merely an enlargement of predictions made in the last several years that the same reaction the sun uses to make heat—the same that would make a hydrogen bomb—may become a source of power.

American scientists agreed it may be possible to produce this reaction—fusion of two atoms to

See ATOM, Page 2, Column 3

Atom Doubts Irk Peron

make a new and larger atom—on a tiny laboratory scale. But none held hopes this could be extended to produce power.)

Richter insisted he had used neither uranium, tritium or plutonium—the materials used in nuclear fission—but had employed only materials native to Argentina.

(Scientists agree that the secret of the hydrogen bomb is no secret; that the problem is how to put one together so it will work.)

Richter added that Argentina is proceeding in the opposite direction from the United States.

"While they try to explode it (the hydrogen bomb)" he said, "we control it—energy is produced either way."

Richter said he came to Argentina in 1948. He said he worked in Berlin during the war on atomic weapons, but not on the official German uranium projects. In Goettingen, Germany, the atomic scientist, Dr. Otto Hahn, said he had never heard of Richter.

"I want to make it clear," Richter declared, "that I never was a Nazi."

The scientist said the "super" part of his secret was in maintaining temperatures of hundreds of millions of degrees to obtain the thermonuclear reaction. He said the whole aim of his experiments had been to get two light elements to merge together into a new element to produce energy.

He said the controlled explosion he had managed to produce was practically noiseless and took place in a "zone of reaction" of a kind of furnace surrounded by stone walls.

Richter said his zone of radioactivity following the explosion was small and he hoped to be able to avoid secondary radioactivity entirely. The experiment, he said, produced "enormous velocity of gases—a speed a 1000 times more than used to accelerate rocket bombs."

Atomic Claim 'Crazy,' U. S. Astronomer Says

By the United Press

An astronomer at the United States Naval Observatory said yesterday it is "absurd" to claim that an explosion can be produced on earth "equal to those registered in stars like novae."

Dispatches from Buenos Aires attributed the claim to Argentine Physicist Ronald Richter who was quoted as saying such explosions were achieved in the "reactors" being used in connection with Argentina's new "atomic energy project."

The observatory astronomer who declined use of his name said bluntly the claim is "crazy."

He pointed out that a novae (exploded star) releases energy roughly equivalent to that of 100,000 suns.

"An explosion even a tiny fraction as great as a novae would utterly destroy the earth," the astounded astronomer said.

March 25, 1951 Washington Post Article with Richter's Denials of Nazi Party Membership

In the light of the fact that the U.S. government brought over several Nazi scientists with a much more dubious past than Richter, Stahl's observation now seems naïve.

But there were weightier skeptics that were brought in to discredit Richter. In another article on March 25, 1951, in the *Washington Post*, none other than Drs. Werner Heisenberg and Otto Hahn – two of Nazi Germany's most famous atomic scientists – weighed in with their own carefully worded skepticism:

...Germany's two top atomic scientists termed the Argentine claim "fantastic."

Dr. Werner Heisenberg, Nobel Prize winner in physics in 1932 and now director of the Max Planck Institute at Goettingen, said in a telephone interview from Frankfurt:

"I do not believe that at the present time something new in atomic research has been developed in Argentina which United States scientists did not know long ago."

Atomic research in Argentina is only in its beginning and the country is training young scientists and building institutes, Heisenberg asserted.

Dr. Otto Hahn, president of the Max Planck Association, which carries on theoretical research in physics, agreed with Dr. Heisenberg. Hahn is another Nobel Prize winner, and received the award in 1944 for his work in chemistry.

Both said that no German atom scientists of whom they knew have emigrated to Argentina....[7](#)

In other words, neither Heisenberg nor Hahn had ever *heard* of Richter, an odd claim, since both allegedly worked on Germany's atom bomb. Even odder is why, in the face of the then well-established Allied Legend about German nuclear engineering incompetence, the word of two "atom bomb bunglers" such as Heisenberg and Hahn would carry any weight at all.

U. S. Nuclear Experts Doubt Peron Claim Of New Way of Controlling Atom Energy

Some top-ranking American scientists yesterday doubted President Peron's claim that Argentina has perfected a new way of releasing "controlled" atomic energy on a large scale.

They are Dr. Irma Lidel, chief nuclear physicist at the Office of Naval Research, Dr. Ralph Lapp, secretary of that office, and Dr. George Gamow, one of the first scientists to envision the possibilities of a hydrogen bomb.

President Peron of Argentina has claimed his scientists have developed the new technique by utilizing "thermonuclear reactions" like those going on in the sun. It is this type of reaction that would be used in the proposed American hydrogen bomb, utilizing an A-bomb as a trigger.

Dr. Lidel told a reporter that even if the H-bomb is perfected, it is improbable that the thermonuclear reaction could be used for the "controlled" release of atomic energy for practical, peacetime purposes on any scale other than a laboratory one.

Dr. Lapp said the story was self-incriminating on the face of it. "By definition, he pointed out, a 'thermal nuclear reaction' is one that must take place at such terrific rates that it is 'uncontrollable' and in the state, on earth, any such reaction could only be used as a destructive explosion for military purposes.

As for using materials other than uranium, Lapp noted that the United States had spent billions and had given up scores of thousands without finding any other elements as a starting point.

"I know, of course," he said, "what other material the Argentinians are using—it's deuterium."

Senator Dean, chairman of the United States Atomic Energy Committee, declined to make categorical comment on Argentina's atomic energy report. With a laugh, he said he supposed he would have to take Peron's statement literally to the effect that other countries didn't know what Argentina was doing.

Even other sources, persons in a position to know thoroughly the scientific aspects of the United States atomic project and to know as much as is available of what other countries are doing came to expressions of profound skepticism.

In the first place, they thought the idea of utilizing as atomic propulsion at this time without using uranium was beyond the bounds of credibility.

Secondly, they pointed out that

since the pace of atomic progress was atomic scientists in quality and quantity. In any order of countries that possess that indispensable factor, "Argentina is way down the list," one informed source said.

Dr. Gamow declared that on the evidence so far presented, the Argentinians report struck him like "advertising without goods."

He said it was conceivable that the Argentinians might have developed a new method for releasing atomic energy on a "microscopic" laboratory scale. But he added that it is another thing to do it on a practical scale.

Gamow pointed out that atomic energy was released in the laboratory by the great British scientist Rutherford as early as 1921, and that German scientists achieved another type of atomic-energy release in 1938. But he added that it remained for the American developments of the A-bomb years later to demonstrate the achievement on a practical scale.

It seemed apparent that the Peron announcement made at a news conference in Buenos Aires, would continue to provide a major topic of controversy for diplomats here for the opening of the Inter-American foreign minister's conference Monday.

There was speculation that the timing of Peron's announcement on the eve of the conference may have been deliberate—a political maneuver to increase his country's prestige and make it the focus of attention at the conference.

Almost all Latin American foreign ministers are on hand for the opening session.

Foreign Minister Alberto De-wings Campes of Uruguay, which neighbors Argentina, said he was surprised by the news and that he had no information.

Columbian Foreign Minister Gonzalo Estrero Jaramila shrugged his shoulders and said in a routine "Anything is possible under the sun."

Senator Edwin C. Johnson (D., Calif.) said he was "highly skeptical" of the report from Argentina. Johnson is a member of the Senate-Atomic Energy Committee, which usually is informed of all important atomic developments in this country and—as far as United States agents know about them—abroad.

"I am highly skeptical, but I hope that this report is true," Johnson, told a reporter after saying he had not heard of the claim previously.

Senator Millikin (R., Calif.), an-

other atomic commission member, agreed with Johnson.

(The United Press reported from Concord, Mass., that Dr. Walter G. Whitman, an adviser to the Atomic Energy Commission, said he was "highly skeptical.")

"You can't have an atomic explosion without uranium, I believe," said Dr. Whitman, who also is head of the chemical engineering department at Massachusetts Institute of Technology. "Peron's claim is very unlikely."

(The United Press also reported Gen. Leslie R. Groves, wartime head of the Manhattan atomic bomb project, as saying "It is theoretically possible to have an atomic explosion without the use of uranium.")

[At Berkeley, Calif., the noted University of California nuclear chemist, Dr. Glenn T. Seaborg, said:

"I don't know of any method of making atomic bombs without using uranium." Seaborg discovered plutonium, used in the first A-bomb.

Germany's top atomic scientists termed the Argentine claim "fantastic."

Dr. Werner Heisenberg, Nobel Prize winner in physics in 1932 and now director of the Max Planck Institute at Göttingen, said in a telephone interview from Frankfurt:

"I do not believe that at the present time something new in atomic research has been developed in Argentina which United States scientists did not know long ago."

Atomic research in Argentina is only in its beginning and the country is training young scientists and building institutes, Heisenberg asserted.

Dr. Otto Hahn, president of the Max Planck Association, which serves as theoretical adviser in physics, agreed with Dr. Heisenberg. Hahn is another Nobel Prize winner, and received the award in 1944 for his work in chemistry.

Hahn said that no German atom scientists of whom they knew have emigrated to Argentina.

Heisenberg said one of the researchers at the institute spent six months in Argentina and returned some time ago. He declined to identify him, but indicated the staff could hardly have resulted in any major new discoveries.

The only view of Peron's claim in his phrase "thermonuclear reaction."

However, thermonuclear has no specific meaning. It is a scientific

Washington Post
March 25, 1951

word to mean any and all kinds of atomic energy coming from the nucleus of an atom. So there is no information was wanted.

If Peron's announcement is correct, the scientists may have succeeded in releasing atomic energy by combining such common and lightweight elements as calcium, boron, lithium, beryllium and lithium. Argentina may have perfected an atomic reaction embodying the principle of the proposed hydrogen bomb, but involving a reaction of control that cannot be achieved with hydrogen. Senator Johnson pointed out that numerous German and Italian refugee scientists fled to Argentina during and after World War II, and many of these were supposed to have been active in atomic research.

March 25, 1951 Washington Post Article With Heisenberg's and Hahn's Claim Never to Have Heard of Richter

Of course, Richter's claims were fantastic on the face of it, for on the basis of the conventional physics of the day, of course, a thermonuclear explosion had to be triggered by an atom bomb, acting as a kind of nuclear "fuse" to attain the extreme pressures and heat gradients necessary to initiate a thermonuclear fusion reaction. Setting off even a "small" atom bomb to fire off a "small" hydrogen bomb would certainly have been a noisy event, easily hearable at the town of San Carlos de Bariloche which was, as the article itself offered, only 6 1/2 miles away.

Either Richter's explosion was so small, and brought about by completely unknown and off-the-books physics principles, or Richter was a fraud, and had defrauded the Perón regime. *Time* magazine opted for the latter:

Words & Baloney. While no one would deny that the Argentines might have produced some sort of laboratory-scale nuclear reaction, non-Argentine scientists were skeptical. "This is an interesting series of words," said an (Atomic Energy Commission) physicist, "but it means nothing to me." Said Dr. Ralph E. Lapp, onetime chief of the Office of Naval Research: "I know what that other material is that the Argentine's are using. It's baloney." Snapped Juan Perón: "I am not interested in what the U.S. or any other country thinks."

But Perón had cunningly timed his announcement to explode just as the foreign ministers of all 21 Latin American countries gathered in Washington in conference. If it did not convince them that there might be more than one atomic power in the hemisphere, it at least distracted them from the subject of the forced closing of *La Prensa* by Dictator Perón. As the delegates settled down this week to hammer out a hemisphere defense policy against Communist aggression, they kept one ear cocked for more offstage noises of Juan Perón.⁸

In other words, almost as soon as Perón and Richter made the announcement, it was being denounced in the United States by heavy hitters from its Atomic Energy Commission.

And given the nature of the claims themselves, who can blame them?

In any case, Perón, never one to let "the seriousness and veracity which was his custom" to go unchallenged, had nonetheless been publicly embarrassed by the American response, an embarrassment made all the more insufferable because Perón himself had obviously timed the announcement carefully in order to catch the conference's American hosts off guard and unprepared.

By this time, Perón had of course been privately consulting with his own scientists, who doubtless assured him that the American perspective on the matter represented sound science, and that something was, indeed, wrong with his atomic project in Bariloche. Determined to get to the bottom of the mystery, Perón appointed a commission to investigate the matter and report back to him personally.

And this, as they say, is where it gets *really interesting...*

B. The Argentine High Commission's Report and Dr. Richter's Strange Behavior

The members of this commission were two engineers,⁹ a Catholic priest from San Miguel observatory,¹⁰ and a "Captain Beninson," whose role, service branch, nationality, and role in the commission is otherwise unspecified in its final report. Heading up this committee was one Dr. José Antonio Balseiro, who at that time was a mere 32 years old, and who had to be recalled from England where he had gone to study nuclear physics.¹¹ As the official introductory note to Dr. Balseiro's report from the Argentine National Atomic Energy Commission states, "one of the conditions set out for the inspection was that the reports should be submitted individually."¹² President Perón, in other words, was taking no chances that there would be collusion among the commission members.

The result, as the official modern introduction to the report informs us, was that "the outcome of this inspection was the Commission, 1988, Nuclear Energy: History: Argentine: 621.039(091)(82), from the introduction. decision by the government to put an end to the project."¹³ But the official introduction continues with an intriguing set of comments: "A young unknown scientist (Dr. Balseiro) had to inform the Nation's President that he had been cheated: his personal assessment of Richter is so precise and deep as the technical report and at the same time gives a revealing and fascinating image of Balseiro."¹⁴ As far as the modern Argentine Nuclear Energy Commission is concerned, then, Dr. Balseiro's assessment of the project remained true: it was nothing but a swindle, and Dr. Richter was nothing but a clever con man.

But the report itself, and in Dr. Balseiro's own words to boot, calls into question this assessment. In order to see how, we shall present it in detail, compare it to the original *Time* magazine reportage of the story, and then examine the anomalous behavior that the report records.

Dr. Balseiro begins innocently enough:

To: The Most Excellent (Excelentísimo) President of the Nation, General of the Army, General (Don) Juan D. Perón.

I have the honor of presenting for the consideration of His Excellency the President, the report that has been requested from me about the *experiments witnessed during the visit carried out between 5 to 8 September of the current year (1952) to the Atomic Energy Plant of the Isla Huemul.*

I declare before His Excellency the president that the facts contained in this report are exactly as observed, that the interpretations and opinions rendered are faithful expressions of my honest understanding and knowledge, being expressed after detailed reflection and study.

I salute his Excellency the President with my highest esteem,

/s/

José A. Balseiro

Buenos Aires 15 September 1952.¹⁵

Let us pause and note some obvious things:

- 1) Dr. Balseiro actually *visited* the atomic laboratories of Dr. Richter and witnessed some experiments that were performed *over a year* after the initial announcement that was recorded in the *Time* magazine article;
- 2) The atomic facilities were located in the remote region of Bariloche in southwest Argentina, near the Chilean border in the foothills of the Andes mountains;
- 3) The facilities were furthermore located on the remote island of Huemul. In other words, someone wished to make sure that whatever research was being conducted, that it was being

conducted as far away from prying eyes as possible. This could mean that the research was either *fraudulent*, and that the fraud was being concealed by the project's remoteness, the view undertaken by the report, or it could mean that the research was highly covert and sensitive.

Finally, let us recall one more thing, from the *Time* magazine article:

- 4) The project head, Dr. Ronald Richter, was not Argentine at all, but *Austrian*, and was educated at the German University of Prague. Needless to say, *Time* magazine said *nothing whatsoever* about what this might portend.

With these points in mind, on to Dr. Balseiro's report itself. Balseiro begins his report by observing that "the basis upon which Dr. Richter's experiments rest are the two known nuclear reactions



That is, in the first case, the fusion of a lithium-7 atom with a hydrogen atom will produce two helium atoms plus an enormous quantity of electromagnetic energy (in the form of an x-ray and gamma ray burst) of 17.28 million electron volts of energy. In the second case, the fusion of two deuterium atoms (atoms of hydrogen with an extra neutron in the nucleus) will produce an atom of tritium (an atom of hydrogen with *two* extra neutrons in the nucleus) plus a free neutron plus a burst of electromagnetic energy of 3.18 million electron volts. So far, so good, the physics is straightforward.

After a page or two of equations and standard physical analysis, Dr. Balseiro cuts right to the heart of the matter. Dr. Richter, who claimed apparently to have achieved fusion reactions in a plasma via an intense electric arc, could not possibly have done so, for the physics – at least, in the conventional models demonstrably well-

known to Dr. Balseiro – simply could not and would not sustain such a reaction nor Dr. Richter’s claims:

For 1% of the nuclei to have enough energy to start the reaction, we need therefore, an initial temperature of at least 40 millions of degrees Kelvin. As a comparison, it is of relevance to recall that the temperature in the hottest zone of a voltaic discharge arc does not reach higher than 4,000 K and that the highest instantaneous temperatures reached in the laboratory by Kapitza are of the order of 100,000 K.¹⁷

In other words, by the standard model of thermonuclear fusion, where stars are gigantic hydrogen bombs in states of perpetual detonation due to their high gravity and heat gradients, and where the fusion chain reaction of a hydrogen bomb can only be set off by the extremely high heat of an atomic bomb explosion, Dr. Richter’s claims were like the later claims of Drs. Pons and Fleischmann to have achieved “cold” fusion reactions (again by employing relatively simple “electrolysis” equipment): the claims could not be true because the model of thermonuclear fusion known to standard physics made such claims and observations impossible.

1. Dr. Richter’s Claims to Have Found a New Principle of Physical, Nuclear Action

It is at this precise juncture that Dr. Balseiro introduces Dr. Richter’s actual claims. It is worth citing Balseiro in full, in order to appreciate the strangely synchronous connection to Pons and Fleischmann’s claims almost four decades later and the strangely parallel reactions of the scientific community to them:

The analysis made above, shows the impossibility, according to present knowledge, of achieving in the laboratory this type of nuclear reactions (sic). **Dr. Richter, however, claims on this point to have discovered a set of phenomena that make invalid the type of reasoning exposed above. Furthermore, he insists these new phenomena discovered by him,**

constitute the basic secret of the process of thermonuclear reaction.

It is not possible to foresee to what class of phenomena Dr. Richter refers to (sic), in particular because their existence cannot fail to contradict some of the basic knowledge which is accepted at present. In the first place, if the (Lithium-Hydrogen reaction) would occur at temperatures substantially below 20 (thousand electron volts) this would imply a fundamental change in our present knowledge of nuclear structure and quantum mechanics.¹⁸

These two paragraphs contain all the mystery that is the Huemul project, for there are only two logical ways to interpret the project and Dr. Richter's extraordinary claims.

The first is that Richter was, quite simply, a fraud at best or an incompetent who had misunderstood his laboratory experiments, or who was dealing with corrupted samples, at worst. If this sounds a bit like the reaction to Pons and Fleischmann, that's because it *is* almost exactly the same reaction! Dr. Balseiro, examining Richter's claims to have discovered and observed a new principle, rejects those claims and observations *as being contradictory to known scientific principles and theory*. And what upsets Balseiro is quite clear: if Richter *had* discovered such a principle it would upset a *great deal* of accepted principles of quantum mechanics.

But the second possibility is that Dr. Richter had indeed *found something*, something *not* explicable by the then (or even today's) standard theoretical models. It is indeed this *second* possibility that makes the interpretation of the remainder of Dr. Balseiro's report extremely interesting, for as we shall now see, some of Dr. Richter's and his associates' behavior are just downright inexplicable if indeed they thought they were perpetrating a fraud, or if indeed they are trying to *preserve* the project itself.

2. The Nature of the Principle: Precession

Just what principle had Dr. Richter allegedly discovered? According to Dr. Balseiro,

Dr. Richter has stated that the control device of the thermonuclear device is based on *the resonance obtained between the Larmor precession frequency – which originates in the interaction of the magnetic field acting on the intrinsic magnetic moment of the (lithium-7) atom – and that of the oscillating magnetic field produced by a radio frequency generator.* The figure given for the constant magnetic field intensity is 15,000 Gauss. On the other hand the device used by Dr. Richter does not produce the nuclear reaction in a vacuum but at atmospheric pressure. Under these conditions, and with the value of magnetic field that has been given, it is possible to show that the control mechanism, whatever its form, can not be achieved using the effect mentioned.¹⁹

Once again, after a couple of pages of very straightforward mathematics, Dr. Balseiro demonstrates the impossibilities of Richter's claims: "The result obtained," he concludes, "is that the enormous number of hits that the atom of (lithium) suffers at the operating conditions," i.e., under normal atmospheric conditions, "makes impossible any sort of control mechanism based on the principle mentioned by Dr. Richter."²⁰

3. Dr. Richter's Extremely Anomalous Behavior

But there was an even more fundamental problem with Dr. Richter's claims, and Balseiro minces no words explaining what it is:

Apart from the theoretical arguments mentioned, it is necessary to add that even though a radio-frequency generator exists inside the reaction chamber, *this has never been functional during the experimental demonstration.* Furthermore, apart from the electromagnet generating the constant magnetic field, *there is nowhere near the reaction area any device that could generate the oscillating magnetic field that might produce*

*a resonance with the Larmor precession frequency as Dr. Richter proposes.*²¹

In other words, Dr. Balseiro has now proposed an astonishing thing, and it is not the *last* time his report will document some extremely unusual behavior for scientists under the pressure of having to justify their research, for note what Dr. Balseiro's statements imply:

- 1) Dr. Richter and his associates either performed the "proof of concept" experiments for Dr. Balseiro's commission under circumstances when a vital piece of the equipment, the radio frequency generator, by Richter's own explanations of the principles of physics he believed to be involved, was either *broken down and not functioning at all*, or that he – Dr Richter – and his associates *failed to turn on*. In either case, *their behavior is inexplicable if they are faced with the survival of their project, for it guarantees that their experiments will fail, that they will be exposed as frauds, and that their funding will cease*.
- 2) Yet another vital piece of equipment – any device that could generate an oscillating magnetic field – was *completely absent* from the area and thus no "precession frequency," the very basis Dr. Richter had proposed as a theoretical explanation for whatever phenomenon he had discovered, could be generated!

In other words, if one piece of equipment was either malfunctioning or simply not turned on, one could perhaps rationalize Richter's and his team's behavior as a natural human oversight. But when yet another vital piece of equipment, necessary to the demonstration of the phenomenon for General Perón's inspectors is nowhere near the experiment itself, then the chances that Richter's behavior was accidental diminishes considerably.

Was the swindler trying to buy more time? Why would Richter have made a specific claim for a process that required such equipment, and then *not use it in performing the experiment for the*

*Argentine inspectors, thus guaranteeing the experiments would fail, and his project and its funding would be shut down? If the swindler was trying to buy more time, his behavior is decidedly counter to his purpose, since the experiments he *did* perform under these adverse conditions could hardly hope to satisfy the Argentine scientists and authorities. So, what was he doing? How does one rationalize Richter's extremely **odd** behavior?*

4. A New Anomaly and the Argentine Advisory Review Commission's own Anomalous Behavior

The mystery only deepens considerably as one reads further and further into Dr. Balseiro's report. Under the third header of his report, a section entitled "Experiments and checks performed," Dr. Balseiro records the following interesting exchange between the visiting Argentine scientists and commission members, and Dr. Richter:

The nuclear reaction of (lithium and hydrogen) produces two (alpha) particles with a mean energy of 8.5 (million electron volts). Since the reaction takes place, according to the device shown by Dr. Richter, in air at atmospheric pressure and in the region of the voltaic arc, the (alpha) particles must be stopped in the air, because their penetrating power at 8.5 MeV is only a few centimeters. It would be then, very difficult to verify that the nuclear reaction is actually produced by trying to determine if (alpha) particles are present. A possibility for such verification consists in identifying the presence of soft gamma radiation coming from the acceleration irradiation (*brehmstrahlung*) emitted when the (alpha) particles pass near the (hydrogen and oxygen) nuclei. Dr. Richter relies on Geiger counters for this purpose. When the device operates, these counters do actually record a large quantity of pulses. However, in the experiment carried out on Friday, September 5, a monitoring counter which the Advisory Review Commission took to the site, did not register the presence of any gamma radiation.

When confronted with this fact Dr. Richter suggested on the Saturday afternoon that during Sunday he would make

preparations so that on Monday morning he could perform the nuclear reaction ${}^2\text{H}+{}^2\text{H}+{}^3\text{He}+n$ with the purpose of verifying the presence through the use of foils that could be radiologically activated by these neutrons. Once the experiment was performed, there was no way in which the reaction could be verified; none of the foils was activated.

In view of this result it was asked of Dr. Richter that he repeat the experiment of the (lithium-7 and hydrogen) reaction performed.

The results of these new experiments were more than a little mystifying, for the normally confident Dr. Balseiro for once does not comment at any great length upon them. Here's what his report actually states:

The Advisory Review Commission had taken equipment to perform independent checks. Some of them were made before this last experiment. It was confirmed:

a) That the Geiger Counters which Dr. Richter has in the reaction chamber, in the way in which they are installed, are not sensitive to penetrating gamma radiation of a standard source of Radium.

In other words, Dr. Richter was once again either a swindler or an incompetent by installing his measurement equipment in such an irrational fashion, or, once again, his behavior is deliberately designed to make the experiment fail and cast the whole operation under suspicion. If the latter, then it is the *third* instance in which Dr. Richter's equipment was either malfunctioning, or deliberately placed in such a way it would do his experiments absolutely no good whatsoever!

Dr. Balseiro continues:

b) Only after removing the protective shielding present do they show a weak activity before this standard sample.

Note carefully what Balseiro has just actually said: *Dr. Richter placed his measuring equipment **behind** radioactive shielding where its role as a detector and verifier of his experiments would absolutely **be bound to fail***. If Dr. Richter was a swindler, then his behavior could hardly be more anomalous, for he is at every turn *trying to draw the Argentines' attention to the swindle!* The question is, *why?* And put yourself in *Juan Perón's* shoes for a moment, for while all of Dr. Balseiro's scientific learning and mathematics may have been lost on the generalissimo, Dr. Richter's strangely anomalous behavior would most definitely not have been lost to him; it would have stuck out like a sore thumb.

The report continues:

- c) The same source placed in the vicinity of the counters taken by the Review Commission produced a strong activity in them.
- d) That having the voltaic arc in operation while there were no Lithium salts or hydrogen and therefore being no possibility of the nuclear reaction to occur, the counters used by Dr. Richter showed a large activity.
- e) That with the device working under the conditions which Dr. Richter claims that produce the thermonuclear reaction, the response of the counters had the same characteristics than in the above case.
- f) The counters of the Advisory Commission in the cases d) and e) showed a weak activity. This without doubt comes from a penetrating radiation, as indicated by the fact that they worked also in the case specified as d).[22](#)

But what samples are being spoken of here? Is it radium that Dr. Richter had available? Radium that the Commission brought with it? Is the sample being tested in Richter's reaction chamber? Or is something else altogether, as suggested in case "d", at work?

Dr Balseiro, normally so careful and precise, is here for once very vague. And notably, even when there are *no lithium salts or hydrogen present* in the chamber, "the device working under the conditions which Dr. Richter claims that produce the thermonuclear

reaction, the response of the counters had the same characteristics,” namely, “a large activity.” Even the counters brought by the Advisory Commission showed “a weak activity.” Oddly, Dr. Balseiro, who could have written all these things off as simply “background radiation,” a standard explanation in such cases, did not do so. One was in the presence of a very real anomaly, and notably, the Commission *completely ignores it*.

And observe something else: Dr. Balseiro’s six-point commentary occurs *after* it was agreed that Richer would re-perform the lithium-7 and hydrogen fusion experiments. The presumptive explanation, then, is that the counter-readings referred to here in this section of the report may have been taken immediately after the lithium and hydrogen was pumped from the reaction chamber. The readings remained present when the presumed “thermonuclear source” for them was not. Yet another anomaly that is quietly passed over by the Advisory Review Commission and Dr. Balseiro. But this may be, as we shall eventually see, a very significant clue into what Dr. Richter was actually up to, and what his project was actually investigating.

5. The Heavy Water Production Facility and Odder Behavior from Dr Richter and His Team

The weirdest behavior exhibited by Dr. Richter and his team was recorded toward the end of the report, as the Argentine Commission drew near the end of its visit to Huemul Island near Bariloche. This occurred when “Dr. Richter showed a facility for the production of heavy water, which is in charge of Dr. Ehrenberg. He mentioned that in spite of its modest appearance great results have been obtained with it.”²³ Needless to say, the Argentine scientists asked the logical question, confronted by these claims. Dr. Balseiro records the strange behavior that occurred next with his customary exactitude:

When Dr. Ehrenberg was asked how they verify the successive enrichment of ordinary to heavy water, he answered that up to the moment no determination of the enrichment has been made, because they do not have a mass spectrometer,

and they have not made determinations by spectrographic methods or determined density variations.

Faced with such an absurd claim and the complete lack of any equipment that in fact could verify that any heavy water was being manufactured at all, Dr. Balseiro gave his customary, emphatic, assessment, one any logical scientist would have made:

Under these conditions it cannot be claimed that the setup actually functions for producing the enrichment of ordinary into heavy water.²⁴

Now, in addition to *Dr. Richter* deliberately drawing attention to malfunctioning, improperly positioned equipment, we also have his associate, *Dr. Ehrenberg*, *doing exactly the same thing*, this time in connection to a purported heavy water production facility, for it is Ehrenberg himself who points out to the Argentine Commission that the scientists have *no way whatsoever of determining if they are in fact producing heavy water since they lack the equipment to do so*. Why would Ehrenberg deliberately draw the attention of the Commission to this fact? Again, the behavior is not that of swindlers trying to evade exposure, for *they are exposing themselves*. Nor can their behavior be rationalized on the basis that they are trying deliberately to embarrass Perón's regime, for why slap the hand not only of the very government giving them and so many other former Nazis shelter from Allied war crimes tribunals or retribution, but also of the very government giving them so much financial largesse out of its own treasury?

In any case, following this series of disclosures, Dr. Balseiro then mentions, immediately after the heavy water facility is exposed, that Dr. Richter has other theoretical models in mind for explaining whatever phenomena he had observed:

Dr. Richter maintains that the thermonuclear reactor is a very powerful source of ultrasound. This is the reason he gave as an explanation for the 60cm thickness of the walls of the projected great reactor, whose construction has been interrupted due to

water leaks. Asked about what measurements have been made of the intensity and frequency spread of the ultrasonic flow when the reactor was working, he replied that none, *because they do not have the measuring instruments for the task. The reason why he knows of the existence of this intense ultrasound is no other than the physiological effects of tiredness and neuralgias produced by it. It is evident that without careful measurements of the ultrasonic flow, it is impossible to make a project for the great reactor, since there is a risk that protection from the ultrasound is ineffectual, or else to incur in a waste of material.*²⁵

Once again, having been told about a theoretical possibility of explanation, when queried further about his conceptions, Dr. Richter reveals that his team of scientists has no way of knowing whether or not the explanations are sustainable, because, like the heavy water facility, they have no measuring equipment to do so! For a scientist heading a project on which General Perón has lavished considerable sums from the Argentine national treasury, this is once again very odd behavior, for it draws attention to the fact that the scientists did not use those funds to purchase the very equipment necessary for the proper performance and monitoring of their facilities! And *they themselves* are drawing attention to this fact! While this strange behavior called forth no commentary or response from Balseiro or his associates, one may be reasonably confident that it would not have escaped someone like President Perón. All that Balseiro says of Richter and his behavior is to highlight its extremely anomalous nature in a series of remarks about it near the very end of his report:

It is important to point out as well, that Dr. Richter's way of handling matters leaves much to be desired with regard to scientific method.

(To say the least!)

In the attached report some examples have been mentioned to justify this opinion, however, they are not the only ones

witnessed.

My experience with people trained in the scientific method and with academic qualifications suggests to my mind, that the attitudes of Dr. Richter are far removed from what could be taken as the excentricities (sic) popularly attributed to men of science. To this I might add that in conversations with Dr. Richter over different subjects in physics he has shown either a surprising lack of knowledge for a person engaged in a project of such importance, or else very personal interpretations about well known and established physical phenomena.²⁶

But in any case, Balseiro concludes his report on a somewhat ambiguous note: “All the phenomena observed” in Bariloche province “bear no resemblance to nuclear phenomena.”²⁷ In other words, they had observed *something*; they just could not rationalize it on known scientific principles of nuclear reactions.

And that, indeed, was what Dr. Richter had been saying all along.

C. Richters' Replies and The Commission's Ripostes

As mentioned in the previous quotations, Dr. Balseiro attached another report on the end of his main report to President Perón. This addendum, entitled “Report on the Replies of Dr. Richter,” indicates that the Austro-German physicist did not disappear quietly into the night nor go without a fight, but rather, in yet another continuation of his anomalous behavior, “tried to save” his project by drawing ever more attention to its technical – and his own scientific – deficiencies!

This attachment begins innocently enough:

Dr. Richter claims that the general report (of this commission) is based on wrong assumptions when it affirms that the proton-lithium reaction can not be achieved when collision energies are well below 20 (thousand electron volts).

Indeed, we have already seen Dr. Balseiro's arguments, based on the sound physics of the day, that such reactions were well below

the extremes of energies and heat needed for thermonuclear reactions based on the standard model.

Dr. Balseiro continues:

(But) it is nonsense to pretend to use this possibility, whose yield is extremely small, as the basis of a physical process that involves a chain reaction. But even so, let us imagine that the reaction can be produced with an energy of 1 KeV. In order that 1% of the particles reaches such an energy, a temperature of *two millions degrees* is necessary. It can be seen, then, that even in this hypothetical case, for which no reaction can be expected, such a large temperature is necessary that its production escapes any technical possibility of being achieved. Imagine, therefore, what is the possibility of starting the nuclear reaction relying only on a voltaic arc whose maximum temperature, in the best conditions, does not reach 4000 degrees!²⁸

Richter, in other words, persisted in his claims that he was achieving controlled fusion reactions, and by doing so, was only highlighting the fact that such claims could not be sustained on the basis of standard science.

This, in fact, is what Dr. Balseiro concludes at the end of this section of his report to Perón:

The commission, when considering in detail the new declarations of Dr. Richter, and based in them, after analyzing the conclusions arrived at in the previous reports, has to point out that it cannot in any way modify the opinion reached in the general report, which reads:

“The theoretical concepts provided by Dr. Richter lack the necessary support to allow any hope of a successful realization of his purpose of maintaining and controlling a thermonuclear reaction. And furthermore,

“From the experiments carried out the Technical commission has not obtained any evidence that can justify in any way claims

of such a magnitude as those formulated by Dr. Richter, such as having achieved thermonuclear reactions, and of being able to maintain them and control them.”²⁹

In other words, Richter’s behavior remained curiously anomalous, since he persisted in his claims and theoretical explanations in spite of the overwhelming scientific case against them. Once again, Richter was acting almost as if he were deliberately trying to draw attention to those claims, and to the fraudulency of his project.

Curious behavior indeed for a scientist wanting to ensure a continued source of funding from Perón’s government!

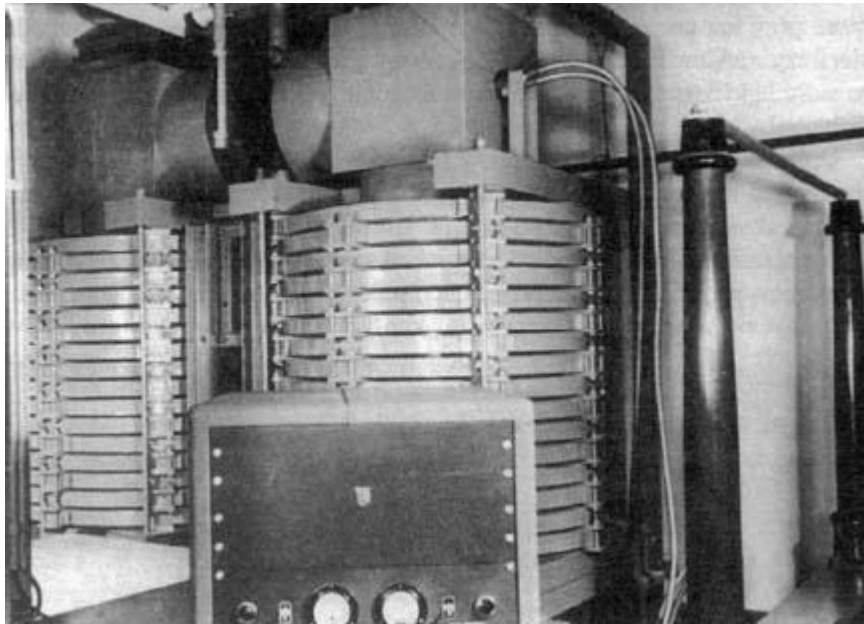

Some of Richter’s Equipment at Bariloche; Photo Courtesy of Igor Witkowski³⁰

There are two general ways of rationalizing Richter’s curious behavior: 1) his project was indeed fraudulent, and his behavior was that of an imposter playing out the charade to the very end, which is the standard view; or 2) that his project was really about something else, something indicated, perhaps, by Richter’s own theoretical explanations of what he was doing. In this case, it is possible that Richter was following instructions from “elsewhere” to shut the

project down by any means possible. If indeed Richter was involved in something entirely different, something *extremely sensitive*, then Perón's announcement to the Argentine Press could only have drawn attention to something that others did not wish known, and the only way to deflect that attention would be to have the whole thing declared a fraud. This latter possibility does indeed rationalize Richter's and his associates' behavior much better.

The only question that remains, then, is what exactly was Richter's team *doing*?



Huemul Island

¹ "Report on the replies of Dr. Richter," www.ib.edu.ar/informes-huemul/reports-huemul-principal.html, p. 9.

² No author stated. "Perón's Atom," *Time Magazine*, Monday April 2, 1951. www.time.com/time/magazine/article/0,9171,814503,00.html?promoid=googlep

³ No author stated. "Perón's Atom," *Time Magazine*, Monday April 2, 1951. www.time.com/time/magazine/article/0,9171,814503,00.html?promoid=googlep

⁴ Igor Witkowski, *Czwarta Rzesza: Poszukiwania Fortuny Nazistów* (Warsaw, 2005), p. 101.

⁵ No author, "Peron is Irked By Atom 'Find' Disbelievers: Scientist says He Know H-Bomb Secret, Told Not To Make It," *The*

Washington Post, March 26, 1951. Clipping found in Richter's file at the U.S. National Archives and Records Administration.

⁶ No author, "Tried to Get Richter Into U.S., Engineer Says," *The Washington Post*, March 28, 1951, emphasis added. Clipping from Richter's file at the U.S. National Archives and Records Administration.

⁷ No author, "U.S. Nuclear Experts Doubt Peron Claim of New Way of Controlling Atom Energy," *The Washington Post*, March 25, 1951.

⁸ Ibid.

⁹ Mario Bancora and Otto Gamba.

¹⁰ Fr. Juan Bussolini.

¹¹ "Report of Dr. José Antonio Balseiro Referring to the Inspection Carried out in Isla Huemul in September 1952," Buenos Aires: National Atomic Energy Commission, 1988, Nuclear Energy: History: Argentina: 621.039(091)(82), from the introduction.

¹² "Report of Dr. José Antonio Balseiro Referring to the Inspection Carried out in Isla Huemul in September 1952," Buenos Aires: National Atomic Energy

¹³ Ibid.

¹⁴ Ibid.

¹⁵ "Report of Dr. José Antonio Balseiro Referring to the Inspection Carried out in Isla Huemul in September 1952," Buenos Aires: National Atomic Energy Commission, 1988, Nuclear Energy: History: Argentina: 621.039(091)(82), www.ib.edu.ar/informes-huemul/reports-heumul-principal.html, pp. 1-2, emphasis added.

¹⁶ Dr. José A Balseiro, "Report About the Experiments of Dr. R. Richter, according to what was Witnessed by Me During the Visit made to the Atomic Energy plant at Isla Huemul, from 5 to 8 September 1952," www.ib.edu.ar/informes-huemul/reports-heumul-principal.html, p. 2.

¹⁷ Ibid., p. 3.

¹⁸ Dr. José A Balseiro, "Report About the Experiments of Dr. R. Richter, according to what was Witnessed by Me During the Visit made to the Atomic Energy plant at Isla Huemul, from 5 to 8

September 1952,” www.ib.edu.ar/informes-huemul/reports-heumul-principal.html, p. 3, boldface emphasis in the original, italicized emphasis added.

¹⁹ Dr. José A Balseiro, “Report About the Experiments of Dr. R. Richter, according to what was Witnessed by Me During the Visit made to the Atomic Energy plant at Isla Huemul, from 5 to 8 September 1952,” www.ib.edu.ar/informes-huemul/reports-heumul-principal.html, p. 4, emphasis added.

²⁰ Ibid., p. 5.

²¹ Ibid., emphasis added.

²² Dr. José A Balseiro, “Report About the Experiments of Dr. R. Richter, according to what was Witnessed by Me During the Visit made to the Atomic Energy plant at Isla Huemul, from 5 to 8 September 1952,” www.ib.edu.ar/informes-huemul/reports-heumul-principal.html, p. 6.

²³ Dr. José A Balseiro, “Report About the Experiments of Dr. R. Richter, according to what was Witnessed by Me During the Visit made to the Atomic Energy plant at Isla Huemul, from 5 to 8 September 1952,” www.ib.edu.ar/informes-huemul/reports-heumul-principal.html, p. 6.

²⁴ Dr. José A Balseiro, “Report About the Experiments of Dr. R. Richter, according to what was Witnessed by Me During the Visit made to the Atomic Energy plant at Isla Huemul, from 5 to 8 September 1952,” www.ib.edu.ar/informes-huemul/reports-heumul-principal.html, p. 6, emphasis in the original.

²⁵ Dr. José A Balseiro, “Report About the Experiments of Dr. R. Richter, according to what was Witnessed by Me During the Visit made to the Atomic Energy plant at Isla Huemul, from 5 to 8 September 1952,” www.ib.edu.ar/informes-huemul/reports-heumul-principal.html, p. 6, emphasis added.

²⁶ Dr. José A Balseiro, “Report About the Experiments of Dr. R. Richter, according to what was Witnessed by Me During the Visit made to the Atomic Energy plant at Isla Huemul, from 5 to 8 September 1952,” www.ib.edu.ar/informes-huemul/reports-heumul-principal.html, p. 7.

²⁷ Ibid.

²⁸ “Report on the Replies of Dr. Richter,” www.ib.edu.ar/informes-huemul/reports-huemul-principal.html, pp. 7-8, emphasis in the original.

²⁹ “Report on the Replies of Dr. Richter,” www.ib.edu.ar/informes-huemul/reports-huemul-principal.html, p. 9.

³⁰ Witkowski, *Czwrate Rzesza*, p. 101.

✠ 10 ✠

**“Balls, Bells, Bormann,
and Bariloche:”**

**A Speculative Reconstruction of Richter’s
Bariloche Fusion Project**

*“But there was another discovery made by Dr. Richter that
dwarfs
everything except, perhaps, controlled fusion. This discovery is
of
another and entirely different sort of energy whose discovery
also
resulted from Dr. Richter’s work on shock waves. Dr. Richter
even
coined a phrase for it, (although he is never given credit for
doing
so), and it is a term which we hear frequently now. It is called
‘Zero
Point Energy ‘.’”
Henry Stevens¹*

A. Perón Gets Help from a Bilderberger

One incident seldom mentioned in standard histories of Dr. Ronald Richter’s Bariloche Huemul fusion project casts a rather ominous shadow over the whole affair, and clearly calls into question the convenient explanations of standard science. This was the visit, to

Argentina, of the Dutch scientist Professor Cornelius Jan Bakker. Even more curiously, the incident was not revealed until a short article appeared in a *Time* magazine article after President Perón's investigative commission delivered the report that spelled the death knell for the project:

The Argentine government made a cagily indirect answer last week to reports that Juan Perón had arrested Ronald Richter, his "atomic scientist" (*Time*, May 28). Newspapers announced that Professor Richter and his laboratory associates would observe a national holiday by working 24 hours straight.

But Richter made no public appearance. Instead, Juan Perón issued a decree placing the entire Heumul Island atomic energy program under his own direction. *On top of that, Professor Cornelius Jan Bakker, a leading Dutch nuclear physicist, arrived at Huemul Island under a dense cloak of secrecy. He was apparently brought in as a result of recent talks between Perón and The Netherlands' good-will ambassador, Prince Bernhard.*

Was Bakker in Argentina to run a check on Dr. Richter? That was what Netherlanders surmised. Their theory: suspicious of Richter, but leary of getting involved with atomic experts from the U.S., Britain or Canada, Perón asked Prince Bernhard for a qualified Dutch scientist to audit Richter's books.²

Beyond this, the *Time* magazine article does not go.

But it does raise ominous questions.

Prince Bernhard of the Netherlands is perhaps best known for his role in the founding of the so-called Bilderberger Group. But there is a sinister side to Prince Bernhard:

Prince Bernhard originated meetings of the Bilderberg Group, a collection of world movers and shakers so secretive they have no proper name. Bernhard was a former member of the Nazi SS and an employee of Germany's I.G. Farben in Paris. In 1937, he married Princess Juliana of the Netherlands

and became a major shareholder and officer in Dutch Shell Oil, along with Britain's Lord Victor Rothschild.³

Many have written about the conspiratorial aspects of the shadowy Bilderberg Group, but few have noticed the ominous implications of its premier founder, Prince Bernhard, himself. As a native of Germany, and a member of the SS and employee of the notoriously powerful German chemical cartel, I.G. Farben, it is possible that the post-war founding of the Bilderberg Group is but another piece of the puzzle of post-war Nazi survival and the plans of the Nazi International. Succinctly, it is possible that the Bilderberg Group was created, in part, in order for the post-war Nazi International to monitor, penetrate, and influence the plans and machinations of one of their chief rivals for power: international corporatists and globalists. After all, the founder of the Group was himself a Nazi, an employee of I.G. Farben, and a member of the SS and therefore an adherent to its credo of loyalty and duty to the Party.

But whether or not that speculation be true, there is yet another ominous connection that Prince Bernhard's involvement may signify, and that is his connection to I.G. Farben, for it was Farben that built the notorious "Buna" synthetic rubber plant at Auschwitz, a plant that Carter Hydrick has cogently argued was in all likelihood a massive uranium enrichment facility, and that Richard C. Hoagland and I have argued may have even employed the exotic technology of laser isotope enrichment.⁴ In other words, with Prince Bernhard's I.G. Farben connection, we have a tenuous connection between Richter's Bariloche fusion project and the wartime atomic research of Nazi Germany.

With these revelations, Perón's consultation of a Dutch nuclear physicist assumes its ominous aspect, for having received a blunt denial of Richter's claims from his own scientists, Perón is appealing to a "former" Nazi, Prince Bernhard, for an audit of Richter's notebooks and claims. It is perhaps quite significant that it is after *this* audit that the project is supposedly shut down, for nothing appears to be forthcoming in the record about what Professor Bakker found, nor what he reported to Perón or Prince Bernhard.

And given Bernhard's SS background, we are permitted to assume that whatever *he* knew, the leaders of the Nazi International *also* knew. This fact now assumes great importance, as we discover the presence in Bariloche province of the most high ranking postwar Nazi of them all.

1. *And America's Little-Known Ambiguity toward Dr. Richter*

One author who has also noticed the strangely anomalous features of Dr. Richter's Bariloche project is long-time Nazi secret weapons researcher Henry Stevens. In his recent book *Hitler's Suppressed and Still-Secret Weapons, Science, and Technology*, Steven's notes that yet another researcher, the distinguished and late scientist Dr. Eugene Mallove – best known for his exposure of the shenanigans of “standard science” in dealing with the cold fusion controversy of the late 1980s and early 1990s, and founder of the magazine *Infinite Energy* – also noticed the oddities of the Richter affair:

Magnetic confinement fusion had a very strange beginning. Argentine dictator Juan Peron (sic, et passim) announced on March 24, 1951, that his country had mastered controlled fusion, bypassing completely the development of fission power that was then in vogue in various nations. Peron, a Germanophile, had set up an island laboratory for a certain obscure German scientist, Ronald Richter, who supposedly had brought the secret fusion work to fruition, or so headlines in the United States had allowed. The press was much less circumspect in those days about amazing scientific claims.⁵

As Stevens quips about the affair,

If we remember Dr. Richter today at all, it is not for his stunning achievements in physics, but for a press fiasco involving the Argentine leader Juan Peron in the 1950s. At this time, Richter was employed by Peron to do nuclear research and evidently had some promising results. Peron jumped ahead

of the research and pre-maturely announced that Argentina had bypassed fission power and had succeeded in producing fusion power.⁶

Sensing something extremely unusual about the whole affair, Stevens naturally decided to investigate with his customary diligence, and procured Richter's Paperclip file in a FOIA (Freedom of Information Act) request from the U.S. government, even though Richter never came to the U.S.A. as a part of the operation that brought "former" Nazi scientists into the country.

The files, according to Stevens, were nothing less than stunning:

Normally, a Paperclip file contains biographical and educational information about the particular scientist. It usually contains a description of his specialty as well as where he worked and who he worked for in Germany. There is a discussion of his alleged political leanings, which are always considered satisfactory. Then there is a background check, again politically motivated. Then, there are immigration details and perhaps which companies or government agencies which are interested in employing this individual. It is then up to the researcher to follow up these leads for additional information.

Sometimes, there is a description of actual work in Germany and actual hardware that was created, but this is rare. Also rare is any discussion about applications of his specialty in the United States or any proposed future research in the United States. *Dr. Richter's file is the big exception to all of this.*⁷

What precisely constituted the exception?

Behind the public controversy and standard science analysis of Richter that occasioned the controversy generated by Perón's press conference, the files told another story completely; they told of genuine though very hidden disagreement among the American scientists assessing Richter's viability as a potential Paperclip scientist:

From the Paperclip file, it (was) evident that the US government and its scientists given the job of investigating Dr. Richter were torn between two opposing poles. There were those who considered Dr. Richter a fraud...

...much like the official Argentine investigative committee did, and for obvious reasons of conventional scientific analysis. But, notes Stevens, the file also contains other types of evaluations:

There were those who openly admitted that they did not have the expertise to fully evaluate Dr. Richter and clearly wanted to take themselves out of the game of doing so. And there were those who recognized, even in 1957, that Dr. Richter “was working in 1970,” an understatement which can only now be appreciated.⁸

While Stevens does not cite many of the memoranda concerning the strange scientist, it would be worth doing so not only to uncover America’s peculiar inability to assess his value to its own black projects, but also to see how, long after official disinterest in his ideas was explicitly expressed , interest nonetheless continued. We shall refer to documents Stevens does not cite, for they are quite revealing.

The following document is typical of the ambiguous response to Richter in official U.S. Air Force papers:

CONFIDENTIAL

DEPARTMENT OF THE AIR FORCE
HEADQUARTERS UNITED STATES AIR FORCE
WASHINGTON 25, D.C.

AFDDC-SP-1
1956

21 November

SUBJECT: (U) Dr. Ronald Richter
TO: Director
Joint Intelligence Objectives Agency
Washington 25, D.C.

1. Reference is made to telecom between Col Geehan, JIOA and Capt James, AFDDC-SP-1.

2. It is the opinion of this office that the Air Force would not be interested in sponsoring Dr. Richter. However, your agency may wish to ascertain if other governmental agencies or private concerns would be interested in securing his services.

1 Incl
Memo to DCS/D
Fr Dir/Intell
Dtd 31 Jul 56
w/5 Incls

/s/ JOHN L. LOMBARDO
Lt Colonel, USAF
Deputy Asst for Special Projects
Office, Deputy Chief of Staff,
Development

 **CONFIDENTIAL**
DEPARTMENT OF THE AIR FORCE
HEADQUARTERS UNITED STATES AIR FORCE
WASHINGTON 25, D. C.

21 November 1956

AFDDC-SP-1

SUBJECT: (U) Dr. Ronald Richter

TO: Director
Joint Intelligence Objectives Agency
Washington 25, D.C.

1. Reference is made to telecom between Col Geehan, JIOA and Capt James, AFDDC-SP-1.

2. It is the opinion of this office that the Air Force would not be interested in sponsoring Dr. Richter. However, your agency may wish to ascertain if other governmental agencies or private concerns would be interested in securing his services.

1 Incl
Memo to DCS/D
fr Dir/Intell
dtd 31 Jul 56
w/5 Incls

John L. Lombardo
JOHN L. LOMBARDO
Lt Colonel, USAF
Deputy Asst for Special Projects
Office, Deputy Chief of Staff,
Development

CONFIDENTIAL

2587

DECLASSIFIED
AUTHORITY: 101-1
DATE: 10/15/2003

This letter was no doubt in response to a confidential "Air Intelligence Evaluation Record" dated May 8, 1956. The cover of this document states: "Directorate of Intelligence has investigated possibility of utilizing services of Dr. Richter and can offer no further encouragement." That rather blunt dismissal would seem to corroborate the claims of fraud and incompetence being advanced in the world media a few years earlier. But reading the three short paragraphs on the inside of the document tell a different, and once again very conflicted, story:

The program outlined by Dr. Richter is theoretically possible. Practically, it would involve setting up an experimental program costing money and effort far in excess of what Dr. Richter indicates in his paper. The questions to be solved concerning the materials and methods needed to achieve the results possible by his scheme far exceed the capability of present technical limitations.

Furthermore, Dr. Richter, although having developed a reputation for being a competent scientist in Europe, has in the last five years exhibited all of the characteristics of a first class mountebank and swindler. Under the Peron government he headed an atomic energy program which consumed large amounts of money under a cloud of secrecy. When financial exigencies dispelled the conspiratorial air around his program, his whole scheme "burst with the force of an exploding soap bubble," to quote one report on file at ATIC.⁹

Consequently, it is not reasonable to place very much reliance upon statements by Dr. Richter, in spite of the apparent technical soundness of his schemes.

It is requested, however, that all material of this nature available continue to be collected for evaluation.

The document is signed by a lieutenant colonel whose signature is unreadable.

JOINT MESSAGEFORM		SECURITY CLASSIFICATION				UNCLASSIFIED	
SPACE BELOW RESERVED FOR COMMUNICATION CENTER							
PRECEDENCE		TYPE MSG (ORIS)		ACCOUNTING SYMBOL	ORIG. OR REFERS TO	CLASSIFICATION OF REFERENCE	
ACTION	PRIORITY	ROTC	AVLT	AF	X		
INFO							
FROM: HQ USAF						SPECIAL INSTRUCTIONS	
TO: USAIRA BUENOS AIRES ARGENTINA							
<p>CONFIDENTIAL FROM AF01N-1A1</p> <p>Reurltr 119-R&D dtd 1 yr 57. Directorate of Intelligence has investigated possibility of utilizing services of Dr. Richter and can offer no further encouragement.</p>							
SYMBOL		SIGNATURE		DATE		TIME	
AF01N-1A1				APR 12 1957			
TYPED NAME AND TITLE (If recipient)		TYPED (or stamped) NAME AND TITLE		MONTH		YEAR	
Lt Col J. M. Copeland/hmf		CLIFFORD R. OFFER, CMC, USAF DIRECTORATE OF INTELLIGENCE					
PHONE 58618		PAGE 1		FORM 173		624	
SECURITY CLASSIFICATION		CONFIDENTIAL					

By Jon Lt Col Christopher, JCS

Cover of Air Intelligence Evaluation Record Indicating the US Air Force is Not Interested in Employing Richter

YIS # 276218

CONFIDENTIAL

SECURITY INFORMATION when filled in

AIR INTELLIGENCE EVALUATION RECORD

TO: Director of Intelligence Headquarters USAF ATTN: Collection Operations Div. Washington 25, D. C.	AIR INTELLIGENCE INFORMATION REPORT NUMBER IR-414-56 SOURCE OF REPORT (Air Attache, Command, etc.): Air Attache, Argentina INTELLIGENCE REPORT PARAGRAPH # (Name of officer): Fergil W. Hartog, Lt/Col USAF	DATED 8 May 56
USABILITY OF REPORT <input type="checkbox"/> EXCELLENT <input checked="" type="checkbox"/> SPECIFIC <input checked="" type="checkbox"/> USABLE <input type="checkbox"/> TOO GENERAL	VALIDITY OF INFORMATION <input type="checkbox"/> CONFIRMED <input type="checkbox"/> PROBABLY TRUE <input checked="" type="checkbox"/> POSSIBLY TRUE <input type="checkbox"/> SUSPICIOUS <input type="checkbox"/> CANNOT JUDGE	FULFILLMENT OF REQUIREMENT <input type="checkbox"/> COMPLETE <input type="checkbox"/> PARTIAL <input type="checkbox"/> SLIGHT
<p><small>Comments (flow the intelligence collectors involved. Your comments, guidance and criticisms are greatly appreciated. Definite and detailed evaluation will lead to improvement in the quality of intelligence reporting).</small></p> <p>The program outlined by Dr. Richter is theoretically possible. Practically, it would involve setting up an experimental program costing money and a fort far in excess of what Dr. Richter indicates in his paper. The questions to be solved concerning the materials and methods needed to achieve the results possible by his scheme far exceed the capability of present technical limitations. (CONF)</p> <p>Furthermore, Dr. Richter, although having developed a reputation for being a competent scientist in Europe, has in the last five years exhibited all of the characteristics of a first class mountebank and swindler. Under the Roman government he headed an atomic energy program which consumed large amounts of money under a cloud of secrecy. When financial exigencies dispelled the conspiratorial air around his program, his whole scheme "burst with the force of an exploding soap bubble" to quote one report on file at ATTC. (CONF)</p> <p>Consequently, it is not reasonable to place very much reliance upon statements by Dr. Richter, in spite of the apparent technical soundness of his schemes. (CONF)</p> <p>It is requested, however, that all material of this nature available continue to be collected for evaluation. (U.N.C.L.D.)</p>		
751-48100 Copy 111 <i>John P. R. Miller</i> Lt. John P. R. Miller		

FORM 122

May 6, 1956 Air Intelligence Evaluation Record of Richter

These three short paragraphs, after a cover indicating that the U.S. Air Force's complete disinterest in Richter's work, manage to do five things all at once:

- 1) Acknowledges the theoretical possibility of Richter's physics principles while simultaneously denouncing them as being far too expensive to research, and technically unfeasible given the state of technology in the mid-1950s;

- 2) Denounces Richter as a “first class mountebank and swindler,” implying that those very same principles are fraudulent;
- 3) Acknowledges Argentina had invested large amounts of money in an extremely secret project, implying that there was some legitimacy to his physics principles;
- 4) The project exploded with all the force and farce of an “exploding soap bubble,” implying the same principles are fraudulent once again;
- 5) And, to be on the safe side, the U.S. Air Force would continue to collect and quietly evaluate as much data on Richter and his work as it could.

Then, on the page immediately following these three amazing paragraphs there is the following cryptic comment: “It was learned that Professor Busemann (also one of Dr. Richter’s references) is familiar with Dr. Richter’s background and capabilities. Professor Busemann is now with the NACA.” What one of Dr. Richter’s “references” was doing working for NACA, the pre-cursor to NASA, the files never reveal, but immediately following this statement there is a handwritten comment: “Was he contacted?” One never learns, for the files lack any mention of contact with Dr. Busemann.

A little further down the same page, the “non-interested” Air Force gives its shopping list for what specific things in Dr. Richter’s work it is “not interested” in:

Specifically, This headquarters desires the following information:

- a. Technical data, diagrams, and plans concerning his experiments in Argentina and in Germany in 1943 (reference IR-76-56) with discussion of his problems and results.

CONFIDENTIAL

2/1tr fm AirA Argentina, 175-RAD, dtd 3 July 1956, subj: (U) Dr. Ronald Richter (See IR-76-56, 79-56, 80-56, and 145-56)

AFOPIN-1A1-11 1st Ind

Dept of the Air Force, Hq USAF, Washington 25, D. C.

TO: U. S. Air Attache, American Embassy, Buenos Aires, Argentina

1. This headquarters is directly interested in the work that has been done by Dr. Richter and in determining the availability of his services.

2. IN-76-56 (AF 718993) on Dr. Richter provides references who have known his work. One of his references in this document, Captain A. Berg, son, was contacted on 16 August 1956 to determine Dr. Richter's capability. During 1951, Captain Bergeson, who was then Naval Attache, in Argentina, made concerted effort to bring Dr. Richter to the U. S. to utilize his capabilities. In discussions with various German Scientists now in the WADC, it was learned that Professor Buesemann (also one of Dr. Richter's references) is familiar with Dr. Richter's background and capabilities. Professor Buesemann is now with the WACA. *WACA is reported to be*

3. Dr. Richter's work in Argentina should be reviewed by a competent specialist. The recommendation of Dr. Bell to interrogate Dr. Richter is occurred in. Specifically, this headquarters desires the following information:

a. Technical data, diagrams and plans concerning his experiments in Argentina and in Germany in 1943 (reference IR-76-56) with discussion of his problems and results.

b. Resume of his research activity, problems and results while at Berlin-Bukler-Waffen-und-Fahrzeugwerke during 1937/38 (reference IR-76-56).

4. This headquarters' interest in foreign activities in the nuclear field covered by Dr. Richter in Argentina requires the utilization of technically qualified persons. Should there be no interest in other government agencies or private industry for Dr. Richter's services, this headquarters would attempt to retain Dr. Richter, either in the U. S. if he can be permitted to enter, or in Argentina. Dr. Richter's evaluation of unclassified literature of various foreign nations in this field would be quite valuable considering his reported first hand experiences.

5. It is requested that this office be informed of developments in this matter citing control number A-2149.

BY ORDER OF THE CHIEF OF STAFF:

CONFIDENTIAL

CONFIDENTIAL

Air Intelligence Evaluation Record Indicating Interest in Richter's 1943 Research in Nazi Germany

b. Resume of his research activity, problems and results while at Berlin-Bukler-Waffen-und-Fahrzeugwerke during 1937/38 (reference IR-76-56).

After expressing all this specifically directed "disinterest," the document concludes by stating "Should there be no interest in other government agencies or private industry for Dr. Richter's services,

this headquarters would attempt to retain Dr. Richter, either in the U.S. if he can be permitted to enter, or in Argentina.”

What was it about Richter’s resume that had sparked this intense and specific interest from an Air Force going out of its way to feign disinterest? A glance at Richter’s own resume in the National Archives files, prepared at the request of the Americans is revealing.

But one of the secret American evaluations contains some bombshells, literally, and in Richter’s own words! I have organized the resume in table form for easier reading, and reproduce the actual documents following.

From – To	Employer	Position or Grade	Reason for Leaving
1936-1939	German University of Prague	In charge of the observatory	Thesis
1936-1939	Partnership with Dr. Hugo Apfelbeck (now Leoneb-Seegraben No. 47, Steiermark, Austria	Head of a research laboratory consultant	In 1939, Eberhardt died by accident, outbreak of World War II
1939-1940	Junkers Flugzeugwerke A.G., Dessau, Germany, Russian Zone	Head of a research laboratory under special research order	To improve position by working directly with the Air Ministry
1941-1943	Research Department LC1, German Air Ministry	Head of a research laboratory under special research order	To improve position by working directly with the Air Ministry
1943	Laboratorium Baron Manfred von Ardenne Berlin-Lichterfelde-Ost (US Sector)	Partly under research order of the Army Ordnance	See separate sheet no. 5 please

1943	Forschungslaboratorium, Allgemeine Elektricitäts- Gesellschaft (AEG) Berlin		See separate sheet No. 3 please
1943	Deutsche Versuchsanstalt für Luftfahrt, Berlin- Adlershof Germany, Russian Sector		Taking over research contract with AEG and Ruhrchemie Aktiengesellschaft
1944-1945	Allgemeinelektricitäts Gesellschaft (AEG) Berlin, research and production contract (royalties)	Head of a research laboratory consultant	When the war was over, I have been asking for cancellation of the contracts to leave Germany
1946	No contract, no employment, discussions with French scientists in Paris	Private research work	
1947	Discussions with scientists and industrialists in England and Holland	Private research work	
1957-1948	French Petroleum Institute 2, Rue de Lubeck, Paris XVI, France	Head of a research laboratory consultant royalty contract	Taking over nuclear reactor project in Argentina
1948-1950	Argentine Air Ministry, represented by the Instituto Aerotecnica at Cordoba	Head of a research laboratory consultant	Taking over project at Huemul Island
1950-1952	Under direct order of the then Argentine President	In charge of Project Huemul	Dismissed when the project became paralyzed for political reasons
1953-now	No contract, no employment, no exit permit when visas available, no visas when exit permit available	Private research under political terror	

DECLASSIFIED
Authority: AFR 100-10
Date: 11/15/2011

4. EMPLOYMENT AND MILITARY SERVICE:

From - To	Employer	Position or Grade	Reason for Leaving
1931	German University of Prague Geophysical Institute	in charge of the observatory	thesis
1936 - 1939	partnership with Dr. Hugo Apfelbeck (in ex Lechen-See- graben No.47, Steiermark, Austria) and Staatsrat Otto Eckhardt, represented by the Guhler Waffen- u. Fahrzeugwerke, Schl, Germany, Russian Zone,	head of a research laboratory consultant	in 1939, Eckhardt died by accident, outbreak of world war II
1939 - 1940	Junkers Flugzeugwerke A.G., Dessau, Germany, Russian Zone,	head of a research laboratory under special re- search order	to improve position by working directly with the Air Ministry
1941 - 1943	Research Department (L1), German Air Ministry	head of a research laboratory under special research order	see separate sheet No.5 please
1943	Laboratorium Baron Manfred von Ardeane Berlin-Lichterfelde-Ost (US Sector)	partly under research order of the Army Ord- nance	see separate sheet No.5 please
1943	Forschungslaboratorium, Allgemeine Elektrizitäts- Gesellschaft (AEG) Berlin,		see separate sheet No.5 please
1943	Deutsche Versuchsanstalt fuer Luftfahrt, Berlin-Adlershof Germany, Russian Sector		taking over re- search contract with AEG and Ruhrombie Aktiengesellschaft
1944 - 1945	Allgemeine Elektrizitäts- Gesellschaft (AEG) Berlin, research and production contract (royalties)	head of a research laboratory consultant	when the war was over, I have been asking for authorization of the Authority to leave Ger- many

APR 26 1999

First Page of Richter's Resume in the U.S. National Archives

OFFICIAL USE ONLY
(AFR 190-16)



Separate Sheet No. 2, Page 2.

From - To	Employer	Position or Grade	Reason for Leaving
1946	no contract, no employment, discussions with French scientists in Paris	private research work	
1947	discussions with scientists and industrialists in England and Holland	private research work	
1947 - 1948	French Petroleum Institute, 2, Rue de Laubeck, Paris XVI, France	head of a research laboratory consultant royalty contract	taking over nuclear reactor project in Argentina
1948 - 1950	Argentine Air Ministry, represented by the Instituto Aerotécnico at Córdoba	head of a research laboratory consultant	taking over project Humahuasi Island
1950 - 1952	under direct order of the then Argentine President	in charge of Project Humahuasi	dismissed when the project became paralyzed for political reasons
1953 - now	no contract, no employment, no exit permit when visas available, no visas when exit permit available, no military service	private research work under political terror	

DECLASSIFIED
Authority EO 12958

APR 26 1999

Chief, Declass Br
Dir. & Rec. Div, WHS

OFFICIAL USE ONLY
(AFR 190-16)

Second Page of Richter's Resume in the U.S. National Archives

Note that Richter leaves *completely blank* any summary in his resume of what specific research he was doing for the *Allgemeine Elektrizitäts Gesellschaft* or A.E.G. in Berlin. The significance of this omission will be seen toward the end of this chapter, but it is worth mentioning – for those who have not already noticed it – that the A.E.G. was the very firm that, under the direction of future NASA flight director Dr. Kurt Debus, built the power plant for the Bell.

As if that tenuous connection were not enough, Richter also supplied his potential American employers with a list of references

with their own impressive credentials:

Capt. A. H. Bergeson,
Suite 712 Cafritz Bldg.,
1625 Eye Street N.W.
Washington, D.C.,

Dr. Gordon Dean,
General Dynamics Corporation,
445 Park Avenue,
New York 22, N. Y.,

Dr. John A. Hall, Director,
Division of International Affairs,
United States Atomic Energy Commission,
1901 Constitution Avenue, N.W.
Washington 25, D.C.

Dr. Robert J. Hasterlick,
University of Chicago, c/o
United States Atomic Energy Commission,
1901 Constitution Avenue, N.W.,
Washington 25, D.C.,

Dr. Hans Multhopp,
The Glenn L. Martin Company,
Baltimore, 3, Maryland,

Lt. Col. Vergil N. Nestor,
Office of U.S. Air Attache,
United States Embassy,
Lima, Peru, South America,

Mr. Elmer G. Stahl,
1854 – 36th Avenue,
San Francisco 22,

Mr. Eugenio Lang,
127 South Westgate
Los Angeles 49, Calif

Note the heavy presence of representatives of the U.S. Atomic Energy Commission and key U.S. defense contractors. It is extremely unlikely that Richter the “mountebank and swindler” was dropping names, for it would have been an easy matter for the F.B.I. or even the Air Force’s own intelligence to contact these references.

Further reading of Richter’s file reveals the possible reasons for the Air Force’s “quietly disinterested interest,” for they contain some real bombshells.

2. Richter’s Paperclip File Air Intelligence Report Summary of His Wartime Research in Nazi Germany

The bombshells are in the Air Intelligence Report on the nature of Richter’s wartime research in Nazi Germany:

Research on the activation of catalysts, catalyst-controlled high-pressure coal hydrogenation and coal-cracking processes, *development of an image-converter-like activity-contrast-microscope, based on scanning of hydrogen or deuterium absorbing border surfaces by protons, deuterons, or electrons: for the first time, it became possible to see and to photograph activity contrasts which cannot be made visible by light nor by electron microscopes.* Activation of catalysts take place under continuously activity-controlled conditions. *Research work and design studies on electric arc furnaces systems, development of new types of arc plasma analyzing instruments and methods. In 1936, discovery of a plasma shock wave generating process, conception of a completely new type of industrial arc reactor system, based rather on plasma shock wave reactivity than on heat transfer. Development of a basis of operation for testing plasma shock wave conditions by means of plasma-collision-induced nuclear reactions.*¹⁰

All that is quite a mouthful, and indicates that Dr. Richter, whatever else might be said of him, was so far ahead of the conventional thinking of his Allied counterparts that it is small wonder many dismissed him and his work as a fraud.

A careful consideration of this passage will demonstrate why: for Richter, in order to *measure* the effects he was attempting to create and manipulate – *in 1936!* – was attempting quite literally to develop a microscope that could see *beyond* the limits of the electron microscope down into the very fabric of sub-atomic particles themselves,¹¹ and, from the assertions of the file summary, was allegedly successful to some extent, though, notes Stevens, at the time he was conducting this research, “he complains about the lack of measuring equipment that could withstand... high temperature stress.”¹² Small wonder then that in Argentina similar problems arose, since the Argentines were trying to use *standard* measuring equipment, and Dr. Richter certainly was not helping matters by his extraordinarily strange behavior!

But the real bombshells come at the end of the paragraph just cited, for Richter, be it noted, was apparently attempting to induce fusion in a plasma by means of electrical *stress*, and was attempting to develop a reactor for that purpose that would rely on shock waves, that is, *on internal standing longitudinal waves*, to achieve “plasma collisions,” i.e., fusion. While the description of the equipment here is broadly consistent with the descriptions of the Argentine investigative commission, what they missed is precisely the very advanced notion of plasma shock waves as being crucial to Dr. Richter’s conceptions.

Just how advanced *were* these ideas? As I noted in an article entitled “Does This Ring the Bell?” on my website,¹³ a very similar idea is being seriously proposed *in the beginning of the 21st century* by a corporation called General Fusion:

In an article on their website, General Fusion says it will “build a ~3 meter diameter spherical tank filled with liquid metal (lead-lithium mixture).” If this is beginning to sound a bit like the Nazi Bell device, hang on, it gets better, for this lead-lithium liquid metal mixture will then be “spun to open up a vertical cylindrical cavity in the center of the sphere (vortex).” At this point “two

spheromaks (magnetized plasma ‘smoke ring’) are injected from each end of the cavity. They merge in the center to form a single magnetized plasma target.” Does this ring the bell?

The parallels with the Nazi device are amazing. But then comes the disappointment. We are informed that this sphere is surrounded by steam driven metal pistons (no kidding!) which are accelerated to velocities of 50 meters per second. Impacting the outside of the sphere, they create a spherical shock wave which then drives through the liquid metal, eventually creating a strong shock wave as it nears the center and collapses the cavity of plasma. When this happens, “the conditions for fusion are briefly met” and a small burst of fast neutrons is created, which are then slowed down by the surrounding liquid metal which, of course, heats up the metal. “A heat exchanger transfers that heat to a standard steam cycle turbo-alternator to produce electricity...the lithium in the liquid metal finally absorbs the neutrons and produces tritium that is extracted and used as fuel for... subsequent shots.”¹⁴

In other words, some *seventy years* later an American company has hit on more or less the same idea: use of plasma shockwaves to induce controlled fusion. But note the crucial difference: in *Richter’s* version, an *electrical arc* is the shockwave inducer, in the *American* version it is steam-driven pistons inducing *acoustic* shock.

It begins to look not as if we are dealing with a fraud, but with a very brilliant man, decades ahead of his time. (But if so, again the nagging question, how does one rationalize his peculiar behavior as described by the Argentine investigative commission?)

In any case, Richter’s wartime biography becomes even more significant the further one presses into it. Stevens notes that Richter began to work for the research staff “of the Junkers Aircraft and Motor Works at Dessau, Germany” in 1939, with the outbreak of the war. “The Dessau facility for Junkers,” observes Stevens, “could be compared to the Skunk Works for Lockheed. Dessau was the facility for cutting edge research.”¹⁵

And just what sort of research was Dr. Richter doing at Dessau at Junkers' "Skunk Works"? He was working "on vibrational problems associated with supersonic aircraft,"¹⁶ that's what. And the allusion to America's super-secret Skunk Works and advanced aircraft black projects is more than a little suggestive, as we shall see shortly.

The reasons for Richter's involvement in this line of research are clear enough, for "he found that the instruments needed to do this could be used to benefit his shock wave research, which he obviously had not put aside."¹⁷

Then in 1942-1943 Richter's research takes another strange turn, as he "found himself at the Berlin-Lichterfelde-Ost facility" of German atom bomb scientist Baron Manfred Von Ardenne!¹⁸ Here it is worth citing the passage from Richter's own file that Stevens does not mention, for Richter's unusually vague language is significant for its omissions:

When in Berlin, I contacted Staatsrat Prof. Abraham Esau, then in charge of the German Nuclear Research Program, asking for a research job in this field. (I became acquainted with Prof. Esau in 1939, when he was visiting my research laboratory at the Suhler Waffenwerke. Since I was not much interested in joining the official uranium project, I at least accepted a contract with the Laboratorium Baron von Ardenne. Sort of 'personality clash' developed with the baron (he is now in Russia) and when I had to direct experimentation with a Van de Graff generator under direct order of the Army Ordnance, a few weeks later I was asked to resign (it was the Gestapo again – and the personality clash).

*Similar events happened when I took over a nuclear research job with the Forschungsinstitut of the AEG, Berlin. Three months later, I was kindly asked to resign (intervention of the Gestapo again).*¹⁹

For readers of my previous book on the subject, *Reich of the Black Sun*, that name will be ominously familiar, for it was Von Ardenne who in fact had perfected a method of using cyclotrons and mass spectrography separation tanks for the enrichment of uranium, one

of the technologies I believe to have been involved in the Auschwitz “Buna” plant, which in turn I believe, following Carter Hydrick, to have been a massive uranium enrichment facility!²⁰

Richter’s presence in Von Ardenne’s wing of the Nazi a-bomb project corroborates something else that I observed in that book, namely, that the Nazi atom bomb may have been seen by the Germans as but a gate to a much more destructive atomic weapon: the hydrogen bomb, since that bomb works precisely on the principle of nuclear fusion.

However, the significant thing to note is that Richter *left* Von Ardenne’s laboratory under Gestapo pressure, only to be reengaged in unspecified “nuclear” research for the A.E.G., when, again, he is relieved from that position, again by the Gestapo. The year, 1943, is significant, for that same year, Dr. Kurt Debus denounced a fellow Bell project A.E.G. engineer to the Gestapo, indicating that Richter may have been connected with the project.²¹

By 1944 and 1945, however, Richter found himself developing “light weight” batteries for the A.E.G. firm in Berlin. Nonetheless, “Richter found time to further his own work in arc plasma experiments using the large test installations available at the AEG transformer factories at Berlin-Oberschöneweide.”²² Here we encounter yet another indicator that Dr. Richter’s wartime research may have been more “connected” to Nazi Germany’s most sensitive research project – the Bell - than his apparently haphazard wanderings through various projects and German corporations at first glance suggests, but in order to understand that connection properly, we have to leap forward a bit, and examine the story from yet another point of view.

B. A Strange Presence in Bariloche After the Affair

1. A Look Around Bariloche

A glance around the environs of Bariloche, Argentina will show just how heavy the German influence there was (and is), for the architecture is distinctly German, from the houses to the hotels and *bierhausen*:



*German Style Houses in Bariloche*²³



*German Public Architecture in Bariloche:
Photo Courtesy of Sharkhunters www.sharkhunters.com*

There is even, in this remote, rugged, and beautiful place in Argentina, a German cultural center!²⁴

One of the biggest mysteries in Rio Negro province, however, was a large hotel, discovered by Sharkhunters founder Harry Cooper. Sharkhunters is an international group of veterans of the submarine services of World War Two, and in particular is dedicated to detailing the history of the *U-Bootwaffe* of the German *Kriegsmarine*. While on a visit to the Rio Negro province, Cooper found this large hotel, of distinctly German architecture, in a town so small that its mere presence is enough to raise eyebrows: “Why would anyone build such a magnificent hotel at such a little town so far away from other towns?” Cooper mused. Indeed, it was “Far away from *anything*.”²⁵ Built before and during the war, Cooper discovered that the hotel was the scene of gatherings of German veterans on April 20th every year, Adolf Hitler’s birthday. More importantly, according to people Cooper interviewed, General Eisenhower even visited the hotel sometime during or around 1954!²⁶ But that’s not all, for according to the people interviewed by Cooper, the motel was originally built as a large plastic surgery clinic!²⁷



The Lobby of the Plastic Surgery Clinic-cum-Hotel in the Area of Bariloche

*Photo Courtesy of Harry Cooper and Sharkhunters,
www.sharkhunters.com*

If all this be true, then one is able to conclude that the Bariloche area had become the new “Vatican” for postwar Nazis fleeing Europe, the headquarters of their covert projects, from providing new identities and faces to its “clients,” to conducting some very advanced scientific research.

There is only one conclusion that one may reach in the face of its architecture, its “guest services,” and the nature of the scientific research the Germans were conducting there:

The Nazi International was not only alive and well, but well-equipped, well-organized, and self-evidently well-funded.

2. Bariloche’s Prestigious Visitor-Resident(s)

Adding considerable weight to the idea that the environs of Bariloche had become something of a “headquarters” for the postwar Nazi International, and to the idea that Richter’s Huemul fusion project comprised something more than just an effort to control fusion, and that something else may have been going on in addition to that – something cleverly suggested and just as cleverly disguised by Richter’s “theoretical explanations” in terms of the actual physics being investigated is the alleged presence in Bariloche province *after*

the project was shut down of none other than the Nazi party *Reichsleiter* and the de facto leader of the postwar Nazi International, Martin Bormann.

Paul Manning, a journalist and long-time associate and friend of the famous CBS newsman Ed Morrow, mentioned Bormann's presence in Bariloche province, but did not connect his appearance with the Richter fusion project. Manning begins by noting that President Truman himself became involved in the hunt for Bormann in 1948, three long years *after* Bormann supposedly died trying to escape Berlin, according to the "official standard" history:

On June 16, 1948, President Truman became involved in the hunt for Martin Bormann. Robert H. Jackson, who had once taken a leave from the Supreme Court to serve as U.S. chief prosecutor at the Nuremberg trials, wrote to the president that a quiet search should be made by the FBI for Bormann in South America.

"My suggestion, therefore," he wrote, "is that the FBI be authorized to pursue thoroughly discreet inquiries of a preliminary nature in South America.... I have submitted this summary to Mr. Hoover and am authorized to say that it meets with his approval. You may inform him of your wishes directly or through me, as you prefer."²⁸

The choice of the FBI to do the investigation is perhaps significant. Under American federal law after Truman signed the National Security Act of 1947 that created the CIA and NSA, the FBI was restricted to intelligence operations on American soil. All operations on foreign soil fell under the jurisdiction of the CIA. So why would Jackson have urged President Truman to undertake an investigation in South America through the FBI? After all, Truman himself signed the law into existence and knew full well its contents.

The answer lies once again in the fact that the CIA, which under Zurich OSS station chief Allen Dulles during the war, had negotiated a highly secret deal with the head of German military intelligence on the Eastern Front, General Reinhard Gehlen, to turn over – lock, stock, and Nazi – Gehlen's entire network to the nominal oversight of

the American intelligence community, leaving Gehlen in charge of its actual day to day operations. In other words, before the ink was even dry on the National Security Act of 1947, the CIA's "civilian character" had already been compromised in the most egregious way, since its entire operational desk in Eastern Europe and the Soviet Union, and to a great extent elsewhere as well, was staffed by a network of Nazis! Needless to say, then, the CIA would not be the best instrumentality to investigate Bormann's possible presence in Latin America! Jackson's request also suggests something even darker: that both he and Truman *knew* of the extent of Nazi penetration of the CIA, and therefore of its untrustworthiness as an investigative agency for postwar Nazi activity.

In any case, as Manning observes,

The presidential authorization was given, and John Edgar Hoover assigned the investigation to his most experienced and skillful agent in South America, who proved that he was just that by eventually obtaining copies of the Martin Bormann file that were being held under strict secrecy by Argentina's Minister of the Interior in the Central de Intelligencia. When the file (now in my possession) was received at FBI headquarters, it revealed that the Reichsleiter had indeed been tracked for years. One report covered his whereabouts from 1948 to 1961, in Argentina, Paraguay, Brazil and Chile. *The file revealed that he had been banking under his own name from his office in Germany in Deutsche Bank of Buenos Aires since 1941; that he held one joint account with the Argentinian dictator Juan Perón, and on August 4,5, and 14, 1967, had written checks on demand accounts in First National City Bank (Overseas Division) of New York, The Chase Manhattan Bank, and Manufacturers Hanover Trust Co., all cleared through Deutsche Bank of Buenos Aires.*²⁹

Bormann's wartime contact with Deutsche Bank bigwig Dr. Hermann Abs, and the connections to the international financial interests of Morgan and Rockefeller via their big New York banks, was paying big dividends, for Bormann quite apparently did not even

have to *hide* his identity, but could sign and cash checks under his own name through some of the largest and most well-known banks in America as late as 1967!

But this is by no means all that the FBI's purloined Argentinian intelligence file contained. I cite the file completely, as contained in Manning's book, in order to demonstrate how thorough the Argentine security service's surveillance of Bormann was:

SPECIAL INFORMATION BULLETIN MARTIN BORMANN

German Nazi politician, born in 1900, in Halberstadt, Magdeburg, Germany. Titular head of the National Socialist Party. The Nuremberg War Crimes Tribunal sentenced him to death, along with other criminals of the Third Reich. *Came to Argentina in a clandestine manner, disguised as a Jesuit priest, arriving from Genoa, Italy, with false papers, around 1948.*

And with that, obviously, one has the Vatican connection to the postwar Nazi ratlines and escape routes from Europe, for in all likelihood, Bormann was traveling under a Vatican passport. Continuing with Manning's citation of the file:

1948

Bormann was seen and identified in the federal capital. (Information given by Doctor Pino Frezza, an Italian doctor who met Bormann *on an occasion when Bormann accompanied the Führer* – S.I.R. No. 0318.) Bormann made contact with a former German army officer at the ABC Brewery, at 500 Laval Street, in the federal capital. (S.I.R. 01319I. Juan Felisiak.)³⁰

Martin Bormann and Adolf Hitler were enjoying a nice outing in sunny Buenos Aires in 1948!? And what's more, not only the Argentines, but J. Edgar Hoover and in all likelihood Supreme Court Justice Robert Jackson and President Harry S. Truman knew all about it!

This prompts a question: why, if Justice Jackson, President Truman, and Hoover's FBI knew about Bormann's presence and movements in Latin America (not to mention the presence of Hitler himself!) were no efforts made to apprehend him – not to mention Hitler! - and carry out the sentence of execution handed down by the Nuremberg Tribunal? As Manning himself notes, "The CIA could have pulled aside the gray curtain that obscured Bormann – at any time. But the CIA and Müller's crack organization of former SS men found it to their mutual advantage to cooperate in many situations."³¹ That Bormann was allowed to continue banking *under his own name* with large American banks suggests a degree of high level protection and cooperation being extended to, *or coerced by*, Bormann from major American corporations.

At this juncture, it is worth noting that when Manning's book appeared, many readers questioned its whole basis, since Manning did not provide actual photocopies of the alleged Argentine documents he was citing. Of course, Ladislav Farago, who *did* provide pictures of the Argentine documents upon which he based his *Aftermath: Martin Bormann and the Fourth Reich*, received an equally dismissive treatment by American and British "establishment historians," who now claimed the documents were frauds.

Unfortunately for those "establishment historians," however, a recent book published a photocopy of a recently declassified FBI document to then director J. Edgar Hoover. Subject? The survival of Martin Bormann in Argentina. It makes some very interesting reading, for here is what it states:

Office Memorandum • UNITED STATES GOVERNMENT

TO: The Director TOP SECRET DATE: May 15, 1948
FROM: D.M. Ladd
SUBJECT: MARTIN BORMANN
War Criminal

Further reference is made to my memorandum of May 14, 1948, discussing the two intercepts received from Bureau Source Two in March of 1947, indicating that Martin Bormann is, in fact, still alive. SA³² S. W. Reynolds made inquiry at the War Department and ascertained the following:

The release of the two messages discussing Marin Bormann, as regular Source Two messages, caused a great flurry of excitement in British circles. *It appeared that the British were intercepting and decoding traffic over a clandestine network, a survivor of the German defeat, with ramifications in Europe and Germany.* The existence of this network was said to be a closely kept secret and the traffic intercepted was handled on an "eyes only" basis (i.e. for the use only of the officer to whom addressed) instead of the customary "top secret" basis on which Source Two material is handled. On the day these particular messages, dealing with Bormann, were received, the Army officer handling the "eyes only" traffic was away and the Navy got hold of the two messages. They were published as regular diplomatic traffic by the Navy. The State Department caused a number of photographs and descriptions of Bormann to be printed up and circulated among various embassies. State got considerable publicity for the allegation that Bormann was still alive. The British were, as usual, horrified at the lack of security. Their circuit apparently was broken up and the rumbling from the incident is still going on in the Army.

These intercepts, unless some very pointless deception was being engaged in, are a very close indication that Bormann is still alive. The British, apparently, are the only ones who have precise information about the network over which the clandestine traffic was moving. The furor caused by the above-mentioned incident apparently restrained the Army from inquiring into Bormann's whereabouts; CIA was not well set up at the time and the State Department's investigation was probably perfunctory. *It would thus seem that the British are the only ones who have any real information about the possible whereabouts of Bormann, as well as about the clandestine traffic concerning him. Because of the security consideration involved, it is necessary that the Bureau assume the posture that it has no information from Source Two on Bormann.* However, inquiry should be made of the British, and probably

could be made with some degree of success on the basis that persistent rumors are being received concerning Bormann.

There is attached a proposed memorandum to the Legal Attache of the American Embassy in London, containing a request that he contact available sources for any information which will throw light on the question whether Bormann is still alive and also specific identifying data including physical description, handwriting, fingerprints and photographs.

RECOMMENDATION: If you approve, it is suggested that the attached memorandum be forwarded to our representative in London.

FEC: pc

At the bottom of the document there is a stamp that reads "52 JUN 11 1946," followed by another "TOP SECRET" stamping, plus some handwriting notes after a check-mark that read "Yes & follow", with the following word indecipherable, and beneath that a handwritten "H" indicating that Hoover had approved the idea.

By this juncture, it is known what this clandestine radio network that the British were intercepting most likely was: it was Nazi Germany's extensive network of powerful transmitters scattered throughout Argentina and South America, the very network that Schellenberg turned over to Perón for Argentina's use³³

Office Memorandum • UNITED STATES GOVERNMENT

TO : The Director TOP SECRET DATE: May 15, 1948

FROM : D. M. Ladd

SUBJECT: MARTIN BORMANN
War Criminal

Further reference is made to my memorandum of May 14, 1948, discussing the two intercepts received from Bureau Source Two in March of 1947, indicating that Martin Bormann is, in fact, still alive. SA S. W. Reynolds made inquiry at the War Department and ascertained the following:

The release of the two messages discussing Martin Bormann, as regular Source Two messages, caused a great flurry of excitement in British circles. It appeared that the British were intercepting and decoding traffic over a clandestine network, a survivor of the German defeat, with ramifications in Europe and Germany. The existence of this network was said to be a closely kept secret and the traffic intercepted was handled on an "eyes only" basis (i.e. for the use only of the officer to whom addressed) instead of the customary "top secret" basis on which Source Two material is handled. On the day these particular messages, dealing with Bormann, were received, the Army officer handling the "eyes only" traffic was away and the Navy got hold of the two messages. They were published as regular diplomatic traffic by the Navy. The State Department caused a number of photographs and descriptions of Bormann to be printed up and circulated among various embassies. State got considerable publicity for the allegation that Bormann was still alive. The British were, as usual, horrified at the lack of security. Their circuit apparently was broken up and the rumbling from the incident is still going on in the Army.

These intercepts, unless some very pointed deception was being engaged in, are a very close indication that Bormann is still alive. The British, apparently, are the only ones who have precise information about the network over which the clandestine traffic was moving. The furor caused by the above-mentioned incident apparently restrained the Army from inquiring into Bormann's whereabouts; CIA was not well set up at the time and the State Department's investigation was probably perfunctory. It would thus seem that the British are the only ones who have any real information about the possible whereabouts of Bormann, as well as about the clandestine traffic concerning him. Because of the security consideration involved, it is necessary that the Bureau assume the posture that it has no information from Source Two on Bormann. However, inquiry should be made of the British, and probably could be made with some degree of success on the basis that persistent rumors are being received concerning Bormann.

There is attached a proposed memorandum to the Legal Attaché of the American Embassy in London, containing a request that he contact available sources for any information which will throw light on the question whether Bormann is still alive, and also specific identifying data including physical description, handwriting, fingerprints and photographs.

RECOMMENDATION: If you approve, it is suggested that the attached memorandum be forwarded to our representative in London.

TOP SECRET

JUN 11 1948

May 15, 1948 F.B.I. Document to Hoover³⁴

By this juncture, it is known what this clandestine radio network that the British were intercepting most likely was: it was Nazi Germany's extensive network of powerful transmitters scatted throughout Argentina and South America, the very network that Schellenberg turned over to Perón for Argentina's use!³⁵

The same Argentine intelligence file that Manning cites, however, also states that Bormann visited Bariloche once in the year 1956.³⁶ A second Argetine file, entitled "Special Information Bulletin Number

3,” similarly documents his escape from Genoa, Italy “with forged Vatican documentation.”³⁷ This same report goes on to mention Bormann’s presence in some interesting places in 1954:

At the end of 1954, Martin Bormann was seen in Mina Clavera, Córdoba, in the company of two men with Spanish surnames. He was calling himself José Pérez. He arrived at the hotel in Mina Clavero suffering from stomach problems and requested that the hotel manager bring him medicine for gastritis. One of his companions, named Jimenez, made a trip to Río Zeballos with the owner of the hotel. He took certain documents with him, and once there, he received documents for Martin Bormann-Pérez.

The hotel manager overheard some conversations, in which the names of the cities of *Bariloche (Argentina)*, *Valdivia (Chile)*, and *São Paulo (Brazil)* were mentioned.³⁸

A little further on, the same report notes that:

*In 1957, he was seen in the city of Bariloche, where again he was developing and coordinating Nazi activities.... From Bariloche, Bormann went to Valdivia, apparently to acquire a farm or to establish contact with a secret Nazi organization that operated in the south of Chile.*³⁹

But what Nazi activities were left for Bormann himself to coordinate in Bariloche, when the *only known* Nazi activities ever centered there were precisely Dr. Richter’s “controlled fusion” project for Perón, and since Perón had long since ostensibly closed the project down?

Bormann did much more, however, than merely *visit* Bariloche after the Huemul-Richter affair. It was, until Perón’s ouster from power in 1955, his *headquarters*, for as Manning notes, he had moved to a 5,000 acre cattle and sheep ranch “about 60 miles south of San Carlos de Bariloche” where he remained until Perón was overthrown.⁴⁰

Bormann had bunkered down, in other words, very close to the center of an ongoing postwar Nazi atomic research project *of some unknown nature*, and that fact highlights the possibility that the project was extremely important and sensitive to the postwar Nazi International, and that it required a source and amounts of funding *other* than Perón which only Bormann could provide.

So what do we have?

- 1) Bormann's headquarters in Argentina was a large ranch in the same environs near Bariloche where Dr. Ronald Richter's "fusion project" was located;
- 2) Bormann's possible presence near Bariloche throughout the Huemul affair and the Argentine investigation commission's visits also provides yet another rationalization for Dr. Richter's curious behavior, for it makes that behavior very likely something *contrived* and performed under direct orders from Nazi higher-ups, if not even Bormann himself, *not so much to shut the project down, but to close off Argentine involvement with it, and to cloak its real purpose by discrediting it in the world's eyes*;
- 3) After Perón's overthrow, Bormann returned to Bariloche to "coordinate Nazi activities" there, suggesting *some sort of project continued there, independent of the Argentine government*.

Consequently, the following questions assume great significance: *What were Dr Richter and the German scientists really doing at Huemul? What obscure scientific principles were they investigating?* The clues, once again, are afforded by Dr. Richter himself, and a tapestry of little noticed corporate relationships, Richter's Paperclip file, and what is already known about the Third Reich's most highly classified secret weapons project.

C. Dr. Richter's Theoretical Explanations

1. The Origins of the Huemul Project: Gerlach and Diebner

So let us return to Dr. Richter's theoretical explanations, as recounted by the Argentine investigative commission's reports, and

dig deeper, interpreting them along the lines his behavior itself suggested: that he was being ordered by his Nazi bosses to publicly discredit the project in order to sever it from Argentine influence, and remove it from public scrutiny. Accordingly, Dr. Richter's remarks have to be unpacked carefully, for as a result of this interpretation, he both simultaneously revealed and concealed, that is, he deliberately *misled* Argentine authorities as to the exact nature of his research and its theoretical foundations, so that it would lead to a dead end on conventional scientific analysis, and he deliberately *revealed*, in a general way, the basic ideas he was exploring, knowing full well that they would not be understood by conventionally minded scientists.

With this in mind it is interesting to note that at least one source thought there was more to Dr. Richter than an incompetent at worst, or con man at best. Citing the recent work of German researcher Professor Rainer Karlsch, the well-known online encyclopedia, Wikipedia, provides the following highly illuminating bit of background information concerning Richter's Huemul project:

During World War II German scientists under Walther Gerlach and Kurt Diebner carried out experiments to explore the possibility of inducing thermonuclear reactions in deuterium using high explosive-driven convergent shockwaves, following Guderley's famous convergent shockwave solution.

In other words, as I have long maintained throughout my Nazi secret weapons books and in numerous interviews, the Nazis were, at the minimum, after a *clean hydrogen bomb*, and that implies they were after a very different *physics* than has become the standard "public consumption" physics in the West.⁴¹

At the same time Richter proposed in a memorandum to German government officials the induction of nuclear fusion through shock waves *by high-velocity particles shot in to a highly compressed deuterium plasma* contained in an ordinary uranium vessel. The proposal was not carried through.⁴²

The article goes on to note that Richter's claim to have achieved controllable fusion was wrong on any conventional scientific analysis, though it also notes that "it is hard at present to analyze his ideas because he never published them in the peer reviewed literature."⁴³

But the summary of Karlsch's research is indicator enough of the connection – the *real* connection, and the real physics Richter may have been involved with - for the mention of Dr. Walther Gerlach, project head of the Nazi Bell, and Dr. Kurt Diebner, is enough to permit speculation, coupled with Richter's own double-edged theoretical clues. As we shall see, this connection reveals a weaponization potential far beyond mere atom bombs, or for that matter, mere hydrogen bombs.

2. Richter's Conceptions and American Interest

a. His Conceptions as Recorded by the Argentine Investigative Commission

Let us recall, from the previous chapter, what theoretical basis Dr. Richter maintained his work was based upon.

As Dr. Balseiro noted in his report to President Perón,

Dr. Richter has stated that the control device of the thermonuclear device is based on *the resonance obtained between the Larmor precession frequency – which originates in the interaction of the magnetic field acting on the intrinsic magnetic moment of the (lithium-7) atom – and that of the oscillating magnetic field produced by a radio frequency generator*⁴⁴

Additionally, Balseiro noted that much of the key equipment Dr. Richter used was not even functioning during his demonstrations for the Argentine commission:

Apart from the theoretical arguments mentioned, it is necessary to add that even though a radio-frequency generator exists inside the reaction chamber, *this has never been*

functional during the experimental demonstration. Furthermore, apart from the electromagnet generating the constant magnetic field, *there is nowhere near the reaction area any device that could generate the oscillating magnetic field that might produce a resonance with the Larmor precession frequency as Dr. Richter proposes.*⁴⁵

So what do we have?

Let us look a little closer. According to the Argentine investigative commission, Richter claimed that the following mechanism might induce controllable fusion:

- 1) *precession within a plasma*, that is, the plasma was put into a state of *rotation* where a “wobble,” like the precession or “wobble” of the earth around its axis of rotation, or like a toy gyroscope begins to “wobble” when it slows down, is occurring.

But note also that Dr. Balseiro indicated that Richter had radio frequency generators, as well as some unused and unspecified electromagnetic equipment present. This implies that

- 2) the radio frequency generator was used to oscillate and rotate the plasma; and that
- 3) magnetic containment and rotation may also have been employed; and that,
- 4) the radio frequency generator may have been used to *pulse* the plasma, to create standing “shock waves” within it.

With these observations, we are now in the presence of a new mystery regarding what Dr. Richter was up to, and in order to appreciate that mystery in the fullness of its implications, we have to journey to America.

b. Richter’s Paperclip File and American Ambiguity

As already mentioned, it was researcher Henry Stevens who once again uncovered a veritable goldmine of information concerning Dr. Ronald Richter in the American National Archives and Records Administration (NARA), information that throws the whole public story of his Huemul fusion project into a cocked hat, and reveals it to be most likely a carefully scripted effort to debunk his research and remove it from the public scrutiny that Perón's premature press conference had drawn to it. Stevens revealed his research and the considerable American interest in Dr. Richter in his latest book, *Hitler's Suppressed and Still-Secret Weapons, Science, and Technology*. As already noted, as Stevens summarized Richter's Paperclip file, it soon became evident

That the US Government and its scientists given the job of investigating Dr. Richter were torn between two opposing poles. There were those who considered Dr. Richter a fraud. There were those who openly admitted that they did not have the expertise to fully evaluate Dr. Richter and clearly wanted to take themselves out of the game of doing so. And there were those who recognized, even in 1957, that Dr. Richter "was working in 1970", an understatement which can only now be appreciated.⁴⁶

Just what did the U.S. government's files on Dr. Richter have to say that could have solicited such a wide range of responses?

Once again, a glance at the summary of his research work as given in the Air Intelligence Report of his Paperclip file reveals the vast extent of his experimentation, and of his conceptual grasp of what was involved:

Research on the activation of catalysts, catalyst-controlled high-pressure coal hydrogenation and coal cracking processes, *development of an image-converter-like activity-contract-microscope, based on scanning of hydrogen or deuterium absorbing border surfaces by protons, deuterons, or electrons: for the first time it became possible to see and to photograph activity contrasts which cannot be made visible by light nor by electron microscopes.* Activation of catalysts take place under

continuously activity-controlled conditions. Research work and design studies on electric arc furnaces systems, development of new types of arc plasma analyzing instruments and methods. *In 1936, discovery of a plasma shock wave generating process, conception of a completely new type of industrial arc reactor system, based rather on plasma shock wave reactivity than on heat transfer. Development of a basis of operation for testing plasma shock wave conditions by means of plasma-collision-induced nuclear reactions.*⁴⁷

Observe carefully what the Air Intelligence Report summary is actually saying here:

- 1) Richter had discovered plasma shock waves in 1936, and something in the discovery convinced him that shock waves might be a way to induce “plasma-collision-induced nuclear reactions,” which is a convenient euphemism for “controlled fusion.” If so, then it is easy to see why the Nazi Reich had such an extreme interest in his work, for if fusion could be induced in a plasma by means of shock waves and controlled, then it was also conceivable that an *uncontrolled* fusion chain reaction could be so induced, and thus one would have a “clean hydrogen bomb,” a weapon of great destructiveness, without the need of an atom bomb to set one off. But more significantly, Richter was up to something else, and apparently quite early on:
- 2) The construction of measuring equipment with the ability to measure what he thought he was seeing, and this required the development of a microscope *which could see beyond the scanning and scale range of the electron microscope, i.e., a “microscope” able to peer into the scale of sub-atomic reactions themselves, and thus able to “see” the quantum states of particles.*

This is breathtaking stuff indeed, and the extraordinary nature of Richter’s research, both in terms of the actual experimentation and rationalization he was doing, as well as in the construction of wholly

new types of measuring equipment he was attempting to design, are one reason so many more conventionally-minded scientists were all-too-willing to write Richter off as a fraud, for he was literally decades ahead of them not only in what he was attempting to *do*, but in how he was attempting to *measure* it.

By 1948, after the war's end, Richter had, at the behest of another displaced German scientist, aerodynamicist Kurt Tank of the Focke-Wulfe aircraft company,⁴⁸ contacted President Perón and persuaded him of the viability of an Argentine project in fusion. As Argentina had no supply of uranium of its own for a fission-based project, Perón was quick to see the importance of the idea, and backed Richter.

However, this is where the story takes yet another strange turn, one that, once again, gives lie to the public press reports and debunking of Richter that occurred in the American press after Perón's 1951 press conference. As the Air Intelligence Report in his Paperclip file records, Richter himself states:

I was not interested in the development of nuclear fission reactor systems but anxious to develop a controllable thermonuclear reactor system; there was a certain probability that the chain-reacting schemes, *developed in the fall of 1942*, ignited by a shock-wave-controlled arc plasma might turn out to become a controllable reactor system.⁴⁹

This is truly astounding information, for if true, then it means that Dr. Richter had succeeded in producing a sustained or almost sustained fusion reaction in a plasma, by means of shock waves, *in 1942*, without the need for multi-billion dollar Tokamak magnetic containment, high temperatures, or "gigantism" that forms so much of the cult and ritual of modern "public consumption" science! This is a step away from a "clean hydrogen bomb." As Stevens observes, "What he needed to do was fine-tune the procedure to achieve better control of it."⁵⁰

Richter and Perón signed a five year contract in October of 1948.⁵¹ This highlights yet another mystery, for is it likely that Perón would have signed a contract which obligated him to invest tens of millions of dollars on the word of an obscure German scientist,

without consulting his own scientists first?” Germanophile though Perón was, he was hardly foolhardy, and in my opinion, he would most likely have consulted *someone* about the viability of the project before investing so heavily in it, to the extent of buying equipment and constructing Richter’s facilities in remote Bariloche! This fact makes the *subsequent* behavior of Argentina’s scientists even more puzzling, if indeed they were the ones consulted! What had changed in the few short years to sour Perón?

The answer has already been suggested in the previous chapter, namely, Richter was under orders from somewhere else to shut the project down, and was following a carefully orchestrated script designed to make him and his project look fraudulent. As we proceed to examine Stevens’ incredible evidence, this possibility looms ever larger.

Indeed, as Stevens notes, the headquarters of Richter’s project was, once again, Huemul Island, which was “within an area habituated or perhaps even controlled by Germans of the Nazi era.”⁵² That’s putting it rather mildly, for as has already been seen, it was an area Bormann thought safe enough to reside in until Perón’s overthrow in 1955! Bear that date in mind, for it will become important in a moment.

For the moment, however, it is important to note that Richter claimed success for his 1951 experiments in Argentina, and the Air Intelligence Report of his Paperclip transcript reinforces this point:

On 16 February 1951 an exponential reactor system was ready for test. In the first test, the injection of lithium-6 enriched lithium into a shock-wave-controlled proton hydrogen plasma, for a short interval, produced a series of primary and secondary reactions, the helium-3 helium-3 reaction giving proof for the existence of self-reproducing reaction chains. In a second test, by jetting lithium-6-enriched lithium into avalanche (sic) of neutron-reproducing reaction chains were monitored. *In both tests, the self-reproducing-reaction chains were analyzed by means of excitation-energy discriminating ultra-violet sensitive proportional counter tubes.* At that time, a large-scale reactor system was under construction in which a self-sustaining chain

reaction should have been realized; however, this reactor system has never been completed, probably for reasons of sabotage.⁵³

Note the discrepancy between the Air Intelligence Report's indication that lithium-6 was used, and the Argentine investigation commission's statements that it was lithium-7.

While this may be a minor oversight, it is nevertheless significant that the Air Intelligence Report has Richter describing measuring equipment somewhat different, and perhaps more sophisticated than that described by the Argentine commission, was in use by Dr. Richter at Huemul. Was this the equipment that Dr. Richter apparently forgot to turn on, thus dooming his experiment to failure in the Argentines' eyes? Or, as is more likely, was it equipment that he altogether hid from the Argentine commission? Perhaps, perhaps not, but in any case *it is significant that the equipment Richter describes for the Americans is somewhat different than that observed by the Argentines.*

The Air Intelligence Report continues to describe Richter's 1951 tests. In a third test performed on October 26, 1951, "Richter injected boron into an avalanche of neutron-reproducing reaction chains, which had resulted from the injection of lithium into the shock wave, controlled, neutron producing deuterium plasma. The result was that the boron kept the reaction going."⁵⁴ But according to the Air Intelligence Report in the American government's Paperclip file, there's more going on with the behind-the-scenes physics than Richter's detractors, who were having a field day with him in 1951, were willing to admit:

Later on, *the plasma-collision-induced isomerization of indium-and rhodium nuclei has been proven by monitoring the radioactive emission of gamma quanta (sic); signal discrimination had to be provided against the shock-wave-induced brehmstrahlung background.*⁵⁵

For those who've been following my analysis of the Bell and its mysterious "fuel," the so-called "IRR Xerum 525," through my

previous books, *The SS Brotherhood of the Bell*, *Secrets of the Unified Field*, and *The Philosophers' Stone*, this will sound very familiar, for it was indeed metals in the platinum metals group, such as rhodium, that sparked American David Hudson's investigations of high spin state atomic nuclei.⁵⁶

In all of those books, I advanced the idea that the key to the physics of the Bell was *rotation and torsion shear – an effect similar to Richter's plasma shock waves* – were the key to its field effects, including reports of its levitation. Additionally, I speculated on the basis of the known data concerning its fuel, "IRR Xerum 525," that its probable recipe was an isotope of mercury – ideal in its own right for plasma experimentation – and some sort of *isomer*, such as thorium 229.^{57, 58} Isomers are *high spin state* nuclear materials that release their energy in the form of bursts of gamma rays when they de-excite or "slow down" from that state.⁵⁹

And there is one final connection to the Bell. As I have rationalized the device, I believe two types of electrical potential were involved, both high voltage AC and DC current, much like the references to Dr. Richter's plasma electrical arcs in the Air Intelligence Reports from his paperclip file.⁶⁰

The conclusion is unavoidable because the physics conceptions are all identical: *Dr Richter's Huemul "fusion" project was an extension and continuation of some aspects of the Bell project, Nazi Germany's most highly classified secret research project.* This conclusion will become more and more unavoidable as we proceed with our analysis. But in any case, it is now evident why Dr. Richter deliberately dissembled and created such strange behavior that the Argentines shut the project down, for its real masters could hardly have desired that any attention be drawn to it. After all, as the *Time* magazine and *Washington Post* articles cited in the previous chapter attest, America was watching.

Indeed, certain comments in Richter's National Archives file indicates that he was operating under pressure, not from Perón, but somewhere else, and it is worth considering these statements and their implications quite carefully, for they point, once again, to the continued existence of the Nazi International, and, moreover, to its probable control over Richter's project and its real, though highly

secret, purpose. Richter's lengthy typewritten statements are made in response to various questions on the official form he was provided by American authorities. The question that interests us is this:

c. Have you ever been arrested, sentenced, imprisoned, or court-martialed for any violation of law except for minor traffic violation?

Richter's response tells, briefly, *his* side of the whole "press conference" affair that blew the lid off of his project's secrecy:

It is true that I have accomplished series (sic) of exponential fusion experiments in 1951, *but against my strict advise (sic), Peron was announcing these results with a considerable display of exaggeration and propaganda.*

To protect U.S. secrecy in hydrogen bomb development in 1951, I refused to publish data (and to protect my scientific reputation) when the project was attacked by the press.

When Peron offered me the position of a National Director of Atomic Energy in 1951, I refused to accept this position to escape political interference with my work.

When Peron offered me a professorship at the Cuyo University of Mendoza, I was ignoring this offer not to become a 'political professor.'⁶¹

As indicated by Richter himself, he had attempted to *dissuade* President Perón from making any announcement about the results of the Huemul experiments. And his behavior in subsequently turning down Perón's blandishments is explicable in only two ways: the swindler was trying to avoid the exposure that such posts would inevitably bring, or Richter was trying to maintain the political independence of the project by not becoming more involved with Perón's government, perhaps under pressure from his hidden Nazi masters.

In support of the latter view, Richter elaborates further on his own interpretation of the Argentine commission, and then reveals a curious, and very significant, detail:

In July, 1951, I published an article in the United Nations World Magazine, New York, ('Argentina has no Atom Bomb'), mentioning for the first time the underlaying (sic) chain-reacting schemes of the exponential fusion experiments.

In the fall of 1951, the analysis of the exponential experiments revealed the existence of field-interaction-induced particle acceleration which led to a completely new concept of fusion reactor systems: a relatively large research program was set up to obtain more data.

(When Project Huemul was born in 1949, Peron demanded firmly in the presence of his ministers that I should not work out secret reports but keep all the data under strict secrecy; after having arrived at the new concept for fusion reactor systems, I was trying to improve secrecy.

When I was expelled from the reactor project in November, 1952, the authorities seized Huemul Island, got all the installations but not the vital analyzers – and no data).

A large-scale reactor system was under construction but has never been completed; sabotage was increasing at Huemul Island.

....

On September 2, 1952, a commission of deputies and a group of Argentine nuclear experts (?) arrived at Huemul Island; the only purpose of this commission (headed by the Minister for Technical Affairs, Dr. Raoul Mendé), was to paralyze the reactor project; facts did not matter at all and were mostly misunderstood; the 'findings' of this commission were pre-set in Buenos Aires, weeks before arrival at Huemul Island.⁶²



10. QUESTIONS:

c. Have you ever been arrested, sentenced, imprisoned, or court-martialed for any violation of law except for minor traffic violation?

Answer: Yes

Details: When having sent telegrams to the President of the Chamber of Deputies in September, 1954, protesting against unjust public sessions in congress, demanding public hearings, I had to serve a sentence of 1500 days detention in congress building, ordered by the Chamber of Deputies for violation of its privileges; there were no hearings, not in public and not in secrecy; my lawyer still says that I have not violated law by sending these telegrams.

d. Are there any unfavorable incidents in your life not mentioned herein which you believe may reflect upon your loyalty or reliability or upon your ability to perform the duties which you will be called upon to take?

Answer: Yes

Details: Since March, 1953, I was collecting the worst publicity possible. I would like to give some facts to correct the various distortions by the press:

When I went to Argentina in August, 1948, I came to this country to meet Prof. Turk, but Turk had already arranged for an audience with Peron and Peron personally became the sponsor of the reactor project. It is true that I have accomplished series of experimental fusion experiments in 1951, but against my strict advice, Peron was announcing these results with a considerable display of exaggeration and propaganda, to protect U.S. secrecy in hydrogen bomb development in 1951, I refused to publish data (and to protect my scientific reputation), when the project was attacked by the press,

when Peron offered me the position of a National Director of Atomic Energy in 1951, I refused to accept this position to escape political interference with my work,

when Peron offered me a professorship at the Cayo University of Mendoza, I was ignoring this offer not to become a 'political professor', when I was detained in congress for having violated the privileges of the deputies, the show was set up to prepare for oil negotiations,

the substitution of the Lonardi government by the Aramburu government explains to some extent the hostile attitude of the Lonardi government against the 'Richter case', (the Lonardi government detained me for 20 days in the headquarters of the Federal Police and for 20 days in the National Penitentiary for having been a favorite of Peron who was expelled from the reactor project in November, 1952),

2.2.0, 2.2.0.

APR 26 1999

Richter's Version of the 1951 Peron Press Conference



on October 25, 1951, in a third exponential test, it has been proven that the avalanche of neutron-reproducing reaction chains, resulting from the injection of lithium into a shock-wave-controlled, neutron-producing deuterium plasma, can be kept on a high level of reproduction factor by injecting boron.

In a press conference in December, 1951, I predicted in a camouflaged way what we call now thermonuclear fusion.

In July, 1951, I published an article in the United Nations World Magazine, New York, ('Argentina has no Atom bomb'), mentioning for the first time the underlying chain-reacting schemes of the exponential fusion experiments.

In the fall of 1951, the analysis of the exponential experiments revealed the existence of field-interaction-induced particle acceleration which led to a completely new concept of fusion reactor systems; a relatively large research program was set up to obtain more data.

(When Project Humul was born in 1948, Faron descended firmly in the presence of his administrators that I should not work out secret reports but keep all the data under strict secrecy) after having arrived at the new concept for fusion reactor systems, I was trying to improve secrecy.

When I was expelled from the reactor project in November, 1952, the authorities seized Humul Island, got all the installations but not the vital analyses - and no data.

A large-scale reactor system was under construction but has never been completed; sabotage was increasing at Humul Island.

In order to shift the reactor project from the political and propaganda level to a more reasonable and profitable commercial level, in December, 1951, I advised Faron to accelerate reactor development by linking the Argentine project with a highly industrialized country like the U.S.; much to my surprise, he showed himself interested in such a proposition and authorized me to arrange for preliminary industrial discussions.

A few months later, in March, 1952, the political situation in Argentina was obviously beginning to change.

On September 2, 1952, a commission of deputies and a group of Argentine nuclear experts (?) arrived at Humul Island; the only purpose of this commission (headed by the Minister for Technical Affairs, Dr. Raul Mendé, was to paralyze the reactor project; facts did not matter at all and were mostly misunderstood; the 'findings' of this commission were pre-set in Buenos Aires, weeks before arriving at Humul Island.

In November, 1952, I suddenly found myself expelled from the project and had to stop work on nuclear matters immediately, by 'presidential' order; I was forced to leave San Carlos de Bariloche for Monte Grande, near Buenos Aires.

There, although not being a prisoner, I was completely isolated during this period of exile - and it still has not been possible for me to get another job in Argentina because most of the Argentinians and foreign firms in Argentina were seemingly afraid of government reprisals.

DECLASSIFIED
Authority: E.O. 13526
APR 26 1999

Richter's Statement that Argentina Recovered No Data or Analyzers

Richter's opinion of the Argentine commission is clear enough. However, note the curiously significant statement that Argentina recovered absolutely no data or analysis equipment whatsoever from the Huemul project.

Recall that Dr. Balseiro in the previous chapter also encountered similar difficulties from Richter. One may discount the possibility that Richter retained his own copies in his own possession, for when he was forced to move to Buenos Aires and live under virtual house arrest, it would have been a simple matter for the Argentine

authorities to remove these copies, or – Argentina being Argentina – threaten him or his family if the data and analyzers were not turned over. Recall also that his potential *American* employers also asked for diagrams of equipment and summaries of recollected data from his Argentine and Nazi research projects, indicating that – at some level at least – the Americans did not have them either. There is only one other possible presence that could exert such pressure on Richter:

Argentina's Nazis.

Nor should the significance of Richter's persistent Gestapo problems escape our attention, for it will be recalled that Richter's first encounter with the Gestapo was when working on the atom bomb project with Baron Manfred Von Ardenne where, after being relieved of that position, he made his way to the A.E.G. and most probably in some connection to Nazi Germany's most classified research project, the Bell. Here he is again relieved of his post by the Gestapo *in the same year* – 1943 - as another Bell project engineer was relieved by the Gestapo after being denounced by future NASA flight director and Bell power plant designer, Dr. Kurt Debus! Even after this, Richter somehow manages to remain at A.E.G. to continue research.

If anything emerges from this it is that Richter would have been *well-known* to Gestapo chief Heinrich Müller, who was, after all, responsible for the security for SS *Obergruppenführer* Hans Kammler's secret weapons think tank. And if he was well-known to Müller, he was well-known to Bormann. Bormann's presence in the Bariloche area at the same time as Richter's can therefore hardly be coincidental.

3. Another Strange Parallel, Dr. Philo Farnsworth's Plasmator, and Another Strange Nazi Connection: IT&T

But attention certainly *was* drawn to it, at least in America, which, as we have seen, quietly and covertly was investigating and even interviewing Dr. Richter while its scientists and media were busily denouncing him publicly. To appreciate the significance of this covert American interest in Dr. Richter and his claims, it is worth recalling

briefly yet another scientist – this time an American one – who made similar claims about his ability to control fusion, and who made them, more over, in the early 1960s.

The scientist's name was Dr. Philo Farnsworth, and he was, by anyone's reckoning, a brilliant electrical engineer and scientist. It was Farnsworth who was the de facto inventor of commercially viable television in America, for he pioneered the development and personally patented much of the technology employed.⁶³ Farnsworth even appeared in the early CBS game show *What's My Line* in his capacity as "the inventor of television." If something could be done, or conceived of being done, with vacuum tubes, Farnsworth was the one who could pull it off.

Indeed, Farnsworth first conceived of the idea of using conventional and standard technology, employing modified vacuum tubes, for the process of controlling fusion while he was perfecting his television inventions. In this regard, two of his patents are vitally important, one concerns his so-called "Fusor" device and another his "Plasmator" device, both of which were no larger than a softball! Farnsworth's last technical patent, U.S. Patent number 3,386,883, "Method and Apparatus for Producing Nuclear-Fusion Reactions" was filed on May 13, 1966, and the patent was granted on June 4, 1968. First, it is worth a glance at a few of its technical illustrations. In doing so, the reader is reminded that the schematics describe a device no larger than a softball, into which a gas is injected. Surrounding the spherical device, small ion accelerators are placed which bombard the center of the gas, creating a plasma, which induces fusion by some novel means which will be explored in a moment. But first, a few of the schematics themselves:

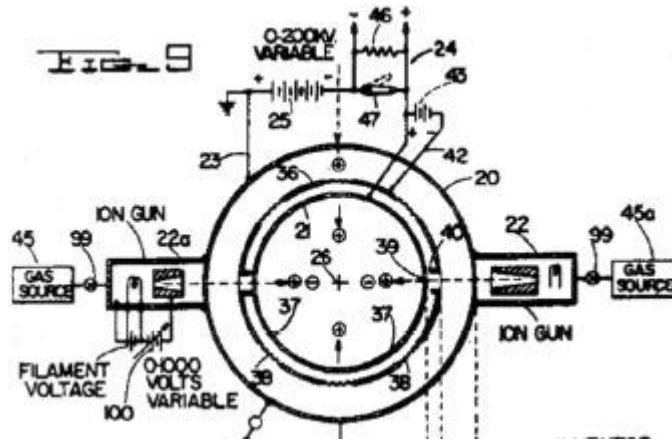

Farnsworth Schematic One, Figure 9, from U.S. Patent 3,386,883

One can see from this the ion guns surrounding the device.

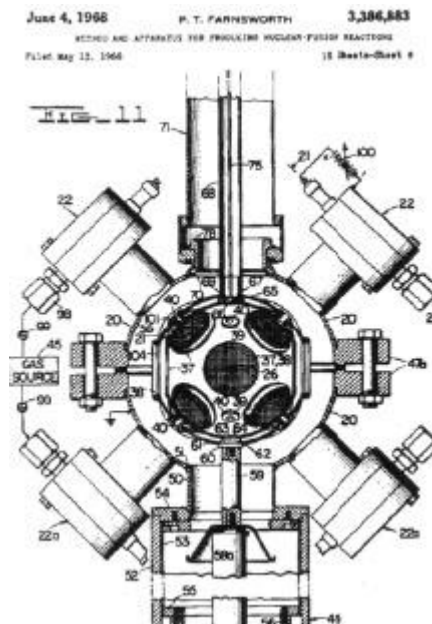

Farnsworth Schematic Two, Figure 11, from U.S. Patent 3,386,883

Showing the Actual Appearance of the Device

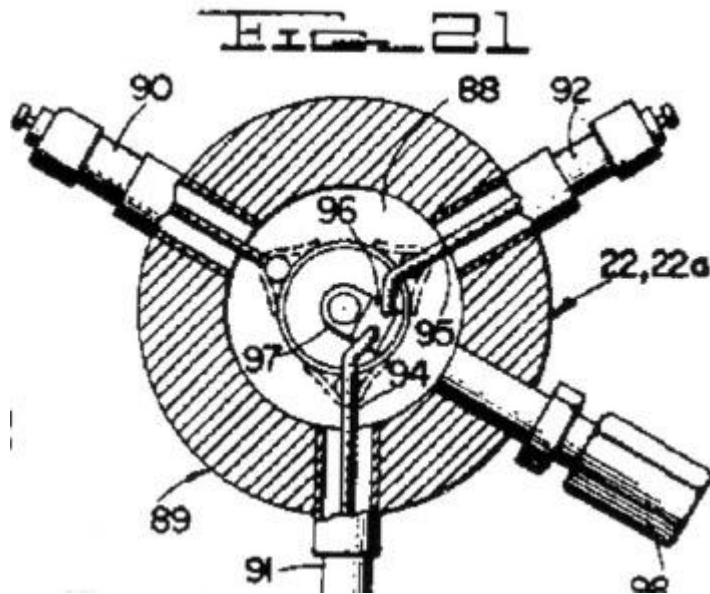

Farnsworth Schematic Three, Figure 21, U.S. Patent 3,386,883

With these pictures in mind, let us now cite the abstract of the patent itself, to discover what Farnsworth's rationalization for this device actually was:

A method and apparatus for producing controlled nuclear-fusion reaction by use of self-generated electric fields and inertial ionized-gas containment. The apparatus comprises a spherical anode which concentrically surrounds a cathode. A plurality of ion guns are mounted on the exterior of the anode in spherically spaced and diametrically aligned relationship such that the beam axes intersect at the center of the cathode. Appropriate apertures permit passage of positively charged particles outwardly from the cathode interior, but are biased negatively to prevent the flow of electrons into the interelectrode space.

A voltage is applied between the anode and cathode. Ions from the guns are propelled and focused into the center of the cathode establishing in the cathode interior a series of concentric spherical sheaths of alternating maxima and minima potentials called "virtual electrodes." The ions in the innermost

*“virtual electrode” have fusion energies, and are contained at a density sufficient to produce a self-sustained fusion reaction.*⁶⁴

This is breathtaking, for in some respects it parallels the conceptual thinking of Dr. Ronald Richter, though there is an added subtlety and nuance, and that is Farnsworth’s brilliant idea of containment of a plasma by means of *virtual electrodes*, i.e., by means of a field set up in and by the plasma itself.

Notably, Farnsworth was also thinking in terms of the same reactions as was Dr. Richter before him, most notably deuterium and helium-3.⁶⁵

With such a device Farnsworth actually claimed to have sustained a reaction for about half a minute ca. 1965. Following the usual media hoopla, however, Farnsworth’s breakthrough – which again was accomplished without billions of dollars, gigantic Tokamak magnets, and the customary rituals and bows to conventional science – disappeared after that. What happened?

The clue is afforded by what Farnsworth’s patent states at the very beginning of the document, which states that he is “assignor to International Telephone and Telegraph Corporation, a corporation of Delaware.”⁶⁶

While Farnsworth’s inertial confinement by dint of “virtual cathodes and anodes” within his Plasmator and Fusor devices are based on slightly different conceptions than Richter’s rotation-and-shock wave approach, it is likely that the *geometries* generated within the plasmas by Farnsworth’s device were similar if not identical, for ion bombardment of a plasma gas so confined would indeed generate shockwaves within the plasma which in turn would compress the gas to “fusion energies and densities” as the patent itself claimed. Small wonder, then, that I.T.&T. basically confiscated Farnsworth’s device, for as is now known, the connection between I.T.&T. and the Nazis – even to the extent of its involvement with the overthrow of Marxist Chilean President Salvadore Allende in conjunction with the Nazi colony at Cologna Dignidad and the American CIA – are well known, as was seen in part one of this book! Someone, somewhere, was trying to ensure that any public knowledge or scrutiny of the science involved in Dr. Richter’s or Dr. Farnsworth’s fusion devices never

occurred, for they led to a deeper and far more powerful physics than mere fusion. While Farnsworth's device, with its virtual cathodes and anodes, represents in some respects an advance on the thinking of Richter, Richter in some respects also has perceived what Farnsworth did not explicitly state: the need for *rotation and shockwaves*.

4. *Fusion, Torsion, and Stars: The Work of Dr. Nikolai Kozyrev*

The relationship of a *rotating* plasma to the control of fusion may seem obscure, unless one recalls the fact that a little known Russian physics genius by the name of Dr. Nikolai Kozyrev also discovered the same thing, a fact that made his research one of the most closely held secrets of the former Soviet Union. And like Richter, Dr. Kozyrev soon found his work publicly denounced by conventionally minded scientists in the state-sponsored newspaper *Pravda*. Kozyrev began his work, as I noted in my book *The Philosophers' Stone: The American "Gold," The Soviet "Mercury," and the Nazi "Serum"*, by observing that the conventional view of nuclear fusion in stars simply could not account for all the energy they were producing:

The whole principal motivation, by his own reckoning, for his decades' long investigation of torsion, and of the torsion amplifying and shielding properties of various elements and compounds, was precisely the fact that there simply not enough neutrinos being emitted by stars for the standard model of stars as gigantic perpetual fusion reactors – essentially perpetual hydrogen bombs – to be true.⁶⁷

As I observed a little further on,

The more than coincidental attack on Kozyrev in *Pravda* in 1959 effectively (prevented) him from open publication of his experimental results and theoretical conceptualizations, and the similarly-timed disappearance of discussion of clean fusion bombs in the open Soviet literature (is likewise suspicious). Let us speculate a bit.

We have already encountered the fact that the earliest atmospheric hydrogen bomb tests far exceeded their pre-test calculated yields. In other words, *just as (Kozyrev maintained was happening) in stars, some other energy source was being tapped into, and transduced by, the thermonuclear detonation itself.* And if we extend this line of speculation, the Russians most likely encountered the same phenomenon in their hydrogen bomb testing. Moreover, in Kozyrev, they had an astrophysicist who thought he knew *why stars*, also implicating thermonuclear processes, appeared *not* to be radiating enough neutrinos energy for the thermonuclear model to be true.

One may reasonably and logically conclude, therefore, that the 1959 *Pravda* attack on Kozyrev was really a cover story to denounce his work, to *de-legitimize* it to anyone in the West who may have been paying attention to it, while Kozyrev, and his work, disappeared – as they did – into the highest reaches of classification within the Soviet Union, for his work provided the necessary key to understand why H-bombs were returning such anomalous yields, yields that, moreover, most likely varied with the time of their detonation. Kozyrev knew why: it was because the bomb itself became, for that brief brilliant nano-second of the initial explosion, a dimensional gateway, a sluice-gate, opening the spillway to a hyper-dimensional cascade of torsion into the reaction itself.⁶⁸

And of course, when one says torsion, one is saying *rotation*; that is, the rotation of the plasma itself was the gateway transducing energy from “somewhere else” into the reaction.

Thus a logical question occurs. If a rotating shockwave in an electrically pulsed rotating plasma transduces this “extra energy from somewhere,” then did Dr. Richter notice a similar thing, long before Kozyrev and the Russians did?

Buckle your seatbelts, because *this* is where the story gets *extremely* interesting!

5. Richter, Ram Jets, Shockwaves, and Aurora

In one of the Air Intelligence Reports reproduced (in their entirety) by researcher and author Henry Stevens, Richter expounds at length for his prospective American employers – in 1956! – on a propulsion system based on combining “rocket and ramjet operations within the same propulsion system.”⁶⁹ He elaborates on this idea a little further into the report:

A rocket is just another branch of jet propulsion and becomes a ram jet system when the mass (and the oxygen, in case of chemical combustion processes) to be discharged is taken from the outside atmosphere instead of being stored in the aircraft fuselage itself.

A jet propulsion system has to be developed which is operating as a rocket system at take-off and becomes self-operative as an intermittent and steady flow ram jet system gradually with increasing speed of flight. The continuously controlled conversion of one propulsion phase into the other can be achieved by the control of the combustion process itself.⁷⁰

So far, so good. But what has this to do with his fusion-plasma shockwave research? Everything, for a little further on in the same report, he makes clear that he is thinking in terms of a wholly new type of ramjet:

In the first line, the advantages of a shock-wave-controlled ram jet system lies in the fact that all the different systems of propulsion are combined in one, making also possible the continuously controlled conversion of one propulsion system into the other, in flight.⁷¹

In other words, Richter was proposing an aircraft that would use rockets for take-off and to attain the necessary velocity for the ramjet phase to become operable, since ramjets only begin to be able to operate at speeds in excess of approximately 200 miles per hour. Once obtaining this speed, the aircraft could convert to ramjet operation, and gradually climb to extraordinary altitudes on the very

edge of space, where, again, the rocket phase could take over. Richter was proposing, in other words, a combination aircraft and spaceship capable of extraordinary speeds and altitude. If all this is beginning to sound uncomfortably familiar, hang on, there's more.

That Richter was not thinking in terms of an ordinary ramjet is made abundantly clear by his remarks that occur almost in the exact center of the Report:

For many years, the author was experimenting with a new shock wave generating process, the shock waves being generated by an electro-magnetically controlled extremely hot arc plasma zone. By the same process technique, shock waves can also be generated in combustion chambers and in gaseous zones heated by the impact of nuclear energy.

The analysis of the injection of gaseous jets into a superposition of powerful shock waves revealed interesting data in regard to the penetrability of shock-wave-controlled zones. In the course of these investigations, *it became obvious, for instance, that the valves of an intermittent ram jet system can be substituted by shock waves, thus providing for the continuously controlled conversion of an intermittent into a steady flow ram jet system.... On that basis, it should become possible to start an intermittent shock-wave-controlled ram jet system without the help of acceleration-assisting means by a series of shock-wave-generating explosions.*⁷²

Note that Richter has proposed the following possibilities as implications of his plasma shockwave discoveries:

- 1) A nuclear-powered ramjet, which would make any aircraft employing the technology to possess virtually unlimited operational range and duration, a range and duration presumably only limited by the limitations of any human crews operating it;
- 2) This ramjet system would not be conventional in the sense of employing a simple valve, such as was the case of the shutter-valve on the German V-1 "buzz bombs", for example,

since the shock waves themselves would constitute the valves opening and closing the admission of combustible fuel into the system;

- 3) Finally, Richter has made clear that his new type of ramjet would function as a series of closed, controlled explosions: it would, in short, be a kind of *ramjet pulse engine*. In fact, as Richter makes abundantly clear, this type of engine might not even need the conventional rocket phase in order to “get up to speed” for the ramjet to operate, but might be able to do it from the initial takeoff phase of flight.

If all this sounds familiar, it ought to, for just such a system – sans the nuclear aspect – is alleged for the super-secret American spy-plane, the so-called Aurora. Indeed, one researcher even captured photographs of a peculiar contrail, allegedly from the Aurora, in the skies over Texas. The contrail was a conventional contrail in every respect except for the fact that every so often, at regular intervals, there appeared to be a ball or puff of smoke, like beads spread out on a necklace string, or like doughnuts. But Aurora is late 1980s technology (if it exists); Richter, however, was proposing the idea *in 1956* on the basis of experiments and discoveries made in Nazi Germany a decade and a half earlier than that!

The conceptual connections between Richter’s plasma experiments and his ramjet proposals are made clear in the next Air Intelligence Information Report from his Paperclip files, IR 80-56, again dated 1956. The Report begins by a significant disclaimer:

Approving Officer is not technically qualified to comment on the subject presented. However, Dr. Richter is, *in the opinion of qualified German scientists resident in Argentina(!), a complete fraud* who has “parlayed” a limited scientific background and a glib tongue to obtain much publicity: i.e., *the explosion of the so-called “Argentine Atomic Bomb” in 1952*. In the opinion of these qualified German scientists, the disgrace and obscurity that Dr. Richter now enjoys is better than he deserves.⁷³

Note three implications of this disclaimer.

First, long after the Argentine press conference and Richter's denunciation by the Argentine Investigative Commission as a fraud (and the ensuing media campaign that only served to reinforce that view), the clear implication of the Air Intelligence Information Report is that the Americans, for some reason, decided to quietly investigate Dr. Richter *anyway*, and this can only imply that there was some scientific merit to his ideas, notwithstanding the public campaign against him.

Secondly, note the fact that the American report makes clear that "*German scientists resident in Argentina*" were the ones consulted first, and that they regarded Richter as a fraud, apparently doing so with some vociferousness, since the report maintains that these scientists thought Richter well deserved his new obscurity. In short, the implication is that the "German scientists resident in Argentina" – a polite euphemism for Nazi scientists – were the ultimate origin of the press campaign and denunciation of Richter's project, a view which tends to support our analysis in the previous chapter that Richter's strange behavior before the Argentine investigative commission appears to have been deliberately contrived *precisely in order to de-legitimize both the project and Richter's scientific rationalizations of it, in much the same fashion as Pravda would de-legitimize the work of Dr. Nikolai Kozyrev before it went "deeply black" within the Soviet Union.*

Finally, note that the Report clearly and unambiguously reaffirms what the original press frenzy and the Argentine commission itself drew attention to, namely, that Richter had set off some sort of *explosion* on Huemul, which nevertheless was not heard a mere 6 ½ miles away in the nearby town. In other words, the Report reaffirms, in its own roundabout way, that Richter's work had weaponization potential.

And the date is significant, for this is four to five years *after* Richter had been almost universally denounced as a fraud, an occurrence brought about, as noted in the previous chapter, by his strangely anomalous behavior! In brief, someone – namely the "German scientists in residence in Argentina" – had gone to a great deal of trouble to make it appear that Richter and the whole fusion project at Huemul was completely bogus while they quietly and quickly

relocated the project with new personnel; and someone – namely the Americans – weren't buying that story in 1956!

In any case, Richter's own words in this second Report are worth citing. He states that "the operation of a plasma reactor system can be considerably improved by jetting a mixture of reactants through the high energetic arc plasma zone at very high velocities."⁷⁴ This is the basis of the connection between his nuclear pulse-ramjet proposals and his plasma research. In the remainder of the report, Richter goes on to outline his 1936 discoveries that formed the basis of his conceptualization and subsequent experiments in Argentina, reinforcing once again the fact that in spite of public disgrace, the American military was paying a great deal of secret attention.

But the real bombshell is dropped at the end of Air Intelligence Information Report IR-145-56, where a very different, and presumably the final, American evaluation of the German scientist is given.

The material contained in this report is beyond the technical ability of the Preparing Officer to evaluate. Conversation with dr. (sic) Cooper and Dr. Multhopp, scientists of the Glenn L. Martin Company of the United States who have interviewed Dr. Richter, revealed that there may be something of value in the work and theory of Dr. Richter.

The report was submitted by Vergil Nestor, Lt. Colonel, USAF.

A little later on, on July 3, 1956, the same Lt. Col. Nestor submitted two memoranda to the Headquarters of the United States Air Force to the attention of the Air Attache Branch in Washington, D.C. As one memorandum reveals, American interest in Richter was hardly based on their evaluation of him as being a fraud:

CONFIDENTIAL

The Foreign Service of the United States of America
Office of the Air Attache
United States Embassy
Buenos Aires, Argentina,

175-R&D 3 July 1956
(Ucl)

SUBJECT: Dr. Ronald Richter (See IR-76-56, 79-56, 80-56
and 145-56)

TO: The Director of Intelligence
Headquarters, USAF
ATTN: Air Attache Branch
Washington 25, D.C.

1. A recent visit by a group of U.S. atomic energy scientists to Argentina, headed by Dr. John Hall, resulted in a conversation among Dr. Richter, Dr. Hall and two other scientists in the group. The undersigned officer attended a meeting with Dr. Hall subsequent to this conference and the following items of interest relative to Dr. Richter are being forwarded for information and whatever action is required:

a. Dr. Richter is considered by Dr. Hall to be “a mad genius”. Along the same lines Dr. Hall stated that Dr. Richter is thinking in the year 1970. Dr. Hall was quite impressed with the knowledge, theories and work of Dr. Richter.⁷⁵

In other words, the American military, far from considering Dr. Richter a fraud, was slowly waking up to the idea that they were dealing with “a mad genius” thinking *decades* ahead of the rest of the pack! The memo is signed by Lt. Col. Vergil N. Nestor, USAF, air attaché to the American embassy in Argentina’s capital.

But there’s more. A second memorandum of the same date, presumably in reply to Lt. Col. Nestor, according to Stevens, “contains a significant paragraph.”

3. Dr. Richter’s work in Argentina should be reviewed by a competent specialist. The recommendation of Dr. Hall to interrogate Dr. Richter is concurred in. Specifically, this headquarters desires the following information:

- a. Technical data, diagrams and plans concerning his experiments in Argentina and Germany in 1943 (reference IR-76-56) with discussion of his problems and results.
- b. Resume of his research activity, problems and results while at Berlin-Suhler-Waffen-und-Fahrzeugwerke during 1937/38 (reference IR-76-56).⁷⁶

In other words, after having interviewed Dr. Richter in 1956 concerning his “fraudulent” work in Argentina, the American military not only considered him “a mad genius” who was “thinking in 1970,” but also wanted to know more about work done during and prior to the war in Nazi Germany!

But why pay attention to wartime work done in the Nazi Reich at all?

The answer is nothing less than stunning, and horrifying, for “Dr. Richter’s mind had already moved beyond the production of a sustained fusion reaction and the technological implication, thereof.”⁷⁷ A Stevens notes, “a clue to this broader thinking is given in his specialties” as noted in his Paperclip file, for these include the “development and testing of highly-turbulent, magnetic-field-controlled fission and fusion plasma systems. Experimental approach to solar flare conditions and to the explosion-tendency of the solar plasma, ultraviolet excess analysis, *excitation of space structure by pulsation-controlled plasma implosion, testing the limitations of quantum mechanics and quantum dynamics, Experimental approach to the unified field theory and to the velocity of propagation of gravity, a.s.o.*”⁷⁸

In other words, Richter had seen something in his plasma experiments in Germany that led him to a similar conclusion as Dr. Nikolai Kozyrev later observed in Russia: the plasma fusion processes were transducing excess energy from the geometrical distortions they were introducing in space-time itself. As Stevens quips, “It is clear that Dr. Richter’s method was experimentation, not merely conducting ‘research’ by scribbling mathematical babble on a chalkboard and then insisting on a Spinosian set of definitions of exactly what the physical universe actually is.”⁷⁹

As if all this were not enough, Dr. Richter spells it all out very plainly, by stating that his work is really about an “experimental approach to zero point energy...deriving from the analysis of exponential fusion experiments in 1951....”⁸⁰ This was made evident to Richter when

Analyzing the induction spectrum of an extremely turbulent shock-wave-superimposed plasma of ordinary proton hydrogen, a specific class of signals revealed the existence of sort of ‘decaying structures’, not resulting from eventual electron capture by protons, forming decaying neutrons, another class of signals, characterized by extremely large amplitudes and very small pulse width was even indicating the existence of a certain exchange mechanism of energy, the source of the energy still being a mystery....

Richter spells it out clearly:

(We) assume, that highly compressed electron gas becomes a detector for energy exchange with what we call zero point energy, zero point energy derives from the exclusion principle, the exclusion principle derives from empirical data, in a shock-wave-superimposed, turbulence-feed-back controlled plasma zone exists a high probability for cell-like super-pressure conditions, gas represents an enormously high energy capacity of exchange processes, about 10^{10} (kilowatt hours) per unit volume, on the basis of exchange coupling, it seems to be possible to ‘extract’ a compression-proportional amount of zero-point energy by means of a magnetic-field-controlled exchange fluctuation between the compressed electron gas and sort of cell structure in space..., representing what we call zero point energy, it seems even possible that the large-amplitude fluctuation signals derive from a mechanism of energy-conversion unknown to us....plasma implosion analysis might turn out to become an approach to a completely new source of energy.⁸¹

This is heady wine indeed, for clearly, Dr. Richter has, on the basis of his *experiments*, projected conceptions that will only occur decades later, namely, the idea that space-time has a *lattice-like or cellular structure, which, when distorted, becomes the source of physical forces, energy, and action, and that the means to do this lies through shock waves in a turbulent plasma, i.e., via rotation.*

In short, at almost every turn, Dr. Richter's thought, and the Huemul project itself, evidences itself as a continuation of the Bell Project, up to and including the latter's probable weaponization potential as a kind of "torsion bomb" based on rotating and electrically pulsed plasma and shockwaves.

6. Ball Lightning, The A.E.G. and Richter

As if all of this were not enough to convince the most hardened scientific skeptic that there was more to Richter's Huemul project than meets the eye, or than the public denunciations of his work as fraud would allow, there is even a brief mention of him in a recent scientific paper on ball lightning, analyzing it as a high frequency spherical cavity resonator, and surprisingly, it concerns the published memories of Richter's Argentine associate, the scientist Ehrenberg, whose similarly anomalous behavior and statements to the Argentine investigation commission about the heavy water production facility on Huemul also contributed to their recommendations to Perón to shut the project down. The paper states:

When W. Ehrenberg came back from Argentina to Germany (in the middle of the) fifties he reported about the first large scale attack on nuclear fusion of Dr. Ronald Richter on the island of Huemul near St. Carlos de Bariloche/ Argentina. Inside a "pole cross" of his discharge device Richter had produced high temperature, horrible 'plasma balls', he reported. Although Ehrenberg had essentially misunderstood the concept of the discharge circle not becoming aware of the high voltages and huge capacitors employed, it is remarkable, that Richter had

spoken to him about values and conditions of resonance –not going into more details.⁸²

But what is the connection of ball lightning to all this?

7. The Bell Flies to Argentina: Brooks, Ball Lightning, A.E.G., and the Bell

As I noted in my previous book on the Bell, *The SS Brotherhood of the Bell*, British researcher Geoffrey Brooks maintains, on the basis of his Argentine sources – Brooks lives in Buenos Aires – that the Bell and its project documentation flew to Argentina from Norway aboard a Junkers 390.⁸³ The significance of Bormann’s assignation of *Luftwaffe Kampfgeschwader 200* to SS General Kammler’s direct control is now evident, for with control of those long-range heavy lift aircraft, and with so much documentary and photographic evidence pointing to or corroborating a heavy Nazi presence in Bariloche that most likely included Bormann himself, the total context thus also argues quite strongly that the Bell and Kammler made its way there as well, and that Richter’s project represented the continuation of some aspects of the Bell project.

While researching and writing this book, Mr. Brooks contacted me, and shared with me by email the following information, which, with his gracious permission, has been included here:

Dear Dr. Farrell:

...

During the 1930s, AEG had a laboratory on the roof of the Charité Hospital in Berlin. Its purpose was to study ball-lightning, which is of course the basis of the Bell theory.

Best wishes,

Geoffrey Brooks⁸⁴

The A.E.G. Corporation, or *Allgemeine Elektrizitäts Gesellschaft*, was, of course, the same firm that built the powerplant for the Bell, a powerplant in turn designed by future NASA space flight

administrator at the Kennedy Space Center in Cape Canaveral, Florida, Dr. Kurt Debus.⁸⁵ And one of the early project codenames for the Bell project according to Igor Witkowski was precisely the *Charite-Anlage* project, the codename under which Witkowski learned about the Bell's extreme classification at the very pinnacle of the Third Reich's secret weapons projects.⁸⁶

8. A Possible Corporate Connection to Argentina's Huemul Project: A.E.G., and Back to the Bell

Yet another small clue as to the nature of the Huemul project and its possible relation to the wartime Bell project is afforded by Paul Manning. As Allied pressure mounted for Argentina to break relations with the Axis powers and join the Allied cause, a former German ambassador to the country began to hold meetings on his farm in Argentina's Córdoba province, anticipating an eventual break between the two countries. The purpose of the meeting was to form an organization that could continue to represent German interests, and particularly business interests, after the German, Italian, and Japanese diplomatic corps in the country were sent home in the eventuality of a break in relations between Argentina and the Axis. The group that was formed included both Argentine and German corporate and military representatives, and would, of course, be fully integrated into Bormann's postwar organization.

Significantly, one of these corporations was the A.E.G.,⁸⁷ or *Allgemeine Elektrizitäts Gesellschaft*. This was the very corporation Dr. Richter was working for at the end of the war, according to Stevens.⁸⁸

In other words, we have not only the same physics conceptions involved in the Bell Project and Dr. Richter's Huemul project, and the same personnel somehow involved, i.e., Richter himself, but there is an identifiable link to one of the German corporations involved: the A.E.G. itself.

D. The Conclusions Imply a Possible Scenario

All of this permits a speculative scenario to be outlined, given the conclusion that we have reached that Richter's Huemul project involved a continuation of the Bell project, either in its entirety or in certain particular respects. The scenario begins with the madcap dash of General Patton's Third Army in 1945, across southern Germany, into Austria, and, more importantly, into Pilsen, Czechoslovakia, the nerve center and headquarters of SS General Kammler's secret weapons think tank. As already outlined in this book, this is because American intelligence had learned how close the Germans were to marrying their a-bombs to a workable delivery system, or because they possibly knew also of some project within the *Kammlerstab* involving "doomsday physics" far more fearful in its potential than mere atom or even hydrogen bombs. There is also the possibility that U.S. General Patton's Third Army was steered there by German psychological operations via the "National Redoubt" myth.

As I noted in *The SS Brotherhood of the Bell*, Polish researcher and author Igor Witkowski maintains that the Americans were trying to *reassemble* the Bell's scientific team as best as they could. In this respect, the covert American interest shown in Dr. Richter's work is possibly further testament to the fact that this interest continued very quietly long after the war. All these considerations imply that the Bell, its project documentation, and General Kammler did *not* make their way to America. It remained in German, that is to say, Nazi hands after the war, and its science continued to be developed by them, initially, as has been seen, in Argentina, and after the project was "closed down" by Perón, it most likely was moved elsewhere.⁸⁹

When Richter shared some of his experimental results with dictator Perón, however, the project security was very nearly blown, for Perón's response – his infamous press conference of 1951 – was hardly anticipated by Richter or his hidden Nazi masters, one of whom, as we have averred in this chapter, was most likely Martin Bormann himself. With world attention focused on Argentina, on Dr. Richter and on the Huemul project, the decision was taken to discredit Richter and the whole enterprise publicly, and Richter and his team were given their orders, orders that scripted their carefully anomalous behavior that guaranteed the project's demise.

Perón, however, was not easily put off the scent, for in addition to assembling a native Argentine scientific commission, he quietly solicited the help of Bilderberger and former SS officer, Prince Bernhard of the Netherlands. Bernhard, whose pro-Nazi background, membership, and sympathies were thus evident, himself sent a scientist – Dutch physicist Bakker – who most likely reinforced the Argentine commission's findings, and the project was shut down. Bernhard, a major shareholder in Royal Dutch Shell, would thus have had two motivations operating to keep the project out of the prying public eye: the first being because such a technology and its promise for energy would have made petroleum based energies and economies as obsolete as the dodo bird, and the second because, as a former SS officer, he was beholden to the still-extant chain of command that culminated with SS generals Kammler, Müller, and most importantly, Bormann himself. They would have wanted the project kept quiet for obviously different reasons.

Given the care, however, that the Nazis took to ensure that the original Bell project did not fall into any Allied hands after the war, one may be reasonably certain that a similar fate awaited the Huemul extension of that project: Richter, now a public figure, was retired like Gerlach (the Bell project's actual head in Nazi Germany) before him, as being too high profile. Another scientist was likely chosen to head it up, and the project was most likely moved – we know not where – and continued.

But was the Huemul project in fact a continuation of the Bell project?

There is one final piece of evidence that has not yet been presented. As already noted, Sharkhunters founder Harry Cooper, who contacted this author as this book was being written, led an expedition to Rio Negro province of Argentina, and photographed the many examples of German architecture in the region, not the least of which was the suspiciously large plastic surgery clinic cum hotel in the middle of nowhere.

But this is not all that Cooper photographed. Knowing of Richter's Huemul project, Cooper visited the island home of Richter's laboratories, and photographed the numerous ruined bunkers and

facilities on the island. One photograph in particular literally took my breath away when I saw it.

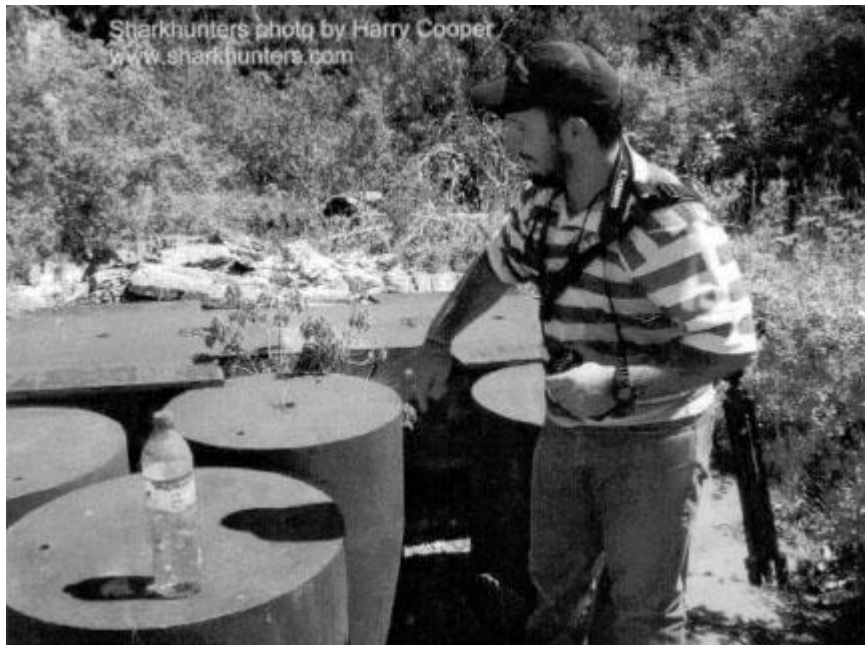

*Metal Drums, Remains of Richter's Huemul Fusion Project,
Photograph Courtesy of Harry Cooper and Sharkhunters,
www.sharkhunters.com*

As readers of any book dealing with the Bell, whether Igor Witkowski's *Truth About the Wunderwaffe*, Nick Cook's *Hunt for Zero Point*, or my own books *SS Brotherhood of the Bell*, *Secrets of the Unified Field*, or *The Philosophers' Stone* by now knows all too well, the actual Bell device employed, in its interior, two *counter-rotating metal drums* which were used to spin its "fuel," the IRR Xerum 525. No one knows exactly what these drums that Cooper photographed were used for, only that they had something to do with Richter's project.

But we know, or at least, are permitted to speculate on the basis of all that has been herein presented, that these drums are yet another clue that Dr. Richter and his project were continuing the work begun long before by Professor and Nobel physics laureate Dr. Walther Gerlach, a man whose specialty was magnetic spin resonance, and gravity, in a project that merited a classification higher than Nazi

Germany's atom bomb itself, a classification of *Kriegsentscheidend* or "war decisive."

When *that* original Bell project, along with Richter's own theoretical rationalizations, which similarly invoked hyper-dimensional physics, the unified field theory, zero point energy, high-spin high-turbulence plasma shock waves, electrical arc pulsing, and rotating plasma itself are all taken into consideration along with Bormann's suspicious presence in the very same region, and along with Richter's peculiar behavior to the Argentine investigation commission, then the conclusion seems all but certain:

The postwar Nazi International was continuing the development of the very technologies that gave them control of the energies of the very fabric and structure of space-time itself, energies and technologies that would alter the very structure of world finance, geopolitics, technologies that held such horrendous weaponization potential that it would make an H-bomb look like a firecracker, and they weren't *about* to let anyone else have it.

If it seems by now that we have strayed far from the science fiction novels of Wilhelm Landig, there is one application of the Bell technology that, as Richter also implied, involves space itself. To it, and the postwar Nazi determination to dominate space, we now turn.

¹ Henry Stevens, Stevens, *Hitler's Suppressed and Still-Secret Weapons, Science, and Technology*, pp. 290-291. Many of these documents are included in the appendix of this book.

² No author, "Double Check," *Time Magazine* (June 4, 1952), www.time.com/time/magazine/article/0,9171,858087,00.html?iid=chix-sphere, p. 1, emphasis added.

³ Jim Marrs, *The Rise of the Fourth Reich: The Secret Societies that Threaten to Take over America* (William Morrow, 2008), p. 48.

⁴ Carter Hydrick's, *Critical Mass* contains much valuable information. See also my *Reich of the Black Sun: Nazi Secret Weapons and the Cold War Allied Legend* (Adventures Unlimited Press), pp. 35-43, and my *The Philosophers' Stone: The American "Gold," The Soviet "Mercury," and the Nazi "Serum,"* (Feral House, 2009), chapter 10.

⁵ Dr. Eugene Mallove, cited in Henry Stevens, *Hitler's Suppressed and Still-Secret Weapons, Science, and Technology* (Adventures Unlimited Press, 2007), pp. 258-259.

⁶ *Ibid.*, p. 258.

⁷ Stevens, *Hitler's Suppressed and Still-Secret Weapons, Science, and Technology*, p. 259, emphasis added.

⁸ *Ibid.*, p. 260.

⁹ ATIC: Air Technical Intelligence Command.

¹⁰ Stevens, *Hitler's Suppressed and Still-Secret Weapons, Science, and Technology*, pp. 260-261, citing the National Archives and Records Administration, Foreign Scientist Case Files 1948-1958, Box 54 of Record Group 330, File on Dr. Ronald Richter, emphasis added.

¹¹ This sounds suspiciously like another, much more well-known, but no less controversial microscope: that of physician Royal Raymond Rife. On Lt. Col. Tom Bearden's analysis, Rife's microscope, with its "tuning procedure", was probably seeing the resonance effects of the *quantum states* of the viruses he was claiming to observe, rather than seeing viruses optically, as Rife himself claimed, much to his eventual chagrin.

¹² *Ibid.*, p. 261.

¹³ www.gizadeathstar.com.

¹⁴ Joseph P Farrell, "Does This Ring the Bell?" (February 19, 2008), www.gizadeathstar.com.

¹⁵ Stevens, *Hitler's Suppressed and Still-Secret Weapons, Science, and Technology*, p. 261.

¹⁶ *Ibid.*

¹⁷ *Ibid.*, pp. 261-262.

¹⁸ *Ibid.*, p. 262.

¹⁹ Emphasis added.

²⁰ See my *Reich of the Black Sun*, pp. 25-52 for a summary of Von Ardenne's crucial role in the Nazi, and subsequent Soviet, a-bomb projects, and for a summary of Hydrick's case concerning the Auschwitz I.G. Farben "Buna" plant actually being a huge uranium separation facility. Von Ardenne's process was the Nazi equivalent to

Lawrence's beta calutrons in the United States, though it was *more efficient* than Lawrence's. Several of these cyclotrons in use at the Auschwitz plant would certainly account for the facility's anomalously high electrical consumption (if it were really a Buna plant its high electrical consumption makes no sense). But as I also revealed in my most recent book *The Philosophers' Stone: The American "Gold," The Soviet "Mercury," and the Nazi "Serum"* (Feral House, 2009), there are other even *more* advanced isotope enrichment technologies that may have been in play at Auschwitz.

²¹ Igor Witkowski, *The Truth About the Wunderwaffe* (European History Press, 2003), pp. 256-259.

²² Stevens, Stevens, *Hitler's Suppressed and Still-Secret Weapons, Science, and Technology*, p. 262.

²³ Photo courtesy of Igor Witkowski, *Czwrate Rzesza*.

²⁴ Harry Cooper, "Argentina's Place in the War," KTB #209 *Sharkhunters: the Official Publication of the U-Bootwaffe*, p. 10.

²⁵ *Ibid.*, p. 11, emphasis in the original. *Sharkhunters* simply calls the town somewhere near Bariloche by the German name of *Stadt*, the German word for "city," in order to protect the families that still live there.

²⁶ Harry Cooper, "Argentina's Place in the War," KTB #209, *Sharkhunters: the Official Publication of the U-Bootwaffe*, p. 11.

This fact does raise interesting questions, given the heavy Nazi and German presence in the province, the more so because, as will be seen later, Bariloche was home base to none other than Martin Bormann. Was Eisenhower being "vetted" for his suitability as a presidential candidate by this group, in a "Bohemian Grove" or Bilderburger Group style meeting? Or was Eisenhower being told "the way things really are"? We will never know, of course, but if the alleged visit be true, it does put his subsequent and most famous speech, the one given to the country when he was leaving office and warning about the dangers of the "military-industrial complex," into a unique perspective. Indeed, as I averred in my book *Reich of the Black Sun*, Eisenhower may not have been talking solely about the *American* military-industrial complex at all.

²⁷ Harry Cooper, "Plastic Surgery Clinic... in 1945," KTB #209, *Sharkhunters: the Official Publication of the U-Bootwaffe*, p. 14.

²⁸ Paul Manning, *Martin Bormann: Nazi in Exile* (Lyle Stuart, Inc. 1981), p. 204.

²⁹ Manning, *Martin Bormann: Nazi in Exile*, pp. 204-205, emphasis added.

³⁰ Manning, *Martin Bormann: Nazi in Exile*, pp. 205-206, emphasis added.

³¹ *Ibid.*, p. 211.

³² SA, i.e., Special Agent.

³³ Needless to say, the editors of the series of essays in the book in which this document appears do not accept the scenario of Bormann's survival, based on other correspondence between British MI-5 and MI-6 and the FBI; the British denied having *any* knowledge of Bormann's whereabouts. Of course, they might have been lying.

³⁴ The document is found in Richard Breitman, Norman J.W. Goda, Timothy Naftali, Robert Wolfe, eds., *U.S. Intelligence and the Nazis* (Cambridge University Press, 2005), p. 424. I D.M. Ladd to Hoover, 15 May 1948, NA, RG 65, 65-55639-(1-24), box 38.

³⁵ Needless to say, the editors of the series of essays in the book in which this document appears do not accept the scenario of Bormann's survival, based on other correspondence between British MI-5 and MI-6 and the FBI; the British denied having *any* knowledge of Bormann's whereabouts. Of course, they might have been lying.

³⁶ *Ibid.*, p. 206.

³⁷ *Ibid.*, p. 207.

³⁸ Manning, *Martin Bormann: Nazi in Exile*, p. 208, emphasis added.

³⁹ *Ibid.*, emphasis added.

⁴⁰ *Ibid.*, p. 211.

⁴¹ In this respect, see what I wrote concerning "Red Mercury" and the Bell's "Serum 545" in *The SS Brotherhood of the Bell*, pp. 272-308, *Secrets of the Unified Field*, pp. 275-282, both published by Adventures Unlimited Press, and my *The Philosophers' Stone: The*

American "Gold," The Soviet "Mercury," and the Nazi "Serum" (Feral House, 2009), chapters 10-12.

⁴² "Huemul Project," *Wikipedia*, en.wikipedia.org/wiki/Huemul_Project, p. 1, citing Rainer Karlsch, *Hitlers Bombe* (DVA, Germany, 2005). Emphasis added.

⁴³ Ibid.

⁴⁴ Dr. José A Balseiro, "Report About the Experiments of Dr. R. Richter, according to what was Witnessed by Me During the Visit made to the Atomic Energy plant at Isla Huemul, from 5 to 8 September 1952," www.ib.edu.ar/ informes-huemul/reports-huemul-principal.html, p. 4, emphasis added.

⁴⁵ Dr. José A Balseiro, "Report About the Experiments of Dr. R. Richter, according to what was Witnessed by Me During the Visit made to the Atomic Energy plant at Isla Huemul, from 5 to 8 September 1952," www.ib.edu.ar/ informes-huemul/reports-huemul-principal.html, p.5, emphasis added.

⁴⁶ Henry Stevens, *Hitler's Suppressed and Still-Secret Weapons, Science, and Technology* (Adventures Unlimited Press, 2007), p. 260.

⁴⁷ Cited in Henry Stevens, *Hitlers' Suppressed and Still-Secret Weapons, Science, and Technology*, pp. 260-261, emphasis added.

⁴⁸ Tank had designed Germany's most successful and deadly piston engine fighter, the Ta-152, a modification of the Focke-Wulfe 190 which first entered service in 1941. While a rare aircraft, the Ta-152 did see combat and was the equal if not better of the American P-51 Mustang, an extraordinarily reliable, sturdy, and deadly fighter in its own right. But Tank also designed, during the war, a turbojet fighter aircraft that bears an all-too-peculiar resemblance to the Soviet MIG-15. Under Tank's direction, Argentina produced its own independent prototype version of a similar fighter jet aircraft in the early 1950s.

⁴⁹ Cited in Henry Stevens, *Hitler's Suppressed and Still-Secret Weapons, Science, and Technology*, p. 263, emphasis added.

⁵⁰ Stevens, *Hitler's Suppressed and Still-Secret Weapons, Science, and Technology*, p. 263. This revelation also puts into a different interpretive light the allegations, recorded in my *Reich of the*

Black Sun, that the Nazis successfully detonated an enormous “fuel air” bomb in 1944, whose destructive blast wave was recorded for 12 kilometers from the center of the detonation. If indeed this was really some sort of “clean hydrogen bomb” it could very well have been described as a “fuel air bomb” or “liquid air” bomb without doing an injustice to the actual physics principles involved. The explosion of such a device might also account for the strange exchange between Albert Speer and American prosecutor at the beginning of the Nuremberg Tribunals that I also record in that book (see *Reich of the Black Sun*, pp. 190-192, and pp. 66-67 for each subject respectively.

⁵¹ Ibid.

⁵² Stevens, *Hitler’s Suppressed and Still-Secret Weapons, Science, and Technology*, p. 263.

⁵³ Cited in Stevens, pp. 263-264, emphasis added.

⁵⁴ Stevens, *Hitler’s Suppressed and Still-Secret Weapons, Science, and Technology*, p. 264.

⁵⁵ Cited in Stevens, p. 264, emphasis added.

⁵⁶ See my *The Philosophers’ Stone: The American “Gold,” The Soviet “Mercury,” and the Nazi “Serum”* (Feral House, 2009), part two.

⁵⁷ For the discussion of the Bell and my rationalization of its internal configuration, see my *The SS Brotherhood of the Bell: NASA’s Nazis, JFK, and MAJIC-12* (Adventures Unlimited Press, 2006), pp. 141-310, and my *Secrets of the Unified Field: The Philadelphia Experiment, The Nazi Bell, and the Discarded Theory* (Adventures Unlimited Press, 2008), pp. 227-288. For my discussion of the role of isomers in high-spin state physics, and for some sort of isomer, possibly thorium-229, in the recipe of Serum 525, and for the relevance of high-spin physics to the processes of fusion, see my *The Philosophers’ Stone: The American “Gold,” The Soviet “Mercury,” and the Nazi “Serum”* (Feral House, 2009), pp. 89-109 (for high spin state super-deformed nuclei, gamma bursts, and isomers), pp. 146-195 (for high spin torsion physics and fusion processes), and pp. 273-337 (for isomers, torsion, Serum 525, and thorium-229).

⁵⁸ *The Philosophers' Stone: The American "Gold," The Soviet "Mercury," and the Nazi "Serum"* (Feral House, 2009), part four.

⁵⁹ For the gamma bursts, see my *The Philosophers' Stone: The American "Gold," The Soviet "Mercury," and the Nazi "Serum"* (Feral House, 2009), pp. 94-95, and *The SS Brotherhood of the Bell*, pp. 242-250.

⁶⁰ For my argument that the Bell used two types of electrical potentials, see my *Secrets of the Unified Field: The Philadelphia Experiment, the Nazi Bell, and the Discarded Theory*, pp. 270-277, 280-282.

⁶¹ Emphasis added.

⁶² Emphasis added.

⁶³ Many mistakenly believe Farnsworth *invented* television, which is clearly not the case, since the Nazis broadcast the 1936 Olympics throughout Berlin on television. And a case could be made that the Russians came *up* with the idea and the first primitive sets in the late 1920s. But Dr. Farnsworth clearly impacted its development significantly, by patenting a whole range of tubes, cameras, and equipment that made it commercially viable and reliable. Farnsworth did begin conceiving of television in the 1920s, independently of his European counterparts, and began to map out the necessary technologies to make it work.

⁶⁴ Philo T. Farnsworth, "Method and Apparatus for Producing Nuclear-Fusion Reactions," U.S. Patent 3,386,883, from the abstract, emphasis added.

⁶⁵ *Ibid.*, p. 1, line 60.

⁶⁶ *Ibid.*

⁶⁷ Joseph P. Farrell, *The Philosophers' Stone: The American "Gold," The Soviet "Mercury," and the Nazi "Serum"* (Feral House, 2009), p. 193, referencing A.P. Levitch, "A Substantial Interpretation of N.A. Kozyrev's Conception of Time," p. 1.

⁶⁸ Joseph P. Farrell, *The Philosophers' Stone*, pp. 194-194, emphasis in the original.

⁶⁹ Air Intelligence Information Report IR-79-56, cited in Henry Stevens, *Hitler's Suppressed and Still-Secret Weapons, Science, and Technology*, p. 268.

⁷⁰ Ibid., p. 270.

⁷¹ Ibid., p. 271.

⁷² Air Intelligence Information Report IR-79-56, cited in Henry Stevens, *Hitler's Suppressed and Still-Secret Weapons, Science, and Technology*, p. 270, emphasis added.

⁷³ Air Intelligence Information Report IR-80-56, cited in Stevens, *Hitler's Suppressed and Still-Secret Weapons, Science, and Technology*, p. 273, emphasis added. The approving officer in this case was George R. Herrman, Colonel, USAF.

⁷⁴ Air Intelligence Information Report IR-80-56, cited in Stevens, *Hitler's Suppressed and Still-Secret Weapons, Science, and Technology*, p. 273.

⁷⁵

⁷⁶ Cited in Henry Stevens, *Hitler's Suppressed and Still-Secret Weapons, Science, and Technology*, p. 299.

⁷⁷ Ibid., p. 289.

⁷⁸ Stevens, *Hitler's Suppressed and Still-Secret Weapons, Science, and Technology*, pp. 289-290, emphasis added.

⁷⁹ Ibid., p. 290.

⁸⁰ Ibid., p. 291.

⁸¹ Henry Stevens, *Hitler's Suppressed and Still-Secret Weapons, Science, and Technology*, pp.; 291-292.

⁸² Dr. Paul-J. Hahn, "Ball-Lightning: A HF Cavity Resonator?", www.p-j-hahn.de/kugelblitz2.html, p. 3.

⁸³ See Geoffrey Brooks, *Hitler's Terror Weapons: From V-1 to Vimana*, p. 3, cited in my *SS Brotherhood of the Bell*, p. 171.

⁸⁴ Geoffrey Brooks, personal email to the author, 1 July, 2008, 2:24 PM.

⁸⁵ See my *SS Brotherhood of the Bell*, p. 154-156.

⁸⁶ Igor Witkowski, *The Truth About the Wunderwaffe* (European History Press, 2003), pp. 256-259.

⁸⁷ Paul Manning, *Martin Bormann: Nazi in Exile*, p. 221.

⁸⁸ Henry Stevens, *Hitler's Suppressed and Still-Secret Weapons, Science, and Technology*, p. 262.

⁸⁹ There are two places, in my opinion, that the project may have then gone, one would be northwestern Canada or British Columbia, where there have been persistent reports of German enclaves and bases, or to America, where the Nazis might have struck a deal with certain elements of NASA during this crucial time frame... as Richard Hoagland says, "Stay tuned!..."

Part Four: The Control of Space

“After all it is known for sure that (Dr. Hermann) Oberth was not connected with the centre in Peenemünde, since in this case he would have undoubtedly held at least one of the positions of command, in other words the fact of his engagement would have been known (thousands of specialists employed there worked after the war in other countries, from the USA and USSR to even Egypt and so is out of the question that a possible secret of this kind could not be kept hidden). So it seems that some kind of alternative program existed, being carried out for a long time, and quite a serious one at that.”

Igor Witkowski,
The Truth About the Wunderwaffe,
p. 259.

✠ 11 ✠

“Masons, Magicians, and Nazis:” Richard C. Hoagland and Mike Bara on NASA’s Secret History

“Based on our analysis as presented in (Dark Mission: the Secret History of NASA), it is also our opinion that NASA ‘s entire lunar expedition program - culminating with the incredibly successful manned Apollo Project - was carefully conceived, from the beginning, as a kind of ‘alien reconnaissance ‘ followed by an ‘alien artifacts retrieval program. “

Richard C. Hoagland and Mike Bara¹

The sudden though very covert interest shown in the work of Dr. Ronald Richter by the U.S. Air Force in 1956 came at a particularly tense period in the early Cold War of the mid-1950s. In 1956, the Space Race was already up and running, though few people actually knew about it. Behind the scenes, however, there was frenetic activity as both superpowers raced to be the first into space, and ultimately, to the moon. A year later, on October 4, 1957, the Russians won the first significant leg of the race by orbiting mankind’s first artificial satellite, Sputnik. This behind-the-scenes space race activity provides the necessary context from which to the U.S. Air Force’s sudden interest in Dr. Richter, for certainly his conceptions concerning the zero point energy would have been of

great interest to America's space program. Moreover, if the Air Force quietly suspected that his project at Huemul represented a continuation of aspects of the Bell project, with its obvious potential for propulsion and "anti-gravity," not to mention its weaponization potential, then this too explains the American interest.

That interest also implies that not all was straightforward and transparent as was alleged for America's early space program, and no authors have insisted more upon that point than New York Times bestselling authors Richard C. Hoagland and Mike Bara, with their book *Dark Mission: The Secret History of NASA*. However, why talk about NASA *at all* in a book dealing with the postwar survival and influence of a "Nazi International"? That there were "former" Nazis in NASA in some very prominent positions everyone knows, but to maintain that they actually influenced NASA in a "pro-Nazi direction" seems to stretch the bounds of plausibility. But that influence is precisely what Hoagland's and Bara's *Dark Mission* is in part about, and when their research is viewed against the larger context of postwar Nazi activities outlined here, the implications are stunning, and chilling, indeed.

A. Ancient Names and Ritual Alignments

Any attempt to summarize Richard Hoagland's work on NASA's ongoing cover-up of space anomalies in one short chapter would, of course, be doomed to failure. After all, that work has been ongoing for over a quarter of a century, and has engaged several scholars and experts from a variety of disciplines and specialties. And, of course, any attempt to summarize his and coauthor Mike Bara's *Dark Mission* would be similarly doomed, for a similar reason: the book is over five hundred pages long. But their book is directly relevant to the question of the existence – or non-existence – of Martin Bormann's Nazi International, for as we shall now see, they argue persuasively that the Nazis not only exhibited a great degree of influence inside of NASA during the heyday of its formation up to the Apollo Moon landings, but indeed, that the Nazis exercised the *greatest* influence inside the organization, eventually co-opting – or

making common cause with – two other significant, hidden, and esoteric influences in the space agency.

With this said, however, a caveat is also required:

Hoagland's and Bara's book is a *complex* book, a tapestry of very discreet types of evidence and argument, and a subtle pattern of historical analysis and various themes. By concentrating on only *three* of those themes - namely, Hoagland's "ritual alignments" model, the suppression of the hidden purposes and motivation for NASA and the role of Kennedy in trying to change some aspects of those hidden purposes, and finally, the role of three esoteric groups jockeying for ultimate power in the agency – we are perforce distorting that tapestry and the densely-knotted fabric of Hoagland's and Bara's arguments and analyses. No summary of this nature can substitute, therefore, for an actual reading of the book.

By the same token, however, when their remarks concerning these themes are placed into the wider historical context of Bormann's strategic evacuation plans, the demonstrable role of postwar Nazis penetrating and exploiting areas of geopolitical conflict, their equally demonstrable role in the postwar economic recovery of West Germany, the highly dubious behavior of West Germany and Neo-Nazi groups prior to, during, and after the forced annexation of East Germany during the reunification, the demonstrable role of Nazis in supporting and fomenting Muslim radicalism and terrorism, not to mention the self-evident Nazi influence in Dr. Richter's postwar "fusion" project in Argentina, and the actual physics it *really* represents, then their remarks not only take on a new and ominous significance, but also serve to corroborate the existence of that International and to highlight some of its goals and agendas.

1. NASA and NACA: "Never A Straight Answer" from "Not A Civilian Agency"

One of the facts in *Dark Mission* that literally leaps off the page is that NASA is not, and was never intended to be, at its innermost core and highest levels, a civilian agency:

The governmental institution known as NASA is a department of the Executive Branch, ultimately answerable solely to the President of the United States, an Agency created through the National Aeronautics and Space Act of 1958. NASA ostensibly is “a *civilian* agency exercising control over aeronautical and space activities sponsored by the United State.”

But contrary to common public and media perception that NASA is an open, strictly civilian scientific institution, is the legal fact that the Space Agency was quietly founded as a direct adjunct to the Department of Defense, tasked with specifically assisting the national security of the United States in the midst of a deepening Cold War with its major geopolitical adversary, the Soviet Union. It says so right in the original NASA Charter:

“Sec. 305...(i) The (National Aeronautics and Space) Administration shall be considered *a defense agency of the United States* for the purpose of Chapter 17, Title 35 of the United States Code...”(Emphasis added.)

In another section of the act, this seldom-discussed *defense* responsibility – the ultimate undercutting of NASA’s continuing public façade as a strictly civilian, scientific agency – is blatantly spelled out:

“Sec. 205...(d) No (NASA) information which *has been classified for reasons of national security* shall be included in *any report* made under this section (of the Act)...”(Emphasis added.)

Clearly, from this and the other security provisions incorporated in the Act, what the Congress, the press and the American taxpayers get to see of NASA’s ultimate activities - including untouched images and data regarding what’s *really* on the Moon, on Mars or anywhere else across the solar system – is totally dependent on whether the President of the United States (and/or his legal surrogates in the Department of Defense and the “intelligence community”) has already secretly classified that data.²

This ability of NASA to cloak or classify data returned from its manned and unmanned probes is the heart of the controversy that has raged between Hoagland, Carlotto, and other researchers of space anomalies such as the “Mars Face” and other strange features in Cydonia, on the one hand, and NASA on the other.

2. *Masons, Magicians, and Nazis*

This cloaking-by-classification, however, is further compounded by the introduction of three parties of powers within NASA that would have their own reasons and agendas for doing so. Over the course of years of research, Hoagland and Bara identified three groups, each with their own connections deep within the world of occult and esoteric traditions, that each held significant positions of managerial power and influence within NASA: Masons, Magicians, and Nazis. The Nazi aspect of NASA was, of course, self-evident and even well-known in popular culture, and even called forth some biting satirical criticism and humor in some segments of American society.³ But less well known were the other two occult and esoteric-based groups, the Masons and Magicians. As Hoagland and Bara put it:

Let us be clear:

We are uniformly, unabashedly “conspiracy theorists,” and have – against our wills – become truly convinced that there has been a conscious, carefully planned and permanent cover-up by NASA of some of its most extraordinary discoveries made in the course of the Agency’s forty-year history.⁴

All this, of course, implies that there was a secret agenda to the early space race, one having nothing whatsoever to do with beating the Soviet Union to the Moon:

Based on our analysis as presented in (*Dark Mission: the Secret History of NASA*), it is also our opinion that NASA’s entire lunar expedition program – culminating with the incredibly successful manned Apollo Project – was carefully conceived, from the beginning, as a kind of ‘alien reconnaissance’ followed by an ‘alien artifacts retrieval program.’⁵

But who would have conceived, at that early date, such a covert agenda for the Moon landings?

Their answer is, again, direct, and laden with implications:

The enthusiastic architects of the continuing NASA ... cover-up, in part, are the same heroes we have been encouraged to worship as some of the leading pioneers of our technological era. Their names are synonymous with America's achievements in space science and rocket engineering. In many cases, they are also men with secret pasts – Germans, Egyptians, Englishmen and Americans, men at the very fringes of rational thought and conventional wisdom. These literal “fringe elements,” then, are divided into three major groups inside the Agency, as best as we can tell at present. For the purposes of this volume, we shall call them the “Magicians,” the “Masons,” and the “Nazis” – and deal with each group separately.

Each “sect” is led by prominent individuals, and supported by lesser known players. Each has stamped their own agenda on our space program, in indelible but traceable ways. And each, remarkably, is dominated by a secret or “occult” doctrine, that is far more closely aligned with “ancient religion and mysticism” than it is with the rational science and cool empiricism these men promote to the general public as NASA's overriding mantra.⁶

For Hoagland and Bara, these three groups may be more or less headquartered or concentrated in the following areas of NASA:

- 1) The Magicians, represented by rocket engineer and solid-fuel expert Jack Parsons, with his own direct and personal involvement with notorious British magician Aleister Crowley, the *Ordo Templi Orientis* and his Golden Dawn magicians. Parsons was well-known to have connections to other practicing occultists, such as L. Ron Hubbard, the founder of “Scientology,” and to have practiced himself on numerous occasions black magic and sex magic rituals. The influence of

Parsons and “the Magicians” runs directly from Parsons to the Jet Propulsion Laboratory and other NASA centers clustered around it or directly tied to it;

- 2) The Masons, represented by famous NASA director during the formative Mercury-Gemini-Apollo years, James Webb, and by various astronauts like Buzz Aldrin, the second man on the Moon, who were all Masons. The Masonic influence was, according to Hoagland and Bara, felt throughout NASA not only in Webb’s largely successful attempts to “democratize” NASA and raise public interest and awareness of space science in public schools throughout the country, but also in the esoteric influence it wielded in the selection of mission names, mission patches and logos, and throughout the astronaut corps, about which more in a moment. The Masonic influence is thus centered upon the central NASA bureaucracy in Washington, D.C. and, at that time, within the astronaut corps itself. In typical Masonic fashion, it was a *dispersed* influence rather like the system of Masonic lodges;
- 3) The Nazis, represented by prominent German scientists such as Von Braun, Arthur Rudolf, Kurt Debus, and space medicine specialists such as Hubertus Strughold, and so on. This influence was centered around Von Braun and his team, first in the immediate postwar years in New Mexico, later in Alabama and other installations with prominent Nazi presence.

Hoagland’s and Bara’s documentation of the esoteric influence being exerted quietly and behind the scenes by these three groups is itself worth considering.

3. Mission Patches, Ancient Names, and Ritual Alignments

a. Mission Patches

Three of the most compelling sets of evidence they adduce for the quiet exercise of this hidden occult influence are in the forms of mission names and patch logos, and the pervasive use of names

derived from classical Egyptian or Greek mythology on the one hand, and the “ritual alignments” model on the other.

For instance, if one looks at the official patch for the Apollo Program (below), armed with out preceding “heads-up” regarding the bizarre NASA focus on all things “Egyptian,” it becomes elemental to match the “A” (for “Apollo”) as an actual stand-in for “Asar” – the Egyptian designation for “Osiris.” This successful decoding of the hidden Egyptian meaning of the Apollo patch is redundantly confirmed – because “Asar/Orisir” is none other than the familiar Greek constellation of “Orion” – which is, of course, the background stellar constellation in the patch itself.

In case you think such ritual symbolism is some kind of temporary historical aberration, confined only to the Apollo Program and the 1960s, think again; when NASA recently selected a patch design for its new “CEV” spacecraft, which will eventually replace the Shuttle – and ultimately take American astronauts back to the Moon, look what NASA curiously picked again (below).⁷

Hoagland and Bara then reproduce NASA’s own patch designs:

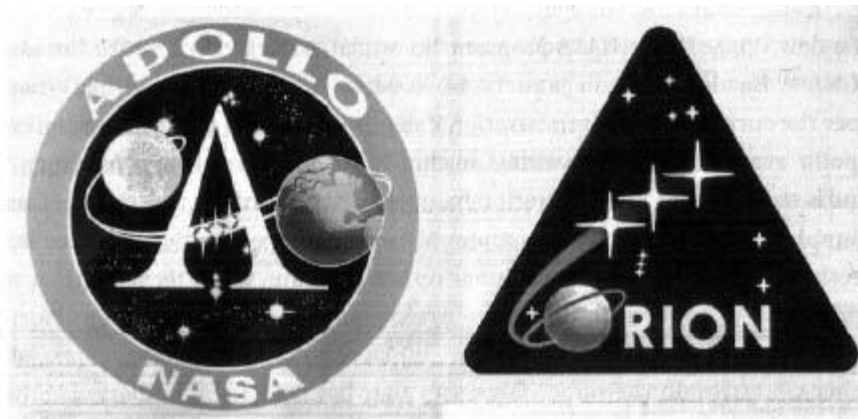

*Apollo and Orion Mission Patches Depicting the Constellation Orion in the Apollo Patch, and the Three Stars of Orion’s Belt in the Orion Patch*⁸

They then comment on the Apollo patch as follows:

In looking at the patch, it struck Hoagland just how incongruent it was with the stated goals and mythology of NASA's official Apollo Program to the Moon.

The patch depicts the Earth and Moon, with a flight path tracing from Cape Canaveral to a landing spot on the Moon. The lunar disk is overlaid with a mythological deity – presumably Apollo – and there is a large “A” in the center of the patch. The design was built around a very curious feature – the constellation of Orion, with its three distinctive belt stars comprising the bar in “A”.⁹

The history of the official adoption of the names for NASA's step-by-step manned space program - Mercury, Gemini, and Apollo – that would culminate with manned landings on the Moon only served to highlight the strangeness of the Apollo Program “logo,” for the project names were deliberately adopted by Abe Silverstein from Graeco-Roman mythology at a conference in July of 1960.¹⁰

Hoagland looked closer, and the names “Mercury” and “Gemini” quickly revealed their *own* strangeness:

As far as the mythology goes, Mercury, the gods' messenger, seems appropriate for the single man capsule and its quick missions. Yet the NASA symbol for Project Mercury is a representation of the *element* mercury, rather than the Greek god Mercury, and is similar to a stylized Egyptian ankh.... Alchemists considered mercury the “first matter” from which all other metals were derived. So was this a dual, *alchemical* meaning for the name “Project Mercury?”

Gemini, which means “the twins” in Latin, could not only refer to the two-man capsule, but also to the rendezvous and docking procedures which were perfected on Project Gemini and which were crucial to the later Apollo missions to the Moon. Gemini is also frequently referenced to the constellation that borders Orion and boasts the twin stars Castor and Pollux as its most

prominent features; other myths link Castor and Pollux with the morning and evening stars (the planet Venus).

Certainly, there is an inherent “duality” with all of these associations that well fits the “twins” designation of the NASA Program. Two astronauts... two vehicles rendezvousing in space... the twin stars Castor and Pollux.¹¹

But it was the Apollo patch that remained anomalously strange.

b. Ancient Names

Why call NASA’s earliest manned space flight programs Apollo – or for that matter, Mercury and Gemini – at all? Why the classical mythological and astrological focus? And why call it *Apollo* at all when the very constellation depicted in the patch is *Orion*? Hoagland consulted a “semi-official book” on the Moon program, which included a short citation from *World Book Encyclopedia* describing the mythological associations of Orion. Orion, the “mighty hunter,” was the son of the Graeco-Roman god of the sea Poseidon-Neptune. The goddess Artemis-Diana fell in love with Orion, but her brother, Apollo, took exception to this and tricked Artemis-Diana into killing Orion.¹²

And at this point in the “semi-official” history of the Moon program, the obvious question occurred:

Even this description, full of line after line about “Orion” compared to a single mention of Apollo shows how much more important Orion is to the patch than Apollo. So why call the Program “Apollo” at all? And why name the program after a petulant “god” who tricks his sister into murdering her lover? Is this the image NASA wanted of its first space pioneers, rather than the mighty hunter Orion? Why not just call the Project “Orion”? No matter how you look at it, the Greco-Roman designation of Apollo just doesn’t fit such a noble and risky venture as Man’s first foray to another world.¹³

The deliberate mixing of an Egyptian reference in the Apollo Program “logo,” however, is significant, for Orion is, of course, another reference to Osiris, who plays such a central role in the Egyptian death-and-resurrection myth, and in that myth, there was a direct connection to the Moon.

For those who do not know the basic outlines of this legend, Osiris was murdered (again through a trick) at the hands of his brother, Set, symbolized by the constellation Taurus. Vengeance is taken upon Set-Taurus by the Osiris’ son, Horus, represented by the constellation Leo, while Osiris’ wife Isis, represented by the star Sirius and in some cases “associated with the Moon,”¹⁴ resurrects Osiris.

The story, Hoagland and Bara comment, is laden with “paleophysical” meanings, for it is

Full of astronomical references, including hints (via key “coded” numbers in the narratives) that the Egyptians fully understood the concepts of precession, lunar cycles and stellar motion. *There are also strong hints that these beings were not mythical “gods” at all, but rather real flesh and blood beings from an advanced civilization that visited Earth in antediluvian times.*¹⁵

As anyone who has read my own book *The Cosmic War: Interplanetary Warfare, Modern Physics, and Ancient Texts*, such an interpretation is not at all out of synch with ancient texts, for that *is in fact what those texts themselves state*. Both Egypt and Sumer viewed themselves as a legacy – and a declined one at that – from something far more ancient and much more sophisticated. As those texts indicate, the “gods” indeed taught early mankind the arts, and *some* of their advanced sciences, of civilization. And as I also demonstrated in part three of my previous book *The Philosophers’ Stone: The American “Gold,” The Soviet “Mercury,” and the Nazi “Serum,”* such interpretations of these texts was common currency in the esoteric circles and secret societies hovering in the background of the Nazi Party.

But that left the initial question even more starkly outlined:

What is a mythological *Egyptian* stellar deity doing representing an official *U.S. governmental* exploration of the Moon? And in a program known under the designation of a Greek 'sun god,' Apollo. Why not, for example, "Diana" – the Greek goddess of the Moon?

The initial answer is quite simple: "Apollo" is actually "Horus" – if one examines in detail Greek mythological literature and its derivations from the earlier Egyptian. Horus, like Apollo, is the Egyptian "god of the sun" (and also, curiously, ruled over Mars).¹⁶ Thus, it turns out that the \$20 billion NASA Apollo Exploration Program of the Moon was, in fact, nothing less than a disguised "Osiris/Horus Lunar Landing Program"... straight out of ancient *Egypt*.¹⁷

But why associate the Egyptian god of rebirth and resurrection, Osiris, via his son Horus-Apollo, to this program at all?

It was only after Hoagland noted the name of another space vehicle – the shuttle Atlantis – that he began to put the pieces together. What if this *wasn't* the first time Man had reached across space to touch the Moon? What if the ancient Egyptian "Zep-Tepi" (literally, "the first time") Era of Osiris/Isis/Horus was not a myth... but a *reality*?¹⁸

In other words, the very choice of the Apollo Program "logo" and its very name, "Apollo" itself, symbolized the covert mission of the program, namely, to reconnoiter and recover technology from that lost "first time."

With this key in hand, Hoagland began to search the record for other Egyptian connections in the names associated with the Apollo program.

And, he found them.

The Lunar Module of Apollo 15 was named "Falcon," and "Falcon of the Horizon" was, of course, one of the titles of Horus.¹⁹ Additionally, "the Apollo 16 (Lunar Excursion Module) had been

openly named ‘Orion.’”²⁰ The Apollo command module Columbia “drew its name from St. Columba – a sixth-century monk who, in Masonic lore, brought a ‘scared stone’...to Scotland from Egypt.”²¹

c. Ritual Alignments

But program “logos” and Egyptian connections were not all that Hoagland discovered. Perhaps the *most* significant indicator – if not surely one of the most controversial – was his discovery that NASA’s Moon landings appeared to have been deliberately coordinated with *astrological* significances in mind. The key mission that tipped him off, as far as the Moon program was concerned, was Apollo Ten. Here is it necessary to cite *Dark Mission* at length:

With all of the primary technical and mission planning components having been tested and proven out, the next mission was a full-up dress rehearsal for Apollo 11. Launched May 18, 1969, Apollo 10 acted as a pathfinder for Apollo 11’s “Eagle,” following the same descent path that Apollo 11 would two months later. Eventually, Thomas P. Stafford piloted Snoopy to within 8.4 miles of the lunar surface (about 44,000 feet), prompting Lunar Module Pilot Gene Cernan to comment ominously; “Man, we’s getting down among them.”

Given that their altitude was nearly 50,000 feet above the lunar surface we can’t help but wonder what Cernan was talking about. At that altitude, lunar surface features, even mountains, would be obscure and far away. However, given where Stafford and Cernan were at that moment, passing through Sinus Medii and heading on toward Mare Smythii, the only thing they could have been “down among” – at 50,000 feet – would be Hoagland’s theorized miles high glass domes. Undeniably, the location and the altitude would be correct for that to be what Cernan was talking about.

This bizarre comment also raises the other strangely incongruous aspect of Apollo 10; while the spacecraft was theoretically fully capable of landing on the Moon, inexplicably, it was *not* given the capability to do so.

Not only was the Mission denied the fuel to make a safe lunar landing (the tanks on-board were literally only half-filled, but the (Lunar Module) “Snoopy” was a crippled version of the “real” vehicle, unable to physically land on the lunar surface.

Politically, this makes no sense.

Still in a fierce race with the Soviet Union to be the *first* to land a man on the Moon, Apollo 10 had everything necessary to accomplish this long sought after political goal – *except*, the tools to do so. The Saturn V, the (Lunar Module) and the (Command Service Module) had all been tested on previous missions, and the NASA long-distance (lunar) communications network was tested on Apollo 8. There was no practical, canonical reason *not* to land Apollo 10. With only two more shots at making the goal Kennedy’s “end of the decade,” the question is, why *wait*?

As he delved ever deeper into the arcane, *Egyptian* mysteries surrounding these supposedly secular, “scientific and engineering” NASA missions, Hoagland finally found his answer:

Because it wasn’t “time” yet.²²

In other words, the only way to explain why Apollo 10 had not been given the mission assignment to make a lunar landing was quite simply that it did not fulfill some hidden requirement of the esoteric Egyptian agendas apparently driving or influencing NASA planning at a very deep level.

Testing this hypothesis, Hoagland began to enter data into computer programs designed to show astronomical alignments. The result stunned him, for at the exact moment that Buzz Aldrin celebrated his now famous “communion ceremony” on the Moon, Sirius, stellar symbol of Isis, resurrector and consort of Osiris, was at 19.5 degrees elevation from the horizon. And 19.5 was one of the key numbers “encoding” a hyper-dimensional tetrahedral physics.²³ Furthermore, this implied that well before the Apollo 11 Moon landing in 1969²⁴ there were individuals within NASA who were fully informed about aspects of this hyper-dimensional physics.²⁵ To give the esoteric and numerological connections even more weight, Hoagland also noted that Aldrin’s communion ceremony took place

exactly 33 minutes after “the Eagle had landed.”²⁶ And Aldrin was one of the astronauts who was a Mason. The odds against all this being coincidental are, of course, quite high. Further investigation yielded similar Egyptian astronomical correlations for Apollo 12.²⁷

These alignments implied something else, and something extraordinarily significant. Consider only the complex degree of planning and coordination that has to occur in order for such a mission to be *pre-planned*:

Going to the Moon(or any other planet) with current propulsion technology (such as Apollo’s Saturn V), requires a tremendous amount of careful and prior mission planning. Because fuel and rocket thrust are very limited, leaving for a specific planetary designation with a precisely-timed pre-planned arrival time and specific landing site in mind, requires an immense amount of detailed knowledge of key “celestial mechanics.” This encompasses all relative planetary and spacecraft motions, ranging from precise planetary orbits, to planned spacecraft departure and arrival times, to the individual planetary rotation rates themselves. The latter critically impact mission departure and arrival times, if not the intended landing site geometry itself.²⁸

Bluntly put, these considerations meant nothing less than that the astronomical-astrological alignments exhibited by these landings “*must* have had the *highest* mission planning priority, over all *other* publicly stated goals of the Apollo landing program. They would have to be given top priority over all other objectives, be they political, general mission science, specific lunar geological sampling and even crew safety.”²⁹

Even the man who trained the astronauts and who ultimately selected them had his own Egyptian connections; in fact, he, Farouk El-Baz, was Egyptian! Moreover, his father was an expert in Egyptian religion and particularly its astronomical symbolisms.³⁰ There were even ritual alignments operative when President Kennedy made his famous speech before Congress, setting the goal

of reaching the Moon before the decade was out, for as it turned out, those alignments, coupled with Apollo 12's and Surveyor 3's landing site, fixed an "entire 'lunar ritual network.'"³¹

And this was the vital clue that would eventually "provide a crucial clue as to just 'who' was running this entire 'hijack operation,'"³² for this was the key that led Hoagland to the Masons and the Magicians.³³ Indeed, all three groups could claim a justifiable interest in esoteric matters as a part of their pedigree, and thus, Hoagland and Bara concluded that, at a very early period even before the founding of NASA itself, these three groups made common cause and "*literally (stole) the entire space program* for themselves from the rest of all mankind – 'Space' is destined to remain the *sole possession* of only those with these 'proper bloodlines and perspectives'...but *not* for any of the rest of us."³⁴

d. The Biggest "Ritual Alignment" of them All

However, if there was a "common cause" and a covert agreement to "share space" that grew out of all three groups' well-known connections to and preoccupation with ancient esotericism, which group was, or became, the dominant one? Hoagland's and Bara's answer to that question are stunning, and chilling. Noting that two of the crucial landings, Surveyor 3 and Apollo 16 – the first of which had indeed helped fix the entire lunar landing ritual grid – actually occurred on April 20, 1967 and 1972 respectively, they drew the immediate reference:

April 20 was Adolf Hitler's birthday.

Again, put this in the context of the detailed and complex planning required to *land* a particular spacecraft on a particular day and time on another planet, and at a particular place. *Such landings could not be accidental.* Moreover, they also discovered that the Apollo 16 Lunar Excursion module was named "Orion," which, when combined with the obvious symbolism of a landing on Hitler's birthday, strongly suggested a "potential 'resurrection,' specifically on his *birthday*, of 'something' in the name of Hitler."³⁵

Given the esoteric ideology of Nazism itself, an ideology that, in Heinrich Himmler's "Ancestral Research Bureau" sought to trace

German ancestry back to the Aryan race they believed to have colonized Sumer and Egypt, the conclusion for Hoagland and Bara was inescapable, and it is best to allow them to tell it in their own words:

This new “ritual coincidence,” a second NASA mission *deliberately* landed on the day of Hitler’s birth, finally brought the astonishing set of alignments into crystal clear, sharp focus. For, by these repeated “ritual coincidences,” – commemorating the infamous Leader of the Third Reich – the key players behind this entire NASA lunar ritual were now overwhelmingly identified as none other than the NASA members of the former Reich. NASA – at the highest levels – had effectively been “taken over” from the Masons by Von Braun.

Further, it was now clear from the “ritual timing” of Kennedy’s critical address to that joint Congressional session (May 25, 1961), that the Nazis had carefully set up the President on what the *real* objectives of Apollo would become, including the insitu reconnaissance and return to Earth of artifacts from the ancient ruins that the Nazis somehow knew about and clearly viewed as being left –

By their own ancestors!

No wonder Kennedy was murdered, immediately after his repeated offer to share this priceless “Nazi heritage” with their worst enemies, the Russians, was finally accepted.³⁶

Nor can this conclusion, astonishing, stunning, and chilling as it is, and given the entire context of *this* book and my previous books on Nazi secret weapons and postwar survival, be too readily dismissed. In fact, it is the one conclusion *that most fits the wider tapestry of evidence* examined here and in those other books.

4. A Stunning and Chilling Scenario: The Implications of the Dark Mission Conclusions Regarding the Nazis

This all suggests a very carefully planned long-range scenario, carefully scripted in the last days of Hitler’s Third Reich. In what now

follows, I wish to make clear that the proposed scenario is my own, and not Mr. Hoagland's or Mr. Bara's, though it is certainly suggested by their own research, as well as my own previous research on the subject of Nazi secret weapons and the Bell.

Consider the careful long-range planning for and implications of the total scenario I have presented here and elsewhere. Bormann and Kammler plotted carefully to insure that the best rocket scientists would go to America, along with most of the plans and blueprints for advanced rockets, while the Soviets got hundreds of middle echelon draftsmen, technicians, and engineers who would allow the Russians to reconstruct the paper trail and begin their own space program. Bormann transferred priceless enriched uranium-235 for America's atom bomb program to the United States via the U-234, and using the security he knew would be afforded to that cargo, in all likelihood smuggled himself and Heinrich Müller to safety. Meanwhile, the noted German atomic scientist Baron Manfred Von Ardenne made his way to the Soviet Union, where he assisted the Russians on *their* atom bomb project, eventually becoming the only non-Russian to win the Stalin Prize for science – the Soviet Union's equivalent of the Nobel Prize – in recognition for his efforts in the Soviet bomb program. Similar “equal divisions” of the spoils of German technology in aeronautics were also engineered.

Bormann, however, saw to it that Kammler had direct control of Luftwaffe *Kampfgeschwader* 200, giving him control over Germany's last remaining JU 390, the only plane capable of flying a heavy load – the Bell and/or its priceless project documentation – from Europe to Latin America, where, curiously, we find after the war Richter's strange project involving plasmas and, ostensibly, “fusion,” and where we also find Martin Bormann according to the Argentine and FBI documents examined earlier. Succinctly stated, *Bormann saw to it that the Nazis kept the best technology, and its future development, to themselves.*

Additionally, we have repeatedly mentioned the “intelligence deal” between General Reinhard Gehlen and Allen Dulles, that turned nominal jurisdiction of Gehlen's vast spy network inside of Eastern Europe over to the nascent American CIA, effectively comprising its civilian charter at the outset, and effectively staffing the entire Soviet

analytical and operational desk of the CIA in its early years with a bunch of Nazis. The *deliberate* overestimation and disinformation by Gehlen's organization of Soviet military and economic preparedness for war helped fuel the Cold War. And given that the KGB is known to have "turned" several of Gehlen's agents into "double" agents for the Soviet Union raises the possibility that these agents in fact remained loyal Nazis all along, and were furthering a hidden goal of their own, very possibly passing disinformation back to the *Soviets* about *American* "war intentions and preparations, thus giving the Nazi International a network that penetrated and manipulated policy on both sides of the Iron Curtain, a hypothesis not without its own possibilities of reality, since the German reunification itself *was effected* by precisely such coordinated activity on both sides of the Iron Curtain.

Moreover, there is the Kennedy Assassination itself. As I averred in *The SS Brotherhood of the Bell*, the Gehlen organization may not only have taken a hand in the actual training of Lee Harvey Oswald for his "defection" to the Soviet Union – after all, who *else* had the experience of operations behind the Iron Curtain to the extent that Gehlen's organization did? – but there is also the matter of Kennedy's threatening to smash the CIA into a thousand pieces. This, coupled with his offer to go to the Moon jointly with the Soviet Union, took *direct aim* at *two* of the bureaucracies and fiefdoms into which Nazis had infiltrated: NASA, and the CIA. Moreover, such cooperation would have directly threatened the putative Nazi International with *exposure*.

And consider the other "fingers" pointing to Martin Bormann and his Nazi International.

There is Allen Welsh Dulles *himself*, a member of the Wall Street elite that helped establish the technology transfers between the United States and Germany, and the very elite that also helped to establish the enormous monster of the German cartel system between World Wars One and Two. Dulles, of course, became a director of the CIA, remained friends with Gehlen, and was *fired* by Kennedy for his part in the disastrously unsuccessful Bay of Pigs invasion of Cuba. Yet, even with these "conflicts of interest," Lyndon Johnson appointed him as a member of the Warren Commission

investigating Kennedy's death. And present with him as a member of that Commission was John J. McCloy, former Allied High Commissioner for occupied Germany, and a former lawyer for I.G. Farben's interests in America!

And then there is Wehrner Von Braun. Hoagland and Bara have strongly stated that the Nazi motivation for the recovery of alien technology from the Moon was not only a hidden agenda of the Apollo missions, but a real ideological objective of the Nazi Party. But there is more evidence of this fact than inference. As I pointed out in my book *Secrets of the Unified Field*, Von Braun was a prominent member, if not the *guiding force*, on the Project Orbiter Committee, the very Pentagon Committee that received The Varo Annotated Edition of Morris Jessup's *The Case for the UFOs*, the edition with its strange annotations regarding antigravity, the Philadelphia Experiment, and an ancient cosmic war fought in our own solar system.³⁷ By now, it should be obvious, that this, too, is not another "coincidence."

Small wonder, then, that neither District Attorney Jim Garrison, nor Oliver Stone in his celebrated movie, *JFK*, really knew how to deal with the Nazi connection.

And equally small wonder that the NASA Nazis were able to land significant lunar missions on Adolf Hitler's birthday, a celebration that, as has been seen, was observed by other Nazis in Argentina.

B The Real Apollo Missions

So why *did* the Apollo missions suddenly end with Apollo 17? After all, the rockets for Apollo 18 were already purchased and the money was already *spent*. Why, with the rockets ready, the astronaut teams ready, did America suddenly call off further Moon landings? Needless to say, the answers to this question have run the entire spectrum of unbelievability, from unbelievable government explanations that the "money" or the "interest" was no longer there, to unbelievable internet and conspiracy explanations that "ET" was already on the Moon, and basically told us "meddling humans" to "stay away."

1. Hoagland's Conclusions

In the Epilogue to *Dark Mission*, Richard C. Hoagland gives a much more believable and reasonable explanation for why Apollo was suddenly and by any accounts inexplicably cancelled. To put it succinctly, it was "Mission accomplished," Apollo had found what it was looking for. NASA "was sending astronauts to the Moon on an archeological reconnaissance mission, looking to find the lost power of the gods that may have been left lying around the lunar surface in the form of instrumentalities from eons past."³⁸ Hoagland and Bara state the case for the real reason for the abrupt termination of Apollo with a succinctness that belies the importance of their remarks:

In the years following JFK's assassination, when Apollo finally became an engineering reality, only nine successful Apollo missions to and from the Moon were carried out; only six of those were actually lunar landings.

Then (apparently), a critical number and type of lunar artifacts was successfully identified, and returned to Earth by the Apollo crews – at which point the entire Apollo Program was abruptly terminated with Apollo 17.

In our model, it was this successful completion of Apollo's secret mission and agenda, and not Congressional budget cuts, which was the real reason for this abrupt cessation of America's historic journeys to the Moon, and the primary reason no one has gone near the lunar surface for over 30 years.³⁹

2. Some Implications of Their Remarks in a Wider Context

This conclusion is both plausible and, from the standpoint of the data and analyses presented in their book, entirely reasonable and believable. But there is an implication to this conclusion that readers of *Dark Mission* may have missed, unless they bear in mind Hoagland's and Bara's integrated style of diction, where each point is meant to be viewed in the context and in direct connection to all other points in the book. Here Hoagland's conclusion should be

taken in the context of the theme of the three esoteric groups – Masons, Magicians, and Nazis – that vied for power and influence in the agency, namely, *that in seeking exotic artifacts and potential technology left by a prior interplanetary civilization on the Moon, each of these three groups was pursuing an agenda stemming from the esoteric teachings of those groups: that there once was a sophisticated and extremely ancient interplanetary civilization based in the solar system, and that it probably left artifacts of its sophisticated physics and technology on worlds in very close proximity to earth.*

Indeed, as I have noted throughout some of my previous books, one goal of such secret societies as the Masons was precisely to “turn the stream” and recover this ancient lost knowledge.⁴⁰ Certainly the same could be said of “the Magicians.” But most importantly, as I have argued elsewhere, the same *must* be said of the Nazis, since there is a preponderance of evidence that suggests that their most closely held secret weapons projects were attempts to recover aspects of this lost physics and science.⁴¹ By stating that the real goal of Apollo was “an archeological reconnaissance mission” to recover some of this technology, Hoagland is in fact arguing – in my opinion persuasively – that at the minimum the Nazis not only had obtained the mastery over NASA at this time frame in history, but that they were continuing, under its auspices and at the expense of the American taxpayer, their own closely held party ideology to recover aspects of that lost science and technology. The Nazis were, in short, not only continuing the agenda of the very secret societies and occultists that helped midwife the Nazi Party into existence, but continuing the investigation of the esoteric science and agenda of projects represented by the Bell. After all, as I point out in *SS Brotherhood of the Bell*, the Bell Project’s power plant designer, Dr. Kurt Debus, wound up as a flight director for NASA at Cape Canaveral during the heyday of the Apollo missions!⁴² And to celebrate the fact, they landed two Apollo missions on Hitler’s birthday, much like other Nazi veterans met in obscure hotels in Argentina every year on the same date!⁴³ *The pattern is the same.*

Nor does the possibility of some collaboration between the NASA Nazis and the NASA Masons and/or Magicians mitigate this view, for

a *modus vivendi*, a kind of “esoteric detente” could have been reached allowing each group to share in the spoils of esoteric knowledge and/or artifacts gained. But as Hoagland and Bara make clear, however, by the time of the Hitler’s Birthday Moon Landings, the Nazis have gained the upper hand in mission planning and agendas.

3. *The Wider Implications*

That fact, given the wider context of this book, means that *all* aspects of the wartime Nazi agenda were in fact intact and *being deliberately pursued* after the war by postwar Nazis, and this, in turn, is yet another argument that the Nazi ideology survived the war not only intact, but with enough organizational and fiscal health to continue those agendas – from the exploitation of conflict to the exploration and exploitation of space – without scarcely missing a beat.

And more importantly, it also indicates that the two track space program - the one with rockets for public consumption represented by Apollo (with its *own* hidden archaeological agenda), and the secret one with exotic physics and alternative technologies, represented by the Bell, Dr. Richter, and the presence of the Bell project’s power plant designer as key a NASA flight director, Dr. Kurt Debus — was alive and well.

¹ Richard C. Hoagland and Mike Bara, *Dark Mission: The Secret History of NASA* (Feral House, 2008), p. v.

² Hoagland and Bara, *Dark Mission*, p. ii.

³ See, for example, the songs by satirical song-writer-cum social commentator, Tom Lehrer, “The MLF Lullaby” and “Wernher Von Braun,” from the CD audio disk *That Was the Year That Was: TW3 Songs & Other Songs of the Year* (Warner), Tracks 2 and 13.

⁴ Hoagland and Bara, *Dark Mission*, p. 172.

⁵ *Ibid.*, p. v.

⁶ Hoagland and Bara, *Dark Mission*, pp. v-vi.

⁷ Hoagland and Bara, *Dark Mission*, pp. vi-vii.

⁸ *Ibid.*, p. vii.

⁹ Hoagland and Bara, *Dark Mission*, p. 199.

¹⁰ Ibid., pp. 199-200.

¹¹ Ibid., p. 200

¹² Hoagland and Bara, *Dark Mission*, pp. 200-201.

¹³ Ibid., p. 201.

¹⁴ Richard C. Hoagland, "Epilogue," from Richard C. Hoagland and Mike Bara, *Dark Mission: The Secret History of NASA* (Feral House, 2008), p. 201.

¹⁵ Ibid., p. 202, emphasis added.

¹⁶ For the Martian connection to Horus, see my *The Cosmic War: Interplanetary Warfare, Modern Physics, and Ancient Texts*, pp. 283-296.

¹⁷ Hoagland and Bara, *Dark Mission*, p. 204, emphasis in the original.

¹⁸ Ibid., p. 205, emphasis in the original.

¹⁹ Ibid., p. 206. For a discussion of the "Eye of Horus" and the "Falcon" as a reference to Horus, see again my *The Cosmic War*, pp. 285-294.

²⁰ Ibid.

²¹ Ibid., pp. 206-207.

²² Hoagland and Bara, *Dark Mission*, pp. 210-211.

²³ For Hoagland and Bara's summary of this physics, see *Dark Mission*, pp. 1-20.

²⁴ Another tetrahedral number, one might note!

²⁵ Ibid., p. 212.

²⁶ Ibid.

²⁷ Richard C. Hoagland, "Epilogue," from Richard C. Hoagland and Mike Bara, *Dark Mission: The Secret History of NASA* (Feral House, 2008), pp. 212-213.

²⁸ Ibid., p. 214.

²⁹ Ibid., emphasis in the original.

³⁰ Hoagland and Bara, *Dark Mission*, pp. 215-216.

³¹ Ibid., p. 219

³² Ibid.

³³ Ibid., see the discussion on pp. 224-236.

³⁴ Ibid., p. 247, emphasis in the original.

³⁵ Hoagland and Bara, *Dark Mission*, p. 253.

³⁶ Ibid., p. 254. Hoagland and Bara are referring to the fact that, on their reconstruction of space history, President Kennedy had proposed to Premier Khrushchev, in the aftermath of the nearly disastrous Cuban Missile Crisis, that the U.S.A. and U.S.S.R. jointly go to the Moon in part to defray the expenses each would incur as a separate program, and in part to share technology literally “with all humanity” on both sides of the East-West divide, as a plan to further world peace.

³⁷ See my *Secrets of the Unified Field*, pp. 67-76, 292-296.

³⁸ Ibid., p. 511.

³⁹ Hoagland and Bara, *Dark Mission*, pp. vii-viii.

⁴⁰ See my *Giza Death Star* (Adventures Unlimited Press, 2001), *Giza Death Star Destroyed* (Adventures Unlimited Press, 2005),

⁴¹ See my *Reich of the Black Sun* (Adventures Unlimited Press, 2004), pp. 161-180; *The SS Brotherhood of the Bell* (Adventures Unlimited Press, 2006), pp. 104-115, 192-241, *The Philosophers' Stone* (Feral House, 2009), .Part Three

⁴² See *The SS Brotherhood of the Bell*, pp. 155-159.

⁴³ See chapter ten of the present work.

Conclusions: An Interesting Timeline and a Possible Scenario

“There had to have been a level at which the US Government’s leaders identified with the Nazis, or at least admired them. There had to have been a point at which the crimes of the Holocaust were considered a minor problem, a kind of public relations nuisance, that was overshadowed by the glamour of the perfectly-run superstate of the Third Reich. There must have been an understanding that the ideologies of America and Nazi Germany were more alike than the ideologies of America and the Soviet Union. This is because there is just no other way to interpret what took place at the very end of the war; morally what transpired can only be considered a war crime itself.”

Peter Levenda¹

It is customary in books of this nature to recapitulate previous chapters in the form of a summary and conclusions that can be drawn from the evidence. Here, however, the summary and

conclusions suggest a scenario, which may be weaved together by considering all the various authors' research that I have outlined here as well as in my previous books on wartime Nazi secret weapons research, *Reich of the Black Sun*, *The SS Brotherhood of the Bell*, *Secrets of the Unified Field*, and *The Philosophers' Stone*. That scenario may best be summarized, not in a series of itemized conclusions, but by outlining the *timeline* of events. In doing so, I shall present the actual events themselves in normal type face, and my or others' interpretations of those events, whether conjectured or actual, in italics.

A. 1920s – 1930s:
*Alchemy, Esotericism, the SS, and the
Unified Field Theory Craze*

1. **1920s:** The Thule Gesellschaft and other secret societies help midwife the Nazi Party into existence; during the 1920s, there is a persistent and public interest in alchemy, and members of the Nazi Party, including General Erich Ludendorff, financially back the alchemist Tausend's alchemical experiments. This causes a public scandal and fraud trial in Germany, which is covered by the international press.²
2. **1920s:** At this same time period, scientists in Japan and more importantly, Germany, are investigating evidences of alchemical-like transmutations in the laboratory and publishing serious scientific papers on the subject, with many German firms taking out patents on various transmutation processes.³
3. **1921:** During this time period, German mathematician Theodor Franz Eduard Kaluza publishes the first hyper-dimensional Unified Field Theory of electromagnetism and gravitation, a theory that relied on a five-dimensional "cylindrical" geometry to achieve the unification. Einstein eventually backs publication of the theory in the journal of The

Prussian Academy of Sciences, and begins his own investigations of hyper-dimensional unified field theory.⁴

4. **1933-1935:** With the Nazi accession to power in 1933 and the formation of the *SS Ahnenerbedienst* by *Reichsführer SS* Heinrich Himmler in 1935, Nazi Germany becomes the first modern state to commit serious financial resources and personnel into the investigation of esoteric traditions for their potential military exploitation.⁵
5. **1924:** Nobel Laureate Dr. Walther Gerlach writes openly about scientific alchemy in a Frankfurt newspaper, calling openly for further funding for research into the phenomenon. Gerlach's specialty in physics is in rotating electromagnetic systems and gravity.⁶
6. **1928:** Einstein publishes a "full" version of his own thoughts on Unified Field Theory in an important paper in 1928. This version of the theory incorporates the "torsion tensor" with a geometry that spirals, folds, and pleats the fabric of space-time.⁷
7. **1933-1935:** Occultist Karl Maria Wiligut, whose writings contain alchemical and physics speculations as well as statements of belief in an extremely ancient Very High Civilization, becomes a personal advisor to Heinrich Himmler.⁸
8. **1935:** Hungarian electrical engineer Gabriel Kron publishes a paper demonstrating that anomalous phenomena in rotating electrical machinery and electrical networks can **only** be explained by recourse to Einstein's Unified Field theory. For this paper he wins the prestigious Montefiore Prize from the University of Liege in Belgium.
9. **1938-1939:** *Reichsführer SS* Himmler personally backs and sponsors the Schäffer expedition to Tibet. The German team actually gains entry to the Potala in Lhasa, and returns to Germany with the only complete copy of the ancient Tibetan epic, the *Kang Shuur*, said to contain information on a lost high civilization, to a western nation.⁹

From these considerations it will be evident that within the general German culture of the 1920s and 1930s, there was a current of profound social and scientific interest in alchemy and other forms of esotericism, and in the possible scientific and physics explanations for alchemical claims. As is also evident, this public interest translated into an organized effort within the SS to fund and investigate all avenues of esotericism for military exploitation. As I noted in Reich of the Black Sun, this bureaucratic culture issued in much more foolishness than successes, but it is also unlikely that the successes were ever publicized.¹⁰

Within this overall climate of scientific opinion, Kron's 1935 paper made obvious the implication that Unified Field Theory effects could be locally engineered on the laboratory bench. Thus, a powerful climate of opinion was created that, within the "mission brief" of Himmler's SS, probably found expression in the funding for the research of exotic physics. Similarly, Kron's paper would have attracted the attention of American "science projects Tsar" Vannevar Bush, President Franklin Roosevelt's science advisor. In all likelihood, these scientific impulses became the impetus for America's Philadelphia Experiment and Nazi Germany's Bell project, both of which are rationalizable from the same physics basis.

B. 1943-1945: Strange Events from the Middle to the End of World War Two

- 1. January – July, 1943:** A Japanese communiqué between Stockholm and Tokyo report that the Germans are using an "atom bomb" on the Eastern Front, and specifically mention their use in the Crimea and during the Battle of Kursk in July, 1943.¹¹ Otto Skorzeny in his memoirs also confirms the German use of fuel-air bombs in rocket artillery batteries during the German offensive on Moscow in 1941¹² In the wake of the Stalingrad debacle, many Nazi leaders quietly

begin evacuating liquid capital and other resources to neutral safe havens outside the Reich.

2. **ca. January 1943:** Other vague reports indicate the testing of a “scalar” weapon of some sort, most likely by Germany, on the southern Eastern Front in the aftermath of the Soviet encirclement of Stalingrad.¹³
3. **September – October, 1943:** The American full-scale version of the Philadelphia Experiment is performed, achieving its highly anomalous results of optical invisibility of an entire destroyed escort class ship.¹⁴
4. **July 20, 1944:** The Bomb plot against Adolf Hitler fails. General Otto Remer remains loyal to the Nazi Regime in Berlin, foiling the putsch attempt.
5. **ca. October 10, 1944:** Germany allegedly tests a nuclear bomb on or near the island of Rügen in the Baltic Sea; the test is witnessed by an Italian liaison officer to Wehrmacht headquarters, Luigi Romersa.¹⁵ Britain during this same time frame places the whole country on secret alert against the possibility of a German atom bomb attack, as postwar press reports revealed.¹⁶
6. **mid-1944:** Nazi Germany also tests a large “liquid air bomb” in eastern Germany or western Poland with a personal representative of Reichsführer Himmler present; the bomb’s shock wave flattens trees to a distance of 12 kilometers, making it an enormous liquid air bomb, or something else.¹⁷
7. **August, 1944:** Bormann orchestrates the Hotel Maison Rouge meeting with the blessings of Adolf Hitler to create a vast system of dummy and front corporations to evacuate liquid assets, crucial scientific and technical personnel, and actual technology outside the Reich. Bormann establishes a system of Nazi party liaisons with German corporations to enforce Party policies and agendas.
8. **March – April, 1945:** Bormann gives command over the Luftwaffe’s *Kamfgeschwader* 200 and its valuable Junkers 290 and 390 long range aircraft to SS General Kammler, head of Nazi Germany’s secret weapons projects, including the Bell.¹⁸

Kammler, the Bell, its project documentation, and the Junkers 390, last seen in Prague in April of 1945, go completely missing at the end of the war. Bormann's postwar presence in Bariloche according to the Argentine documents, and the presence of Richter—and perhaps even Hitler himself—in that region of Argentina—strongly argue that the Bell and Kammler went, not to the United States, but to Argentina.

9. **April – May 1 or 2, 1945:** The U-234, a cargo U-boat, departs Germany with a load of enriched uranium-235, infrared proximity fuses, their blueprints, and inventor, Dr. Heinz Schlicke. The U-boat's movements after departing Norway make it highly plausible that it returned covertly to Germany to pick up Martin Bormann and Heinrich Müller. During the period that the U-boat's logs are suspiciously lacking in detailed reports of its movements, there would have been time for it to convey Bormann and Müller to Nationalist Spain, where, in turn, they went on to Argentina. In the same time frame, Von Braun and many top Nazi rocket scientists surrender to American forces, while the Soviet Union gets many middle echelon rocket technicians. Similarly, Baron Manfred Von Ardenne decides to cooperate with the Soviets in their atom bomb program. The Soviet Union also obtained Dr. Hellmann's radar team, which had discovered the principles of optical phase conjugation in late war experiments. These become the basis of postwar Soviet scalar research.¹⁹

In the scenario outlined in this book, Bormann had negotiated the surrender of the uranium and infrared proximity fuses to the United States, and, knowing that the Americans would "protect" the U-boat, escaped in it. He similarly arranged for a tidy division of Nazi Germany's rocket and nuclear spoils between the eastern and western blocs. Subsequent postwar Nazi and Neo-Nazi groups exploit the East-West tensions for their own purposes, which of course culminated in German reunification – basically an annexation of East Germany by West Germany – in 1989-1991.

10. **Late April – Early May, 1945:** Advance units of General George S. Patton's American Third Army enter Czechoslovakia and the Skoda works at Pilsen, as well as other secret installations of Kammler's "secret weapons empire." While the SS in all probability "cleaned" these installations of documents and equipment, nonetheless it would have been readily apparent to American military intelligence officers with those units that these installations, about which the Allies knew almost nothing, were centers of deeply black research projects. Patton, as the commander of the Third Army, would have been one of the few people in the American command structure with a comprehensive picture of these projects. He subsequently dies under mysterious circumstances.

11. **1945:** General Reinhard Gehlen and OSS spymaster Allen Dulles work out the deal keeping German military intelligence intact and turning it over to the nominal control of the future CIA. Thus, German military intelligence is the only organization in the postwar world with significant penetration into the Eastern and Western Blocs and their security services, making possible a coordination of actions on both sides of the Iron Curtain when situations require it.

12. **Late April – Early May, 1945:** Several Tibetan monks in SS uniforms found dead by Russian soldiers entering Berlin.

This requires some commentary. Since the 1938-1939 Schäffer Expedition is known not to have brought out large numbers of Tibetan monks, but only a copy of the Kang Shuur, the question becomes, when were these monks smuggled out of Tibet into Nazi Germany, by what route, and for what purpose? The most likely possibility was sometime around the period of the massive German offensive on the southern Russian Front in the summer of 1942. It is a little known fact that the Wehrmacht sent armed long-range reconnaissance units as far east as Astrakhan on the northern Caspian Sea, but beyond sewing confusion behind Russian lines, there was little military value in such an operation.²⁰ However, it is possible that commando-engineer units of the Waffen SS might have been included in

these units, and, once the units had penetrated as far east as was operationally safe, the commando units would have been released to continue onward through Kazakstan and on into Tibet, utilizing Nazi intelligence contacts in these Muslim areas to smooth their passage through hostile territory. Once in Tibet, a makeshift airfield could have been constructed able to handle long-range aircraft. The Tibetans would have then been flown back to Germany. While a hazardous enterprise, to be sure, it would have been far safer than attempting to smuggle monks out through British India and back to Germany via U-boat, which, in any case, would have required more trips than would have been required by even one of the large Junkers 290s or the enormous Junkers 390s. As for the purpose of such an operation, this is relatively transparent, for such expertise would have been required if Himmler's SS was to translate its copy of the Kang Shuur completely and accurately.

13. May 7 and 8, 1945: German Armed Forces under the command of *Reichspräsident* and *Großadmiral* Karl Dönitz surrender to Allied forces unconditionally at Reims, France, and in Berlin. No representative of the Nazi Party or Bormann's Party Chancellery itself is present at either surrender ceremony. *Indeed, the **absence** of any such presence at either surrender ceremony is in itself very loose corroboration that Bormann – now aboard the U-234 bound for Spain – was nowhere to be found.*

C. 1946-1961: Postwar Shenanigans

1. Early 1946: American commando teams enter Czechoslovakia to "recover documents" and a minor international incident ensues as Czechoslovakia protests. America allegedly returns the documents.

As I argued in Secrets of the Unified Field, declassified American documents concerning this incident make it clear that the Czech government did not believe the American explanation

that this incursion was to recover documents pertinent to the war crimes trials, which Czechoslovakia no doubt would have turned over if a proper request had been made. Instead, the Czech government insisted that the documents had to do with sophisticated German radar technology. Close examination of the documents also reveals confusion in the upper echelons of the American command structure, since no one knows who gave the order for the secret incursion, nor why. There are two possible ways to reconcile all these points: 1) the American incursion was ordered by the OSS and for its own purposes. Given the contacts with American corporate interests represented by OSS spymaster Allen Dulles, the incursion may have been to recover technological documents for his corporate masters; or 2) the incursion was a “false flag” operation being run by units of the SS, wearing American uniforms, to recover essential project documents and spirit them out of Germany. Either possibility, without further evidence in this regard, is in my opinion equally probable.

2. July – September 1947: A strange and exotic craft crashes and is recovered by U.S. military personnel near Roswell, New Mexico. According to the so-called Cooper-Cantwheel Majic-12 documents, a full U.S. Air Force investigation occurs, which includes the resident Nazi Paperclip rocket scientists in New Mexico. Publicly the story is put out that the U.S. has recovered a “flying saucer” on the orders of the base commander, Col. William Blanchard (later four star general Blanchard). This story is refuted days later by other U.S.A.F. personnel including General Roger Ramey.

As I argue in The SS Brotherhood of the Bell and in my Reich of the Black Sun, however, all the internal evidence of these documents argues that the recovered technology, while exotic, was not exotic enough to be extraterrestrial. So what caused the panic in the American military? As outlined in those books, the technological descriptions of the craft, if they are to be believed, point clearly and inexorably to similar developments in Nazi Germany. Thus, the panic becomes understandable, for if something Nazi was able to enter American airspace over our

most sensitive military installations in 1947 with impunity, then that meant that someone, somewhere in the world was continuing an independent development of those wartime Nazi secret projects.²¹ Some UFOlogists explain Truman's signing of the National Security Act of 1947, which created the CIA and NSA, as a response, in part, to this "alien incursion." But as I also point out in The SS Brotherhood of the Bell, the term "National Security Agency" is a direct translation of Himmler's Reichsicherheitshauptamt, which was also a "central intelligence agency" clearing house.

3. **mid-1948:** The FBI gains reports of Bormann's survival in Bariloche, Argentina, and President Truman, at the request of Supreme Court Justice Jackson, authorizes Hoover's FBI to investigate the matter. *As noted in this book, this is peculiar, since President Truman had signed the 1947 National Security Act into law, which gave foreign intelligence operations to the jurisdiction of the CIA, not the FBI. However, if Truman suspected that the CIA had already been compromised by Nazis, the choice of the FBI makes perfect sense.*
4. **1949:** The Western Allies – Britain, France, and the United States, grant sovereignty to the West German Federal Republic and Konrad Adenauer becomes the first postwar German chancellor. General Gehlen's spy organization becomes Germany's *Bundesnachrichtendienst* and, for all intents and purposes, the nucleus of NATO intelligence as well. Gehlen deliberately misinforms the United States of Soviet strength and intentions, thus helping to exacerbate the Cold War.
5. **1951:** Argentine dictator Juan Perón precipitously announces that Argentina has learned to control thermonuclear fusion, citing his secret project at Huemul under the direction of Nazi physicist Ronald Richter. The suspicions raised by the international scientific community compel Perón to establish an investigative commission, which, aided by Richter's dubious behavior in pointing out his own project's scientific deficiencies, force Perón to close down the project after he

calls on help from SS officer and former Farben corporate executive, Prince Bernhard of the Netherlands. Richter is openly ridiculed in the scientific press. During this same time frame, Argentine intelligence documents place Bormann in the same environs of Bariloche as Richter's fusion project.

6. **1952:** The U.S.A. tests the first hydrogen bomb, code-named "Mike". The detonation exceeds pre-test calculated yields by almost four megatons, strongly suggesting another form of energy was being tapped by the device.
7. **1952:** Nasser takes power in Egypt, and imports German experts from the Nazi International and with the backing of the West German government. These include Skorzeny, Remer, Schacht, and Voss, i.e., include connections to the security, financial, and technological aspects of the Nazi Reich. These in turn train Nasser's security forces, army, and translate Nazi "classics" into Arabic.
8. **1956:** The United States Air Force shows a sudden and secret interest in the work of Dr. Ronald Richter, long after Perón had shut down Richter's "fusion" project. Richter's ideas clearly involve more than fusion, but use fusion to achieve manipulation of control over what Richter calls "zero point energy."
9. **1955-1958:** Carlos Miguel Allende writes his letters to Dr. Morris Jessup concerning the Philadelphia Experiment and Einstein's (1928) unified field theory, while the Office of Naval Research and its Project Orbiter Committee receive copies of Jessup's UFO book curiously annotated with notes referring to the experiment, to anti-gravity, and an ancient cosmic war. The Navy has one of its contractors print up a small run of Jessup's book with the annotations, which becomes known as the Varo Edition. This is circulated to its "top people," one of whom may very likely have been Wehrner Von Braun.²²
10. **ca. 1954-1960:** Wehrner Von Braun allegedly visits and corresponds with German physicist Burkhardt Heim, whose six-dimensional spin-oriented and fully-quantized theory of space-time was first openly publicized in West Germany in 1954. Heim's research at that period was sponsored by the

German arms and aerospace firm, Messerschmitt-Belkow-Blohm.²³ *Note now a pattern that has emerged: whenever one encounters an “off-the-books physics” dealing with rotating systems, rotating plasma, anti-gravity or exotic physics, one finds Nazis at almost every turn. Von Braun’s interest in Heim’s theory, and in other processes that cannot be detailed here, is part and parcel of his interest in anomalies he had encountered during this same time frame.*

11. **May 1961:** President John F. Kennedy announces the goal of landing a man on the Moon before the decade is out to a joint session of Congress.
12. **1962-1963:** President Kennedy quietly proposes to Premier Khrushchev that the United States and the Soviet Union cooperate in reaching the Moon. Shortly before his assassination, according to Hoagland and Bara, Khrushchev accepts.
13. **Nov. 23, 1963:** President Kennedy is assassinated by a conspiracy in Dallas while on a campaign swing through the state.
14. **1961-1965:** Russian and American space program launch schedules shows signs of deliberate though covertly organized coordination.²⁴
15. **1965:** American physicist and electrical engineer Philo Farnsworth reports a sustained fusion reaction of about half a minute in a device no bigger than a softball. After an initial flurry of press attention, Farnsworth’s corporate sponsor, I.T.&T., a corporation with known Nazi wartime connections, shuts the project down.
16. **Dec. 9, 1965:** A UFO crashes near Kecksburg, Pennsylvania after a flight from northwest Canada down over Michigan and Ohio which is observed by several witnesses. Witnesses on the ground in Pennsylvania report that the U.S. military and NASA officials arrived within mere hours after the crash, cordoning off the area and removing the object. The object resembles the Nazi Bell on a number of crucial data points regarding its dimensions, sound, shape, and housing.²⁵

17. **1967:** New Orleans District Attorney Jim Garrison initiates his investigation of the Kennedy Assassination, and quickly uncovers many Nazi connections, including Clay Shaw himself, who vetted Paperclip Nazis.
18. **July 20, 1969:** Apollo 11 lands on the Moon on the twenty-fifth anniversary of the unsuccessful assassination and coup attempt on Adolf Hitler's life. *To my knowledge, not even Mr. Hoagland had mentioned this significant "ritual alignment" and its implications, though, within the context of his own model and conclusions, they are clear enough: the very first human landing on the Moon was on a significant "Nazi holiday," when the unsuccessful Bomb Plot against Hitler was foiled in large part by German General Otto Remer. This is again a clear signal that within the three groups vying for ultimate control of NASA, it was the Nazis who were most successful in exercising control over mission planning.*
19. **1970:** The "Torbitt Document" alleging the involvement of Wehrner Von Braun in the Kennedy Assassination first appears.
20. **1973:** The CIA, IT&T, and the Nazi colony "Cologne Dignidad" in Chile cooperate in the overthrow of Chilean Marxist Salvadore Allende. Cologne Dignidad subsequently helps train Chilean dictator Pinochet's intelligence service.
21. **1978-19879:** Vela satellite detection of a large nuclear-like detonation in the Indian Ocean prompts President Jimmy Carter's Administration to accuse South Africa of having detonated an atom bomb. Subsequent research discloses that West Germany was the secret technological partner that supplied isotope separation technologies and German technicians to South Africa and Israel to use the latter countries as proxies to test its own bomb.[26](#)
22. **1989-1991:** German reunification exhibits careful coordination between Bonn and Neo-Nazi groups in Eastern Europe. Post-reunification Germany moves quickly and effectively to break up Czechoslovakia and Yugoslavia, even to the point of sending German troops to protect Croatia,

which, over NATO, UN, and European opposition, it had unilaterally recognized diplomatically.

The significance and importance of this timeline lies not only in the overall picture and scenario of the postwar survival of the Nazi International and the comprehensive nature of its activities that it paints, but also in the fact that one may dispute significant numbers of the individual components of this scenario, while leaving its overall structure and implications intact. Indeed, while I have argued in this book and elsewhere that Bormann, Müller, and Kammler survived the war, the overall scenario itself does not require that they did so. The overall scenario as such only argues that in order for all these various activities to have been pursued – especially with evident coordination as in the case of the Egypt affair, the Richter fusion project affair, Nazi activities inside of NASA, or the German reunification itself – that there had to have been in place a tight-knit organization with very clear and secure channels of communication, chains of command, and financing on *both* sides of the Iron Curtain.

This, of course, does not excuse the *American* side of this story, for clearly, the early formation of the German military-industrial complex that so tragically dominated the events of the Second World War – and to that extent, the postwar world – were not only of German, but American, making.

Many might be inclined to dismiss the contemporary relevance of this scenario even while they may be inclined to grant its plausibility. After all, by now Bormann and Company, if they survived the war as I believe the evidence suggests, are long dead. Surely their successors would, by now, be rather tired of “Nazi fun and games” and be more about the serious business of increasing profits and extending their influence in more benign, legitimate, and respectable ways. But I am bold to suggest that this is a temptation that must be avoided at all costs for one very plain and patent reason: Bormann, Müller, and Kammler themselves, not to mention Schacht, Skorzeny, Voss, Remer, and all the other parade of wickedness and evil we have surveyed here, were all themselves *bureaucrats*. They were, in a word, “professional” Nazis. Nazism as an ideology is about but one thing: gain power over as much of the world by whatever means

possible, and hold on to it. It was an ideology that maintained there were far too many “useless eaters” of “dubious racial background” in the world – much like the pronouncements one hears coming from the global corporate elite today – and busily set out to do something about it.

What has been surveyed here – and it is *only* a survey – indicates precisely a bold design to exploit conflict in the most subtle ways to promote their agenda, to control and develop advanced energy technologies with a variety of applications – field propulsion, “free” energy, and a horrendous weaponization potential – and monopolize them for its own group interest, an interest perhaps best exemplified in their determined effort to conquer the high ground of space itself, monopolize and control whatever artifacts and technologies they found there, and with them, and from the high ground of space itself, to dominate the earth through a shadowy multi-ethnic international organization of international finance and criminal activity, centered around a solid German core.

If, as Mr. Hoagland and Mr. Bara argued, Apollo 10 was delayed simply because “it was not the proper time,” than that puts all of Hoagland’s arguments concerning the ritual alignments of Apollo 11 into an even darker conspiratorial context.

Thus, when Neil Armstrong announced that the Lunar Excursion Module had touched down on July 20, 1969, onto the lunar landscape on the twenty-fifth anniversary of the failed bomb plot against Hitler, he probably never even noticed the high irony of his statement, “the eagle has landed,” for it was someone else’s eagle – one with a swastika surrounded by oak leaves clutched in its talons – that had filed the flight plan.

¹ Peter Levenda, *Sinister Forces: A Grimoire of American Political Witchcraft: Book One: The Nine* (Trine Day, 2005), p. 134.

² See my *The Philosophers’ Stone* (Feral House, 2009), chapter 11.

³ Ibid.

⁴ See my *Secrets of the Unified Field*, pp. 1-15

⁵ See my *Reich of the Black Sun* (Adventures Unlimited Press, 2004), pp. 172-180.

⁶ See my *The SS Brotherhood of the Bell* (Adventures Unlimited Press, 2006), pp. 148-151.

⁷ See my *Secrets of the Unified Field*, pp. 1-17.

⁸ See my *The Philosophers' Stone* (Feral House, 2009), chapter 11.

⁹ Various books have been published about this expedition, most of them mentioning the copy of the *Kang Shuur*. But the only coverage of this event within the wider occult culture within the Third Reich is Peter Levenda's *Unholy Alliance*.

¹⁰ See my *Reich of the Black Sun*, pp. 168-170

¹¹ Ibid., pp. 43-55

¹² See my *The SS Brotherhood of the Bell*, pp. 23-27

¹³ See my *The Giza Death Star Deployed* (Adventures Unlimited Press, 2003), pp. 109-112.

¹⁴ See my *Secrets of the Unified Field*, pp. 102-222.

¹⁵ See my *Reich of the Black Sun*, pp. 78-80.

¹⁶ Ibid., pp. 72-73.

¹⁷ Ibid. pp. 191-192

¹⁸ See my *Giza Death Star Deployed*, pp. 122-125.

¹⁹ See my *SS Brotherhood of the Bell*, pp. 225-227.

²⁰ The only account I am familiar with in the English language of this operation is German military historian Paul Carrell's *Hitler Moves East: 1941-1943*.

²¹ See my *Reich of the Black Sun*, pp 274-330; *SS Brotherhood of the Bell*, pp. 311-384.

²² See my *Secrets of the Unified Field*, pp. 292-296.

²³ See my *The Philosophers' Stone*, chapter 13. This contact highlights what Von Braun himself was up to, and why, during this same time period. See Richard C. Hoagland, "Von Braun's 50-Year-Old Secret," www.enterprisemission.com. Needless to say, there is much more going on here than even Mr. Hoagland alludes to in his paper, a story which we both hope to collaborate on in the future in telling. Mr. Hoagland has been gracious enough to share some of his research and the scientific papers it is based upon with me. Suffice it

to say, he is the best one to tell this aspect of the story, and we both hope to pool our resources in the future to do so.

²⁴ See my *SS Brotherhood of the Bell*, pp. 120-123.

²⁵ See my *Reich of the Black Sun*, pp. 331-344.

²⁶ See my *Reich of the Black Sun*, pp 268-9; and *SS Brotherhood of the Bell*, pp. 240-1, n.76.

✠ Bibliography ✠

Agoston, Tom. *Blunder! How the U.S. Gave Away Nazi Super Secrets to Russia*. Dodd, Mead & Company. 1985.

Aris, Ben, and Campbell, Duncan. "How Bush's Grandfather Helped Hitler's Rise to Power," *The Guardian*, Saturday, September 25, 2004, www.guardian.co.uk/world/2004/sep25/usa.secondworldwar.

Ash, Timothy Garton. *In Europe's Name*. Random House., 1993.

Balseiro, Dr. José A. "Report About the Experiments of Dr. R. Richter, according to what was Witnessed by Me During the Visit made to the Atomic Energy plant at Isla Huemul, from 5 to 8 September 1952," www.ib.edu.ar/informes-huemul/reports-heumul-principal.html

Balseiro, Dr. José A. "Report of Dr. José Antonio Balseiro Referring to the Inspection Carried out in Isla Huemul in September 1952," Buenos Aires: National Atomic Energy Commission, 1988, Nuclear Energy: History: Argentine: 621.039(091)(82)

Breitman, Richard, Goda, Norman J.W., Naftali, Timothy, Wolfe, Robert, eds., *U.S. Intelligence and the Nazis*. Cambridge University Press. 2005.

Childress, David Hatcher, and Vesco, Renato. *Man-Made UFOs: 50 Years of Suppression*. Adventures Unlimited Press. 1994.

Cooper, Harry. "Argentina's Place in the War," KTB #209 *Sharkhunters: the Official Publication of the U-Bootwaffe*.

Cooper, Harry. "Argentina's Place in the War," KTB #210: *The Official History Publication of the U-Bootwaffe*, Volume 26 July 2008 Number 5, Sharkhunters.

Cooper, Harry. "Plastic Surgery Clinic... in 1945," KTB #209, *Sharkhunters: the Official Publication of the U-Bootwaffe*.

D.M. Ladd to Hoover, 15 May 1948, NA, RG 65, 65-55639-(1-24), box 38.

de Velasco, Don Angel Alcazar. *Escape from The Bunker*, ed. Harry Cooper. Poison Pen Publishing. 2004.

Farnsworth, Philo T. "Method and Apparatus for Producing Nuclear-Fusion Reactions," U.S. Patent 3,386,883.

Farrell, Joseph P. "Does This Ring the Bell?" (February 19, 2008), www.gizadeathstar.com

Farrell, Joseph P. *Reich of the Black Sun: Nazi Secret Weapons and the Cold War Allied Legend*. Adventures Unlimited Press. 2004.

Farrell, Joseph P. *Secrets of the Unified Field: The Philadelphia Experiment, the Nazi Bell, and the Discarded Theory*. (Adventures Unlimited Press. 2008.

Farrell, Joseph P. *The Cosmic War: Interplanetary Warfare, Modern Physics, and Ancient Texts*. Adventures Unlimited Press. 2007.

Farrell, Joseph P. *The Giza Death Star Deployed: The Physics and Engineering of the Great Pyramid*. Adventures Unlimited Press. 2003

Farrell, Joseph P. *The Philosophers' Stone: The American "Gold," The Soviet "Mercury," and the Nazi "Serum."* Feral House. 2009.

Farrell, Joseph P. *The SS Brotherhood of the Bell: NASA's Nazis, JFK, and MAJIC-12*. Adventures Unlimited Press. 2006.

Geoffrey Brooks, "Report on Three Incidents Suggestive of Invisibility of German Submarines to Visual and Electronic Detection between 27 March and 4 July 1945," Personal communication to the author, July 4, 2008. Goñi, Uki. *The Real ODESSA: How Perón Brought the Nazi War Criminals to Argentina*, Revised Edition. London: Granta Books. 2002.

Goodrick-Clarke, Nicholas. *Black Sun: Aryan Cults, Esoteric Nazism, and the Politics of Identity*. New York University Press. 2002

Greer, Steven M., M.D. *Disclosure: Military and Government Witnesses Reveal the Greatest Secrets in Modern History*. Crozer. Virginia. 2001

Hahn, Dr. Paul-J. "Ball-Lightning: A HF Cavity Resonator?", www.p-j-hahn.de/kugelblitz2.html.

Hoagland, Richard C., and Bara, Mike. *Dark Mission: The Secret History of NASA*. Feral House. 2008.

Hoagland, Richard C. "Epilogue," from Richard C. Hoagland and Mike Bara, *Dark Mission: The Secret History of NASA*. Feral House. 2008.

Hydrick, Carter Plymton *Critical Mass: How Nazi Germany Surrendered Enriched Uranium for the United States' Atomic Bomb*. Whitehurst and Company. 2004.

Karlsch, Rainer. *Hitlers Bombe*. DVA, Germany, 2005.

Lee, Martin A. *The Beast Reawakens: Fascism's Resurgence from Hitler's Spymasters to Today's Neo-Nazi Groups and Right-Wing Extremists*. Routledge. 2000.

Levenda, Peter *Sinister Forces: A Grimoire of American Political Witchcraft: Book One: The Nine*. Trine Day., 2005.

Manning, Paul. *Martin Bormann: Nazi in Exile*. Lyle Stuart. 1983.

Marrs, Jim. *The Rise of the Fourth Reich: The Secret Societies that Threaten to Take Over America*. William Morrow. 2008.

Michael, George. *The Enemy of My Enemy: The Alarming Convergence of Militant Islam and the Extreme Right*. University Press of Kansas. 2006.

No author, "Double Check," *Time Magazine* (June 4, 1952), www.time.com/time/magazine/article/0,9171,858087,00.html?iid=chix-sphere.

No author, "Peron is Irked By Atom 'Find' Disbelievers: Scientist says He Know H-Bomb Secret, Told Not To Make It," *The Washington Post*, March 26, 1951.

No author, "Tried to Get Richter Into U.S., Engineer Says," *The Washington Post*, March 28, 1951

No author, "U.S. Nuclear Experts Doubt Peron Claim of New Way of Controlling Atom Energy," *The Washington Post*, March 25, 1951.

No author. "Brzezinski Backs NATO Expansion," AP Online, December 7, 1997.

No author. "Huemul Project," *Wikipedia*, en.wikipedia.org/wiki/Huemul_Project,

No author. "Perón's Atom, *Time Magazine*, Monday April 2, 1951.

www.time.com/time/magazine/article/0,9171,814503,00.html?pro_moid=googlep.

No author. "Report on the replies of Dr. Richter," www.ib.edu.ar/informes-huemul/reports-huemul-principal.html.

No author. http://truedemocracy.net/td2_1/Oklahoma/html.

Richter, Dr. Ronald. "Air Intelligence Information Report IR-79-56," National Archives and Records Administration.

Richter, Dr. Ronald. "Air Intelligence Information Report IR-80-56." National Archives and Records Administration.

Schmidt, Reinhold O. "The Reinhold O. Schmidt Story: Cosmic Secrets Exposed: Edge of Tomorrow: The True Account of Experiences with Visitors from Another Planet," <http://galactic.to/rune/reinhold.html>.

Stevens, Henry. *Hitler's Suppressed and Still-Secret Weapons, Science, and Technology*. Adventures Unlimited Press. 2007.

Stevenson, William. *The Bormann Brotherhood*. Harcourt Brace Jovanovich. 1973.

Sutton, Anthony. *Wall Street and the Rise of Hitler*, http://reformed-theology.org/html/books/wall_street/introduction.htm

Thorn, Victor. "The OKC-Elohim City Conenction,"
www.wingtv.net/elohim.html.

Witkowski, Igor. *Czwarta Rzesza: Poszukiwania Fortuny
Nazistów* Warsaw. 2005.

Witkowski, Igor. *The Truth About the Wunderwaffe*. European
History Press. 2003.

✠ Appendices ✠
Documents from Dr. Richter's U.S.
National Archives File

- 1. Dr. Richter's Scientific Explanations of his Physics Investigations*



3. Professional Field or Occupation: Include specialized fields of work or interest.

experimental and applied physics,

analysis of stress and vibration under extreme thermo-dynamic and mechanical conditions (hypersonic flight conditions, radiation corrosion, a.s.o.);

development of new materials of construction for rocket and jet motors, nuclear propulsion systems, a.s.o., to be produced in shock-wave- and ultra-sound-controlled arc melting furnaces,

high-pressure plasma physics and plasma implosion analysis, shock-wave physics and chemistry, interested in rocket and jet plasma analysis, solar plasma physics,

analysis of nuclear reactions in chain-reacting fission and fusion plasma sources,

development and testing of plasma-type, pulsed-controlled fission and fusion reactor systems,

development and testing of propulsion reactor systems,

experimental approaches to new concepts,

development and testing of highly-turbulent, magnetic-field-controlled fission and fusion plasma systems,

experimental approach to solar flare conditions and to the explosion-tendency of the solar plasma, ultraviolet excess analysis,

excitation of space structure by pulsed-controlled plasma implosion, testing the limitations of quantum mechanics and quantum dynamics,

experimental approach to the unified field theory and to the velocity of propagation of gravity, a.s.o.

DECLASSIFIED
Authority EO 12958

APR 26 1999

Chief, Declass. Br. 448
Dir. & Rec. Div. W-3

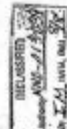

4. Education: List in detail the name and location of all secondary schools, trade schools, colleges or universities together with the dates of attendance. Give also the major subjects or courses studied, date and type of degree or diploma awarded. Include title and brief description of thesis, name of professor under whose direction it was completed.

1921-1927 secondary school Eger, Bohemia, Czechoslovakia,
(Oberrealschule)
1928-1934 German University Prague, Bohemia, Czechoslovakia,

studying experimental physics, theoretical physics, mathematics, astrophysics, geophysics, and chemistry,
especially interested in quantum physics, nuclear physics, space-time structure physics, earthmagnetism, gravimeter systems, solar radiation analysis,

thesis: 'Untersuchungen an Sperrschichtphotosellen mit weichen Röntgenstrahlen', (Investigations on photo-voltaic cells by soft X-rays), under supervision of Prof. Reinhold Fuarth (now Birkbeck College, London), and Prof. Otto Blinn (now University of Vancouver),

an electron beam, produced by thermal electron emission and electrostatic-field-induced acceleration, properly deflected by a magnetic field to shield out the light quantum emitted by the electron-emitting cathode, was striking an anti-cathode of copper or aluminum, thus generating bremsstrahlung quanta and (depending on the accelerating voltage applied to the beam electrons) characteristic X-ray quanta,

to prevent absorption of the soft X-ray quanta, the photo-voltaic Cu₂O-type cells were placed inside of the high-vacuum, cathode-ray-generating tube,

the photo-electric current was plotted against the accelerating voltage (5 - 30 kv),

this work was extended to other types of photo-voltaic cells by Hans Felsinger, published in 'Annalen der Physik', 29 (1937) 61,

graduated on March 2, 1935, Dr. rer. nat.

in 1935 and 1934, I was experimenting in my private research laboratory at Falkenau a.d. Eger with the Becquerel effect and was studying the interaction of blue and violet light with the discharge mechanism of a low-pressure neon gas ~~with~~ ^{with} a periodically charging and discharging condenser, (these studies became the basis for a nuclear reaction rate-analyzing method which I was developing in 1946 - 1951),

APR 26 1955



ban-Saegraben No. 47, Steiermark, Austria). We put together instruments and installations and were establishing a research laboratory at the 'Carabus-Kolbe', Muenchhof, near Falkenstein a. d. Elbe, (employing 3 assistants, income varying between 1,000 and 5,000 CS crowns).

development of the concept for an image-converter-like activity-contrast microscope,

by scanning the catalytically active border surface first with a proton beam (thus producing an activity-proportional adsorption contrast) and then 'evaporising' the adsorption contrast by scanning with a beam of electrons, a television-like contrast image can be achieved by modulating the television beam with the scanning signals,

for the first time, it became possible to see and to photograph true activity contrasts, (under the microscope and electron microscope, only structural details can be seen, in general not being identical with activity contrasts),

development of a continuously operating activity analyzer, based on the skin effect of high-frequency-energy absorption,

by developing this method, for the first time it became feasible to analyze the activity of border surfaces in action,

the continuously activity-analyzed activation of catalysts provided a considerable improvement of the efficiency of industrial catalysts,

pure magnesium, after having been activated by an activity-analyzed physical process, develops a considerable adhesion when coated with zinc electrolytically,

based on this activated adhesion, a new type of light weight storage battery was developed, the cathode being formed by activated magnesium carriers coated with electrolytically deposited layers of zinc,

charging and discharging of the cathode is provided by depositing and re-dissolving a certain amount of zinc, the amount of zinc being determined by the capacity of the nickel-peroxide-anode, cell voltage 1.8 volts,

The activation and analysis of activated catalysts, and the development of a light weight storage battery formed the basis of most of the research contracts until August, 1949.

Still in 1956, I was also doing private research work and design studies on arc furnace systems.

When studying self-stabilization of a reflector-controlled arc plasma by instantaneous overloading, explosion-like plasma ~~DECLASSIFIED~~ have been observed, generating a superposition of powerful radiating ~~subsonic~~ reflected plasma shock-waves.

APR 26 1958

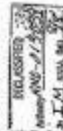

discovery of a magnetic-field-controlled feed-back loop between shock-wave-induced plasma turbulence and plasma-turbulence-induced promotion of shock-wave-generating plasma explosion,

on that basis, I was intending to develop a completely new class of shock-wave-controlled arc melting furnace and chemical shock-wave reactor, about 80 per cent of the electrical energy fed into the arc plasma system can be converted into the energy of plasma shock-waves and in shock-wave-induced ultra-sound,

for the first time, a magnitude of thousands and ten thousands of kilowatts of ultra-sound per reactor unit can be achieved, (the magnitude of ultra-sound-generating electronic equipment still being in the range of about 300 watts of ultra-sound per equipment,

thus, I was developing the most powerful source of ultra-sound, perhaps the most striking feature of such a shock-wave-controlled melting furnace consists in the feasibility of creating ultra-sound-induced metal alloys and ceramic-metal-alloys, by overcoming the limitations of the thermal solubility,

on that basis, it is intended, to develop series of new materials of construction especially for jet and rocket engines, and for nuclear propulsion systems, under hypersonic flight conditions,

a shock-wave-controlled arc plasma departs considerably from thermodynamic equilibrium; still in 1936, it was intended to analyze non-equilibrium thermodynamics in shock-wave-controlled plasma zones by employing plasma-collision-induced nuclear reactions,

In August, 1937, by Dr. Apfelbeck's arrangements, I went to Thuringia, Germany, to meet Staatsrat Otto Eberhardt, a friend of Dr. Apfelbeck, who was joining our agreement regarding the development of a light weight storage battery and the development of activation processes for catalyzers, and was represented in the contract by the Berlin-Suhler-Waffen-u. Fahrzeugwerke, Suhl, Thuringia. I became head of a private research laboratory connected to the Suhler Waffenwerke (supervising about 6 assistants, income 500 Reichsmark).

After having entered Germany, my Czechoslovakian passport was confiscated by the Gestapo, to make it difficult for me to leave Germany for other countries. I got a Hansen passport by which I became a stateless (and suspected) person.

During this period (1937 - 1939), I was also in the position to study shock-wave-controlled arc plasma systems and to improve the conversion rate, but was not successful in testing shock-wave-controlled plasma zones by plasma-collision-induced nuclear reactions.

In January, 1939, Staatsrat Eberhardt died in Prague, before we could arrange for a new industrial partner, the outbreak of the war broke up this project (until 1945).

DECLASSIFIED
Authority: 12958

APR 26 1999



Still in 1939, I joined the staff of the Junkers Flugzeugwerke, (Junkers Flugzeug- und Motorenwerke, A.G., Dessau), under special research order, supervising 1 assistant, salary 700 Reichsmark,
in 1941, under research contract of the Reichsluftfahrtministerium, Forschungsabteilung 101 (German Air Ministry), became head of a research laboratory at Darmstadt, supervising 8 assistants, salary 700 Reichsmark,

research work on the excitation of mechanical resonance oscillations near the critical speed of flight; series of test flights and nose dives mainly with the proto-type Ju-88,

development of methods and analyzers for testing material stress under extreme thermodynamic and mechanical conditions, based on the excitation of photoelectrically analyzed mechanical resonance vibrations by means of sound and ultra-sound,

(note: this method might be of great interest now in testing materials under hypersonic flight conditions),

analysis of structural damage by micro-vibrations and by corrosion, (note: this method might be of great interest now in testing materials under extreme radiation corrosion),

studies on vibration problems near the sound barrier and in the supersonic region, development of wind-tunnel analyzers, analysis of structural stability of intensively heated up and extremely fast spinning jet turbine blades, development of jet analyzers, s.s.o.,

in research contact with Prof. Busemann and Prof. Dittgen, both research directors at the Luftfahrtforschungsanstalt Hermann Göring, near Braunschweig, Germany,

in the fall of 1941, Prof. Busemann was inviting me to transfer my research laboratory to the Luftfahrtforschungsanstalt, to work with him on rocket and supersonic projects,

by intervention of the Gestapo, I had to stop research work on top secret projects: Prof. Busemann was forced to revoke his offer,

(during this period, I have been travelling quite a lot, visiting various aircraft factories and research institutes in Germany, to obtain data for my work; the Gestapo became suspicious and I think it was in August or September, 1942, when I was arrested for being a British spy; although I was able to clarify the matter, the Gestapo kept on watching me closely),

I went to Berlin to ask the authorities for explanations; they apologized and were offering me a new job at the Deutsche Versuchsanstalt für Luftfahrt, Berlin-Adlershof, which I refused to accept,

when in Berlin in 1943, I contacted Staatsrat Prof. A. Esen, then in charge of the German Nuclear Research Program, asking for a research job in this field, (I became acquainted with Prof. Esen in 1939, when he was visiting my research laboratory at the Junker Waffenerie),

since I was not much interested in joining the program, Prof. Esen, in 1944, I at least accepted a contract with the Laboratorium Fern von Ardenne, Berlin-Idchenfelde-Str.

DECLASSIFIED
EXEMPT FROM GDS
N.I. 100-100

APR 26 1999

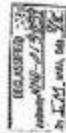

sort of 'personality clash' developed with the baron (he is now in Russia) and then I had to direct experimentation with a Van de Graaff generator under direct order of Army Ordnance, a few weeks later I was asked to resign (it was the Gestapo again - and the personality clash);

similar events happened when I took over a nuclear research job with the Forschungsinstitut of the AEG (Allgemeine Elektrizitäts-Gesellschaft, Berlin) three months later I was kindly asked to resign (intervention of the Gestapo again);

so, I at least accepted a research position at the Deutsche Versuchsanstalt fuer Luftfahrt, Berlin-Adlershof, developing subsonic wind-tunnel turbulence analyzers, based on carrier-frequency-controlled condenser-microphones, (supervising 2 assistants, salary about 700 Reichsmark);

after the clash with the Gestapo in the fall of 1942, I was successful in improving the detectability of shock-wave-induced nuclear reactions, by developing nuclear reaction schemes, based on the chain-reacting consumption of the lithium and beryllium isotopes (the same reaction chains, forming the basis of the hydrogen bomb mechanism);

the basic concept was to start a self-reproducing, shock-wave-ignited reaction chain by jetting lithium into a powerful non-Maxwellian, neutron-producing deuteron high-pressure plasma;

although intending to use self-reproducing nuclear reaction chains as a means for testing non-equilibrium thermodynamics in shock-wave-controlled plasma zones, I, at that time, was fully aware of the fact, that such an experiment would be equivalent with sort of exponential fusion experiment (i.e. the development of a controllable thermonuclear reactor system);

in discussions with the Chief of the Research Department of Army Ordnance, Col. Geist, in January, 1943, he showed himself not interested in this matter; since most of the German scientists and military authorities were not believing in the realization of even a chain-reacting nuclear fission process, I was not astonished about his reaction;

but since then, I for myself became intensively interested in the development of controllable fusion reactor systems;

In 1944, sponsored by the Reichsministerium Speer (Armament and Ammunition Ministry) as well as by the Reichsforschungsrat (Research Council), I signed a contract with the AEG (Allgemeine Elektrizitäts-Gesellschaft), Berlin, dealing with the production of activated catalysts and light weight storage batteries;

I was acting as a consultant with a guaranteed minimum of royalties of 1 million Reichsmark plus 40,000 Reichsmark after successful demonstration of the basic facts, (supervising about 12 assistants, income about 100,000 Reichsmark);

in research contact (and acting as a consultant) with Prof. F. Martin, then chairman of the Anorganische Aktiengesellschaft, Kuelthaus-Ruhr, Germany,

APR 26 1999



besides of the experimental program fixed by the AEC contract, I was carrying out interesting arc plasma experiments privately, using the large test installations available at the AEC transformer plant at Reims-Charsucourt.

When the war was over I was asking for cancellation of this contract, to leave Germany for the U.S. (but could not get a visa).

In 1946, visiting France, having preliminary discussions with the Director general of the French Petroleum Institute, Prof. Léon Jacquet, in 1947, visiting England and Holland, having discussions with scientists and industrialists.

In London, I quite incidentally became acquainted with the chief designer of the former Focke-Wulf Flugzeugwerke, Bremen, Prof. Kurt Tank, who showed himself particularly interested in the development of nuclear powered propulsion systems for aircraft, (in the fall of 1947, Prof. Tank went to Argentina).

In December, 1947, I signed a contract with the French Petroleum Institute, (2 Rue de Lubecq, Paris XVI, France), dealing with research on activated catalysis on a consultant basis, (25 per cent royalties), salary in December, 1947: 50,000 francs,

in August, 1948: 50,000 francs,

an experimental program was progressing at the Ecole Polytechnique, and I became head of this laboratory,

unfortunately, this research contract, limited in time, was by no means a basis for a new position; therefore, despite of all the excellent scientific resonance which I had always found in the circles of my French colleagues, I had to look out for another job in time,

having been invited to do nuclear research in France, I refused to accept because of Prof. Joliot-Curie (then president of the French AEC) being a notorious communist,

In May, 1948, I was invited, privately by Prof. Tank, and half-officially by the Argentine government, to join Tank in Argentina,

In August, 1948, after fulfilling my contract, I went to Argentina, quite unaware of the political situation I would find there,

owing to an arrangement with the French Petroleum Institute, to continue research work in Paris for several months in 1949, I left France for Argentina without signing an Argentine contract,

at the same time, the U.S. Navy became interested in the development of a light weight storage battery; unfortunately, I was not in the position then to transfer myself to the U.S. because I could not get a visa again in time,

when I went to Argentina, I stopped working on battery projects in favor of intending to take up work on nuclear reactor systems, especially on controllable fusion reactor systems.

DECLASSIFIED

Authority: E.O. 12958

APR 26 1999

Chief, Declass Br
Dr. & Rec. Div, WHS



one week after my arrival in Argentina, Prof. Feron had arranged for an audience with Peron.

Peron showed himself particularly interested in the development of nuclear power stations, but in 1948, there was no uranium available in Argentina, and no research facilities,

but there was a certain probability that the chain-reacting scheme, developed in the fall of 1948, ignited by a shock-wave-controlled arc plasma system might turn out to become the basis for a controllable fusion reactor system.

In October or November, 1948, I signed a five-year research contract with the Argentine Air Ministry, dealing with research on nuclear reactor systems, and became head of a research laboratory, located in the Instituto Aerotecnico, Cordoba, (supervising about about 5 assistants, salary 8,000 Pesos),

strange as it is, I never got a copy of this contract in all the years to come.

by January, 1949, my salary was 10,000 Pesos, (supervising between 400 and 500 employees)
by July, 1951, 20,000 Pesos,

In June, 1948, the reactor project at Buena Vista Island was starting from scratch; during this period of construction, data were collected by means of various electronic simulator systems.

on February 18, 1951, an exponential reactor system was ready for test. In the first test, the injection of lithium into a shock-wave-controlled proton hydrogen plasma, for a short interval, produced series of primary and secondary reactions, the helium-3 helium-3 reaction giving proof for the existence of self-reproducing reaction chains.

In a second test, by jetting lithium into a shock-wave-controlled deuterium plasma, a rapidly developing avalanche of neutron-reproducing reaction chains was monitored.

In both tests, the self-reproducing reaction chains were analyzed by means of excitation-energy-discriminating, ultra-violet-sensitive proportional counter tubes (having been especially developed for this purpose).

against my strict advice, Peron announced these results with a great display of propaganda; from this time on I found myself mixed up with political affairs.

still in 1951, Peron offered me the position of a National Director of Atomic Energy; I refused to accept this position to escape political interference with my scientific work. (in all the years before, I never was interested in my 'title of position' but was anxiously keeping myself out of regular administrative obligations to be free for research work.)

still in 1951, under the attack by the foreign press, I was obliged to publish data in order to protect U.S. secrecy in the development of the fusion bomb, (but was discussing the chain-reacting scheme in the hydrogen bomb with friends in the U.S. Embassy in Buenos Aires in February, 1950).

DECLASSIFIED
Authority: 105-1.13
Date: 10/13/99

Chief, Declass Br
Dir & Rec. Div. W-4S



On October 26, 1951, in a third exponential test, it has been proven that the avalanche of neutron-reproducing reaction chains, resulting from the injection of lithium into a shock-wave-controlled, neutron-producing deuterium plasma, can be kept on a high level of reproduction factor by injecting boron.

In a press conference in December, 1951, I predicted in a camouflaged way what we call now thermonuclear.

In July, 1951, I published an article in the United Nations World Magazine, New York, ('Argentina has no Atom Bomb'), mentioning for the first time the underlying chain-reacting scheme of the exponential fusion experiments.

In the fall of 1951, the analysis of the exponential experiments revealed the existence of field-interaction-induced particle acceleration which led to a completely new concept of fusion reactor systems; a relatively large research program was set up to obtain more data.

(When Project Humul was born in 1949, Peron demanded firmly in the presence of his ministers that I should not work out secret reports but keep all the data under strict secrecy; after having arrived at the new concept for fusion reactor systems, I was trying to improve secrecy.

When I was expelled from the reactor project in November, 1952, the authorities seized Humul Island, got all the installations but not the vital analyses - and no data.)

A large-scale reactor system was under construction but has never been completed; sabotage was increasing at Humul Island.

In order to shift the reactor project from the political and propaganda level to a more reasonable and profitable commercial level, in December, 1951, I advised Peron to accelerate reactor development by linking the Argentine project with a highly industrialized country like the U.S.; much to my surprise, he showed himself interested in such a proposition and authorized me to arrange for preliminary industrial discussions.

A few months later, in March, 1952, the political situation in Argentina was obviously beginning to change.

On September 2, 1952, a commission of deputies and a group of Argentine nuclear experts (7) arrived at Humul Island; the only purpose of this commission (headed by the Minister for Technical Affairs, Dr. Raoul Mendiz) was to paralyze the reactor project; facts did not matter at all and were mostly misunderstood; the 'findings' of this commission were pre-set in Buenos Aires, weeks before arriving at Humul Island.

In November, 1952, I suddenly found myself expelled from the project and had to stop work on nuclear matters immediately.

By 'presidential' order I was forced to leave San Carlos de Bariloche for Monte Grande, near Buenos Aires.

There, although not being a prisoner, I was ~~detained~~ ^{degraded} during this period of exile - and it still has Authority ~~to~~ ^{to} work - I could not get another job in Argentina because most of the Argentine and foreign firms in Argentina were meaningfully afraid of government reprisals.

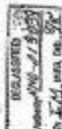

there were similar reactions when I was trying to get visas in order to contact scientific and industrial circles in other countries,
in September, 1954, my name was mentioned in the Chamber of Deputies during a debate on the reactor project; some deputies were quarrelling about possible scientific errors and negative experimental results; to defend my scientific reputation and following a suggestion of my lawyer, I was addressing telegrams to the President of the Chamber, (and to Peron himself) protesting against unjust accusations in public and demanding public hearings;

in the course of a press conference (which took place in the office of my lawyer) I was declaring that as a scientist I should not like to become mixed up with political affairs again; in case the project being a failure, discussions in public should not be hampered by secrecy; this press conference was ignored by all the newspapers in Argentina, but not by the foreign press, such to my surprise, I had to serve a sentence of five days detention in the congress building, ordered by the Chamber of Deputies for violation of its privileges; there were no public hearings and no hearings at all,

(note: the show has been set up to prepare for all negotiations; for the first time in March, 1951, my reputation as a scientist has been unscrupulously sacrificed to produce Peron's nuclear energy myth; now, my reputation has been unscrupulously sacrificed again, this time to destroy Peron's nuclear energy myth in public),

when it had turned out to be absolutely impossible to arrive at a fair settlement in this matter, I was sending back to Peron the honoris causa degree of the University of Buenos Aires and the 'loyalty' Peronista medal (which has been put on me in March, 1951), thus protesting against unfair treatment as a scientist - and risking to be jailed for having offended the president,

quite contrary to what I had expected, the exit of Peron has not changed my own position,

the Lonardi government detained me in the Headquarters of the Federal Police for 20 days and in the National Penitentiary for 5 days for having been a favorite of Peron; at the same time, the press was starting a smear attack again, picturing me as a typical Peron supporter and saying not a word about my exile and constant opposition against peronism and dictatorship in all the years before,

some of the Argentine scientists were displaying an incredible unfairness when I was interrogated; three years ago, the same scientists were helping Peron to paralyse the reactor project by means of faked reports (the 'findings' of the commission in September, 1952; whenever I was asking for publication of these peculiar reports, there was silence and - secrecy),

finally, my lawyer was informed by the National Investigation Commission that the official investigations in the 'Richter case' were closed on December 31, 1955,

but I still was not allowed to leave the country. **DECLASSIFIED Authority E.O. 12958**
Not having a job, (still in 1954, I had to sell my car and household equipment to prevent my family and myself from starving.,

APR 26 1999



the substitution of the Leonard government by the Archbishop government explains to some extent the hostile attitude of the Leonard government against the 'Richter case'.

In May, 1955, Judge Dr. Bobet was starting another investigations, when being interrogated again and again, the investigation turned out to become a complete rehabilitation, but there was no rehabilitation, during the last interrogation about six months ago, Dr. Bobet, despite of my loud and repeated protest, even confiscated the original of my doctor diploma, when I was offering a photocopy,

a few months ago, Dr. Bobet, for some political reasons, lost his position as a judge; but I still cannot get a rehabilitation - and no job, but it seems to be a matter of fact that I am now allowed to leave the country,

when entering exile in February, 1955, I immediately was beginning design work on shock-wave-controlled melting furnaces and chemical arc reactor systems,

still in 1955, I was developing an improved ram jet system, based on the shock-wave-controlled conversion of an intermittent ram jet system into a steady state ram jet system,

on the same basis, it was even possible to develop a propulsion system, interchanging continuously between rocket and ram jet phase, thus substituting turbo jet engines by a shock-wave-controlled combustion reactor system,

For the first time, the extraordinary feedback loop between thrust and air-intake - which is an exclusive feature of a ram jet engine - can be fully developed without the disadvantage of a minimum speed of flight,

These studies have derived free injection experiments and the characteristic curves of the penetrability of shock-wave-controlled plasma nozzles,

in the fall of 1955, and in 1954, much work was done for a better understanding of field-interaction-controlled fusion reactor systems; a workable basis for the development of a generalized theory of particle acceleration in highly-turbulent, magnetic-field-controlled fusion reactor systems was found,

during the same period, a nuclear fission plasma-type reactor system was analyzed theoretically,

First of all, there was the principle fission plasma experiment, controlled by excess reactivity, temperature coefficient, plasma turbulence, and magnetic-field-controlled plasma deformation,

improvement of the control of a fission plasma-type reactor system by critical-size (i.e. critical compression) - controlled plasma pulsation,

pulsation control was improved by the magnetic-field-induced feedback loop between shock-wave-induced plasma turbulence and chance-induced promotion of shock-wave-generating plasma explosions, the shock-wave-generating plasma explosions initiated by the pulsation-controlled facility of the chain-reacting fission plasma itself,

DECLASSIFIED
Authority: E.O. 12958
APR 26 1999



From these theoretical studies derives, that such a shock-wave-controlled pulsation-controlled fission (or fusion) plasma system must be an enormously powerful source of shock-wave-induced ultra-sound, (converting nuclear energy directly into ultra-sound energy),

theoretically, a chain-reacting controllable plasma reactor system (fission or fusion type) will be the only one which can produce nuclear power in the range of millions of kilowatts, when based on the controlled pulsation of supercritical chain-reacting zones; therefore, the optimal output of nuclear-power-induced ultra-sound will be determined and limited by the reactor structure damping effects of the ultra-sound itself,

still in 1944, I have been using the coupling between plasma jets and a magnetic field as a means for analyzing non-Maxwellian plasma conditions; experimental research on a plasma-controlled, energy-converting system (converting nuclear energy directly into electrical energy by the induction effect) has been carried out on a preliminary non-nuclear basis in 1951 and 1952, (deriving from the analysis of plasma induction spectra),

in 1954, a push-pull plasma reactor system has been analyzed theoretically, based on two interconnected reactor vessels which become plasma-critical alternately,

only one vessel becomes critical at a time; when it goes plasma-critical, a plasma jet is firing through a magnetic field, producing electrical energy by the induction effect,

In the fall of 1951, when analyzing the induction spectrum of an extremely turbulent, shock-wave-superimposed plasma of ordinary proton hydrogen, a specific class of signals revealed the existence of sort of 'decaying structures', not resulting from eventual electron capture by protons, forming decaying neutrons,

another class of signals, characterized by extremely large amplitudes and very small pulse width was even indicating the existence of a certain exchange mechanism of energy, the source of the energy being still a mystery; sort of extremely irregular fluctuation spectrum was developing at the very moment of optimal plasma compression,

during the past four years of exile, much theoretical work has been done to clarify this matter; it has been found, at least, that an explanation can be given for the large-amplitude 'exchange signals', when we assume, that highly compressed electron gas becomes a detector for energy exchange with what we call zero point energy,

zero point energy derives from the exclusion principle,

the exclusion principle derives from empirical data,

in a shock-wave-superimposed, turbulence-feed-back process, as some exists a high probability for cell-like super-pressure structures,

zero point energy in balance with the mass energy of the electron gas represents an enormously high energy capacity for exchange processes.

DECLASSIFIED
APR 26 1999
AFR 100-16



about 10^{10} eV per unit volume,

on the basis of exchange coupling, it seems to be possible to 'extract' a compression-proportional amount of zero point energy by means of a magnetic-field-controlled exchange fluctuation between the compressed electron gas and sort of cell structure in space (dimensions about 10^{-12} cm), representing the source of what we call zero point energy.

It seems even possible that the large-amplitude fluctuation signals derive from a mechanism of energy-conversion unknown to us yet which becomes detectable only in highly compressed electron gas.

(It would be of interest to repeat these experiments not with a proton hydrogen plasma - proton spin and electron spin identical - but with a helium-4 plasma, the spin discrepancy supporting energy extraction.)

It would also be worthwhile to search for exchange signals in high-power pulsating fission plasma systems.

In case, all these interpretations are fully correct, plasma implosion analysis might turn out to become an approach to a completely new source of energy, probably superior to nuclear energy.

The present status of this matter can best be compared with the situation, when nuclear fission was discovered, but when the development of a chain-reacting fission reactor system was still depending on the realization of controllable neutron reproduction.

(The compression-induced 'decay signals' can be explained as resulting from wave-mechanical coupling of groups of electrons, the repulsive forces between the electrons becoming neutralized gradually by wave-mechanical coupling with increasing compression.)

First, there was the discovery of the shock-wave-generating process in 1858, the discovery of a feed-back loop between shock-wave-induced plasma turbulence and plasma-turbulence-induced production of shock-wave-generating plasma explosions.

The concept of testing shock-wave conditions by means of plasma-collision-induced nuclear reactions.

The development of nuclear reaction schemes, based on the chain-reacting consumption of the lithium and boron isotopes in 1942.

The concept of a controllable fusion reactor system, ignited by a shock-wave-controlled deuterium high-pressure plasma.

Then came the first series of exponential fusion experiments in February, 1951, and the second series of exponential fusion experiments in October, 1951, giving proof for the existence of self-reproducing reaction chains.

From these experiments derived the discovery of field-interaction-accelerated particles, initiating a completely new class of reactor systems, and the discovery of two specific classes of 'decaying type', deriving from wave-mechanical coupling of electron groups, and the 'large-amplitude-type', deriving from a possible exchange

APR 26 1999

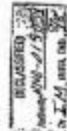

process with a new source of energy, probably the zero point energy,

From the development of super-plasma conditions derives fluctuating plasma explosion as a concept for fusion reactor systems, and as a probable approach to a new source of energy (in any case, as a method for exploring space structure physics),

From the development of a shock-wave-controlled arc melting furnace probably derive series of new materials of construction for rocket and jet engines, and for nuclear propulsion systems, under hypersonic flight conditions,

From the analysis of the penetrability of shock-wave-controlled plasma zones derives the concept for an improved ram jet propulsion system, which will allow to take full advantage of the feed-back loop existing between thrust and air-intake,

From the theoretical analysis of a pulsating fusion plasma system derives the conception of a nuclear-energy into ultra-sound converting reactor system, the conception of a nuclear-energy into electrical energy converting reactor system, and the conception of a nuclear-energy into radiofrequency energy converting reactor system,

During the past four years of exile, much theoretical work has been done in space-time physics, and in unified field theory (having been interested in possible experimental approaches).

DECLASSIFIED
Authority EC 12958

APR 26 1999

Chief, Declass Br
Dir & Rec. Div WHS 448

2. Colonel Nestor's Memorandum Concerning Dr. Richter



CONFIDENTIAL

THE FOREIGN SERVICE
OF THE
UNITED STATES OF AMERICA

DECLASSIFIED
Authority: 25 CFR 17.104
Date: 11/11/2009

119-880

Office of the Air Attache
United States Embassy
Buenos Aires, Argentina
1 April 1957

SUBJECT: (Unclassified) Status of Dr. Ronald W. Richter

TO: Directorate of Intelligence
Headquarters, USAF
ATTN: Air Attache Office
Washington 25, D. C.

1. Reference letter 67-880 this office, dated 20 February 1957, forwarded to Joint Intelligence Objectives Agency, JCS, Room 2D-876, Pentagon, Dr. Richter advises this office that due to financial reasons and the political situation in Argentina he cannot remain in his present status much longer. Dr. Richter has been given encouraging information by visiting atomic scientists in Argentina and also by the U.S. Embassy here but with no employment or financial aid.

2. If the Air Force has any interest whatsoever in Dr. Richter, it is requested that this office be advised by wire of what interest, offer of employment or financial aid which can be given. For your information here are two recent messages which Dr. Richter requests be transmitted to the USAF:

"OFFERING DEVELOPMENT OF MOST POWERFUL LARGE SCALE SOURCE OF ULTRA SOUND BASED ON CHAIN REACTING EXTREMELY TURBULENT NUCLEAR FISSION PLASMA SYSTEM CONVERTING NUCLEAR ENERGY DIRECTLY INTO ULTRA SOUND STOP IMPROVING RANGE OF ULTRA SOUND BASED TORPEDO AND SUBMARINE DETECTING DEVICES STOP DEVELOPMENT OF ULTRA SOUND IMAGE CONVERTING DEVICES STOP DEVELOPMENT OF LONG RANGE GUIDANCE SYSTEMS FOR NUCLEAR ENERGY PROPELLED TORPEDOS AND SUBMARINES STOP LARGE SCALE SOURCE OF ULTRA SOUND WILL PROVIDE PERFECT UNDERSEA NAVIGATION FOR HIGH VELOCITY SYSTEMS AND WILL PROTECT AREAS FROM BEING ATTACKED BY MANNED SUBMARINES STOP"

"OFFERING DEVELOPMENT OF SERIES OF NEW MATERIALS OF CONSTRUCTION FOR ROCKET AND JET ENGINES, FOR NUCLEAR PROPULSION SYSTEMS AND POWER STATION REACTORS, AND FOR AIRPLANE AND GUIDED MISSILE STRUCTURES UNDER HIPERSONIC FLIGHT CONDITIONS STOP MATERIAL PROCESSING ACCOMPLISHED IN SHOCK WAVE CONTROLLED AND MELTING FURNACE KNOCKING DOWN BARRIERS OF THERMAL SOLUBILITY BY MEANS OF ULTRA SOUND INJECTED ALLOWING STOP FOR THE FIRST TIME UNLIMITED AMOUNTS OF ULTRA SOUND CAN BE APPLIED BY GENERATING ULTRA SOUND WITHIN THE ARC PLASMA ZONE ITSELF STOP ULTRA SOUND INDUCED PROCESSING WILL REDUCE PRODUCTION COSTS AND IMPROVE QUALITY OF STEEL STOP SHOCK WAVE FURNACE ALREADY FULLY DEVELOPED AND TESTED STOP FURTHER RESEARCH NECESSARY ON THE CHARACTERISTICS OF ULTRA SOUND PROCESSED MATERIALS STOP"

CONFIDENTIAL

824

CONFIDENTIAL

DECLASSIFIED
AUTHORITY: 25X
DATE: 11/11/2011

Oliva, Buenos Aires, Argentina, 119-280, 1 April 57, Subj: Status of
Dr. Ronald W. Richter

3. Dr. Richter will contact this office on 14 April to determine
the interest of the USAF or any other government agency in his services.

ALBERT F. FAHY, JR.
Colonel, USAF
Air Attache



2

CONFIDENTIAL

824