

CATALOGED BY DDC
AS ID No. 408769

63-4-2



Technical Report 10-TR
TESTS AND EVALUATION OF AN
EARTH CURVATURE CORRECTION DEVICE
Task 4A623501D85301
(Formerly Task 8T35-14-001-01)
5 February 1963

408 769

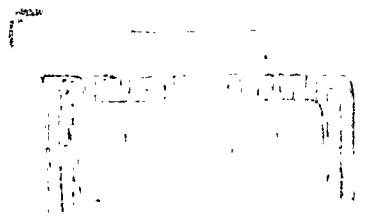

FORT BELVOIR VA

U. S. ARMY ENGINEER
GEODESY, INTELLIGENCE AND MAPPING RESEARCH AND DEVELOPMENT AGENCY
FORT BELVOIR, VIRGINIA

Technical Report 10-TR
TESTS AND EVALUATION OF AN
EARTH CURVATURE CORRECTION DEVICE

Task 4A623501D85301
(Formerly Task 8T35-14-001-01)

5 February 1963

Distributed by
The Director
U. S. Army Engineer
Geodesy, Intelligence and Mapping Research and Development Agency

Prepared by
I. R. Jarrett
Mechanics and Optics Branch
Photogrammetry Division
U. S. Army Engineer
Geodesy, Intelligence and Mapping Research and Development Agency
Fort Belvoir, Virginia

THE VIEWS CONTAINED HEREIN REPRESENT ONLY THE VIEWS OF THE
PREPARING AGENCY AND HAVE NOT BEEN APPROVED BY THE DEPARTMENT OF
THE ARMY.

PREFACE

The authority for the tests and evaluation of this Earth Curvature Correction Device is contained in Task 4A623501D85301 (formerly 8T35-14-001-01), "Engineering Studies and Investigations, Global Mapping and Geodesy (U)." A copy of the task card is included as an appendix to this report.

Work on this project was accomplished by I. R. Jarrett, Q. C. DeAngelis, W. E. Boge, and F. R. Norvelle, under the supervision of J. W. Halbrosk, Chief of the Mechanics and Optics Branch. All work in these tests and evaluation was carried out under the direction of Randall D. Esten, Chief of the Photogrammetry Division.

CONTENTS

<u>Section</u>	<u>Title</u>	<u>Page</u>
	PREFACE	iii
	SUMMARY	vii
I	INTRODUCTION	
	1. Subject	1
	2. Background	1
II	INVESTIGATION	
	3. Description	1
	4. Test Procedure	5
	5. Test Results	6
III	DISCUSSION	
	6. Examination of Test Results	11
	7. Evaluation of the Device	13
IV	CONCLUSIONS	
	8. Conclusions	14
	APPENDIX	15

SUMMARY

This report covers the tests and evaluation of an internally developed Earth Curvature Correction Device for use with an anaglyphic projection-type stereoplotter in military mapping. Tests of the device were carried out on the High Precision Military Stereoplotter.

The report presents evidence of the state of calibration of the plotter, the flatness of a stereoscopic grid model, and the accuracy of the curved surface developed by the correction device when compared to computed values. The corrections were measured by elevation readings in a grid model with the device in operation and by dial gauge readings referenced to the plotter table.

The report concludes that:

a. The basic principles incorporated in the device to compensate errors in a model due to earth curvature proved to be sound and effective in operation on an anaglyphic projection plotter.

b. Refinements in the general design and minor changes in the moving parts of the Earth Curvature Correction Device should result in an attachment to the tracing table which will aid in obtaining accurate vertical height readings and greatly facilitate the contouring operation for topographic mapping.

TESTS AND EVALUATION OF AN
EARTH CURVATURE CORRECTION DEVICE

I. INTRODUCTION

1. Subject. This report covers the engineering tests and evaluation of an Earth Curvature Correction Device to determine the practicability of the design for use with the High Precision Kelsh-Type Stereoplotter.

2. Background. An Earth Curvature Correction Device attachment for the tracing table was developed in connection with the development of the High Precision Military Stereoplotter. The device employed a single ball-type cam actuated by one guide rod to impart corrective motion to the platen. Tests, however, proved the design to be basically unsound and inadequate both mechanically and in ease of operation.¹

Because of the potential advantages of reduction in time and improvement in accuracy envisioned by application of such a device, the Mechanics and Optics Branch designed a new earth curvature corrector and a test model was fabricated in the U. S. Army Engineer Research and Development Laboratories (USAERDL) shops.

II. INVESTIGATION

3. Description. The device tested was designed to be attached to the platen holder arm of the tracing table and to receive its motion from both light guide rods of a projection-type stereoplotter.

a. Theory. The computation of dropoff due to earth curvature is based on the assumption that the earth is spherical. Also, a portion of the assumed sphere can be closely approximated by a section of a paraboloid represented by $\Delta z = 0.67 m^2$, where Δz = correction in feet on the ground and m = distance from the center in miles. Correction cams could be computed by a more exact (circle) formula if necessary. Different cams are needed for different scales.

The correction for a stereomodel could be provided by a single asymmetrical ball-type cam, but it would be almost impossible to machine. Therefore, in the design of this compensation device,

1. USAERDL Technical Report 1627-TR, Stereoplotter, Topographic, Projection-Type, High Precision, dated 29 April 1960.

two cams which allow flat construction are used, an X-cam moving in the X-Z plane and a Y-cam moving in the Y-Z plane. The combined motion of the two cams is applied by means of a lever arm operating on a pivot attached to the platen which moves vertically a short distance (Fig. 1). Each of these cams may be interchangeable with cams designed to correct the effect of earth curvature for other flight heights.

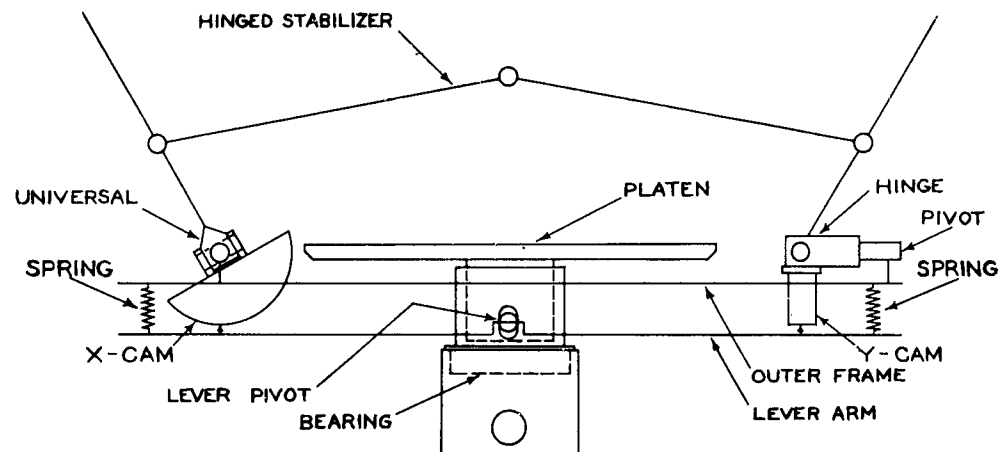

Fig. 1. Schematic diagram of the earth curvature correction device.

The two flat cams for use in tests of the device were designed to provide correction for a flight height of 60,000 feet. Figure 2 presents a diagram of departures from flat caused by curvature of the earth at distances on the ground represented by the grid used in these tests.

This device, although designed to compensate for the effect of earth curvature, could be used to correct other systematic elevation errors present in a stereomodel.

b. Description of Device. The test model developed (Figs. 1 and 3) uses a cam moving only in the X-Z plane which is actuated by the left guide rod and a cam moving only in the Y-Z plane which is actuated by the right guide rod. The two correction increments thus obtained are applied to the moveable platen by the attached lever arm which is spring loaded and in point contact with the two interchangeable cams. The structurally rigid outer frame lever arm and the mechanism are allowed to pivot horizontally by a bearing

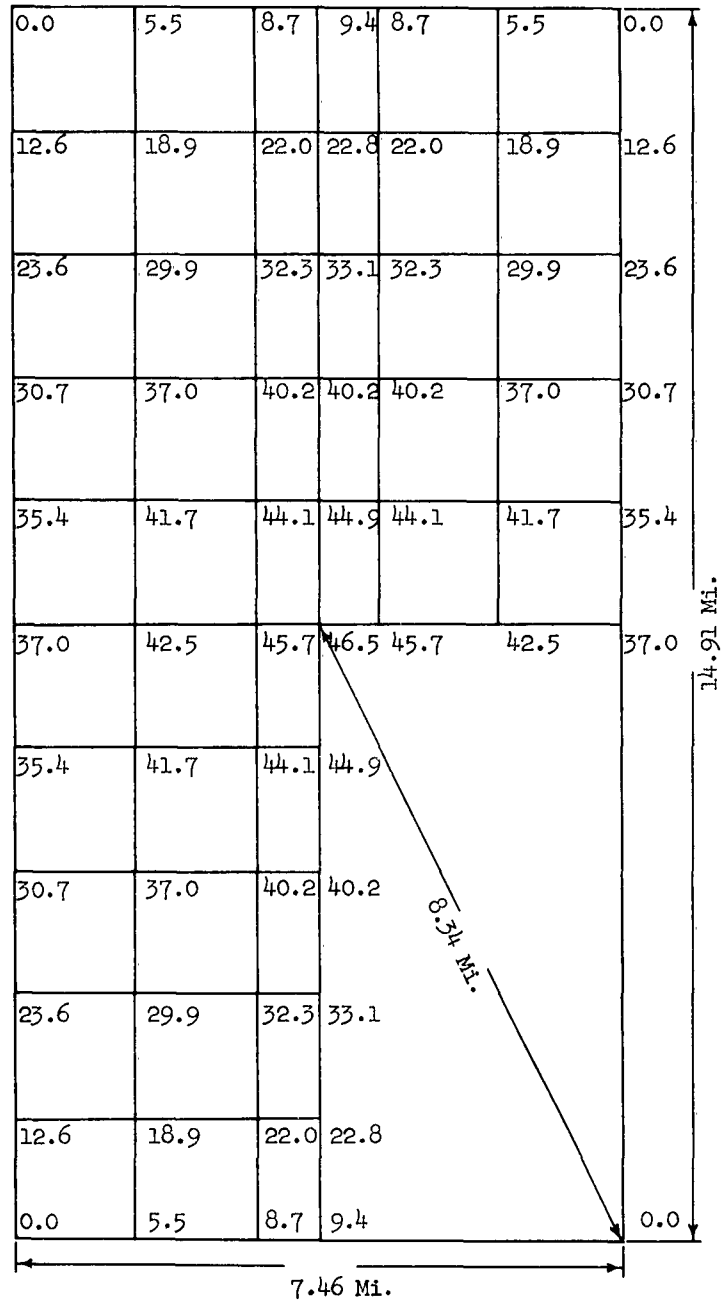

Fig. 2. Computed earth curvature correction values in feet at distances on the ground in miles, as shown. Model B/H = 0.65, flight height equivalent to 60,000 feet.

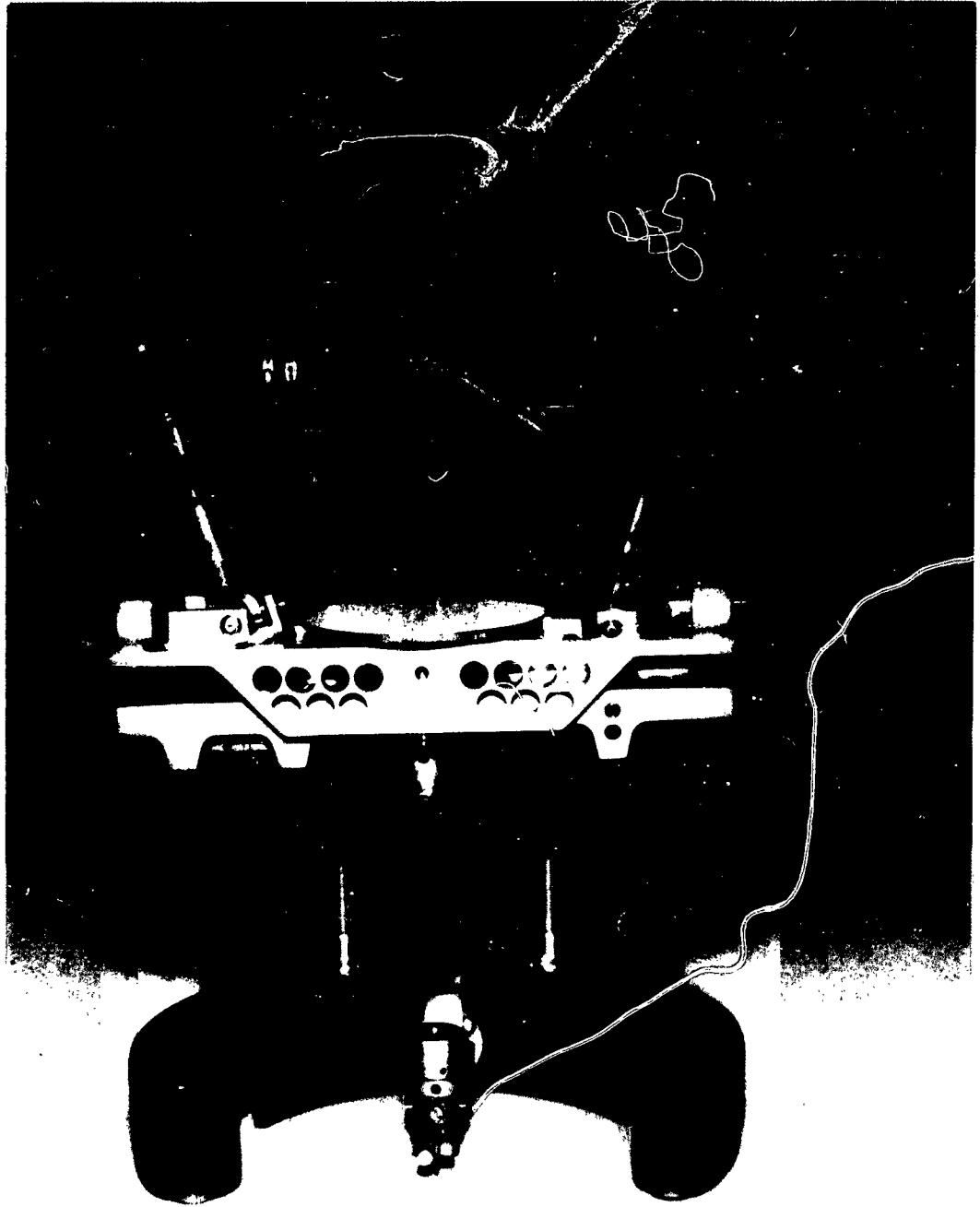

Fig. 3. Earth curvature correction device.

J9055

within a connector collar whenever it is necessary to rotate the tracing table. The hinged stabilizer and springs maintain alignment of the device parallel to the flightline of the model which is required for accurate positioning of the cams.

4. Test Procedure. Two methods of testing the compensation device were used to obtain earth curvature correction data from positions within a stereoscopic grid model. One method required the stereoscopic observation of the grid intersections of the model with the device in operation. The other method consisted of taking dial gauge measurements of the vertical displacement of the platen effected by the device as the tracing table was moved parallel to the X- and Y-axes. These data were later compared with computed correction values.

a. Preliminary Plotter Tests and Adjustments. The High Precision Plotter was tested and adjusted to minimize the plotter errors. These tests consisted of a plotting table flatness test and a grid model flatness test to check the general calibration of the plotter.

(1) Table Top Flatness Tests and Adjustment. A preliminary grid model test for flatness revealed that the honeycomb aluminum plotting table had a large low area in the middle; consequently, a comprehensive test of the table flatness was performed. A Brown & Sharp, 72-inch straightedge was suspended above the table by supporting it on two 4- by 4- by 3/4-inch wooden members resting on the floor. A dial gauge was attached to a surface indicator block, and clearance readings were taken at numerous locations along the straightedge at four positions on the table top. By adjusting the center support, a correction of 0.005 inch was applied at the center of the table to flatten the surface to a tolerance of ± 0.0015 inch.

(2) Grid Model Flatness Tests. After the table top had been flattened, a stereo-pair of 9- by 9-inch grid plates with 20-millimeter grid spacing was obtained. When the stereo-grid model was formed of 5 grid blocks of forward overlap by 10 grid blocks front to rear, the B/H ratio was 0.65. With the projection distance set for a five-time magnification, three independent sets of data of the 66 grid intersections within the neat model were obtained by two experienced operators.

b. Earth Curvature Corrector Grid Model Tests. The Earth Curvature Correction Device was attached to the platen support arm of the tracing table and connected to the light guide rods. A stereogrid model similar to that described in paragraph 4a(2) was

checked for level at the four corners. Then height determinations were made by lowering the floating dot at each intersection. The readings so obtained were found to be erratic even though they were made by approaching all points in the same direction and by keeping the device aligned to the X-axis. It was discovered that considerable backlash was present in the tracing table and that more consistent readings were obtained when the floating dot was brought up, rather than down, to the intersection. The first set of data was therefore discarded, and thereafter all elevation determinations for the four succeeding tests were made by using the second method of reading the points.

c. Earth Curvature Corrector Dial Gauge Tests. The dial gauge tests consisted of measuring the correction displacement imparted to the platen by each cam operating individually to show the accuracy of each. A dial gauge attached to a stand was used to measure the height changes referenced to the plotting table. Measurements of the platen height were taken at grid intersections as the tracing table was moved along the principal X-axis; thus only the X-cam was in operation. The dial gauge was indexed at the center of the model and to a point located near the reference mark of the platen. This same point on the platen was used at each position to eliminate error caused by a minor sloping of the platen. Similar measurements were made along the major Y-axis with only the Y-cam in operation.

d. Observations. During the course of testing, observations of the performance of the correction device were made. It was noted that backlash or lost motion occurred in some of the moving parts of the mechanism; no serious problems of friction or binding of moving parts were encountered, even for awkward positions of the tracing table; and only small errors in cam position were introduced by a minor twist of the tracing table. The design was generally satisfactory but, of course, could be improved.

5. Test Results. Test data were reduced, compared, and analyzed statistically to determine the accuracy of the Earth Curvature Correction Device. A standard deviation² (σ) was computed where it was believed that valid and sufficient data had been obtained, although the errors were not completely random. For this investigation, the standard deviation is used to indicate the general accuracy of the flat grid model and of the correction surface.

2. The standard deviation for a grid test was computed: $\sigma = \sqrt{\frac{\sum d^2}{n}}$
 where d is the deviation from the mean and n is the number of points.

a. Plotter Test Results. Height errors about a flat plane of reference were computed for each of three tests. The maximum error from the flat plane of reference found in any of the tests was 0.04 millimeter. From the three values, an average error for each point was computed (Fig. 4). The standard deviation calculated from this data was ± 0.016 millimeter.

b. Earth Curvature Corrector Device Test Results. The data for each of the four tests were mathematically levelled to the corner points and direction signs were changed so as to be directly comparable with the computed correction values. Correction values in millimeters were computed for all intersections within the neat model in a manner similar to those in Fig. 2. Data from the four tests were reduced as follows: (1) An average error was obtained for each point and was considered to be the error of that point, (2) a mean of these errors was found, and (3) a standard deviation about the mean was computed as a general indication of the accuracy with which the correction surface was generated. The diagram in Fig. 5 shows the residual error at each point from the four sets of data of the correction surface. The standard deviation for 66 points was slightly under ± 0.02 millimeter.

c. Dial Gauge Test Results. Average values were derived from the Δz displacements measured at positions on the X-axis which were plotted for drafting of a curve to indicate the X correction surface (Fig. 6A). Random errors about the computed curve were slightly larger than ± 0.01 millimeter.

The average Δz displacement values obtained for positions on the Y-axis were plotted, and the resulting curve was drawn (Fig. 6B). These points plotted from the measured values, with the exception of one point, departed systematically from the computed curve, outwards from the center position in the model.

d. Observed Results. Certain minor faults in the design of the device (mentioned briefly in paragraph 4d) that possibly affected the general operation but not the results of these tests are:

(1) The frames of the mechanism were cumbersome, and the design was somewhat impractical for fabrication and assembly. The inaccessibility of parts resulting from the design of the frame and lever arm made adjustment of parts difficult. Lost motion of the follower on the Y-cam resulted from lack of a good fit of these two members which made it necessary to add shims to the frame so as to obtain better repeatability of readings in the tests.

+0.010	+0.003	0.000	+0.003	+0.003	+0.017
+0.027	+0.017	+0.010	+0.013	+0.013	+0.003
+0.027	+0.027	+0.007	+0.023	+0.013	0.000
+0.023	+0.020	+0.007	+0.003	+0.010	+0.007
+0.017	0.000	0.000	-0.007	-0.003	-0.001
+0.003	-0.013	-0.013	-0.010	-0.020	-0.003
0.000	+0.007	-0.003	-0.007	-0.007	-0.010
-0.007	0.000	0.000	-0.010	0.000	-0.007
0.000	-0.003	-0.010	-0.007	0.000	-0.010
-0.013	+0.003	0.000	-0.007	+0.007	-0.013
-0.013	-0.003	+0.007	+0.007	+0.010	-0.003

Fig. 4. Grid model flatness test (20-mm grid, $B/H = 0.65$). Residual departures are in millimeters from a flat grid. Values are averages as determined from three independent sets of data.

0.00	-0.01	+0.02	+0.01	+0.01	+0.01
-0.02	-0.03	-0.03	-0.01	-0.02	+0.01
-0.05	-0.03	-0.04	-0.04	-0.03	-0.02
-0.03	-0.05	-0.03	-0.03	-0.04	-0.01
-0.05	-0.03	-0.01	-0.00	-0.02	+0.00
+0.02	-0.02	+0.01	+0.01	0.00	+0.04
0.00	-0.03	-0.01	+0.00	+0.00	+0.01
-0.03	-0.05	-0.04	-0.04	-0.04	-0.05
-0.02	-0.02	-0.02	-0.01	-0.02	-0.02
-0.03	-0.04	-0.03	-0.03	-0.03	-0.01
-0.02	-0.00	-0.02	-0.02	-0.00	+0.00

Fig. 5. Diagram showing residual error from correction surface of each point from four sets of measurements. Cam corrections were computed at a scale of 1,24,000 at ground distances as shown in Fig. 2. Values are in millimeters.

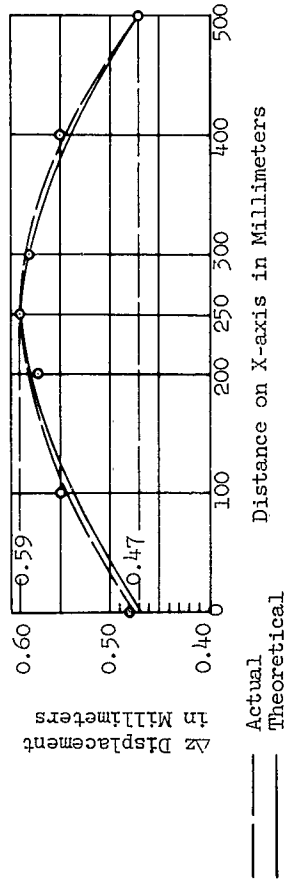

Fig. 6A. Graph showing actual correction from X-cam compared to theoretical.

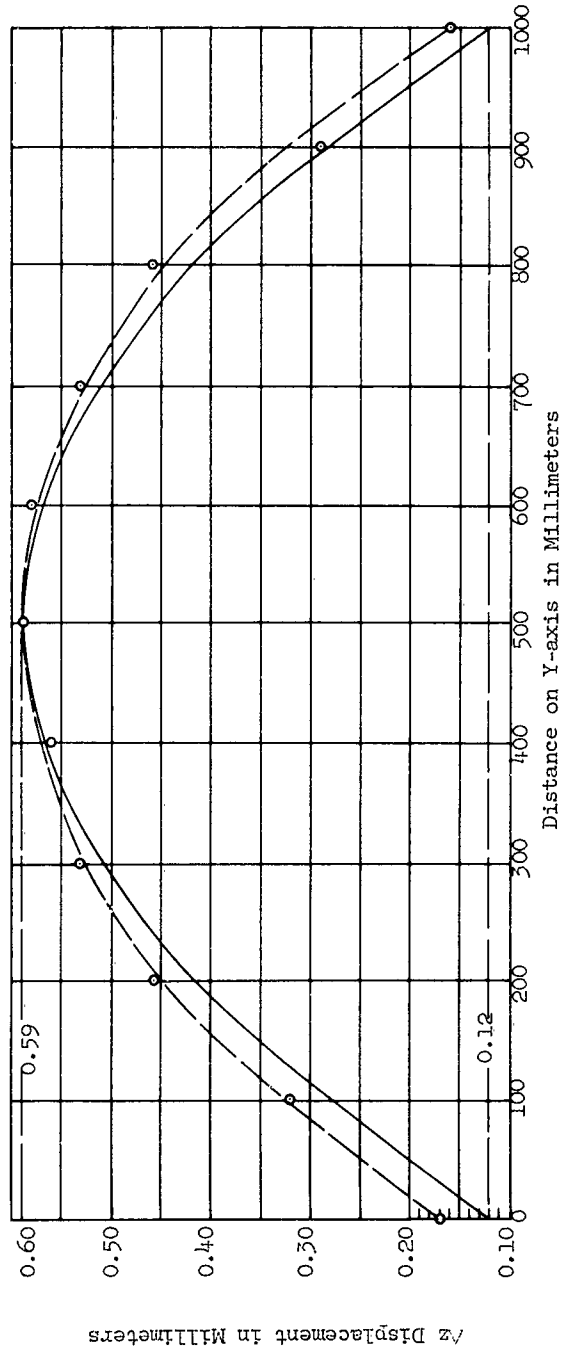

Fig. 6B. Graph showing actual correction from Y-cam compared to theoretical.

(2) The design of the mechanism limited the size of the cams which were not large enough for ease in machining or for convenience in adjusting. The mountings of the cams did not provide good accessibility for replacement or allow adjustment to set the correct operating radii.

(3) The bearing used to allow the device to pivot in respect to the tracing table let too much looseness occur between the mechanism and the connector collar.

(4) The size of the pivots of the hinged stabilizer, although adequate in this application, probably would get too loose in constant use due to the ever changing forces exerted upon them. This looseness could then lead to poor repeatability of the followers on the cams.

III. DISCUSSION

6. Examination of Test Results.

a. Grid Model Reference Datum. The check of the calibration of the High Precision Plotter by a series of height readings of a stereogrid model proved the condition of the plotting instrument to be satisfactory and, in turn, served as an adequate reference datum. The flatness of this datum as read by one operator was substantially verified by readings made by another experienced instrument operator.

The standard deviation of the mean errors for the grid tests of ± 0.016 millimeter is believed to be about the range of the minimum height difference that can be accurately determined by an operator reading a model. The relatively small random errors (not greater than 0.04 mm) may have been caused by backlash in the tracing table, by residual parallax from the orientation solution, or by operator error in the heighting operation.

b. Earth Curvature Corrector Grid Model Tests. The basis of reference as resolved from the grid model flatness tests effectively established the validity of the plotting instrument and the method used in tests for the determination of the accuracy of compensation provided by the device. It is believed that sufficient precautions were taken by the instrument operators in setting the floating dot to the grid intersections to insure representative but accurate height data from the cam-developed correction surface. Also, enough observations were made of this surface to allow a valid comparison to be made with the computed correction surface. Each

height determination for each test was made three times to minimize operator error, and only the average value was recorded.

The small residual departures from a flat grid (Fig. 4) were not considered significant to these tests in the determination of errors of the cam-developed correction surface. It is believed that the standard deviation of ± 0.02 millimeter, which was determined from the four tests of the device, proved the high accuracy of the correction surface obtained. Since the standard deviation from tests without correction was 0.016 millimeter and with correction 0.020 millimeter, it is considered to indicate that error contributed by the correction device was very small.

The occurrence of random errors in the tests, some as large as ± 0.05 millimeter as shown in Fig. 5, must be considered and analyzed even though errors of this size were not frequent. These random errors may have been contributed from several sources such as the device, the plotting instrument, and/or the operator. A different tracing table no doubt would reduce the systematic error such as occurred in test 1 and probably would lower the incidence and size of the random errors. Operator error is dependent mainly, of course, upon the operator's ability to obtain a refined orientation solution of the model and upon his performance of the heighting operation.

c. Dial Gauge Tests. These tests of the X- and Y-cams operating individually did isolate the height measurements for a check of the accuracy of each cam.

A comparison of the curve for the measured values of the X correction cam (Fig. 6A) with the curve for the computed values, indicated the correction surface to be accurate within ± 0.01 millimeter. This indicates that the Δz displacements provided by the X-cam were about correct.

The graph for the Y-cam (Fig. 6B) shows that all the points for the measured values except one fall on a smooth curve. But these Δz displacements were systematically erroneous, which caused the actual correction curve to deviate from that for the computed values. The correction surface from the Y-cam therefore did not conform exactly to the computed shape ($\Delta z = 0.67M^2$), but it would not be difficult to correct (the parabolic shape was empirically estimated to be, $\Delta z = 0.59M^2$). The magnitude of the departures at the ends is larger than the maximum from the stereogrid test; consequently, it is concluded that some errors were slightly compensating. The inaccuracy of the correction surface developed from the Y-cam indicates that either the curvature of the Y-cam was

not exact or the operating radius of the cam was perhaps too small. Each cam could be centered laterally along a chord of the curved correction surface. However, no adjustment was provided in the mounting of the cams by which the length of their operating radii might be changed.

d. Design Improvement. It is believed that most of the deficiencies observed during testing and mentioned in paragraph 5d can be eliminated by the following design changes:

(1) The frames of the mechanism should be designed to provide clearance for larger cams and a larger diameter pivot bearing, easier access of parts, strong but thinner material, and closer tolerances between some of the parts to reduce lost motion.

(2) Size of cams should be increased for greater correctional surface, easier machining, and adjusting. The mounting for the cams should be designed to facilitate adjustment or replacement of cams for different flight heights.

(3) A larger diameter or different type of bearing should be used in the pivot of the mechanism within the connector collar to provide greater overall stability and to reduce the height of the device.

(4) The size of the pivots of the hinged stabilizer should be increased. This sturdier pivot would help hold the device parallel to the flightline, which would consequently aid in minimizing the random heighting errors.

7. Evaluation of the Device. The operation of the Earth Curvature Correction Device proved to be both effective and accurate as was discussed in paragraphs 6b and 6c. However, the errors in the correction surface that occurred from the device may have been caused by errors in the cam, looseness in the mechanism, or changes in lateral movement of the tracing table. The addition of shims (paragraph 5d(1)) between the outer frame and the lever arm on the Y-side helped to maintain the follower in the correct position on the cam for better repeatability of readings. Also, only small errors were introduced by a minor twist of the tracing table (paragraph 4d) which meant that the stabilizer and springs performed their function, keeping the device aligned to the X-axis. Undoubtedly, some errors in the correction surface were contributed by looseness of the platen holder arm on the columns and by looseness of the spindle of the tracing table, which could not be reduced as no adjustments were provided.

IV. CONCLUSIONS

8. Conclusions. It is concluded that:

a. The basic principles incorporated in the device to compensate errors in a model due to earth curvature proved to be sound and effective in operation on an anaglyphic projection plotter.

b. Refinements in the general design and minor changes in the moving parts of the Earth Curvature Correction Device should result in an attachment to the tracing table which will aid in obtaining accurate vertical height readings and greatly facilitate the contouring operation for topographic mapping.

APPENDIX

AUTHORITY

Item 3285
CETC Meeting 328

ADT & E PROJECT CARD		1. TYPE OF REPORT <input checked="" type="checkbox"/> NEW <input type="checkbox"/> FINAL <input type="checkbox"/> REPLACES (No. & Date)		REPORT CONTROL SYMBOL ESCRD-1 (R2)	
2. PROJECT TITLE Engineering Studies and Investigations, Global Mapping and Geodesy (U)		3. SECURITY OF PROJECT U		4. PROJECT NO. 8T35-14-001	
		8T35-14-001-01		6. REPORT DATE 23 Oct 1961	
7. BASIC FIELD OR SUBJECT Mapping, Charting and Geodesy		8. SUB FIELD OR SUBJECT SUB GROUP Global Mapping and Geodesy		9. CATEGORY SO	
10a. COGNIZANT AGENCY Corps of Engineers		11a. CONTRACTOR AND/OR GOVERNMENT LABORATORY US Army Engineer Geodetic Intelligence and Mapping Research and Development Agency Ft. Belvoir, Va.		5. CONTRACT NUMBER	
6. DIRECTING AGENCY R&D, OCE					
7. REQUESTING AGENCY Office, Chief of Engineers					
12. PARTICIPATION BY OTHER MILITARY DEPT'S. AND OTHER GOVT. AGENCIES		14. SUPPORTING PROJECTS SVC		18. EST. COMPLETION DATES DEV. Cont. ENGR TEST. Cont. OPER TEST. N/A OPERATIONAL N/A	
13. COORDINATION ACTIONS W/OTHER MILITARY DEPT'S. & OTHER GOVT. AGENCIES		16. DATE APPROVED 19 January 1962 by GSUSA		19. EST. SUPPORT LEVEL <input checked="" type="checkbox"/> UNDER \$50,000 <input type="checkbox"/> \$50,000 - \$100,000 <input type="checkbox"/> \$100,000 - \$250,000 <input type="checkbox"/> \$250,000 - \$500,000 <input type="checkbox"/> \$500,000 - \$1,000,000 <input type="checkbox"/> OVER \$1,000,000	
		17. PRIORITY 1-B		17. BUDGET CODE 5600	
20. CDOG Para 1731 (A) a		21. SPECIAL CODES			
22. REQUIREMENT AND/OR JUSTIFICATION There is a requirement for conducting studies and investigations in connection with this sub field which cannot be scheduled under other tasks in this area. The principal activities to be performed will pertain to keeping abreast of the state-of-the-art and to providing consultant services to user agencies and higher authority.					
23. a. Brief (1) Objective (a) Conduct necessary investigations to keep abreast of the state-of-the-art and, prior to the establishment of a requirement for the initiation of a task or item, to develop data for the user, at his request, which will determine necessity for, or the feasibility of, specific research and development of equipment, techniques, or materials in the field of Global Mapping and Geodesy.					
DD FORM 613 1 FEB 60		PREVIOUS EDITIONS ARE OBSOLETE.		PAGE 1 OF 3 PAGES	

RDT & E PROJECT CARD CONTINUATION		REPORT DATE	PROJECT NO.
		23 Oct. 1961	8T35-14-001-01
<p>(b) Conduct studies and investigations required for determination of technical data concerning existing systems, equipment, techniques, or materials in support of research and development in the field of Global Mapping and Geodesy.</p> <p>(c) Prepare and submit comments, recommendations and special reports in connection with the above activities as may be appropriate, or as specifically requested by higher authority.</p> <p>(2) Technical Characteristics: Not applicable.</p> <p>b. Approach:</p> <p>(1) The scope of the work within this task will be in accordance with the needs of the developing agency, the user, or as required by higher authority; and will fall into the following categories:</p> <p>(a) State-of-the-Art:</p> <p><u>1</u> Conduct liaison with other government agencies and private firms by providing membership on boards, panels, and industrial committees, for the purpose of keeping abreast of the state-of-the-art in this field.</p> <p><u>2</u> Conduct studies and investigations into natural laws, ways of improving material; and new applications of scientific principles to material, methods, or techniques.</p> <p>(b) Consultant Services:</p> <p><u>1</u> Conduct preliminary studies and investigations as requested by the user, to determine the feasibility or practicability of establishing a qualitative requirement for an item of equipment, technique or system.</p> <p><u>2</u> Coordination with the appropriate agencies on necessary actions concerning the establishing of military and technical characteristics, and other actions leading to the initiation of a specific task, in response to an established</p>			
DD FORM 613c 1 FEB 60		REPLACES DD FORM 613-1, WHICH IS OBSOLETE.	PAGE 2 OF 3 PAGES

Task or 3285/328

RDT & E PROJECT CARD CONTINUATION	REPORT DATE 23 Oct 1961	PROJECT NO. 8T35-14-001-01
<p>requirement for an item of equipment, a technique, or a system.</p> <p><u>3</u> Provision of consultant services to the Engineer School, Army Map Service, USCONARC, Chief of Engineers, Department of the Army, other technical services and government agencies.</p> <p><u>4</u> Review of, and furnishing technical comments, on suggestions and inventions.</p> <p><u>5</u> Provision of technical support for authorized shows, exhibits and demonstrations.</p> <p>(2) No actual research and development of end items will be conducted under this task, and no work will be performed under this task which properly falls within the scope of an existing project or task.</p> <p>c. Tasks: Not applicable.</p> <p>d. Other information: None.</p>		
<p>DD FORM 613c 1 FEB 60</p> <p>REPLACES DD FORM 613-1, WHICH IS OBSOLETE. PAGE 3 OF 3 PAGES</p>		

Category 11 - Mapping and Geodesy

DISTRIBUTION FOR GIMRADA REPORT 10-TR

TITLE Tests and Evaluation of an Earth Curvature Correction Device

DATE OF REPORT 5 Feb 63 TASK 4A623501D85301 CLASSIFICATION U
(formerly 8T35-14-001-01)

<u>ADDRESSEE</u>	<u>REPORT</u>	<u>ABSTRACT</u>
<u>Department of Defense</u>		
Assistant Secretary of Defense ATTN: Technical Library Washington 25, D. C.	1	-
Director Defense Intelligence Agency ATTN: DIAMC Department of Defense Washington 25, D. C.	1	-
<u>Department of the Army</u>		
Assistant Chief of Staff, Intelligence Department of the Army ATTN: Mapping and Geodesy Division Washington 25, D. C.	1	-
Office of Chief of Research and Development Combat Materiel Branch ATTN: Lt Col Gordon G. Schrader Room 3D430, Pentagon Washington, D. C.	1	-
District Engineer U. S. Army Engineer District, Alaska ATTN: NPAGA P. O. Box 7002 Anchorage, Alaska	1	1
Chief of Engineers Department of the Army ATTN: ENGT&ME Washington 25, D. C.	1	-

<u>ADDRESSEE</u>	<u>REPORT</u>	<u>ABSTRACT</u>
<u>Department of the Army (cont'd)</u>		
Chief of Engineers ATTN: Librarian, Technical Library P. O. Box 1715 Baltimore 3, Maryland	1	-
OCE Liaison Officer U. S. Army Combat Developments Experimentation Center Fort Ord, California	1	1
Commanding Officer Army Map Service ATTN: Code 3440 Washington 25, D. C.	1	-
Commanding Officer Army Map Service ATTN: Code 4201 Washington 25, D. C.	1	-
Commanding Officer Army Map Service ATTN: Code 1951 Washington 25, D. C.	1	-
Commanding Officer Army Map Service ATTN: Code 5220 Washington 25, D. C.	1	-
Inter-American Geodetic Survey Liaison Office c/o Army Map Service Washington 25, D. C.	20	-
Commanding Officer U. S. Army Engineer Combat Development Agency Fort Belvoir, Virginia	1	-
Commandant U. S. Army Engineer School ATTN: Director, Department of Topography Fort Belvoir, Virginia	1	-

<u>ADDRESSEE</u>	<u>REPORT</u>	<u>ABSTRACT</u>
<u>Department of the Army (cont'd)</u>		
Commandant U. S. Army Engineer School ATTN: USAES Library Fort Belvoir, Virginia	1	-
Commandant U. S. Army Engineer School ATTN: Chief, Training Literature Division Fort Belvoir, Virginia	1	-
Commandant U. S. Army Engineer School ATTN: Mr. Gribok Fort Belvoir, Virginia	1	-
District Engineer U. S. Army Engineer District ATTN: LML0S-L 420 Locust Street St. Louis 2, Missouri	1	-
District Engineer U. S. Army Engineer District, Lake Survey 630 Federal Building Detroit 26, Michigan	1	-
Commander U. S. Army Mobility Support Center ATTN: SMOMC-E P. O. Box 119 Columbus 16, Ohio	1	-
Commander U. S. Army Mobility Support Center ATTN: SMOMC-F P. O. Box 119 Columbus 16, Ohio	1	-
Commander U. S. Army Mobility Support Center ATTN: SMOMC-S P. O. Box 119 Columbus 16, Ohio	1	-

<u>ADDRESSEE</u>	<u>REPORT</u>	<u>ABSTRACT</u>
<u>Department of the Army (cont'd)</u>		
Commander U. S. Army Mobility Support Center ATTN: SMOMC-ML P. O. Box 119 Columbus 16, Ohio	3	-
Chief U. S. Army Engineer Procurement Office, Chicago ATTN: Chief, Technical Division 226 W. Jackson Boulevard Chicago 6, Illinois	1	-
Commanding Officer U. S. Army Engineer Supply Control Office Corps of Engineers ATTN: SMOSCYK-E P. O. Drawer 58 St. Louis 66, Missouri	6	1
The Engineer Headquarters, USAREUR ATTN: I&M Branch Engineer Division APO 403, New York, New York	1	2
Office Of The Engineer Headquarters, U. S. Army Caribbean ATTN: CARCE Fort Amador, Canal Zone	1	1
Commanding Officer U. S. Army Map Service, Far East ATTN: Chief, O&P Division APO 67, San Francisco, California	3	3
Headquarters U. S. Army Communications Zone, Europe ATTN: Engineer Intelligence and Mapping Section APO 58, New York, New York	2	2

<u>ADDRESSEE</u>	<u>REPORT</u>	<u>ABSTRACT</u>
<u>Department of the Army (cont'd)</u>		
CofELiaison Officer U. S. Army Electronics Research & Development Laboratory ATTN: SIGRA/SL-INE Fort Monmouth, New Jersey	1	-
Commanding Officer U. S. Army Electronics Research & Development Laboratory ATTN: SELRA-SAP Fort Monmouth, New Jersey	1	-
Commanding Officer U. S. Army Polar Research and Development Center ATTN: EPROP Fort Belvoir, Virginia	1	-
Commanding General U. S. Continental Army Command ATTN: MDENG Fort Monroe, Virginia	1	-
President U. S. Army Armor Board ATTN: Chief, Topographic Branch Fort Knox, Kentucky	1	-
President U. S. Army Air Defense Board Fort Bliss 16, Texas	-	1
Redstone Scientific Information Center U. S. Army Missile Command ATTN: Chief, Document Section Redstone Arsenal, Alabama	2	-
Commanding Officer U. S. Army Munitions Command ATTN: No. 0270 - Library Frankford Arsenal Philadelphia 37, Pennsylvania	1	-

<u>ADDRESSEE</u>	<u>REPORT</u>	<u>ABSTRACT</u>
<u>Department of the Army (cont'd)</u>		
Commanding Officer U. S. Army Electronics Research & Development Laboratory ATTN: SELRA/SVD Fort Monmouth, New Jersey	1	-
Commanding Officer U. S. Army Electronics Research & Development Laboratory ATTN: SELRA/SS Fort Monmouth, New Jersey	1	-
Mr. Robert K. Fox Headquarters, U. S. Army Materiel Command R&D Directorate Building T-7 Washington 25, D. C.	-	1
Commanding General U. S. Army Intelligence Center ATTN: ACIH-BD Fort Holabird Baltimore 19, Maryland	1	-
U. S. Army Standardization Group UK 1 P. O. Box 65, USN 100 FPO, New York, New York	1	-
Office of the Senior Standardization Representative U. S. Army Standardization Group, Canada c/o Directorate of Equipment Policy Canadian Army Headquarters Ottawa, Canada	1	-
<u>GIMRADA</u>		
MCLAEB Air Force Liaison Office GIMRADA Wright-Patterson Air Force Base, Ohio	1	-
Director	1	-
Technical Advisor	1	-

<u>ADDRESSEE</u>	<u>REPORT</u>	<u>ABSTRACT</u>
<u>GIMRADA (cont'd)</u>		
Director of Tactical Systems	1	-
Chief, Photogrammetry Division	2	-
Chief, Graphics, Strategic Systems, Sur & Geodesy, Res & Analysis, and Intelligence Division(s) (Circulate)	1	-
Chief, Mechs & Optics Branch	4	-
<u>USAERDL</u>		
Commanding Officer	1	-
Technical Documents Center	2	-
Office of Patents	1	-
British Liaison Officer	5	-
Canadian Liaison Officer	5	-
Technical Reports Office	2	-
Engineering & Technical Service Department(s) (Circulate)	1	-
<u>Department of the Air Force</u>		
Headquarters, U. S. Air Force ATTN: AFCIN-3K Washington 25, D. C.	1	1
Headquarters, U. S. Air Force ATTN: AFORQ-RN Washington 25, D. C.	-	1
Headquarters, U. S. Air Force ATTN: AFOOP-SV-CG Washington 25, D. C.	1	-
Commander Rome Air Development Center ATTN: RAWIC - Mr. A. Stringham Griffiss Air Force Base, New York	1	-

<u>ADDRESSEE</u>	<u>REPORT</u>	<u>ABSTRACT</u>
<u>Department of the Air Force (cont'd)</u>		
Commander Rome Air Development Center ATTN: RAWIC - Mr. A. S. Zieno Griffiss Air Force Base, New York	2	2
Commander Rome Air Development Center (RAALD) ATTN: Documents Library Griffiss Air Force Base, New York	1	1
Headquarters Aeronautical Chart & Information Center (ACOC) U. S. Air Force 2nd and Arsenal St. Louis 18, Missouri	2	-
Commander Air Force Cambridge Research Laboratories ATTN: CRZGG L. G. Hanscom Field Bedford, Massachusetts	-	1
Commander-in-Chief Headquarters Strategic Air Command (DICC) Offutt Air Force Base, Nebraska	2	-
Commander Headquarters, Tactical Air Command Office of Civil Engineering (GR) Langley Air Force Base, Virginia	1	1
Commander 544th R. Technical Group (RTGTC) Offutt Air Force Base, Nebraska	2	2
Commander Air Proving Ground Center (PGAPI) Eglin Air Force Base, Florida	1	-
Commander Aeronautical Systems Division (ASNPRO) Wright-Patterson Air Force Base, Ohio	1	1

<u>ADDRESSEE</u>	<u>REPORT</u>	<u>ABSTRACT</u>
<u>Department of the Air Force (cont'd)</u>		
AFSC Scientific and Technical Liaison Office ATTN: Mr. Wesley I. Grieve c/o Department of the Navy Room 2305, Munitions Building Washington 25, D. C.	1	-
<u>Department of the Navy</u>		
Chief Bureau of Naval Weapons (FFRD-5) Department of the Navy Washington 25, D. C.	1	-
Director Marine Corps Landing Force Development Center Marine Corps Schools Quantico, Virginia	2	2
Commanding Officer ATTN: Evaluation Department U. S. Naval Photographic Interpretation Center 4301 Suitland Road Suitland, Maryland	1	-
Chief of Naval Research ATTN: Code 530 Department of the Navy Washington 25, D. C.	1	-
U. S. Naval Oceanographic Office Library (Code 1640) Washington 25, D. C.	2	-
<u>Department of Commerce</u>		
Director Coast and Geodetic Survey Washington 25, D. C.	1	-
ATTN: Ref. 453		
The Library Bureau of Public Roads Department of Commerce Washington 25, D. C.	1	-

<u>ADDRESSEE</u>	<u>REPORT</u>	<u>ABSTRACT</u>
<u>Department of the Interior</u>		
The Director U. S. Geological Survey Department of the Interior Washington 25, D. C.	1	-
Regional Forester, Region 1 U. S. Forest Service ATTN: Regional Engineer Missoula, Montana	1	-
<u>Department of Agriculture</u>		
U. S. Department of Agriculture Photogrammetric Service Center 701 Prince Street Alexandria, Virginia	1	-

AD
U. S. Army Engineer Geodesy, Intelligence and Mapping Research and
Development Agency, Fort Belvoir, Virginia - TESTS AND EVALUATION
OF AN EARTH CURVATURE CORRECTION DEVICE - I. R. Jarrett

Accession No.
Report 10-TR, 5 Feb 63, 17 pp, 6 illus
DA Task 44623501D95301 (formerly 8735-14-001-01)

Unclassified Report

Report covers the tests and evaluation of an internally developed Earth Curvature Correction Device for use with an anaglyphic projection-type stereoplotter in military mapping. Tests of the device were carried out on the High Precision Military Stereoplotter. Report presents evidence of the state of calibration of the plotter, the flatness of a stereoscopic grid model, and the accuracy of the curved surface developed by the correction device when compared to computed values. The corrections were measured by elevation readings in a grid model with the device in operation and by dial gauge readings in a model due to earth curvature proved to be sound and effective in a model due to earth curvature. Report concludes: (a) The basic principles incorporated in the device to compensate errors in operation on an anaglyphic projection plotter; and (b) refinements in the general design and minor changes in the moving parts of the Earth Curvature Correction Device should result in an attachment to the tracing table which will aid in obtaining accurate vertical height readings and greatly facilitate the contouring operation for topographic mapping.

UNCLASSIFIED

1. Mapping, Charting and Geodesy -
Global Mapping and Geodesy.

2. Contract - None.

AD
U. S. Army Engineer Geodesy, Intelligence and Mapping Research and
Development Agency, Fort Belvoir, Virginia - TESTS AND EVALUATION
OF AN EARTH CURVATURE CORRECTION DEVICE - I. R. Jarrett

Accession No.
Report 10-TR, 5 Feb 63, 17 pp, 6 illus
DA Task 44623501D95301 (formerly 8735-14-001-01)

Unclassified Report

Report covers the tests and evaluation of an internally developed Earth Curvature Correction Device for use with an anaglyphic projection-type stereoplotter in military mapping. Tests of the device were carried out on the High Precision Military Stereoplotter. Report presents evidence of the state of calibration of the plotter, the flatness of a stereoscopic grid model, and the accuracy of the curved surface developed by the correction device when compared to computed values. The corrections were measured by elevation readings in a grid model with the device in operation and by dial gauge readings in a model due to earth curvature proved to be sound and effective in a model due to earth curvature. Report concludes: (a) The basic principles incorporated in the device to compensate errors in operation on an anaglyphic projection plotter; and (b) refinements in the general design and minor changes in the moving parts of the Earth Curvature Correction Device should result in an attachment to the tracing table which will aid in obtaining accurate vertical height readings and greatly facilitate the contouring operation for topographic mapping.

UNCLASSIFIED

1. Mapping, Charting and Geodesy -
Global Mapping and Geodesy.

2. Contract - None.

AD
U. S. Army Engineer Geodesy, Intelligence and Mapping Research and
Development Agency, Fort Belvoir, Virginia - TESTS AND EVALUATION
OF AN EARTH CURVATURE CORRECTION DEVICE - I. R. Jarrett

Accession No.
Report 10-TR, 5 Feb 63, 17 pp, 6 illus
DA Task 44623501D95301 (formerly 8735-14-001-01)

Unclassified Report

Report covers the tests and evaluation of an internally developed Earth Curvature Correction Device for use with an anaglyphic projection-type stereoplotter in military mapping. Tests of the device were carried out on the High Precision Military Stereoplotter. Report presents evidence of the state of calibration of the plotter, the flatness of a stereoscopic grid model, and the accuracy of the curved surface developed by the correction device when compared to computed values. The corrections were measured by elevation readings in a grid model with the device in operation and by dial gauge readings in a model due to earth curvature proved to be sound and effective in a model due to earth curvature. Report concludes: (a) The basic principles incorporated in the device to compensate errors in operation on an anaglyphic projection plotter; and (b) refinements in the general design and minor changes in the moving parts of the Earth Curvature Correction Device should result in an attachment to the tracing table which will aid in obtaining accurate vertical height readings and greatly facilitate the contouring operation for topographic mapping.

UNCLASSIFIED

1. Mapping, Charting and Geodesy -
Global Mapping and Geodesy.

2. Contract - None.

AD
U. S. Army Engineer Geodesy, Intelligence and Mapping Research and
Development Agency, Fort Belvoir, Virginia - TESTS AND EVALUATION
OF AN EARTH CURVATURE CORRECTION DEVICE - I. R. Jarrett

Accession No.
Report 10-TR, 5 Feb 63, 17 pp, 6 illus
DA Task 44623501D95301 (formerly 8735-14-001-01)

Unclassified Report

Report covers the tests and evaluation of an internally developed Earth Curvature Correction Device for use with an anaglyphic projection-type stereoplotter in military mapping. Tests of the device were carried out on the High Precision Military Stereoplotter. Report presents evidence of the state of calibration of the plotter, the flatness of a stereoscopic grid model, and the accuracy of the curved surface developed by the correction device when compared to computed values. The corrections were measured by elevation readings in a grid model with the device in operation and by dial gauge readings in a model due to earth curvature proved to be sound and effective in a model due to earth curvature. Report concludes: (a) The basic principles incorporated in the device to compensate errors in operation on an anaglyphic projection plotter; and (b) refinements in the general design and minor changes in the moving parts of the Earth Curvature Correction Device should result in an attachment to the tracing table which will aid in obtaining accurate vertical height readings and greatly facilitate the contouring operation for topographic mapping.

UNCLASSIFIED

1. Mapping, Charting and Geodesy -
Global Mapping and Geodesy.

2. Contract - None.