

How real is quantum physics?



Michael Brenner

Studied Mechanical Engineering & Comparative Linguistics at Vienna University of Technology · Mar 6

Quantum physics is as real as any catechism: a catechism is the wilful distortion and misinterpretation of an underlying textual reality which makes it pseudo-scripture, and Quantum mechanics is pseudoscience, that is, the wilful distortion of an underlying physical reality. Contrary to catechisms, the pseudo science of quantum physics denies the existence of an autonomous underlying reality: *"In the Copenhagen interpretation of quantum mechanics, the objective reality has evaporated," (Heisenberg)*

I have already written extensively about the catechisms of Relativity and Quantum Mechanics, but this time I want to concentrate on the aspect of *"wilful distortion"* of the underlying physical as well historical reality, focusing on **Erwin Schroedinger**, who falsely is associated with the Quantum Mechanics of Max Born.

Let's begin with the most brazen of distortions in this case: the famous "cat of Schroedinger"

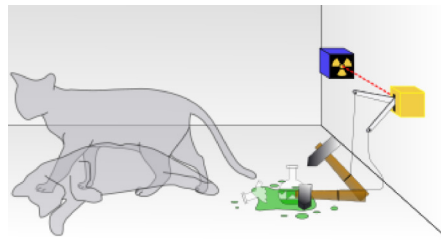

The Wikipedia article makes it sound as if Schroedinger came up with this thought experiment to *"teach"* Quantum mechanics, when in fact he used it to show how ridiculous, how ludicrous (*"burlesk"* in German, meaning ridiculous, ludicrous) the whole premise of quantum mechanics actually is.

This is the translation of the "cat paradox paper"

I.11 THE PRESENT SITUATION IN QUANTUM MECHANICS: A TRANSLATION OF SCHRÖDINGER'S "CAT PARADOX" PAPER

ERWIN SCHRÖDINGER (TRANS. JOHN D. TRIMMER*)

INTRODUCTION

This is a translation of Schrödinger's three-part

other two sides, the three altitudes, the radius of the inscribed circle, etc. Yet the representation differs intrinsically from a geometric figure in this impor-

Upvote · 2



1



... where Schroedinger makes it clear what he means:

One can even set up quite ridiculous cases. A cat is penned up in a steel chamber, along with the following diabolical device (which must be secured against direct interference by the cat): in a Geiger counter there is a tiny bit of radioactive substance, so small, that *perhaps* in the course of one hour one of the atoms decays, but also, with equal probability, perhaps none; if it happens, the counter tube discharges and through a relay releases a hammer which shatters a small flask of hydrocyanic acid. If one has left this entire system to itself for an hour, one would say that the cat still lives if meanwhile no atom has decayed. The first atomic decay would have poisoned it. The ψ -function of the entire system would express this by having in it the living and the dead cat (pardon the expression) mixed or smeared out in equal parts.

other respect (namely by changing the below).

Now this sheds some light on the proposition that I mentioned at the end of something very far-reaching: that all motions are measurable in principle. One can proceed along without this article of belief if one is constrained, in the interests of physics, to call in as dictatorial help the above philosophical principle, which no sensible person would fail to esteem as the supreme protector against empiricism.

Reality resists imitation through a multitude of naive realism and leans directly on the indubitable proposition that *actually* (for all practical purposes) after all is said and done there is no such thing as a continuous measurement. Then all our physical

And this comes after Schroedinger in vain tried to convince the scientific community that the whole Quantum thing is not only irrational, but the invention of a *"new physics"* for small scales is unnecessary. It is totally irrational to believe that Nature makes a scale distinction in the way she behaves, a scale distinction that is somehow geared to what we humans consider big or small.

It is equally irrational to believe that randomness, the abandonment of causality, can be the physical basis of a strong and resilient nature - an idea that becomes even more out of

or science with a catechism or beliefs:

In the words of Immanuel Kant: "*Causality is the basis of all scientific work. Causality is the condition that renders science possible.*"

and in the words of W. Heisenberg: "*The Law of Causality is no longer applied in quantum theory.*"

So, Quantum Theory is not science, it is the belief in an interpretation. Erwin Schroedinger shows us that this belief is unfounded and that classical physics is very well capable of describing what is called the "*small world of atoms*"

In 1928 Schroedinger holds 4 lectures in Berlin where the title alone would be enough to clarify things: it is all about "*Wave Mechanics*" and NOT about Quantum particle mechanics

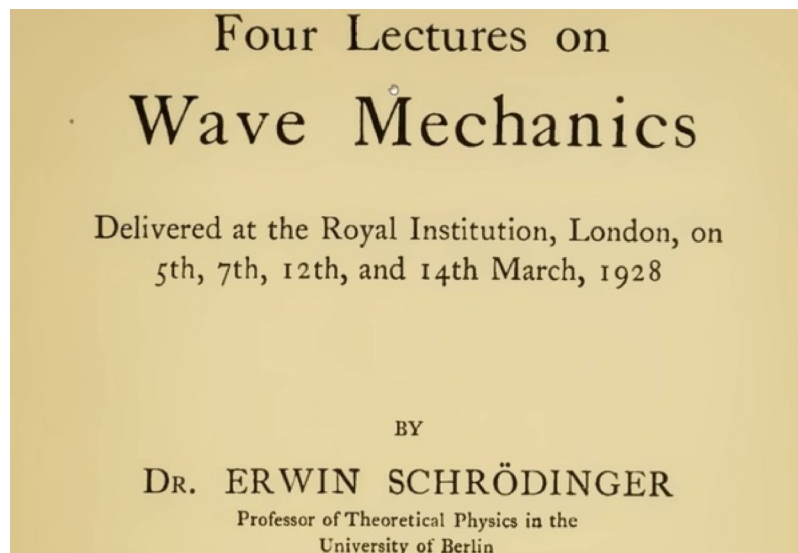

Schroedinger does point out though that "*ordinary mechanics*" is an approximation that does no longer hold for "*very small systems*" but what does he mean with that? With "*ordinary mechanics*" he means "*geometrical optics*" which treats rays like mechanical paths of mass points.....

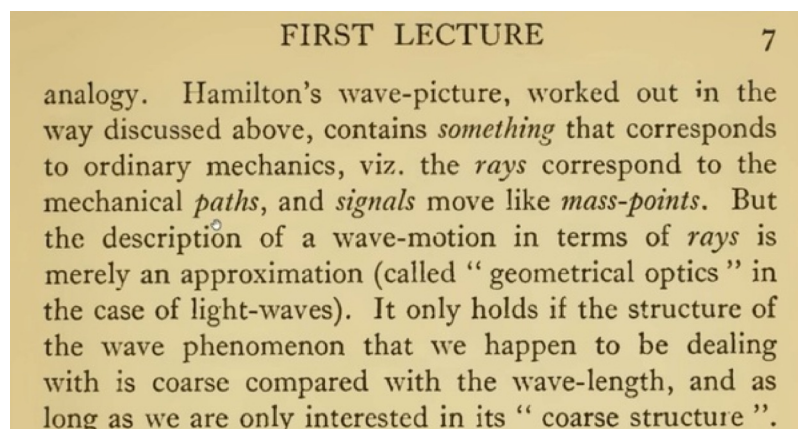

What Schroedinger suggests is replacing "*ray mechanics*" with "*wave mechanics*"....

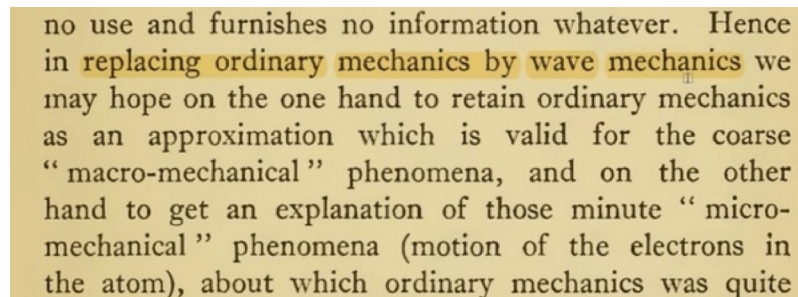



NOT PARTICLES, just the opposite of what the Quantum catechism teaches.

8 WAVE MECHANICS

The step which leads from ordinary mechanics to wave mechanics is an advance similar in kind to Huygens' theory of light, which replaced Newton's theory. We might form the symbolic proportion:

Ordinary mechanics : Wave mechanics
= Geometrical optics : Undulatory optics.

Typical quantum phenomena are analogous to typical wave phenomena like diffraction and interference.

Quantum theory treats the electron as a particle moving along a path and Schroedinger treats the electron as vibrational waves of a field of negative charge. And by waving this electron medium, he is able to explain what we observe experimentally about atoms, and it's consistent with "ordinary electrodynamics", that is, the classical electrodynamics of Maxwell.

18 WAVE MECHANICS

The hypothesis which we have to admit is very simple, namely that the square of the absolute value of ψ is proportional to an electric density, which causes emission of light according to the laws of ordinary electrodynamics. Since the square of the absolute value of ψ is formed by multiplying ψ by the conjugate complex quantity (which we will call $\bar{\psi}$), a glance at the expression (15) shows that the terms which compose $\psi\bar{\psi}$ contain the time in the form of cosine factors of the desired frequencies $\nu_k - \nu_{k'}$. More precisely, let us put, for the charge-density ρ ,

$$\rho = -e\psi\bar{\psi} = -e \sum_k \sum_{k'} c_k c_{k'} \psi_k \bar{\psi}_{k'} e^{2\pi i[(\nu_k - \nu_{k'})t + \theta_k - \theta_{k'}]}, \quad (18)$$

The correctness of our $\psi\bar{\psi}$ -hypothesis has been checked by calculating the $a_{kk'}$'s in those cases where the ψ_k 's are sufficiently well defined, namely in the case of the Zeeman and Stark effects. The so-called rules of selection and polarization and the intensity-distribution in these patterns are described by the $a_{kk'}$'s in the following obvious way, and the description is in complete agreement with experiment:

So just think about what Schroedinger did here. He just made quantum theory obsolete, because his wave equation describes the atomic experiments, and he does this using classical physics!

It is only par for the course of any catechism which ignores scriptures which could get uncomfortable, that Wikipedia, the mainstream canon of science scriptures has no dedicated page about Wave Mechanics

Article [Talk](#)

From Wikipedia, the free encyclopedia

Wave mechanics may refer to:

- the mechanics of [waves](#)
- the *wave equation* in quantum physics, see [Schrödinger equation](#)

See also [\[edit\]](#)

- [Quantum mechanics](#)
- [Wave equation](#)

*This disambiguation page lists articles associated with the title **Wave mechanics**.**If an internal link led you here, you may wish to change the link to point directly to the intended article.*Categories: [Disambiguation pages](#) | [Wave mechanics](#)

Here you are referred to a page about “*Schrodinger equation*”, where you are inevitably guided back to Quantum Physics - Which Schroedinger just showed was unnecessary, irrelevant and obsolete.

Schrödinger equation

Article [Talk](#)

From Wikipedia, the free encyclopedia

For a more general introduction to the topic, see [Introduction to quantum mechanics](#).

The **Schrödinger equation** is a [linear partial differential equation](#) that governs the [wave function](#) of a quantum-mechanical system.^{[1]:1–2} It is a key result in [quantum mechanics](#), and its discovery was a significant landmark in the development of the subject. The equation is named after [Erwin Schrödinger](#), who postulated the equation in 1925, and published it in 1926, forming the basis for the work that resulted in his [Nobel Prize in Physics](#) in 1933.^{[2][3]}

So when and how did Quantum physics become a “*separated physics*” to begin with, where did the split happen? It was Niels Bohr who introduced the Bohr atomic model, based on the rather medieval conceptualisation of Rutherford in this paper:

On the Constitution of Atoms and Molecules

N. Bohr,
Dr. phil. Copenhagen
(Received July **1913**)

Introduction

In order to explain the results of experiments on scattering of α rays by matter Prof. Rutherford¹ has given a theory of the structure of atoms. According to this theory, the atom consists of a positively charged nucleus surrounded by a system of electrons kept together by attractive forces from the nucleus; the total negative charge of the electrons is equal to the positive charge of the nucleus. Further, the nucleus is assumed to be the seat of

..... where he claims that “.....*classic electrodynamics is inadequate to describe the behaviour of systems of atomic size*”, the opposite of what Schroedinger demonstrated above. He spends 10 years trying to figure out “*quantum weirdness*” and in the end his math comes pretty close to matching experimental data, but at the cost of introducing a new physics: that of “*particles*” which are “*orbiting*” in a “*stationary*” state as well as being capable of instantaneously changing their position in space. Then comes Schroedinger and wipes it all off the table with classical mechanics. If we have two models, one introducing magic and one based on proven physics, it should be obvious which one would win out - but not in an agenda driven “*physical theology*” as Leibniz would call it. Nobel laureate Irving Langmuir had a somewhat more terse term of this: “*pathological science*”

Now, going back to Schroedinger's wave mechanics: his wave-based math was in complete agreement with the experiments, but there is a very major difference here. Schroedinger explained the atom without using the quantum conditions of “*stationary states*” or “*jumping electrons*”. In fact, he got rid of the electron particle itself and the orbital path that went around the nucleus.

"Let me say at the outset, that in this discourse, I am opposing not a few special statements of quantum mechanics / quantum theory held today (1950s), I am opposing as it were the whole of it, I am opposing its basic views that have been shaped 25 years ago, when Max Born put forward his probability interpretation, which was accepted by almost everybody. I don't like it, and I'm sorry I ever had anything to do with it." (Schrödinger E, The Interpretation of Quantum Mechanics. Ox Bow Press, Woodbridge, CN, 1995)

And also Heisenberg wisened up with age when he tells us "...that even major modifications of present physical theories would not transform them into the desired new theory, as quite different and novel ideas are required. Secondly, the impact of quantum theory and relativity theory on the minds of those scholars who helped found them during the first half of our century is conceivably such that they are imprisoned by these theories and thus cannot help but reason conformably, that is, in terms of traditional concepts; whereas the need is for a whole revolution of thought, which can only be carried through by nonconformists..." (Mercier 1971)

Obviously, here we are left with a white elephant in the room, and we better address it: the reality or fiction of quantum computing. After what was said above the answer should be self explanatory, but let's go for it: quantum computers also use the 0's and 1's of classical computers, but in a state of superposition, which Schroedinger showed us to be an utterly ludicrous idea. Let's not forget that the 0's and 1's refer to physical states of on and off, and now it is claimed that a physical gadget can be "on" and "off" at the same time - but you can't access it, because then you force the collapse of the superimposed state and that means the only way to deal with it is "believe it" and that is theology, "physical theology".

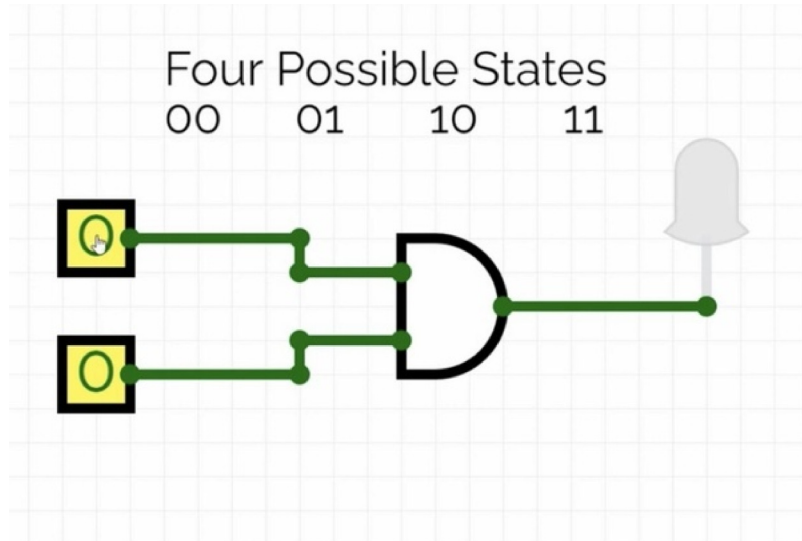

Here it is claimed that all 4 possible states arrive at the gate at the same time..... but you can never know, because you always ever get a Zero OR a One the moment you try to access the information - by definition of the very theory that proposes such devices.

It can't be overstressed that Schroedinger's wave mechanics is NOT quantum mechanics, it is the opposite of it. What the Quantum camp did was hijacking Schroedinger's wave equation and pin it on their lapel, and it was Max Born to do so in this paper:



[Scattering!]

Max Born

21 July 1926

Abstract

The Schrödinger form of Quantum Mechanics permits one to define in a natural way the frequency of occurrence of a state with help of the intensity of the associated eigenfunction. This understanding carries over to the theory of scattering where the transition probability is determined through the asymptotic cases of aperiodic solutions.

Here we see him use the term "*Schroedinger form of quantum mechanics*" - which doesn't exist, it is the "*Schroedinger form of wave mechanics*" - before presenting a third interpretation based on an idea he got from Einstein that determines the "*probability*" of a photon. But Einstein had already shown how problematic it can be to apply statistics to physical systems in his paper about Brownian motion: there he made the latent heat of a system responsible for the displacement of a particle through viscous medium - which causes friction, the prime dissipater of energy in nature - without the system losing heat, that is cooling. Einstein's probability approach thus cannot represent physical reality. If you would propose to a plenum of physicists an explanation of any natural phenomenon that violated the way nature operates so blatantly, they would react "*averse*" to put it mildly, they would cringe and drive you off the premises with wet rags.

Schroedinger reacts similarly to max Born's hijacking of his equation in this paper:

The Exchange of Energy according to Wave Mechanics

(*Annalen der Physik* (4), vol. 83, 1927)

Here he is "*averse*" to this conception.....

be the case. According to Born, the alteration of the "probability field" as time goes on is compulsorily (causally) controlled by the wave equation, and consequently the alteration in time of the "probability amplitudes" is controlled by the equations (9). Hence the objection to reversal mentioned in § 3 now applies to the alteration in time of the probability amplitudes. So far as I can see, we can therefore never reach a one-way (irreversible) course without a supplementary hypothesis about the relative probability of the various possible distributions of the initial values of the probability amplitudes. I am averse to this conception, not so much on account of its complexity as on account of the fact that a theory which demands our assent to an absolute primary probability as a law of Nature should at least repay us by freeing us from the old "ergodic difficulties" and enabling us to understand the one-way course of natural processes without further supplementary assumptions.

Zürich, Physical Institute of the University.
(Received June 10, 1927.)

... in the German original he uses the word "*zurückschrecken*", which is a tad more emotional than just being averse: it's more like finding something "*cringeworthy*"



der Wahrscheinlichkeitsamplituden. So weit ich sehe, kann man also niemals zu einem einsinnigen (nichtumkehrbaren) Ablauf gelangen ohne eine Zusatzhypothese über die relative Wahrscheinlichkeit der verschiedenen möglichen Anfangswertverteilungen der Wahrscheinlichkeitsamplituden. Vor dieser Begriffsbildung schrecke ich zurück, nicht sowohl wegen ihrer Kompliziertheit, als deshalb, weil man von einer Theorie, welche eine absolute, primäre Wahrscheinlichkeit als Naturgesetz postuliert, verlangen sollte, daß sie uns um diesen Preis wenigstens von den alten „Ergodenschwierigkeiten“ befreie und den einsinnigen Ablauf des Naturgeschehens ohne weitere Zusatzannahmen verstehen lasse.

Zürich, Physikalisches Institut der Universität.

(Eingegangen 10. Juni 1927)

So here we have with Max Born one man's opinion on how one can force the idea of a quantum particle into a classical wave equation. Both quantum mechanics and quantum computing depend solely on this man's opinion which is expressed in this paper:

I.2 ON THE QUANTUM MECHANICS OF COLLISIONS

[Preliminary communication]*

MAX BORN

Here is where quantum mechanics begins:

If one translates this result into terms of particles, only one interpretation is possible. $\Phi_{n,m}(\alpha, \beta, \gamma)$ gives the probability* for the electron, arriving from the z -direction, to be thrown out into the direction designated by the angles α, β, γ , with the phase change δ . Here its energy τ has increased by one quantum $h\nu_{nm}^0$ at the cost of the energy of the atom (collision of the first kind for $W_n^0 < W_m^0, h\nu_{nm}^0 < 0$; collision of the second kind $W_n^0 > W_m^0, h\nu_{nm}^0 > 0$).

It is the opinion that Schroedinger's wave function gives the probability of the location for a quantum particle. This is called the Born rule, and there is no scientific hint, justification or proof that it's reflecting physical reality. One has to ask how Born comes to the conclusion that there is "only one interpretation possible"? and that comes from trying to manhandle a wave function and force feed it to particles:

Here we see two waves moving in opposite directions:

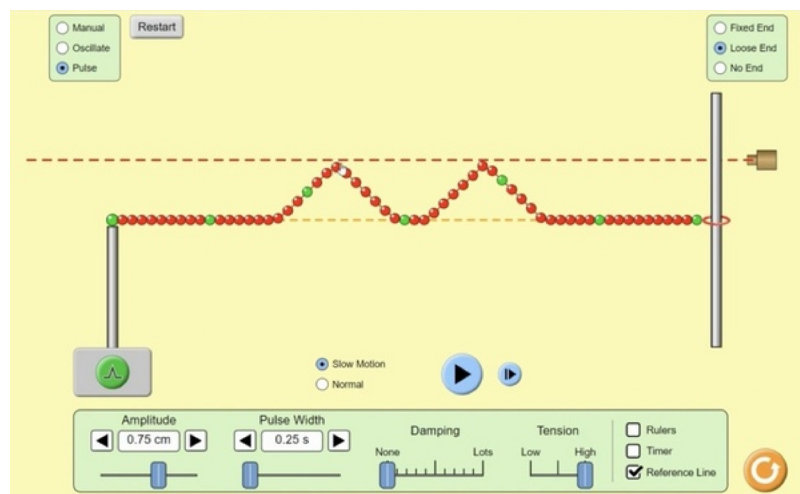

.... and here we see their "superposition" which is a natural occurrence in wave mechanics and called "interference", in this case "constructive interference"

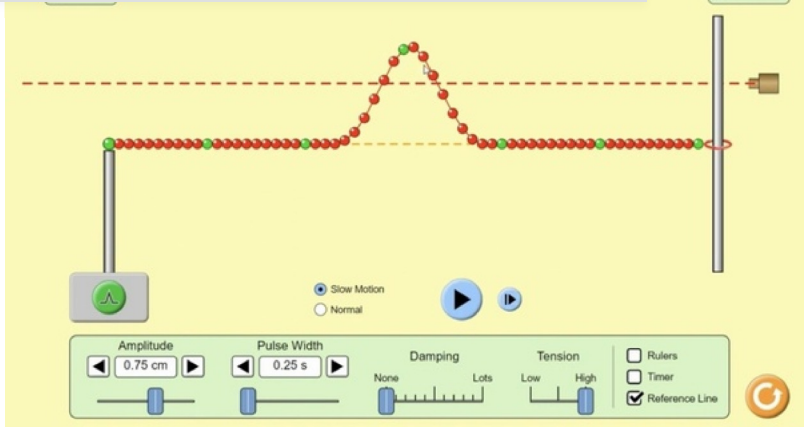

Now think about these waves as particles and how two particles would occupy the same space at the same time: not happening, so now you have to get creative and say: wait a little, these waves are not a waving medium, but waving probabilities, these are "probability amplitudes" that interfere..... but that is not physics, that is not even good philosophy, that is how bible exegetes force interpretations of scripture into a framework of wishful thinking.

Addendum: I have written about the Planck light quantum in another answer, but it begs to be mentioned here briefly, because many associate Planck with Quantum Theory: $E=hf$ is not about a quantum particle, it is per necessity of the **time frame** "Frequency" [f] a process and not a "thing", which would be contained in a **space frame** "Volume". The equation describes one second worth of energy of a process, that of oscillation of EM radiation.

Color	Wavelength	Frequency	Photon energy
violet	380–450 nm	668–789 THz	2.75–3.26 eV
blue	450–495 nm	606–668 THz	2.50–2.75 eV
green	495–570 nm	526–606 THz	2.17–2.50 eV
yellow	570–590 nm	508–526 THz	2.10–2.17 eV
orange	590–620 nm	484–508 THz	2.00–2.10 eV
red	620–750 nm	400–484 THz	1.65–2.00 eV

707 views · View 2 upvotes

1 of 17 answers



Add a comment...

Add comment



Laszlo Petruska · Mar 6
Great insights.



1



Reply



View 16 other answers to this question >

About the Author



Michael Brenner

Studied Mechanical Engineering & Comparative Linguistics at Vienna University of Technology

939K content views 9.9K this month

Quora



Following · 564

Notify me

Ask question

