

thology Photography Fiction Fishing
Christianity Art Cooking Essays
Buddhism Freemasonry Medicine Biology
Music Ancient Egypt Evolution
Carpentry Physics Dance Geology
Metaphysics Fitness Yoga Marketing Confidence
Immortality Biographies Poetry
Psychology Witchcraft Electronics
Chemistry History Law Accounting
Philosophy Anthropology Alchemy Drama
Quantum Mechanics Atheism Sexual
Personal Health Ancient History Criminal
Empire Paleontology Research Astrology
Metaphysics Investment Archaeology

Forgotten Books

— www.forgottenbooks.com —

Copyright © 2016 FB &c Ltd.

All rights reserved. No part of this publication may be reproduced, distributed, or transmitted in any form or by any means, including photocopying, recording, or other electronic or mechanical methods, without the prior written permission of the publisher, except in the case of brief quotations embodied in critical reviews and certain other noncommercial uses permitted by copyright law.

PREFACE

THERE are many books on Navigation available for the use of the student, and among them some are exceedingly good. Why, then, add yet another volume to a mass of literature already sufficiently, and more than sufficiently, large? Well, it seemed to me that for many reasons another work designed on somewhat novel principles might be useful. Most writers have treated the subject from the point of view of addressing themselves either to the highly educated or to the totally uneducated, and there is, I think, room for a treatise designed to meet the requirements of those who lie between the two extremes; men who, while ignorant of mathematics and astronomy, possess intelligence and a certain amount of rudimentary knowledge.

Navigation is in many respects a peculiar subject. All the problems being based upon the higher mathematics and astronomy, the solutions of them can be calculated and formulated only by men thoroughly conversant with those sciences; but Navigation has to be put in practice by men who are not, and cannot be expected to be possessed of much knowledge of those matters. Moreover, mariners have to work their problems in a hurry, and frequently under adverse circumstances. To sit in a

PREFACE

THERE are many books on Navigation available for the use of the student, and among them some are exceedingly good. Why, then, add yet another volume to a mass of literature already sufficiently, and more than sufficiently, large? Well, it seemed to me that for many reasons another work designed on somewhat novel principles might be useful. Most writers have treated the subject from the point of view of addressing themselves either to the highly educated or to the totally uneducated, and there is, I think, room for a treatise designed to meet the requirements of those who lie between the two extremes; men who, while ignorant of mathematics and astronomy, possess intelligence and a certain amount of rudimentary knowledge.

Navigation is in many respects a peculiar subject. All the problems being based upon the higher mathematics and astronomy, the solutions of them can be calculated and formulated only by men thoroughly conversant with those sciences; but Navigation has to be put in practice by men who are not, and cannot be expected to be possessed of much knowledge of those matters. Moreover, mariners have to work their problems in a hurry, and frequently under adverse circumstances. To sit in a

comfortable chair in a warm and cosy room, and leisurely work out abstract calculations from imaginary observations, is quite a different thing from taking real observations on a wet, slippery, and tumbling deck, and working them in a dimly-lit cabin full of confusion and noise, and with little time to spare for the operation.

Therefore, for the convenience of the practical man, it is necessary that the scientific man should reduce the formulas to the simplest possible dimensions. With those formulas the practical man can find his way about all right if he learns and remembers them, and how to work them; but, as it is very difficult to remember a lot of formulas learnt by heart, it is highly desirable that the practical man should have some idea of what he is doing and why he does it.

Few things appear to be more difficult than for one well up on any subject of a scientific character to impart his knowledge to another who is scientifically ignorant. A thorough past-master may succeed in explaining matters popularly in language which can be understood by the many; but the expositions of writers on highly technical subjects—whether connected with Science, Art, Philosophy, or anything else—are frequently rendered so obscure, by the lavish employment of highly technical language, as to be unintelligible except to the educated few.

All the Epitomes—Norie's, Inman's, Raper's, and many other books—give explanations of the various problems in Navigation somewhat too minute and too diffuse, I venture to think, to be attractive to the ordinary reader, with the result that the formulas are generally learnt by heart. A man must be gifted with a gigantic memory if he can remember how to work everything from

Logarithms to Lunars. Moreover, in most works the definitions, though of course absolutely scientific and correct, are so scientific and so correct as to be somewhat unintelligible to the unscientific person, whose ideas on geometry are very hazy. Books such as Captain Martin's and Mr. Lecky's are most valuable, but they preconceive a considerable amount of knowledge on the part of the student. Books such as Rosser's 'Self-Instructor' are equally valuable in their way, but they seem to have been written on the supposition that everything must be learnt by heart and nothing understood by brain. So it occurred to me that an attempt to give—conversationally—as if Pupil and Teacher were talking—sufficient explanation of navigational problems to throw some light upon the meaning of the formulas used, and some additional information for the benefit of those desirous of obtaining it, might be useful; and, having myself started to study Navigation somewhat ignorant of the sciences upon which it is founded, I determined to try and impart to others in a similar plight what knowledge I have gathered together.

My definitions and explanations may be sometimes scientifically inaccurate. Let that pass. My purpose is gained if they convey an accurate idea.

That portion of the work which treats of the 'Day's Work,' the 'Sailings,' and so on, contains a very short treatise on plane right-angled triangles, by the solution of which all such problems are worked. The student need not read it if he does not want to, and if it bothers him he had much better not do so. The method of working every problem is given, and for all practical purposes it is sufficient if he learns and remembers that. The learning is really easy enough; it is the remembering

that is difficult. But, if the imaginary person I am endeavouring to instruct will read the chapter on Plane Trigonometry, I think it will help him greatly in learning how to work the problem; or if he learns the working of the problem first, and then wants 'to know the reason why,' a perusal of it may give him sufficient insight to enable him easily to remember how every problem is to be solved. If my reader wishes to obtain an Extra Master's certificate of competency he must learn enough of Plane Trigonometry to enable him to construct plane triangles and solve them, for that will be required of him. Of course if he is well up in Trigonometry, or has time to master that angular science, so much the better; but if such is not the case, I think he will find in the following pages all the information necessary for his purpose.

In the same way Nautical Astronomy is preceded by a sketch of the movements of the heavenly bodies, and contains a short chapter on Spherical Trigonometry; it is not the least necessary for the student to read it; but if he does so before or after tackling the various problems, it will, I think, help him to understand their nature and the methods by which they are solved. Be it remembered that even a very little and very hazy knowledge of this kind is sufficient to ensure that you do not forget how a problem is to be worked. Moreover, should a 'blue ticket' be the object of ambition, the aspirant to such honours will have to solve some spherical triangles, and to draw the figures appropriate to some of the problems. In this instance also it is better that the subject should be thoroughly studied and understood; but if the prospective Extra Master has not the time nor inclination

to do so, I think that the little I say will answer all the requirements of the case.

Most problems can be solved in various ways. I have given the formula which is, in my opinion, the simplest ; but I claim no infallibility for my opinion.

Norie's Tables are used throughout, except in some portions of the Double Altitude and Lunar problems, because I happened to be taught with those Tables, and have always used them ; every reference to a Table therefore refers to Norie, but as many men prefer Inman or Raper a comparative statement will be found on page xxiii, giving the equivalent in Inman and Raper to every Table in Norie.

I have treated what may be called the mechanical part of the business—for instance, the use of the lead and the log—very shortly. Such matters can be learnt only by practice, and if information is required concerning them, are they not fully and clearly explained in the Epitomes and in manuals and books of instruction innumerable ?

I have not touched upon the Rule of the Road at sea, though it is scarcely necessary to mention that it is of the first importance that a seaman should be intimately acquainted with it. Such knowledge comes only from habit and experience. I would only say that before going up for examination, a candidate should be thoroughly drilled on this subject by a competent instructor. A man whose knowledge and judgment may be perfectly reliable at sea, may be much puzzled when he finds himself seated opposite an examiner playing about with small toy ships on a table. Captain Blackburne has published a little book on the subject, which will be found of great service to the student or candidate.

PREFACE

I have endeavoured to take the simpler problems first, and lead gradually up to the more difficult ones ; but this is not easy of accomplishment, as the problems overlap each other so frequently. And I have treated of the whole subject, from a Mate's to an Extra Master's work, which has not, I think, been attempted in any single work.

I have also tried to explain, as far as possible, how every portion of a problem is worked as the case crops up in the problem ; for nothing is more bothersome than having to constantly turn back and refer to some previous explanation.

The explanation of every diagram is, wherever possible, placed on the same page with the diagram or on the opposite page, for I have found it very troublesome to have to turn over pages to find what angle so-and-so, or line this or that is ; and I opine that others also must have found it equally troublesome. This method of treating the subject involves much repetition, but repetition is not vicious ; on the contrary, when something has to be remembered, it is good, and I have taken some pains not to avoid repetition.

I do not flatter myself that the difficulty of self-instruction is entirely got over in this work, but I hope it may go some way towards attaining that desirable end. As far as practical work at sea is concerned, very little, if any, supplementary instruction would be necessary in order to enable anyone to find his way about ; but for the Board of Trade Examination the personal instruction of a good master is certainly desirable, for in most cases the problems, as given in the examination, are far more puzzling than as they present themselves at sea. For one thing, at sea you know whereabouts you are, and any

large mistake manifests itself in the working of a problem ; but in the examination room no such check upon inaccuracy exists.

As an amateur I have written mainly for amateurs ; but if this book proves of any assistance to those whose business is upon the sea, I shall indeed be pleased.

For convenience sake the book is divided into two volumes, a big volume being cumbrous to handle. The first volume contains Logarithms, the Sailings, a Day's Work, the Use of the Compass, some chart work, and the simpler nautical astronomical problems. The second volume treats of other nautical astronomical problems, and magnetism ; it gives further information on the subject of charts, and shows how the working formulas are deduced ; and it contains numerous exercises, together with the data from the Nautical Almanac of 1898 necessary to work them.

HINTS TO CANDIDATES

No particular and regular sequence is, I believe, followed in the examination papers in the order in which problems are given; but I fancy they generally come in something like the following somewhat appalling procession :

For Mates and Masters

1. Multiplication by common Logs.
2. Division by common Logs.
3. Day's Work.
4. Latitude by Meridian Altitude of the Sun.
5. Parallel Sailing.
6. Mercator's Sailing.
7. Time of High Water.
8. Amplitude.
9. Time Azimuth.
10. Longitude by Sun Chronometer and Altitude Azimuth.
11. Time of Star's Meridian passage.
12. To find names of Stars from Nautical Almanac within a given distance of the Meridian at a certain time, and also the distance they pass North or South of the Zenith.
13. Compute the Obs. Mer. Alt. of a Star for a given place.
14. Latitude by Meridian Altitude of a Star.
15. Star Time Azimuth.
16. Latitude by Reduction to the Meridian.
17. Sumner.

18. Latitude by Pole Star.
19. Latitude by Moon's Meridian Altitude.
20. Correction for soundings.

For Extra Master's Certificate

21. Longitude and Error of Chronometer by Lunar Observation.

22. Latitude by Double Altitude.

23. Position of Ship by Double Chronometer Problem.

24. Great Circle Problem.

25. Error of Chronometer by Altitude of Sun or that of any other heavenly body.

26. Solution of a right-angled plane triangle.

27. Solution of an oblique-angled plane triangle.

28. Solution of a right-angled spherical triangle.

The manner in which problems are presented is constantly varied; different expressions and different words are employed to denote the same facts. You may be told that the Sun is bearing North, or that the observer is South of the Sun, or that the Sun is South of the Zenith. You may be given the date in Astronomical Time, or in Civil Time, in Apparent Time or in Mean Time at Ship or at Greenwich. You may be given the absolute date such and such a time, Mean or Apparent at Ship, or you may be told that a Chronometer showed so many hours, minutes, seconds, which Chronometer had been found to be so much fast or slow on Apparent Time at Ship at some earlier period, since when the Ship had run so many miles on such and such a course, and you would have to find the Ship date by allowing for the Difference of Longitude due to the run. In fact, the Examiners ring the changes as much as possible, and very properly so, for it is but right that candidates should not only work the problems but also show an intelligent knowledge of what they are doing. Nevertheless, these changes are apt to

be puzzling. They would not puzzle anyone in actual practice at sea; but the nervous condition of most men is apt to fall below the normal, and the brain to become unnaturally confused when they are shut up in an examination room for long hours, and so much depends upon their efforts. Therefore, read the statement of each problem very carefully, and if you notice anything unusual, anything you do not quite understand in the wording, just think it over quietly until you quite understand what you have got to do; translate it, as it were, in your head into the language you have been accustomed to. Don't hurry over your work. Remember that it takes a long time to discover an error in a problem returned, and that, having found it, you may have to do most of the work over again.

ABBREVIATIONS

The points of the compass are indicated by their initial letters. *Vide* the compass card.

<p>Log. . . = Logarithm. Mag. . . = Magnetic. Corr. . . = Correct. Dev. . . = Deviation. Var. . . = Variation. Az. . . = Azimuth. Amp. . . = Amplitude. Tr. . . = True. Lat. . . = Latitude. Colat . . = Complement of the Latitude or Co. Latitude. Long. . . = Longitude. Dist. . . = Distance. Diff. . . = Difference. Diff. Lat. . . = Difference of Lati- tude. Diff. Long. . . = Difference of Lon- gitude. Dep. . . = Departure. Mer. . . = Meridian or Meri- dional. Mer. Diff. Lat. = Meridional Differ- ence of Latitude. R. A. . . = Right Ascension. Dec. . . = Declination. S.-D. . . = Semi-Diameter. H. P. . . = Horizontal Paral- lax. Z. . . = Zenith. P. . . = Pole. Z. D. . . = Zenith Distance. P. D. . . = Polar Distance. Alt. . . = Altitude.</p>	<p>Par in Alt. . . = Parallax in Alt- tude. ☉ . . . = The Sun. — . . . = The Sun's Lower Limb. ☽ . . . = The Sun's Upper Limb. R. A. M. ☉ . . = Right Ascension of the Mean Sun. Tr. Alt. . . = True Altitude. App. Alt. . . = Apparent Altitude. Obs. Alt . . = Observed Altitude A. T. S. . . = Apparent Time at Ship. M. T. S. . . = Mean Time at Ship. E. T. . . = Equation of Time A. T. G. . . = Apparent Time at Greenwich. M. T. G. . . = Mean Time at Greenwich. Sid. Time . . = Sidereal Time (the same thing as R.A.M. ☉ in Nau- tical Almanac). Sid. Time of . . = Sidereal Time of Obs. . . Observation (same thing as R.A. of Meridian). P. A. . . = Polar Angle. H. A. . . = Hour Angle.) or (. . = The Moon. ☾ . . . = Moon's Lower Limb.</p>
---	--

$\bar{\text{M}}$. = Moon's Upper Limb.	$\odot - \text{?}$. = Sun and Moon's near Limb.
*	. = A Star or Planet.	$* - \text{?}$. = Star and Moon's far Limb.
. L.	. = Far Limb.		
N. L.	. = Near Limb.	$* - \text{C}$. = Star and Moon's near Limb.

SYMBOLS

\div Plus. $-$ Minus. $=$ Equal. \times Multiplication. \div Division. \sim Difference. $:$ is to or to. $::$ so is. x An unknown quantity. θ An unknown auxiliary angle.

ABBREVIATIONS OF TRIGONOMETRICAL RATIOS

Sin = Sine; Cos = Cosine; Tan = Tangent; Cot = Co-tangent;
 Sec = Secant; Cosec = Cosecant; Vers = Versine; Hav = Haversine

CONTENTS

OF

THE FIRST VOLUME

	PAGES
PREFACE	v-xi
HINTS TO CANDIDATES	xii-xiv
LIST OF ABBREVIATIONS USED	xv-xvi
COMPARATIVE STATEMENT OF NORIE, INMAN, AND RAPER TABLES	xxiii-xxv

PART I

CHAPTER I

ARITHMETIC

PROPORTION, OR RULE OF THREE	2-6
DECIMAL FRACTIONS; ADDITION, SUBTRACTION, MULTIPLI- CATION, AND DIVISION	6-14
REDUCTION OF DECIMALS	14-18

CHAPTER II

LOGARITHMS

CHARACTERISTIC OR INDEX; MANTISSA	19-20
LOGS. OF NATURAL NUMBERS	20-21
NATURAL NUMBERS OF LOGS.	21-23
MULTIPLICATION AND DIVISION BY LOGS.	23-25

	PAGES
LOGS. OF NUMBERS CONSISTING OF MORE THAN FOUR FIGURES	25-29
LOGS. OF NUMBERS COMPOSED OF INTEGERS AND DECIMALS, OR OF DECIMALS ONLY: THEIR MULTIPLICATION AND DIVISION	29-36
PROPORTIONAL LOGS.	36-37
THEORY OF LOGS.	37-38

CHAPTER III

INSTRUMENTS USED IN CHART AND COMPASS WORK

THE MARINER'S COMPASS	39-40
AZIMUTH MIRROR	41-42
THE LEAD AND LEAD LINE	42-45
THE LOGSHIP AND LOG LINE; HARPOON AND TAFFRAIL LOG	45-48
PARALLEL RULERS, DIVIDERS, PROTRACTORS	48-50
THE PELORUS	50
STATION POINTER	51

CHAPTER IV

THE PRACTICAL USE OF THE COMPASS

VARIATION AND DEVIATION	53-56
TO FIND COMPASS COURSES FROM TRUE COURSES AND TRUE COURSES FROM COMPASS COURSES	56-62
TO TURN POINTS INTO DEGREES, &c., AND <i>VICE VERSA</i>	64-65
MOVABLE COMPASS CARD	65-68
TO ASCERTAIN THE DEVIATION	68-73
NAPIER'S DIAGRAM	74-77
EXAMPLES	77-82

CHAPTER V

THE SAILINGS

THE TRAVERSE TABLES AND HOW TO USE THEM	83-84
TABLE XXV. AND HOW TO USE IT	85-88



THIS PAGE IS LOCKED TO FREE MEMBERS

Purchase full membership to immediately unlock this page

SAVE \$3,999,994

Did you know we sell
paperback books too?

To buy our entire catalog
in paperback would cost
over \$4,000,000

Access it all now for
\$8.99/month

*Fair usage policy applies

Continue

CHAPTER VIII

CHARTS

	PAGES
MAGNETIC AND TRUE CHARTS	206-207
HOW TO FIND THE SHIP'S POSITION ON THE CHART	207-208
TO FIND THE SHIP'S PLACE BY BEARINGS OF THE LAND	208-213
TO ALLOW FOR A CURRENT	213-214
SUMMARY OF POINTS TO BE CONSIDERED IN CHARTING PROBLEMS	215
THEORY OF MERCATOR'S CHART	216-221
TO CONSTRUCT A MERCATOR'S CHART FOR A GIVEN LATITUDE	221-223

PART II

NAUTICAL ASTRONOMY

CHAPTER IX

DEFINITIONS

GEOMETRICAL AND TRIGONOMETRICAL	225-226
GEOGRAPHICAL	226-227
ASTRONOMICAL	228-230

CHAPTER X

INSTRUMENTS USED IN NAUTICAL ASTRONOMY

DESCRIPTION OF THE SEXTANT, VEERNIER, INDEX GLASS, HORIZON GLASS	231-233
HOW TO OBSERVE WITH THE SEXTANT	233-234
READING THE ANGLE	234-237
HOW TO ADJUST INDEX GLASS AND HORIZON GLASS	237-238
HOW TO DETERMINE INDEX ERROR	239-241
THEORY OF SEXTANT	241-243
CHRONOMETER	244-245
ARTIFICIAL HORIZON	245-246

CHAPTER XI

MOVEMENTS OF THE HEAVENLY BODIES

	PAGES
THE TERMS 'EASTERLY' AND 'WESTERLY'	247-248
ROTATION AND REVOLUTION OF THE EARTH	248-250
INCLINATION OF EARTH'S AXIS AND ITS EFFECTS	250-251
LATITUDE, LONGITUDE, RIGHT ASCENSION, DECLINATION	251-253
APPARENT TIME	253-254
SIDEREAL AND SOLAR TIME	254-256
THE PLANETS	256-257
THE MOON	257-260
GREENWICH TIME ALWAYS TO BE USED WITH THE NAUTICAL ALMANAC	260-261
ENGLISH'S GLOBE STAR-FINDER	261-265

CHAPTER XII

LATITUDE BY MERIDIAN ALTITUDE OF
THE SUN

THE SIMPLE PROBLEM WITHOUT ANY CORRECTIONS	266-268
CORRECTION FOR DIP	268-269
" " SEMI-DIAMETER	270-271
" " REFRACTION	271-272
" " PARALLAX	272-273
" " CHANGE OF DECLINATION SINCE GREENWICH NOON	273-274
FINDING THE LATITUDE, APPLYING ALL THE CORRECTIONS AS REQUIRED BY BOARD OF TRADE	275-279
PRINCIPLE INVOLVED IN DETERMINATION OF LATITUDE	280-284

CHAPTER XIII

LONGITUDE BY SUN AND CHRONOMETER

APPARENT AND MEAN TIME	286-287
LONGITUDE MEASURED BY ARC ON EQUATOR OR ANGLE AT POLE	288-289
NAMING LONGITUDE	290
CORRECTION OF ELEMENTS	291

	PAGES
FORMULAS	292-293
USE OF TABLES XXXI. AND XXXII.	293-294
EAST AND WEST HOUR ANGLES	294-295
CORRECTION OF CHRONOMETER	296-299
FULL STATEMENT OF METHOD OF WORKING PROBLEM AND EXAMPLES	300-307
HOUR ANGLES BEYOND LIMITS OF TABLES XXXI. AND XXXII.	308
JOHNSON'S TABLES	309-310
EXAMPLE OF FINDING SHIP'S POSITION	311-315
PRINCIPLE OF METHOD OF FINDING LONGITUDE	316-321

THE CONVERSE PROBLEM: TO FIND THE ERROR OF CHRONO- METER FROM A KNOWN LONGITUDE	322-324

CHAPTER XIV

OBSERVATIONS USED FOR MAKING COMPASS CORRECTION

AMPLITUDE	326-329
ALTITUDE AZIMUTH OF THE SUN	329-336
TIME AZIMUTH OF THE SUN BY TABLES	337-341
TIME AZIMUTHS OF A STAR OR PLANET	341-342
FORMULA FOR TIME AZIMUTH	342-344

CHAPTER XV

REDUCTION TO THE MERIDIAN

METHOD AND FORMULAS TO BE EMPLOYED	345-350
RIGOROUS FORMULA FOR EX-MERIDIANS	350-351
LATITUDE BY MERIDIAN ALTITUDE OF A STAR	351-352
SUMMARY OF THE ORDINARY PROBLEMS AND NECESSARY FORMULAS	352-354

COMPARATIVE STATEMENT OF NORIE, INMAN, AND RAPER TABLES

NORIE ED. 1896			INMAN ED. '92		RAPER ED. '98	
Table	Page	Subject	Table	Page	Table	Page
A	1*	To convert Arc into Time	26	112	17	647
B	1*	To convert Time into Arc	26	112	18	647
C	2*	Factor to correct Var. in 1 ^h of ☉ R. A. and Dec., and E. T.	—	—	—	—
D	2*	Augmentation of ☽ S. D.	22	66	42	685
E	2*	Reduction of ☽ H. P. for figure of Earth	38	466	41	685
I.	1-16	Traverse Table for Points and Quarter Points	3	2-38	—	—
II.	18-107	Traverse Table for degrees	3	2-38	1	432-521
III.	108-114	Meridional Parts	7	42-50	6	533-537
III.*	115	Correction of Mean Ref. for Barometer and Thermometer	13	55	32, 33	672-673
IV.	116	Mean Refraction	12	53-54	31	671
V.	116	Dip of Sea Horizon	9	51	30	671
VI.	116	☉ Parallax in Alt.	14	55	34	673
VIII.	116	Dip of Shore Horizon	10	51	35	673
IX.	117	Correction of Obs. Alt. ☉ to find Tr. Alt.	17	58	38	675
X.	118-121	☉ Dec. from 1888 to 1899	18	59-60	60	698, 699
XI.A	118, 121	To correct ☉ Dec. at NOON at Sea	—	—	19	648
XII.	119, 120	To correct ☉ Dec. for changes in periods of four years	—	—	60A	700
XIII.	122, 123	Equation of Time 1888-1895	29	116, 117	62	703-704
XIV.	124	Mean Places of Principal Fixed Stars	19	61, 62	63	705
XIV.*	125	☉ Mean R. A.	—	—	61	701-702
XV.	125	Correction of Obs. Alt. Star to find Tr. Alt.	—	—	38	675
XVI.	126	Correction of ☽ Mer. Passage	23	66	28	665
XVI.*	126	For finding Time of High Water	—	—	—	—
XVII.	127	To find the Lat. by Alt. of Pole Star	21	63-65	51	692
XVII.*	127	Correction of Lat. deduced from Table XVII.	—	—	—	—
XVIII.	128-130	{ Correction of App. Alt.'s of Sun and Stars	12, 16	{ 53-54 56-57	—	—
XIX.	131	For reducing Long. into Time and the reverse	—	—	17, 18	647
XX.	131	Distance of Sea Horizon for Different Heights	8	51	8	539
XXI.	132-133	For reducing ☉ Dec. to any Greenwich Date	—	—	21	649-654
XXII.	134-135	For reducing ☉ R. A. to any Greenwich Date	—	—	21	649-654
XXIII.	136	Log. Sines, Tans, and Secs to every Quarter Point	—	—	—	—
XXIV.	136-151	Logs. of Numbers	35	395-422	64	706-723
XXV.	152-266	Log. Sines, Tangents, Secants, &c.	32	119-304	66, 67, 68	726-827
XXVI.	266-274	Natural Sines	44	488-517	65	725
XVII.	275-280	(A) and (B) for correcting Long. and finding Az.	—	—	—	—
XVIII.	281-284	(C) Azimuth for Lats. to 68°	—	—	—	—
XXIX.	285-291	Log. Rising	—	—	—	—
XXX.	292-308	☽ Parallax in Alt.	24	67-109	39	676-684
XXX.*	293-309	Correction of Auxiliary Angle A.	24	67-109	—	—
XXI.	310-318	{ Log. Hourly Angle (Inman, Log. Hav)	34	335-393	69	828-892
XXII.		{ (Raper, Log. Sin Sq.)				
XXIII.	319, 320	Logs. for reducing ☉ Dec., R. A., &c. to any Greenwich Date	—	—	—	—

NORIE ED. 1896			INMAN ED. '92		RAPER ED. '98	
Table	Page	Subject	Table	Page	Table	Page
XXXIV.	321-336	Proportional Logs.	42	467-486	74	909-923
XXXV.	337-339	To correct App. Lunar Dist., for Par. and Ref.	—	—	53, 54, 55	693
XXXVI.	340-362	Versines (Natural)	36	423-461	—	—
XXXVII.	362	Retardation	31	118	24	659
XXXVIII.	362	Acceleration	30	118	23	659
XXXIX.	363-371	Logarithmic Difference	—	—	73	900-908
XL.	371	Corr. of Log. Diff. when ☉ is Observed	—	—	73	900-908
XLI.	371	Corr. of Log. Diff. when a star is observed	—	—	73	900-908
XLII.	372, 373	Amplitudes	37	462-465	59, 59A	696, 697
XLIII.	374-375	Time Amplitudes	37	462-465	26	661-663
XLIV.	376-381	To find A. T. Of principal stars passing Meridian	—	—	27, 27A	664, 665
XLV.	382, 383	To find when celestial Object is on Prime Vertical	27 (Sun)	113, 114	29	665-670
XLVI.	384, 385	To find Alt. Of celestial Object when on Prime Vertical	28 (Sun)	114, 115	29	666-670
XLVII.	386-390	Logs. for finding corr. δ R. A. and Dec. for any Greenwich Date	—	—	22	657, 658
XLVIII.	391	Parallax in Alt. for Planets	20	62	45	686
XLIX.	391	To correct Log Diff. when a Planet is Observed	—	—	73	900-908
L.	392	To correct auxiliary angle A when a Planet is Observed	40	466	—	—
LI.	392	To reduce E. T. to any Greenwich Date	—	—	—	—
LII.	393	Logs. for computing the Equation of Equal Alts.	—	—	72	899
LIII.	394, 395	For converting foreign measures	46	519	37	674
LIV.	396	For finding exact M. T. G. corresponding to True Lunar Dist.	43	487	57	695
LV.	396	To reduce δ H. P. and S. D. to any Greenwich Date	—	—	—	—
LV.A	396	Corr. of δ Equatorial Par. for figure of Earth	—	—	—	—
LVI.	397-457	Principal Ports, Harbours, Headlands, &c., &c.	50	522-548	10	540-1634
LVII.	458-477	Time of H. W. at P. and C. and Spring Rise	—	—	—	—

INMAN ED. 1892			RAPER ED. '98	
Table	Page	Subject	Table	Page
1	1	Points Of Compass, &c.	—	—
2	1	Length of a degree of Long. in diff. Lats.	—	—
4	39	For converting Departure into Diff. Long.	3	522
5	40	For converting Diff. Long into Departure	4	523
6	41	For correcting Mid. Latitude	—	—
8	51	Distance Of Objects seen at sea	8	539
11	52	Position by two Bearings and Distance run	7	538
15	55	Symbols and Abbreviations used in Nautical Astronomy	—	—
20A	62 ^a to 64 ^a	Reduction to the Meridian	47, 48, 49, 50	688-691
20B	65 ^a	Length Of a degree in Lat. and Long.	70	893-896
20C	65 ^a	True Bearing of Pole Star	—	—
25	110-111	Johnson's Tables	—	—
33	305-334	$\frac{1}{2}$ Log. Haversines	—	—
38	466	Reduction Of Latitude	52	693
39	466	Reduction of S. D. on account Of Ref.	—	—
41	466	Correction Of auxiliary angle A for Bar. and Therm.	—	—
45	518	Corresponding Thermometer Scales	36	674
47	519	Astronomical data	—	—
48	520	Abbreviations in Admiralty Charts	—	924
49	520-521	Secondary Meridians	—	392-395
51	549-553	Distance Tables	12	635-643

RAPER ED. 1898

Table	Page	Subject
5	524-532	Spherical Traverse Table
9	539	No. of feet subtending 1' at different distances
11	634	Places at which docks or slips may be found and coal obtained
13	644	Time Signals
14	646	Epacts
15	646	Semimenstrual Inequality
16	646	Approximate Rise and Fall of Tides
21A	655-656	Logs. for reducing daily variations
25	660	For finding the Equation of Second Differences
40	685	Corresponding H. P. and S.-D. of MOON
43	686	Correction for reducing Tr. Alt. to App. Alt. of Sun or Star
44	686	Correction for reducing Tr. Alt. to App. Alt. of MOON
46	687	Azimuth and corresponding change of Alt. in 1 minute of time
56	694	For computing the MOON'S Second Corr. of Distance
58	695	Error of Ship's place due to 1' error in Lunar Distance
64A	724	Spheroidal Tables
71	897-898	Logs. for computing Corr. of Lat. by account

NOTES ON THE TABLES¹

It will be seen that Norie, Inman, and Raper all contain the Tables essential to the work of the Navigator. But some Tables are more convenient than others. For example, Norie's Log. Horary Angle Table corresponds to Inman's Log. Haversine Table and to Raper's Log. Sine Square Table, but the two latter are more convenient than the Log. Horary Angle of Norie for two reasons. The first is that while Inman and Raper each give a complete Table, Norie, for some reason known best to himself, limits the Horary Angle to 8 hours, and consequently it might very well happen that a bright star, such as Vega or Capella, might be rendered useless for finding Time if the observer was ignorant of other methods than Norie's for calculating the Hour Angle. And the second reason is that Norie, unfortunately, does not give the arc corresponding to Time in his Horary Table. The three Tables, though bearing different names, deal with the same thing, for the Log. Horary Angle is really a Log. Haversine; and Log. Haversine of any angle is the Log. Sine Square of half the same angle.

¹ Since the above was written a new and much improved edition of Norie's Tables, containing a complete Haversine Table, has been issued.



THIS PAGE IS LOCKED TO FREE MEMBERS

Purchase full membership to immediately unlock this page

DELVE INTO FANTASY, MAGIC, MYTHOLOGY & FOLKLORE

Forgotten Books'
Full Membership gives
access to 797,885 ancient
and modern, fiction and
non-fiction books.

Continue

*Fair usage policy applies

18000. It would be mere waste of time and space to make two sums of it, thus :

$$\begin{array}{r}
 1234 \\
 5678 \\
 9011 \\
 1213 \\
 \hline
 17136
 \end{array}
 \qquad
 \begin{array}{r}
 18000 \\
 17136 \\
 \hline
 864
 \end{array}$$

So you would write it as one sum, thus :

$$\begin{array}{r}
 1234 \\
 5678 \\
 9011 \\
 1213 \\
 \hline
 17136 \\
 18000 \\
 \hline
 864
 \end{array}$$

2nd. Under ordinary circumstances of multiplication by Logs. one would put the numbers, or angles, or time on the left, the Logs. equal to them on the right, and the number, angle, or time equal to the resultant Log. to the right of it, thus :

$$\begin{array}{l}
 123 \text{ Log.} = 2.089905 \\
 456 \text{ Log.} = 2.658965 \\
 \hline
 \text{Log. } 4.748870 = 56090 \text{ (Nat. No.)}
 \end{array}$$

But the exigencies of space, and general convenience frequently render it necessary to put the answer also on the left, and the above sum would be written thus :

$$\begin{array}{l}
 123 \text{ Log.} = 2.089905 \\
 456 \text{ Log.} = 2.658965 \\
 \hline
 \text{(Nat. No.) } 56090 = \text{Log. } 4.748870
 \end{array}$$

Proportion or Rule of Three

As 'time' and 'arc' are mentioned in the following examples, it is well to state that time is counted in hours, minutes, seconds (h. m. s.), and arc in degrees, minutes, seconds ($^{\circ}$ ' "). There are sixty seconds of time or of arc

in a minute, sixty minutes of time in an hour, sixty minutes of arc in a degree.

A simple proportion takes the following form : As 2 is to 4 so is 3 to 6, or substituting the abbreviations, as $2 : 4 :: 3 : 6$.

All simple proportions consist of four parts or terms. In this case these terms are 2, 4, 3 and 6. Of these 2 and 6 are called the 'extremes,' and 4 and 3 are called the 'means.'

The fact upon which the solution of problems in proportion rests is, that the product of the 'means' is equal to the product of the 'extremes.'

For instance, in the above proportion, 4 and 3 are the 'means,' 2 and 6 the 'extremes.' And 4 multiplied by 3 equals 2 multiplied by 6. $4 \times 3 = 12$ and $2 \times 6 = 12$. This form of simple proportion you will not have much occasion to use ; but you will have to use simple proportion to find an unknown fourth term from three known terms. If you have any three terms of a proportion you can find the fourth term by the following rules :

(1) If two 'means' and one 'extreme' are known, the product of the 'means' divided by the known 'extreme,' gives the other 'extreme.'

(2) If two 'extremes' and one 'mean' are known, the product of the two 'extremes' divided by the known 'mean' gives the other 'mean.'

This is easy enough. You must remember, however, that the first and second terms in a proportion must be of the same nature, that is, they must be multiples of the same quantity or measure, and that the fourth term will be of the same nature as the third. Thus, suppose you were given the following proportion, x representing the 'extreme' you want to find :

$$\text{As } 1 \text{ h. } 10 \text{ m.} : 18 \text{ m.} :: 12^\circ 48' : x.$$

Before multiplying the two means together you must make the first and second terms of the same nature, that is, multiples of the same quantity, which in this case can be easily done by turning 1 h. 10 m. into minutes of time.

Also, to avoid the trouble of compound multiplication, it is best to reduce $12^{\circ} 48'$ into minutes of arc.

Now to work out the problem :—

$$\begin{array}{r}
 \text{As } 1^{\text{h}} 10^{\text{m}} : 18^{\text{m}} :: 12^{\circ} 48' : x \\
 \quad \quad \quad \underline{60} \qquad \qquad \quad \quad \quad \underline{60} \\
 \text{As } 70^{\text{m}} \qquad : 18^{\text{m}} :: \underline{768'} : x \\
 \qquad \qquad \qquad \qquad \qquad \quad \quad \quad \underline{18} \\
 \qquad \qquad \qquad \qquad \qquad \quad \quad \quad 6144 \\
 \qquad \qquad \qquad \qquad \qquad \quad \quad \quad \underline{768} \\
 \qquad \qquad \qquad \qquad \qquad \quad \quad \quad 70 \) \ 13824' \ (197' 29'' \text{ or } 3^{\circ} 17' 29'' \\
 \qquad \qquad \qquad \qquad \qquad \quad \quad \quad \underline{70} \\
 \qquad \qquad \qquad \qquad \qquad \quad \quad \quad 682 \\
 \qquad \qquad \qquad \qquad \qquad \quad \quad \quad \underline{630} \\
 \qquad \qquad \qquad \qquad \qquad \quad \quad \quad 524 \\
 \qquad \qquad \qquad \qquad \qquad \quad \quad \quad \underline{490} \\
 \qquad \qquad \qquad \qquad \qquad \quad \quad \quad 34' \\
 \qquad \qquad \qquad \qquad \qquad \quad \quad \quad \underline{60} \\
 \qquad \qquad \qquad \qquad \qquad \quad \quad \quad 70 \) \ 2040'' \ (29'' \\
 \qquad \qquad \qquad \qquad \qquad \quad \quad \quad \underline{140} \\
 \qquad \qquad \qquad \qquad \qquad \quad \quad \quad 640 \\
 \qquad \qquad \qquad \qquad \qquad \quad \quad \quad \underline{630} \\
 \qquad \qquad \qquad \qquad \qquad \quad \quad \quad 10
 \end{array}$$

Here we multiply the two 'means' together, and the product is 13824; this we divide by the known 'extreme,' 70 m. which gives us as the other extreme 197' and $\frac{6}{7}\frac{4}{10}$ over. Turn the 34' into seconds, and divide by 70, and we have 197' 29''; divide the 197' by 60 to turn them into degrees, and we get $3^{\circ} 17' 29''$. Remember always that what you get in the fourth term is of the same nature as the third term, whether it be degrees, miles, feet, tons, or anything else.

You will find later on the utility of this rule in determining, among other things, the amount a heavenly body will rise or fall in a certain time if you know how

much it has risen or fallen in a given time. For example, suppose at 9 h. 18 m. 28 s. the Altitude of some heavenly body was $32^{\circ} 18' 20''$, and that at 9 h. 35 m. 30 s. the Altitude of the same body was $35^{\circ} 14' 18''$, and that you wanted to know what its Altitude was at 9 h. 22 m. 14 s. How would you proceed? In the following way.

First find out how much the body rose in the first interval.

Time	Altitude
At 9 ^h 18 ^m 28 ^s	32° 18' 20''
At 9 35 30	35 14 18
Therefore in 0 17 2	it rose 2 55 58

Next you must find how much it would rise in the second interval. What is the second interval?

9 ^h 22 ^m 14 ^s
9 18 28

0 3 46 is the second interval.

Now you have three known terms, 17 m. 2 s. (the first interval), 3 m. 46 s. (the second interval), and $2^{\circ} 55' 58''$ (the increase of Altitude in the first interval), and require to find the fourth unknown term.

As 17 ^m 2 ^s : 3 ^m 46 ^s :: 2° 55' 58'' : x
60 60 60

1022 ^s 226 ^s 175'
60

10558 secs. of arc.
226

63348
21116
21116

1022) 2336108 (2334 $\frac{3}{4}$ secs. of arc. or 38' 55'' (nearly)
2044

3421
3066

3550
3066

4848
4088

760

Therefore $38' 55''$ is the amount the body will rise in 3 m. 46 s., and this amount added to $32^\circ 18' 20''$, the known Altitude at 9 h. 18 m. 28 s., gives the Altitude at the time required, namely at 9 h. 22 m. 14 s.

Time	Altitude
At 9 ^h 18 ^m 28 ^s the Altitude of the body was	$32^\circ 18' 20''$
In <u>3 46</u> it rose	<u>38 55</u>
Therefore at 9 22 14 the Altitude was	$32 57 15$

This is a long sum, but by using proportional Logs., as will hereafter be explained, the work is very much shortened.

Decimal Fractions

A vulgar fraction consists of two parts, the numerator and the denominator ; the numerator is above the line and the denominator below it. The denominator expresses the value of each equal part into which any unit is divided, and the numerator expresses the number of such parts. Thus $\frac{3}{4}$ is a vulgar fraction ; the numerator is 3 and the denominator 4. The denominator shows that each part is one-fourth of the whole, and the numerator shows that there are three such parts. Take another fraction, $\frac{3}{5}$ for example. Here the unit is divided into 5 equal parts—the denominator shows this ; and there are 3 of these parts, as indicated by the numerator ; the value of the fraction is therefore three-fifths.

The denominator of a vulgar fraction may be any number you like ; the denominator of a decimal fraction must be ten or some multiple of ten, and therein lies the difference between a vulgar and a decimal fraction. In decimal fractions the denominator is expressed by a dot, thus: $\cdot 1$ is one-tenth. The figures after the dot are called decimal places. The number of decimal places

shows the value of the denominator ; thus $\cdot 1$ is $\frac{1}{10}$, $\cdot 01$ is $\frac{1}{100}$, $\cdot 001$ is $\frac{1}{1000}$, $\cdot 12$ is $\frac{12}{100}$, $\cdot 123$ is $\frac{123}{1000}$, and so on.

You can always, of course, express a decimal fraction as a vulgar fraction exactly, but you cannot always express a vulgar fraction as a decimal fraction exactly. The decimal equivalent of a vulgar fraction is often self-evident ; thus $\frac{1}{2}$ is evidently the same thing as $\frac{5}{10}$, and $\frac{5}{10}$ is written decimally as $\cdot 5$; and even in those cases in which the conversion is not self-evident, the process of turning vulgar fractions into decimals is very simple. All you have to do is to divide the numerator by the denominator—this will give you the decimal exactly if the vulgar fraction can be turned exactly into a decimal fraction, and if it cannot the process will give you the decimal very nearly. Thus $\frac{3}{10}$ is a vulgar fraction, and can be expressed exactly as a decimal fraction thus :
$$10 \overline{) 3 \cdot 0} \\ \underline{ 3} \\ 0$$

Some vulgar fractions, as for instance $\frac{1}{3}$, cannot be expressed exactly as a decimal fraction.

$$3 \overline{) 1 \cdot 0} (\cdot 333 \text{ etc. } ad \text{ infinitum.} \\ \underline{ 9} \\ 10 \\ \underline{ 9} \\ 10$$

Such a decimal fraction is called a recurring decimal, and is written thus, $\dot{3}$, with a dot over the 3.

In turning vulgar fractions into decimals, you may arrive at a decimal containing three or more, and perhaps a lot more figures. Console yourself by the reflection that, for navigational purposes, one decimal place, or at any rate two decimal places, are good enough. Thus $\cdot 1234$ would be called $\cdot 12$ or probably $\cdot 1$. If the figure to the right of the second or of the first decimal place is 5, or bigger than 5, increase the second or first figure by one,

thus : $\cdot 126$ should be called $\cdot 13$, and $\cdot 36$ should be called $\cdot 4$, because in the first case $\cdot 13$ is nearer to the truth than $\cdot 12$, and in the second place $\cdot 4$ is nearer to the truth than $\cdot 3$.

The immense advantage of the decimal system is, that compound addition, subtraction, multiplication, and division are done away with. Its weakness is, that some fractions cannot be expressed absolutely by its means, but they can be expressed quite nearly enough for all navigational work. Decimals are wonderfully useful in navigation, as you will appreciate fully later on ; in fact, problems could not be worked without them.

Addition of Decimals

The quantities to be added together must be written down so that the decimal points are all in the same perpendicular line, under one another. Then proceed to add as in ordinary arithmetic, and place the decimal point in the sum in a line with and under the decimal points in the quantities added.

For example, add together $1\cdot 789$, $78\cdot 01$, $\cdot 026$, 10000 , $11\cdot 002$, and $100\cdot 01$.

$$\begin{array}{r}
 1\cdot 789 \\
 78\cdot 01 \\
 \cdot 026 \\
 10000\cdot \\
 11\cdot 002 \\
 100\cdot 01 \\
 \hline
 10190\cdot 837
 \end{array}$$

There you are. The 10190 , being a whole number, is to the left of the decimal point, and the fraction 837 is to the right of it.



THIS PAGE IS LOCKED TO FREE MEMBERS

Purchase full membership to immediately unlock this page

SAVE \$3,999,994

Did you know we sell
paperback books too?

To buy our entire catalog
in paperback would cost
over \$4,000,000

Access it all now for
\$8.99/month

*Fair usage policy applies

Continue

Here are a few examples, to which I would ask your closest attention :

(1) Multiply 18·5 by 19·2.

$$\begin{array}{r}
 18\cdot5 \\
 19\cdot2 \\
 \hline
 370 \\
 1665 \\
 185 \\
 \hline
 355\cdot20
 \end{array}$$

There is one decimal place in each of the two factors, 18·5 and 19·2, that is, two decimal places in all, so that you point off two decimal places from the right of the product, and the dot comes between the 2 and the 5. Of course, zeros on the right of a decimal without any digits to the right of them are of no value, but they must never be struck off a product till the decimal point has been placed.

(2) Multiply 1·042 by 198.

$$\begin{array}{r}
 1\cdot042 \\
 198 \\
 \hline
 8336 \\
 9378 \\
 1042 \\
 \hline
 206\cdot316
 \end{array}$$

Here there are three decimal places in 1·042, and none in 198. Therefore we point off three decimal places from the right in the product.

(3) Multiply 79·89 by ·0042.

$$\begin{array}{r}
 79\cdot89 \\
 \cdot0042 \\
 \hline
 15978 \\
 31956 \\
 \hline
 \cdot335538
 \end{array}$$

Here there are two decimal places in 79·89, and four in ·0042, therefore six decimal places are pointed off in the product.

(4) Multiply $\cdot 0045$ by 10 .

$$\begin{array}{r} \cdot 0045 \\ 10 \\ \hline \cdot 0450 \end{array}$$

Here we have altogether four decimal places to point off in the product 450 , and so a zero must be placed to the left of 450 to make up the number. Zeros required to make up the number of decimal places in a product must be placed to the *left* of the left-hand digit. Although the last zero is valueless, it must be counted when pointing off the product.

(5) Multiply $\cdot 0001$ by $\cdot 0002$.

$$\begin{array}{r} \cdot 0001 \\ \cdot 0002 \\ \hline \cdot 00000002 \end{array}$$

This is rather an extreme case. We have eight decimal places in the factors, and therefore we must add seven zeros to the left of the product 2 before we can place the decimal point.

(6) Multiply $79\cdot 89$ by $121\cdot 2$.

$$\begin{array}{r} 79\cdot 89 \\ 121\cdot 2 \\ \hline 15978 \\ 7989 \\ 15978 \\ 7989 \\ \hline 9682\cdot 668 \end{array}$$

Three decimal places in the factors, therefore three in the product.

In such a case as this, after the decimal place has been put in according to the rule, you can check the result by taking two simple numbers nearly equal to those in the question, and multiplying them in your head. Thus in this case, instead of $79\cdot 89$ take 80 , and instead of $121\cdot 2$ take 120 .

The product of 80 and 120 is 9600. This is sufficiently near to 9682.668 to show that the decimal point has been put in correctly. If you had made a mistake and put down 968.2668, you would have found it out.

So much for multiplication of decimals. You will have to do plenty of it in the course of your navigational studies, so I will pass on to

Division of Decimals

Division of decimal fractions is managed exactly in the same way as division in ordinary arithmetic. As in multiplication, the only difficulty consists in placing the decimal point correctly in the quotient. You must place in the *quotient* that number of decimal places which, added to the number of decimal places in the *divisor*, equals the number of decimal places in the *dividend*. It is really the same rule as in multiplication, because the product of the divisor and quotient is, of course, the dividend. Here are a few examples :

(1) Divide 4614.316 by 312.2.

$$\begin{array}{r}
 312.2 \) \ 4614.316 \ (\ 14.78 \\
 \underline{3122} \\
 14923 \\
 \underline{12488} \\
 24351 \\
 \underline{21854} \\
 24976 \\
 \underline{24976} \\
 0
 \end{array}$$

Here we have three decimal places in the dividend, and only one in the divisor. It is necessary to add two decimal places to those in the divisor to make them equal to the number of decimal places in the dividend ; you consequently have two in the quotient, and here it is, 14.78.

As a check on the result, notice that, roughly speaking, you are dividing 4600 by 300, so that 14 or 15 is evidently pretty near the answer.

(2) Divide $\cdot 702$ by $\cdot 009$.

$$\cdot 009 \overline{) \cdot 702} \quad (78$$

Now you have three decimal places in the dividend, and three in the divisor, therefore you want none in the quotient, and the answer is 78.

(3) Divide $\cdot 63675$ by $84\cdot 9$

$$\begin{array}{r} 84\cdot 9 \overline{) \cdot 63675} \quad (75 \\ \underline{5943} \\ 4245 \\ \underline{4245} \end{array}$$

Here are five decimal places in the dividend, and only one in the divisor, therefore there must be four in the quotient. But we have only two figures, and to make up the four necessary places two zeros must be put to the left of them, and then the decimal point. So the answer is $\cdot 0075$. As in the product of a multiplication sum, so in the quotient of a division sum, zeros to make up the number of decimal places required must be placed to the left of the left-hand digit.

Check.—If in doubt about the position of the decimal point, multiply $84\cdot 9$ by $\cdot 0075$, and the result $\cdot 63675$ shows the decimal point is correctly placed.

(4) Divide 5 by 250.

$$250 \overline{) 5\cdot 00} \quad (2$$

In this case, in order to make five divisible by 250, you must add two zeros after the decimal point, which makes no difference to the value of the dividend. Then you have two decimal places in the dividend, and none in the divisor; you must therefore have two in the quotient, and here you are, $\cdot 02$.

In all cases where the divisor will not go into the dividend, add zeros to the dividend, placing them to the right of the decimal point if there is no fraction, or to the right of the fraction if there is one. These zeros make no difference to the value of the dividend, but they count as decimal places when placing the decimal point in the quotient.

(5) Divide 1.7 by 50000.

$$\begin{array}{r} 50000 \) \ 1.70000 \ (\ 34 \\ \underline{150000} \\ 200000 \\ \underline{200000} \end{array}$$

Here there are five decimal places in the top line of the dividend, and we borrowed another in the third line, making six in all. But there are none in the divisor, so we must have six decimal places in the quotient, and four zeros must be placed to the left of the 34, and the answer is .000034.

(6) Divide 1 by .000001.

No decimal point in the dividend and six in the divisor. Add 6 zeros to the right of the 1 in the dividend, and divide out.

$$.000001 \) \ 1.000000 \ (\ 1000000$$

Reduction of Decimals

You must understand the reduction of decimal fractions. The subject naturally divides itself into two branches, the one dealing with reducing ordinary quantities into decimals, and the other with reducing decimals into ordinary quantities. Let us first deal with turning ordinary quantities into decimals.

Suppose you were asked to turn 10*l.* 12*s.* 6*d.* into pounds and decimals of a pound. The first step would be to find what decimal of a shilling sixpence is, and the

second to find what decimal of a pound the shillings and decimal of a shilling is. In expressing a penny as the decimal of a shilling, consider the penny as a vulgar fraction of a shilling; one penny is $\frac{1}{12}$ of a shilling; then turn the vulgar fraction into a decimal by dividing the numerator by the denominator as has been already explained.

First then turn the 6 pence into decimals of a shilling by dividing them by 12, thus :

$$\begin{array}{r} 12 \overline{) 6 \cdot 0} \\ \underline{ 5} \\ \cdot 5 \end{array}$$

Sixpence is $\cdot 5$ of a shilling, and we now have 10 pounds and 12 \cdot 5 shillings. Next turn the 12 \cdot 5 shillings into decimals of a pound by dividing by 20.

$$\begin{array}{r} 20 \overline{) 12 \cdot 50} \quad (\cdot 625 \\ \underline{120} \\ 50 \\ \underline{40} \\ 100 \\ \underline{100} \end{array}$$

Here we have three decimal places in the dividend, having borrowed a zero in addition to the two decimal places in the first line; and, as there are no decimal places in the divisor, we must have three in the quotient, which is therefore $\cdot 625$. 12 \cdot 5 of a shilling is therefore $\cdot 625$ of a pound, and tacking this on to the pounds, we find that 10*l.* 12*s.* 6*d.* = 10 \cdot 625*l.*

Now suppose you want to reverse the process, and turning decimals into ordinary quantities, require to find the value of 10 \cdot 625*l.* You must first turn the decimals of a pound into shillings by multiplying by 20, thus :

$$\begin{array}{r} \cdot 625 \\ \underline{20} \\ 12 \cdot 500 \end{array}$$

Therefore, $\cdot 625$ of a pound $\times 20 = 12 \cdot 5$ shillings. Then

turn the decimals of a shilling into pence by multiplying by 12, thus :

$$\begin{array}{r} .5 \\ 12 \\ \hline 6.0 \end{array}$$

Therefore, $\cdot 5$ of a shilling $\times 12 = 6.0$ pence. And you find that $10.625l. = 10l. 12s. 6d.$

It is not improbable that you will spend more time at sea in dealing with arc and time than with money, unless you happen to hit upon a treasure island, so I append a few examples here.

(1) Turn $37^{\circ} 48' 00''$ into degrees and decimals of a degree.

In one degree there are $60'$. Therefore, divide $48'$ by 60 to bring it into decimals of a degree. $48' \div 60 = \cdot 8$ of a degree. The answer, therefore, is 37.8° .

To reverse the above and express 37.8° in degrees and minutes. To turn $\cdot 8$ of a degree into minutes you must multiply it by 60 . $\cdot 8^{\circ} \times 60 = 48.0'$, therefore, $37.8^{\circ} = 37^{\circ} 48'$.

(2) Find what decimal fraction of a day 14 hours 18 minutes is.

There are 60 minutes in an hour, therefore, to turn 18 minutes into decimals of an hour, divide by 60 . $18 \div 60 = \cdot 3$. Therefore 18 minutes $= \cdot 3$ of an hour.

Now to find what decimal fraction of a day 14.3 hours is. There are 24 hours in a day, therefore divide 14.3 by 24 .

$$\begin{array}{r} 24 \) \ 14.3 \ (\ .5958 \\ \underline{120} \\ 230 \\ \underline{216} \\ 140 \\ \underline{120} \\ 200 \\ \underline{192} \\ 8 \end{array}$$



THIS PAGE IS LOCKED TO FREE MEMBERS

Purchase full membership to immediately unlock this page

DELVE INTO FANTASY, MAGIC, MYTHOLOGY & FOLKLORE

Forgotten Books'
Full Membership gives
access to 797,885 ancient
and modern, fiction and
non-fiction books.

Continue

*Fair usage policy applies

Thus, suppose you want to know what decimal fraction of an hour ten minutes is. You proceed thus :

$$\begin{array}{r} 6 \overline{) 10000} \\ \cdot 1666 \text{ \&c. \&c.} \end{array}$$

is the correct answer. Well, $\cdot 17$ is near enough for you. Remember always to add 1 to the last digit if the next one is 5 or more than 5. Thus $\cdot 166$ must be called $\cdot 17$, because $\cdot 17$ is nearer the truth than $\cdot 16$.

It is generally easy to place the decimal point, even in division, by using a little common sense. If the number to the left of the decimal point in the divisor is less than the number to the left of the decimal point in the dividend, there must be at least one whole number in the quotient. If, on the contrary, the whole number in the dividend is less than that in the divisor, the decimal point must come first in the quotient.

When the decimal place has been put in according to the rule, look at the result and see that it is roughly about the right amount.

CHAPTER II

LOGARITHMS

LOGARITHMS are the invention of a most talented man, John Napier, of Merchistoun. Logarithms, or, as they are called for convenience sake, Logs., enable us to substitute addition for multiplication, and subtraction for division—an immense boon to the mariner. If the wretched sailor had to multiply and divide the long rows of figures and the numerous angles which abound in great profusion in his calculations, he would not be done working one set of sights before it was time to begin working another set, and every sea-going ship would have to be fitted with a private lunatic asylum. But with the help of Logs., Navigation becomes easy, for addition and subtraction are simple operations, which do not consume much time, or cause any great amount of chafe of the brain.

Every ‘natural’ number, that is to say every number in the natural ordinary sense of the word, has a Log. ; and *per contra* every Log. has a natural number. If you have to multiply two numbers or two dozen numbers together, or if you have to divide two numbers or two dozen numbers, all you have to do is to find the appropriate Logs., and add or subtract them ; the result will be the Log. of a natural number, which is the result of the multiplication or division of the numbers. What you have got to learn therefore is : 1st, how to find the Log. of any natural

number; 2nd, how to find the natural number of any Log.; 3rd, how to add Logs. together; 4th, how to subtract Logs. from each other.

A Log. generally consists of two parts, a whole number containing one or more digits—this is called the ‘Characteristic’ or ‘Index’—and a number of digits separated from the characteristic by a decimal point; this decimal part of the Log. is called the ‘Mantissa.’ Though ‘Characteristic’ is the proper term to employ, ‘Index’ is more generally used, and for the future I shall speak of the ‘Index.’ For instance, take any Log., say 2·944483: 2 is the Index, and 944483 is the Mantissa.

Natural numbers and Logs. are tabulated in Table XXIV. headed ‘Logarithms of Numbers.’ In the left-hand column, headed ‘No.,’ you will find natural numbers from 100 on page 137, to 999 on page 151. Zeros in natural numbers make no difference to the Mantissa of a Log. For instance, the Mantissa or decimal part of the Log. of 1, of 10, of 100, of 1000, and so on, is the same; the Log. of 15, of 150, of 1500, &c. is the same; the Log. of 172, of 1720, of 17200, &c. is the same. Therefore you need take no notice of that portion of ‘Logarithms of Numbers’ from 1 to 100 contained on page 136. It is useless and confusing, so leave it alone.

To find the Log. of a natural number.—Remember that the Table gives you the *Mantissa* only, and that having first got that you must afterwards find the Index. Suppose you require the Log. of a single number, say of 2. Look for 200 in the left-hand column headed ‘No.,’ and to the right of it, in column headed ‘0,’ you will find 301030; that is the Mantissa of 2. Suppose you require the Log. of a number consisting of two figures, say 23. Look for 230 in the ‘No.’ column, and in column ‘0’ you will find 361728; that is the Mantissa of 23. Suppose

you want the Log. of a number containing three figures, say 234. Look for 234 in the 'No.' column, and in the '0' column you will find 369216 ; that is the Mantissa of 234. Suppose you want the Log. of a number containing four figures, say 2341. Look for 234 in the 'No.' column, and in a line with it, in the column headed '1,' you will find 369401 ; that is the Mantissa of 2341. If you wanted the Log. of 2342 you would find the Mantissa in the '2' column, by following along from 234 in the 'No.' column. If you wanted the Log. of 2343, the Mantissa will be in the '3' column. If you wanted the Log. of 2344, the Mantissa will be in the '4' column, and so on to 2349. Now to find the Index.

The Index is always one *less* than the number of figures in the natural number. If the natural number consists of one figure the Index will be zero (0) ; if the number has two figures the Index will be 1 ; if the number has three figures the Index will be 2, and so on. Consequently, in the case of the natural number 2 which I have used above, as 2 consists of one figure the Index is 0. The Mantissa of 2 is 301030, therefore the Log. of 2 is 0.301030. It is useless expressing the zero, and you would write the Log. of 2 as .301030.

23 contains two figures, the Index is therefore 1. The Mantissa of 23 is 361728, therefore the Log. of 23 is 1.361728. The Mantissa of 234 is 369216, and the Log. of 234 is 2.369216, because 234 contains three figures, and the Index consequently is 2. The Mantissa of 2341 is 369401, and the Log. of 2341 is 3.369401, because 2341 contains four figures.

To find the natural numbers of Logs.—Look out the Mantissa of the Log. in the table in the columns '0,' '1,' '2,' &c. &c., and, wherever it may be, you will find its natural number in the same line with it in the 'No.'

column. The value of the *Index* will show you how many figures there are in the natural number. You know that the Index of a Log. is always one *less* than the natural number of the Log., and *per contra* the natural number must always be one *more* than the Index of its Log. Consequently, if the Index is 0, the natural number will consist of one figure. If the Index is 1, the natural number will contain two figures. If the Index is 2, the natural number will contain three figures, and so on and so on. If the natural number belonging to the Mantissa of a Log. does not contain one figure more than the Index of the Log. you must add zeros till it does. If the Mantissa of a Log. gives you more figures in the natural number than there ought to be according to the Index of the Log., then the natural number contains a decimal fraction, and you must put a dot after the proper number of figures as determined by the Index. Take any Log., say $\cdot 698970$; you want to know its natural number. Look for 698970 in the Table in one of the columns headed from '0' to '9.' You will find 698970 in column '0' on p. 143, and alongside to the left in the 'No' column you will see 500. Your Log. was $\cdot 698970$. It had zero in the Index, therefore its natural number must consist of *one* figure: therefore the natural number is $5\cdot 00$, or 5.

Suppose the Log. to have been $1\cdot 698970$. 1 in the Index shows there must be two figures in the natural number, therefore the natural number is $50\cdot 0$, or 50. If the Log. had been $2\cdot 698970$ the natural number would be 500. If the Log. had been $3\cdot 698970$, 3 in the Index requires four figures in the number, but there are only three in 500. You must therefore add $\text{\textcircled{x}}$ zero, and make it 5000, and that is the natural number of $3\cdot 698970$. And so on.

Take another Log., say $2\cdot 662663$. Look for the

Mantissa 662663 in the Table—you will find it in column 9, p. 142—and alongside to the left, in the ‘No.’ column, you will see 459. The Mantissa being in the 9 column, of course 9 must be added to the number in the ‘No.’ column, so 4599 is the natural number. The Index of the Log. is 2, and there must be three figures in the natural number; therefore cut off three figures by a decimal point, and you have the natural number 459.9. If the Index had been 3, the number would have been 4599. If the Index had been 1, the natural number would have been 45.99. If the Index had been 0, the natural number would have been 4.599.

Now, having seen how to find the Log. of a number and the number of a Log., let us consider multiplication and division.

Multiplication and Division by Logs.—To multiply two numbers, find the Log. of each number, add them together and find the natural number of the resultant Log. To divide one number by another. Take the Log. of the Divisor from the Log. of the Dividend, and find the natural number of the resulting Log. For instance, $4 \times 2 = 8$ by ordinary multiplication; $4 \div 2 = 2$ by ordinary division; now work the same sum by Logs. The Log. of 4 is .602060. The Log. of 2 is .301030. Add them together.

$$\begin{array}{r} .602060 \\ .301030 \\ \hline .903090 \end{array}$$

The natural number of 903090 is 800. Zero in the Index gives one figure in the number, therefore the number is 8.00, or 8.

Subtract .301030 from .602060.

$$\begin{array}{r} .602060 \\ .301030 \\ \hline .301030 \end{array}$$

The natural number of 301030 is 200, and the Index being zero, it is 2.00, or 2.

Suppose you wish to multiply 8197 by 5329, and also to divide 8197 by 5329. The Mantissa of 8197 is 913655, and the Index is 3, because there are four figures in the number, therefore the Log. is 3.913655. The Mantissa of 5329 is 726646. The Log. will be 3.726646, because there are four figures in the number.

$$\begin{array}{r} 3.913655 \\ 3.726646 \\ \hline 7.640301 \end{array}$$

You will not find the exact number 640301 in the Tables, but you will find something near enough to it, namely, 640283 in the '8' column on p. 142, and that will give you 436 in the 'No.' column; the natural number, therefore, is 4368. 7 in the Index requires eight figures in the natural number, but you have only four, and you must therefore add four zeros; and the natural number is 43680000, Therefore $8197 \times 5329 = 43680000$ nearly. Now for the division.

$$\begin{array}{r} 3.913655 \\ 3.726646 \\ \hline 0.187009 \end{array}$$

You will not find 187009 in the Tables, but you will find something near enough, namely, 186956 in the '8' column on page 137, with the number 153 in the 'No.' column. The natural number, therefore, is 1538. Zero in the Index gives one figure in the number, therefore the natural number is 1.538. Therefore $8197 \div 5329 = 1.538$, or $1\frac{1}{2}$ very nearly.

Whenever you can check the answers easily as far as number of figures or position of the decimal point goes, do so. For example, as in the last case you were multiplying 8000 by 5000 roughly speaking, the answer would be 40000000. This agrees with 43680000 sufficiently to



THIS PAGE IS LOCKED TO FREE MEMBERS

Purchase full membership to immediately unlock this page

SAVE \$3,999,994

Did you know we sell
paperback books too?

To buy our entire catalog
in paperback would cost
over \$4,000,000

Access it all now for
\$8.99/month

*Fair usage policy applies

Continue

to the Log. of the first four numbers already found, and the result is the Log. required. *Remember that a zero counts as a figure.* For instance, suppose you want the Log. of 123456. Tick off the first four figures thus, 1234'56, and find the Log., or, to be accurate, the Mantissa of the Log. of 1234. It is 091315. In the same line in the 'Diff.' column you will find 352. Multiply 352 by 56 (the remaining figures in your number).

$$\begin{array}{r} 352 \\ 56 \\ \hline 2112 \\ 1760 \\ \hline 19712 \end{array}$$

From the product 19712 cut off from the right as many figures as the *multiplier* contained, namely two. That leaves 197 to be added to the Log. of the first four figures.

$$\begin{array}{r} 091315 \\ 197 \\ \hline 091512 \end{array}$$

091512 is the Log. required.

The reason for this process is very simple. The numbers in the column 'Diff.' are the differences between the Logs. of two consecutive numbers. The difference between the two numbers is 100; the difference between the number whose Log. you have taken out and the number whose Log. you require is 56. The difference in the 'Diff.' column between the Mantissa you have taken out and the next larger is 352. It is a simple sum in proportion, as $100 : 56 :: 352 : x$.

Now for the Index. You must count all the figures in your number. There are six figures, therefore the Index is 5. Therefore the Log. of 123456 is 5.091512.

In all questions of this kind it is advisable after the answer has been obtained to check it by seeing that the Log. found lies between the Log. of the right two numbers. The Log. of 123456 should lie between Log.

1234 and Log. 1235 ; and since 091512 is between 091315 and 091667 it is evident that no mistake has been made.

To find the natural number corresponding to a Log. to more than four figures.—Now suppose you are occupied in the reverse process, and having the Log. 5·091512 you want to find its natural number. Look for the Log. in the Tables. You won't find 091512 anywhere. In such a case you must take out the natural number to four figures, for the nearest *less* Log., and write it down. Then find the difference between this nearest less Log. and your Log. ; divide this difference by the figure in the 'Diff.' column, adding as many zeros to the difference as may be necessary, and add the quotient to the first four figures of the natural number already taken out and written down. You want the natural number of 5·091512. The nearest less Mantissa in the Table is ·091315, of which the natural number is 1234 ; write that down. Next find the difference between 091315 (the nearest Log.) and 091512 (your Log.).

$$\begin{array}{r} 091512 \\ 091315 \\ \hline 197 \end{array}$$

The difference is 197. In a line with 091315, and in the 'Diff.' column, you will find 352. You have got to divide 197 by 352, adding zeros to 197.

$$\begin{array}{r} 352 \) \ 1970 \ (\ 56 \ \text{nearly} \\ \underline{1760} \\ 2100 \\ \underline{2112} \end{array}$$

56 is to be tacked on to the four figures already taken out, namely 1234, and the natural number required is therefore 123456. You will note that the division of 197 by 352 did not come out exactly, but the product, 56, was much more nearly correct than 55 ; and as you knew by the Index that you only wanted two more additional figures,

it was useless proceeding further. Had you proceeded further, the sum would have worked out thus :

$$\begin{array}{r}
 352 \) \ 1970 \ (\ 559 \\
 \underline{1760} \\
 2100 \\
 \underline{1760} \\
 3400 \\
 \underline{3168} \\
 232
 \end{array}$$

This would have given you 559 to tack on to 1234 already found, and your natural number would be 1234559. But as the Index of the Log. was 5, there could only be six whole figures in the natural number, which would therefore be 123455.9. All you wanted was a number consisting of six figures, and 123456 is nearer than 123455 with a useless $\frac{9}{10}$.

Here are some examples :

Find the Log. of 798412.

$$\begin{array}{r}
 \text{Mantissa of 7984} = 897297 \quad \text{Diff.} = 55 \\
 \text{Parts for 12} = \quad \quad \quad 7 \quad \quad \quad \underline{12} \\
 \text{Log. of 798412} = 5.897304 \quad \quad \quad 660 = 7 \text{ nearly.}
 \end{array}$$

Find the Log. of 548208.

$$\begin{array}{r}
 \text{Mantissa of 5482} = 738939 \quad \text{Diff.} = 79 \\
 \text{Parts for 08} = \quad \quad \quad 6 \quad \quad \quad \underline{08} \\
 \text{Log. of 548208} = 5.738945 \quad \quad \quad 632
 \end{array}$$

Find the Log. of 400006.

$$\begin{array}{r}
 \text{Mantissa of 4000} = 602060 \quad \text{Diff.} = 108 \\
 \text{Parts for 06} = \quad \quad \quad 6 \quad \quad \quad \underline{06} \\
 \text{Log. of 400006} = 5.602066 \quad \quad \quad 648
 \end{array}$$

Find the number whose Log. is 4.902030.

$$\begin{array}{r}
 4.902030 \\
 \text{Nat. No. 7980} \quad \underline{902003} \text{ Nearest Log.} \\
 \text{Diff. } 54 \) \ 270 \ (\ 5 \\
 \quad \quad \quad 270
 \end{array}$$

The number is 79805.

Find the number whose Log. is 6.012839.

$$\begin{array}{r}
 6.012839 \\
 \text{Nat. No. 1030} \quad \underline{012837} \text{ Nearest Log.} \\
 \text{Diff. } 420 \) \ 2000 \ (\ 005 \text{ very nearly} \\
 \quad \quad \quad 2100
 \end{array}$$

The number is 1030005 very nearly.

Find the number whose Log. is 5·639486.

$$\text{Log. } 4360 = \frac{5\cdot639486}{\underline{639486}}$$

The number is 436000.

Hitherto we have considered and used numbers composed entirely of integers or whole numbers, but you may require the Log. of a number consisting partly of integers and partly of decimals, such as 2·3, or composed entirely of decimals, such as ·23.

Logs. of numbers composed of integers and decimals.—Use the whole of the number, *decimals* and all, to find the Mantissa of the Log. Thus to find the Log. of 1·2 :—Look out the Mantissa of 12, which, as you know, is the same as that of 120; it is 079181. Now for the Index. You have only one integer, and therefore the Index is zero and the Log. of 1·2 is ·079181. In the case of numbers composed of integers and decimals, the Index is always either 0 or a *positive* or *plus* quantity.

In the case of numbers consisting entirely of decimals, the Index will be a *negative* or *minus* quantity. As one integer gives zero in the Index, it is obvious that no integer will give an Index one less than zero, or minus 1. The Index of a decimal, say ·2 or ·23 or ·234 and so on, is -1 , and the Index of ·02, or ·023, or ·0234, and so on, is -2 , and the Index of ·002, or ·0023, or ·00234 is -3 , &c. &c. &c. But, as in adding and subtracting, it would be awfully confusing to mix up minus and plus quantities, the arithmetical complement (ar. co.) of the minus Indices is always used. $10-1=9$; $10-2=8$; $10-3=7$, and so on; therefore 9 is the arithmetical complement (ar. co.) of 1; 8 is the ar. co. of 2; 7 is the ar. co. of 3, and so on; and 9, 8, 7, &c. &c. in the Index are always used instead of -1 , -2 , -3 , &c. &c.

Log. of a decimal fraction.—Suppose you want the

Log. of a decimal fraction. Very well. Look for the figures in the decimal fraction in the Table in the same way as if they were integers, and take out the Mantissa. Remember that zeros have no value in finding the Mantissa, unless they occur between digits. The Mantissa of $\cdot 2$, or $\cdot 20$, or $\cdot 200$ is the same, namely 301030. The Mantissa of $\cdot 23$, of $\cdot 023$, or $\cdot 0023$ &c. is the same, namely 361728. But introduce a zero or zeros among the digits and the Mantissas are by no means the same; the Mantissa of $\cdot 203$ is not 361728 but 307496, and the Mantissa of $\cdot 2003$ is 301681.

Now for the Index. If the decimal point is followed by a digit, the Index will be minus 1, which you will call 9. If the decimal point is followed by one zero, the Index will be minus 2, which you will call 8. If the decimal point is followed by two zeros, the Index will be minus 3, which you will call 7, and so on. Thus the Log. of $\cdot 23$ is $9\cdot 361728$; the Log. of $\cdot 023$ is $8\cdot 361728$, and so on. What you do is, in fact, to borrow 10 for the use of the Index when it is *minus*, and call the balance *plus*. This is the reason why, when you come later on to deal with cosines and such things, you will have to drop tens in the Index. You will be giving back tens, which you have borrowed in order to turn minus Indices into plus Indices for the sake of convenience; but you need not bother your head about this now.

Now suppose you want to reverse the operation, and find the natural number of a Log., say $9\cdot 361728$. 361728 gives you 23, the Index is 9. Therefore if the 9 is really a plus 9, the natural number must have ten figures, and would be 2300000000; but if the Index 9 represents minus 1, the natural number must be a decimal, $\cdot 23$. If your Log. is $8\cdot 361728$, the natural number is either 230000000 or $\cdot 023$, and so on and so on. 'Well,' you may say, 'how

am I to know which it is ?' The nature of your work will tell you. The difference between $\cdot 23$ (twenty-three hundredths) and 2,300,000,000 (two thousand three hundred millions) is so great that you cannot very well make a mistake.

Here is how the Logs. of a natural number decreasing in value from four integers or whole numbers to decimals would look carried right through the scale.

Take any number, say 3456. The Mantissa or decimal part of the Log. will of course always remain the same ; the Index only will change.

3456	Log.	3·538574
345·6	„	2·538574
34·56	„	1·538574
3·456	„	0·538574
·3456	„ - 1 or	9·538574
·03456	„ - 2 or	8·538574
·003456	„ - 3 or	7·538574

and so on and so on.

Take any Log. and reverse the process. Take the Mantissa 606596.

3·606596	gives nat. number	4042
2·606596	„	404·2
1·606596	„	40·42
0·606596	„	4·042
- 1 or 9·606596	„	·4042
- 2 or 8·606596	„	·04042
- 3 or 7·606596	„	·004042

and so on and so on.

To multiply and divide mixed numbers.—To multiply and divide mixed numbers—that is, numbers consisting of integers and decimals—add and subtract the Logs. as has been explained before ; the operation is quite simple, and the only possible difficulty you can experience is in respect of the Indices.

In addition of the Logs., as the Indices are either zero or plus quantities, the Index of the sum is either zero or plus. But in subtraction the result may be a minus quantity. Therefore in subtraction of the Logs., if the

Log. of the divisor exceeds the Log. of the dividend, you will have to borrow 10 for the use of the Index of the Log. of the dividend. If you paid the ten back, the Index would be minus, but you keep the ten in order to make the Index plus, as already explained.

Here are some examples :—

I. Multiply 6·82 by 17·8, by Logs.

$$\begin{array}{r} 6\cdot82 \text{ Log. } 0\cdot833784 \\ 17\cdot8 \quad \text{,,} \quad 1\cdot250420 \\ \hline 2\cdot084204 \end{array}$$

The nearest less Mantissa to ·084204 is ·083861, which gives the natural number 1213, and the difference between them is 343. This 343 divided by the Diff. in the Tables, 357, gives 9 to be tacked on to 1213, and the Index being 2, there must be three integers in the answer.

$$\begin{array}{r} 2\cdot084204 \\ \text{Nat. No. } 1213 \quad \cdot083861 \text{ Nearest Log.} \\ \text{Diff. } 357 \text{) } 3430 \text{ (9 to be tacked on to } 1213 \\ \quad \quad \quad 3213 \end{array}$$

and 121·39 is the answer.

Check.—Decimal point is right, because $6 \times 17 = 102$, and is pretty near 121.

It is unnecessary to go through all the steps in every example for the future, as you must have got it well into your head how to add and subtract Logs. If not, turn back and study that question a little more. In the next example, therefore, I merely give the figures.

II. Multiply 182·7 by 6·495.

$$\begin{array}{r} 182\cdot7 \text{ Log. } 2\cdot261738 \\ 6\cdot495 \quad \text{,,} \quad 0\cdot812579 \\ \hline 3\cdot074317 \\ \text{Nat. No. } 1186 \quad \cdot074085 \text{ Nearest Log.} \\ \text{Diff. } 366 \text{) } 2320 \text{ (6 to be tacked on to } 1186 \\ \quad \quad \quad 2196 \end{array}$$

The answer is 1186·6.

Check.—Answer should be somewhere near 200×6 , or 1200 ; thus decimal is evidently in the right place.



THIS PAGE IS LOCKED TO FREE MEMBERS

Purchase full membership to immediately unlock this page

DELVE INTO FANTASY, MAGIC, MYTHOLOGY & FOLKLORE

Forgotten Books'
Full Membership gives
access to 797,885 ancient
and modern, fiction and
non-fiction books.

Continue

*Fair usage policy applies

borrowed and not returned. So much for quantities composed of integers and decimals.

To multiply and divide numbers consisting entirely of decimals.—Under these circumstances the Indices are always minus. You have, therefore, to borrow ten for each Log. Pay back both the tens if you can, in which case the Index of the result is a plus quantity. But if you can only pay back one ten, the Index, though really a minus quantity, is converted into a plus quantity by retaining the ten.

I. Multiply $\cdot 234$ by $\cdot 0234$.

Log. of $\cdot 234$ is $9\cdot 369216$ (the Index is really -1 , because there is no integer in the number). The Log. of $\cdot 0234$ is $8\cdot 368216$ (the Index is really -2 , because, if such an expression is permissible, there is one less than no integer in the number).

$$\begin{array}{r} 9\cdot 369216 \\ 8\cdot 368216 \\ \hline 17\cdot 738432 \end{array}$$

You have borrowed twenty, namely ten on each Log. : retain ten to preserve a plus Index, and pay back ten, and you get the Log. $7\cdot 738432$. 738432 gives you the natural number 5476 nearly and near enough, which with 7 or -3 , in the Index, gives you $\cdot 005476$ as the product of $\cdot 234 \times \cdot 0234$.

Check.— $\cdot 2 \times \cdot 02 = \cdot 004$.

II. Multiply $\cdot 7$ by $\cdot 825$.

$$\begin{array}{r} \cdot 7 \quad \text{Log. } 9\cdot 845098 \\ \cdot 825 \quad \text{,, } \quad 9\cdot 916454 \\ \hline \text{Nat. No. } \cdot 5775 \quad 9\cdot 761552 \end{array}$$

The answer is $\cdot 5775$.

Here also you have borrowed two tens and only returned one, therefore the Index of the Log. of the product represents a minus quantity.

Check.— $\cdot 7 \times \cdot 8 = \cdot 56$.

III. Multiply $\cdot 049$ by $\cdot 0063$.

$$\begin{array}{r} \cdot 049 \text{ Log. } 8\cdot 690196 \\ \cdot 0063 \text{ ,, } \quad 7\cdot 799341 \\ \hline \text{Nat. No. } \cdot 0003087 \quad 6\cdot 489537 \end{array}$$

The answer is $\cdot 0003087$.

For the same reason as in the two preceding examples the Index of the Log. of the product represents a minus quantity.

Check.— $\cdot 05 \times \cdot 006 = \cdot 00030$.

IV. Suppose you want to divide $\cdot 0234$ by $\cdot 345$. The Log. of $\cdot 0234$ is $8\cdot 369216$, and the Log. of $\cdot 345$ is $9\cdot 537819$.

$$\begin{array}{r} 8\cdot 369216 \\ 9\cdot 537819 \\ \hline 8\cdot 831397 \end{array}$$

831397 gives the natural number 6783 . 8 in the Index makes the number $\cdot 06783$, which is the quotient of $\cdot 0234 \div \cdot 345$.

In this case you have borrowed ten for each Log.; they neutralise each other; and you have borrowed an additional ten in order to be able to subtract, and you retain this ten to provide a plus Index.

But if you do not require to borrow ten to preserve a plus Index, it will be a positive one. Thus:

V. Divide $\cdot 224$ by $\cdot 035$.

$$\begin{array}{r} \cdot 224 \text{ Log. } 9\cdot 350248 \\ \cdot 035 \text{ ,, } \quad 8\cdot 544068 \\ \hline \text{Nat. No. } 6\cdot 4 \quad 0\cdot 806180 \end{array}$$

Ten has not been borrowed, and the Index is zero, as above.

The answer is $6\cdot 4$.

VI. Divide $\cdot 1$ by $\cdot 0001$.

$$\begin{array}{r} \cdot 1 \text{ Log. } 9\cdot 000000 \\ \cdot 0001 \text{ ,, } \quad 6\cdot 000000 \\ \hline \text{Nat. No. } 1000 \quad 3\cdot 000000 \end{array}$$

and 1000 is the answer.

To sum up. In division by Logs., (1) when the Index of the Log. of the dividend is greater than the Index of

the Log. of the divisor, the Index of the Log. of the quotient is a *plus* quantity. (2) When the Index of the Log. of the dividend is less than the Index of the Log. of the divisor, the Index of the quotient is a *minus* quantity, and has to be turned into a plus quantity by borrowing a ten.

Proportional Logs. and how to Use them

Table XXXIV. gives Proportional Logs. for Time or 'Arc' from 0 h. 0 m. or $0^{\circ} 0'$ to 3 h. or 3° . The hours and minutes, or degrees and minutes, are at the top, and the seconds are given at the sides. Look out the time or arc, and write down the appropriate Log.

Find the arithmetical complement of the Log. of the first term. The arithmetical complement, or ar. co., is found by taking the Log. from 10.0000. Then add together the ar. co. Log. of the first term and the Logs. of the second and third terms; the result, rejecting tens in the Index, is the Log. of the answer x .

For example, take the sum we have worked on p. 5, namely :

$$\begin{array}{r} \text{As } 17^{\text{m}} 2^{\text{s}} : 3^{\text{m}} 46^{\text{s}} :: 2^{\circ} 55' 58'' : x \\ 17^{\text{m}} 2^{\text{s}} \text{ Log. } 1.0240 \left(\begin{array}{l} 10.0000 \\ 1.0240 \end{array} \right) = \text{ar. co. Log. } 8.9760 \\ \quad \quad \quad 3^{\text{m}} 46^{\text{s}} \text{ Prop. Log. } \quad \quad \quad . \quad \quad \quad 1.6793 \\ \quad \quad \quad 2^{\circ} 55' 58'' \text{ Prop. Log. } \quad \quad \quad . \quad \quad \quad \underline{0098} \\ \quad \quad \quad 38' 55'' \quad \quad \quad . \quad \quad \quad \text{Prop. Log. } 0.6651 \end{array}$$

This, you will admit, is a simple and expeditious way of working a sum in proportion.

That is all there is to be said about Logarithms, and quite enough too. I could never see the object of requiring such an intimate knowledge of Logs. in all their twists and turns and subtleties on the part of candidates for a

certificate of competency, seeing that all the problems given for a master can be solved if you know how to find the Log. of a natural number of four integers, and to take out the natural number of four integers of the nearest Log. But so it is; the knowledge is required, and must be acquired. It is a puzzling subject, and the student should work a lot of exercises in it. For this reason any amount of exercises are given in the second volume.

In case you should like to know now, or at some future time, what Logarithms really are, here follows a very brief description; but don't bother to read it unless you have a mind to.

The Logarithm of a number is the power to which the base must be raised to produce that number. Any number may be the base, but in all Nautical Tables 10 is the base.

With the base 10, suppose the Log. of 100 is wanted. $10 \times 10 = 100$; 10×10 is ten squared, or 10^2 , that is 10 raised to power 2; therefore 2 is the Log. of 100.

Suppose you want the Log. of 1000. $10 \times 10 \times 10 = 1000$; $10 \times 10 \times 10$ is 10^3 , 10 raised to power 3; therefore 3 is the Log. of 1000.

Now you will see why *addition* of their *Logs.* is the same as *multiplication* of numbers.

$10 \times 10 \times 10 \times 10 \times 10$ is 10^5 . $(10 \times 10) \times (10 \times 10 \times 10)$ is 10^5 . 10×10 is 10^2 . $10 \times 10 \times 10$ is 10^3 . 2 is the Log. of 10^2 , and 3 is the Log. of 10^3 . $2 + 3 = 5$, therefore the addition of the Logs. of 10×10 and of $10 \times 10 \times 10$ produces the same result as the multiplication of the numbers $10 \times 10 \times 10 \times 10 \times 10$, namely 10^5 .

Also you will see why *subtraction* of their Logs. produces the same result as *division* of numbers.

Suppose you want to divide 1000 by 100. The Log.

of 1000 is 3, and the Log. of 100 is 2. $1000 \div 100 = 10^1$.
 $3 - 2 = 1$, which is the Log. of 10.

The Log. of 1 is 0. $100 \div 100 = 1$. The Log. of
 100 is 2. $2 - 2 = 0$.

Suppose you want to raise a number to any given power. All you have to do is to multiply the Log. of the number by the given power. For instance, suppose you wish to raise 10^2 to its fifth power, that is to say to 10^{10} . The Log of 10^2 is 2, and 5 is the power to which 10^2 is to be raised. $2 \times 5 = 10$. $10^2 \times 10^2 \times 10^2 \times 10^2 \times 10^2 = 10^{10}$. So you see that 10^2 multiplied together five times is 10^{10} , and that 2, the Log. of 10^2 , multiplied by 5 is the Log. of 10^{10} .

The Logs. of all numbers which are not tens or multiples of tens are obviously fractional. From what has been said it is also obvious that Logs. of numbers between one and ten must lie between zero and one, and that the Logs. of numbers between ten and one hundred must be more than one and less than two, and so on. Hence it is that the Index of a Log. is one less than the number of digits in its natural number. The Logs. of fractions must always be of a minus description. If you divide the less by the greater, the result must be less than unity. Ten divided by one hundred expressed in Logs. is one minus two. $1 - 2 = -1$. Hence the minus Indices already spoken about, which are for convenience sake expressed as plus Indices by using their arithmetical complements.

CHAPTER III

INSTRUMENTS USED IN CHART AND COMPASS WORK

THE instruments which are necessary for the purpose of navigating a ship by Dead Reckoning are the following:—

1. Mariner's Compass.
2. Instrument for taking Bearings in connection with the Mariner's Compass.
3. Lead.
4. Log.
5. Parallel Rulers.
6. Dividers.
7. Protractors.

The following instruments, though not absolutely necessary, are extremely useful, namely:—

8. Pelorus.
9. Station Pointer.

The Mariner's Compass

The Mariner's Compass consists of a Compass Card under which are secured one or more magnets lying exactly parallel with a line joining the North and South points on the Compass Card, and with their Positive or Red Poles towards the North point. This Card is fitted under its centre with a cap of agate or some similar hard stone

which rests upon the hard and sharp point of an upright metal rod, firmly fixed to the bottom of the Compass Bowl. By this means the card is accurately and delicately balanced upon its centre. The Compass Bowl is made of copper, because that metal does not affect the Needle. The bowl is hung on gimbals, so arranged that it always remains horizontal, no matter at what angle the binnacle to which the gimbals are fastened may be canted. The binnacle is generally a hollow wooden column, fitted with slides inside for the compensating magnets, and having some arrangement on either side at the same height as the Compass Needles for supporting the soft iron correctors; it should also have perpendicular slots on both its forward and after sides, in the fore and aft line for placing a Flinders Bar, should it be required.

The essentials of a good Compass are, that its Magnets should be extremely powerful, and as light as possible. The cap in the Compass Card should be perfectly smooth, not rough or cracked, and the pivot on which it is balanced should also be quite smooth and free from rust. The Card, if deflected mechanically, should return to exactly the point from which it was twisted. It must be divided into points, half points, and quarter points and degrees with the greatest accuracy. The point of the pivot should be in the same plane as the gimbals of the bowl when the ship is upright. In the case of a Standard Compass, a clear view of the Horizon all round should if possible be obtainable, so that the bearing of any object can be taken with the ship's head in any position. The vertical line, called the Lubber Line, marked on the Compass Bowl, must be exactly in the fore and aft line of the ship.

In choosing a Compass go to a good maker, and pay a good price for a good article.



THIS PAGE IS LOCKED TO FREE MEMBERS

Purchase full membership to immediately unlock this page

SAVE \$3,999,994

Did you know we sell
paperback books too?

To buy our entire catalog
in paperback would cost
over \$4,000,000

Access it all now for
\$8.99/month

*Fair usage policy applies

Continue

which the reflection of an object can be projected on to the rim of the Compass Card.

To take a bearing with the Azimuth Mirror, turn the instrument round until the object is roughly in a line with your eye and the centre of the Compass Card. Then, looking at the rim of the Compass Card through the lens, revolve the prism till the image of the object falls on the rim of the Compass Card; read off the degree on which the image appears, and you have the bearing of the object. Some little difficulty may at first be experienced in using the instrument; in this case, as in so many others, 'practice makes perfect,' and after a few trials and the exercise of a little patience you will find that you can get the bearings of objects on shore, of ships, and of the sun, moon, and stars with very great accuracy and ease. It is not advisable to take the Azimuth of a star whose Altitude exceeds 30° .

As the prism inverts the object observed, ships, objects on shore, or a coast-line appear upside down, but you will soon become accustomed to that.

See that the Compass is level by putting pennies, or sovereigns if you have them, on the glass till the air bubble is as near the centre as possible.

A shadow pin—a pin placed perpendicularly over the pivot of the Compass—affords an easy way of getting Azimuths of the Sun. Take the bearing of the shadow of the pin and reverse it, and you have the bearing of the Sun.

The Lead and Lead Line

There are two descriptions of ordinary Leads, namely, Hand Leads and Deep Sea Leads. Their names indicate the difference between them. Hand Leads are of different weights, but they rarely exceed 9 lb. Deep Sea Leads

often weigh 30 lb. and even more. Hand Leads are hove by one man, and are no use except in shallow water. When a ship is going 9 knots it takes a good leadsman to get bottom in 9 fathoms.

Deep Sea Leads are for getting soundings in deep water, 100 fathoms and more sometimes. It is necessary when using an ordinary Deep Sea Lead to heave the ship to. The line is reeled off until there is a sufficient amount of loose line to reach the bottom. The Lead, which has an aperture in the lower end of it, in which grease is put (this is called the arming), is taken on to the lee cathead or fore tack bumpkin; the end of the lead line is passed forward from the lee quarter, where the reel is, outside everything and secured to the lead. A line of men is formed along the bulwarks, each of whom has a coil of lead line in his hand. When all is ready the man at the cathead heaves the Lead from him as far to leeward as he is able, calling out 'Watch there, watch.' Each man as his coil runs out repeats this to the next man astern until the bottom is reached, or until all the line is run out if the Lead has not reached the bottom.

This clumsy operation is nowadays almost completely superseded by Lord Kelvin's Patent Sounding Machine. It depends for accuracy upon the increase of pressure in the sea as the depth increases, which the instrument records thus :

A glass tube descends with the lead. It is hermetically closed at the upper end and open at the lower; its interior surface is coated with a chemical preparation, which becomes discoloured when salt water touches it. As the depth of water increases the pressure becomes greater, and the air in the glass tube is compressed as the salt water is forced into it; the discoloration of the chemical coating shows exactly how high the

water rose in the tube, and by means of a scale applied to the side of the tube the depth of water which causes that pressure is read off.

To accelerate the descent of the Lead, piano wire is used for the lead line; the wire is wound upon a drum fixed to one of the ship's quarters, which enables a few men to haul in the Lead after a cast, instead of, as under the old system, very often requiring the whole ship's company. With Lord Kelvin's machine bottom can be reached at 100 fathoms, with the ship going, it is said, as much as 15 or 16 knots.

The old-fashioned lead line is marked as under :

At	2 fathoms	a piece of leather with two ends
„	3	„ „ „ three „
„	5	„ white calico
„	7	„ red bunting
„	10	„ leather with a hole in it
„	13	„ blue serge
„	15	„ white calico
„	17	„ red bunting
„	20	„ a strand with two knots
„	25	„ one „
„	30	„ three „
„	35	„ one „
„	40	„ four „
„	45	„ one „
„	50	„ five „
„	55	„ one „
„	60	„ six „
„	65	„ one „
„	70	„ seven „
„	75	„ one „
„	80	„ eight „
„	85	„ one „
„	90	„ nine „
„	95	„ one „
„	100	„ a piece of bunting

and then the marking is repeated for the second hundred.

The difference of material is to enable the leadsman at night to identify the sounding without reference to the colour.

In heaving the Hand Lead, the leadsman must use his own judgment as to the depths obtained by reference to the position of the marks. He reports the sounding by the following cries :

Sounding	Cries
5 fathoms	' By the mark five '
6 ,,	' By the deep six '
6 $\frac{1}{2}$..	' And a half six '
7 $\frac{3}{4}$,,	' A quarter less eight
10 $\frac{1}{4}$..	' And a quarter ten '

and so on.

The Logship and Log Line

The old-fashioned Logship is generally a piece of wood in the form of the segment of a circle. It has lead run into its circular part, so that when in the water it will float upright with the rim down. A hole is bored in each corner, and it is fastened to the Log line with three cords, in such a fashion that its plane is perpendicular to the pull of the line. One of these cords is so fastened to the Logship, that when a heavy strain is put upon it, it comes loose, which allows the Logship to lie flat in the water when it is being hauled on board after use.

Sometimes a conical canvas bag is used for a Logship, arranged so that it presents its mouth to the direction of the pull of the Log line while the Log is being hove, and its point when it is being hauled in.

The idea in each of these cases is to make the Logship as nearly stationary as possible while the line is running out, and to offer the least possible resistance when it is being hauled on board.

The principle involved in the Log line is a simple proportion. The ordinary length of the Log glass is 28 seconds.

As 28 seconds : 1 hour :: the length of line : the length of line that
run out in 28" : would run out in 1^h

Now, supposing the ship to be travelling one mile in one hour, we have the following proportion :—

$$\begin{array}{r}
 28 \text{ seconds} : 1 \text{ hour} \quad : : x : 1 \text{ nautical mile} \\
 \qquad \qquad \qquad \underline{60} \qquad \qquad \qquad \qquad \qquad \qquad \qquad \underline{2040} \\
 \qquad \qquad \qquad 60 \text{ minutes} \qquad \qquad \qquad \qquad \qquad \qquad \underline{2040} \text{ yards} \\
 \qquad \qquad \qquad \underline{60} \qquad \qquad \qquad \qquad \qquad \qquad \underline{\qquad \qquad 3} \\
 28 \text{ seconds} : 3600 \text{ seconds} \quad : : x : 6120 \text{ feet} \\
 \qquad \qquad \qquad \qquad \qquad \qquad \qquad \underline{6120} \\
 \qquad \qquad \qquad \qquad \qquad \qquad \qquad \underline{28} \\
 \qquad \qquad \qquad \qquad \qquad \qquad \qquad \underline{\qquad \qquad \qquad} \\
 \qquad \qquad \qquad \qquad \qquad \qquad \qquad \underline{48960} \\
 \qquad \qquad \qquad \qquad \qquad \qquad \qquad \underline{12240} \\
 \qquad \qquad \qquad \qquad \qquad \qquad \qquad \underline{\qquad \qquad \qquad} \\
 \qquad \qquad \qquad 3600 \text{) } 171360 \text{ (} \begin{array}{l} \text{ft.} \\ \text{in.} \end{array} \begin{array}{l} 47 \\ 7 \end{array} \text{ very nearly} \\
 \qquad \qquad \qquad \underline{14400} \\
 \qquad \qquad \qquad \underline{\qquad \qquad \qquad} \\
 \qquad \qquad \qquad \qquad \qquad \qquad \underline{27360} \\
 \qquad \qquad \qquad \qquad \qquad \qquad \underline{25200} \\
 \qquad \qquad \qquad \qquad \qquad \qquad \underline{\qquad \qquad \qquad} \\
 \qquad \qquad \qquad \qquad \qquad \qquad \underline{2160} \\
 \qquad \qquad \qquad \qquad \qquad \qquad \underline{12} \\
 \qquad \qquad \qquad \qquad \qquad \qquad \underline{\qquad \qquad \qquad} \\
 \qquad \qquad \qquad \qquad \qquad \qquad \underline{25920} \\
 \qquad \qquad \qquad \qquad \qquad \qquad \underline{25200}
 \end{array}$$

That is to say, if a ship is travelling at the rate of 1 knot per hour, she will run out 47 ft. 7 in. of line, very nearly, in 28 seconds. It is, therefore, quite clear that if she is sailing at the rate of 2 knots per hour, she will run out in 28 seconds twice 47 ft. 7 in. ; if she is going 3 knots, three times 47 ft. 7 in.

Again, if a 14-second glass is used, she will clearly only run out half the line she would, had a 28-second glass been used, and therefore if she ran out 47 ft. 7 in. in 14 seconds, she would run out twice 47 ft. 7 in. in 28 seconds. In other words, she would be going two knots.

The Log line is marked thus :

About 10 fathoms of ‘stray line’ are allowed between the Logship and the first mark on the line, which consists of a piece of white bunting or rag. At the distance of 47 ft. 7 in. from this mark a piece of twine with 1 knot is placed ; at a further distance of 47 ft. 7 in. a piece of twine with 2 knots is placed ; at a further distance of

47 ft. 7 in. a piece with 3 knots is placed, and so on generally up to about 7 knots. Halfway between these knots a single knot is placed. So we have the following marks, at a distance of the half of 47 ft. 7 in. apart: A white piece of rag, 1 knot, 1 knot, 1 knot, 2 knots, 1 knot, 3 knots, 1 knot, 4 knots, 1 knot, 5 knots, 1 knot, 6 knots, 1 knot, 7 knots, 1 knot. If the 28-second glass is used, the knots run out indicate the speed of the ship; but if the 14-second glass is used, the number of knots run out must be doubled to give you her speed.

In practice the Log is hove thus:

A man stands with the reel, on which the Log line is held above his head, so that it can run clear of everything. Another man holds the Log glass, seeing that the upper bulb is clear of sand. The man heaving the Log sees that the Logship is properly fastened, and asks if the Log glass is clear. He then throws the Log as far to leeward as he can, and lets the Logship run the line off the reel, till the white mark passes through his hands, when he says 'Turn' to the man holding the Log glass, who instantly reverses it. When the sand has run out, the man holding the glass calls 'Stop,' and the Log line is seized and prevented from running out any more. The number of knots run out gives the speed of the vessel, as explained already.

Patent Logs, which indicate the number of miles the ship has gone through the water, possess so great an advantage over the ordinary Log, which only tells you the rate of the ship at the moment of heaving the Log, that the latter has become quite out of date, patent Logs being now invariably used at sea.

The patent Logs most commonly used are two in number. One is called the Harpoon Log, and the other the Taffrail Log.

The Harpoon Log is shaped like a torpedo, and has at one end a metal loop to which the Log line is fastened, and at the other, fans which cause the machine to spin round as it is drawn through the water. The spinning of the instrument sets a clockwork machinery in motion, which records the speed of the vessel upon dials, the rotation of the instrument being, of course, dependent upon the rate at which it is dragged through the water. When you want to know the distance your ship has run, you must haul in the Log and read it off on the dial.

The Taffrail Log is called so because the dial which contains the recording machinery is secured to the taffrail. It is connected by a long line with a fan towing astern, which revolves when dragged through the water, and makes the line spin round. This causes the machinery in the dial to indicate on the face of the dial the distance travelled. The advantage of using the Taffrail Log is that it can be consulted at any time without having to haul the line in; and, as it is usually fitted with a small gong which strikes as every one-eighth of a mile is run out, it is a simple matter to find out the speed of the ship at any moment by noting the time elapsing between two successive strokes of the gong.

Parallel Rulers

For chart work parallel rulers are indispensable. They are simply rulers so arranged that you can move them over a chart and their edges will always remain parallel to any line from which they may have started. Of course there is some danger, if the distance to be moved is considerable, of the ruler slipping, particularly when a ship is knocking about. And I strongly recom-



THIS PAGE IS LOCKED TO FREE MEMBERS

Purchase full membership to immediately unlock this page

DELVE INTO FANTASY, MAGIC, MYTHOLOGY & FOLKLORE

Forgotten Books'
Full Membership gives
access to 797,885 ancient
and modern, fiction and
non-fiction books.

Continue

*Fair usage policy applies

Protractors

The most useful form of protractor for chart work is made of horn or celluloid. It is very convenient to have a thread or piece of silk attached to the centre, as the measurement of angles is greatly facilitated thereby. The ordinary protractor is divided into degrees radiating from the centre. It is usually a semicircle, the horizontal line passing through the centre being marked 90° at each end, and the vertical line 0° .

To measure a Course ruled on the chart, place the centre of the protractor on the point where the Course cuts any Meridian, and see that the zero on the vertical line of the protractor is also on the same Meridian. You can now read off the angle of the Course where it passes under the semicircular edge of the protractor.

The above instruments are essential, and the following will be found very useful :

The Pelorus

A Pelorus is a dumb Compass Card—that is, a card without a needle—fitted with sight vanes for taking bearings. It is usually placed on a stand, and so mounted that the Card can be turned round to any desired position, and there fixed by means of a screw. The sight vanes can also be turned round and fixed to the Card at any required bearing.

It is a handy instrument for determining Compass Error, and also for placing the Ship's Head in any position that may be wished. Its use will be more fully explained later on in the chapter on Magnetism and Compass Correction.

Station Pointer

A Station Pointer is an instrument with three legs by which, when used in conjunction with a chart, the position of a ship can be quickly ascertained when the angular distance between three objects on shore is known either by measurement or by their bearings. With the three legs measuring the angular distance between the three objects and clamped, place the instrument on the Chart in such a position that the legs are exactly even with the three objects on the Chart; the ship's position is indicated by the centre of the Station Pointer.

CHAPTER IV

THE PRACTICAL USE OF THE COMPASS

A COMPASS Card is, like all other circles, divided into 360 degrees. Each degree ($^{\circ}$) consists of 60 minutes ($'$), and each minute contains 60 seconds ($''$). It has four Cardinal Points, North, South, East, and West; four Quadrantal Points, NE, SE, SW, and NW; and twenty-four intermediate Points, as shown in the figure, thus making thirty-two Points in all. As there are 360° in any circle, each Point contains $11^{\circ} 15'$; that is, 360° divided by 32. Each Point is subdivided into half and quarter Points.

As the Compass Card moves freely on its pivot, the North Point of the Card is caused by the Compass Needle to point towards the North Pole of the earth.

In speaking of the direction of any object from the ship, or of the direction in which a ship is proceeding, it is equally accurate to use Points, half Points, and quarter Points, or Degrees, Minutes, and Seconds; but as in many cases their use simplifies calculation very much, it is advisable for the student to use Degrees and parts of Degrees.

The Bearing by Compass of any object is the angle, at the centre of the Compass Card, between the North and South line on the Card and an imaginary straight line drawn from the centre of the Compass Card to the object. A Bearing is measured along the circumference of the Compass Card, so many Degrees and parts of a Degree

from the North or South Points on the Compass Card to where the imaginary line cuts the circumference of the Card.

On the inside of each Compass Bowl a vertical line is marked, indicating the line of the keel of the vessel. This is called the 'lubber line.' Whatever Degree, Point, half

FIG. 1.—COMPASS CARD

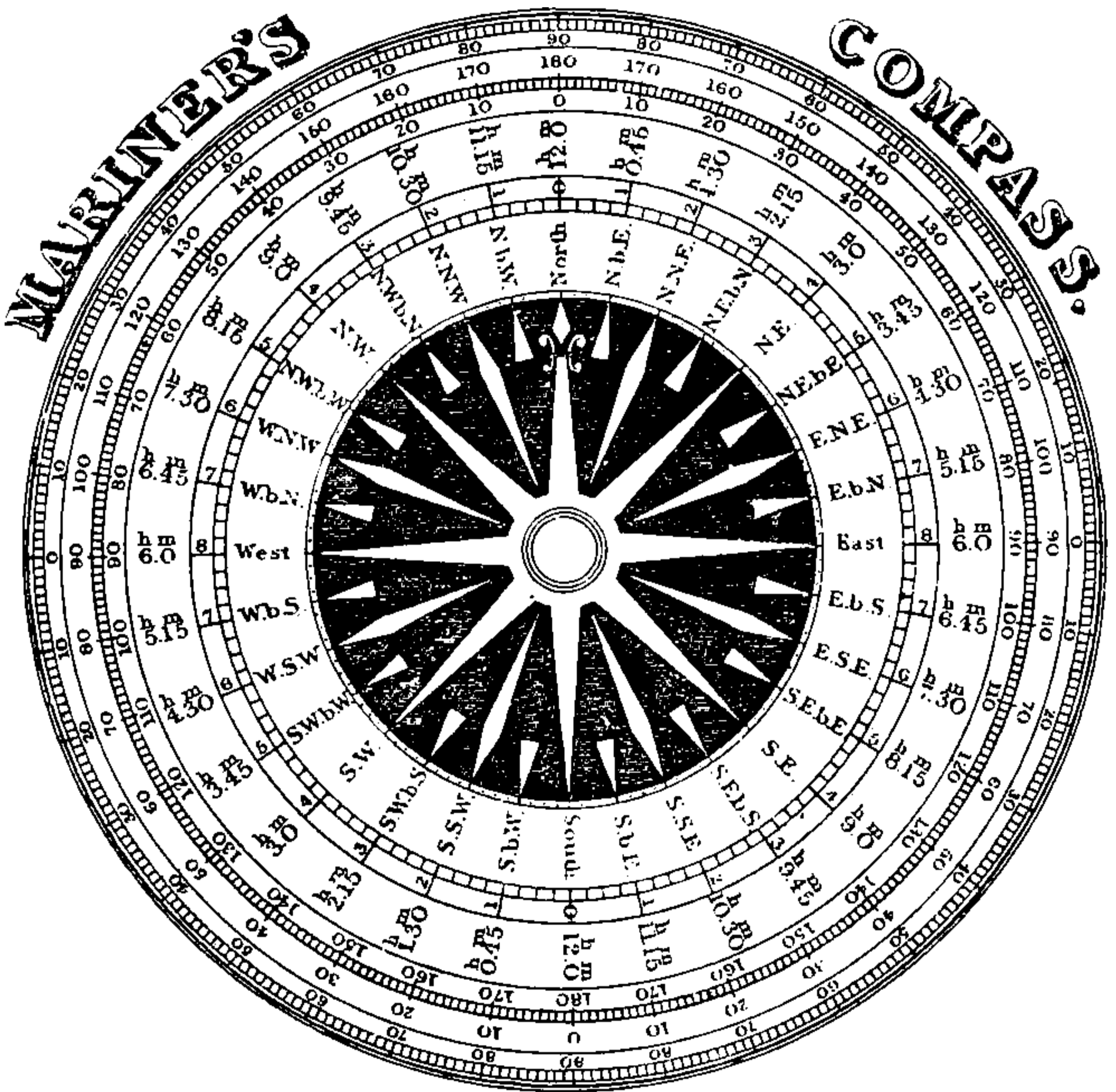

Point, or quarter Point is opposite the lubber line, is the Compass Course you are steering.

Variation.—The Compass Needle is supposed to point North and South with unswerving fidelity—'true as the Needle to the Pole' is the idea. But unfortunately the idea is inaccurate, for the Needle very rarely points to the North and South Poles of the earth; if it did, the mariner

would be relieved of much anxiety and bother. It points towards what are called the North and South Magnetic Poles of the earth, situated in about Latitude 70° N and Longitude 97° W, and in Latitude 74° S and Longitude 147° E. Why it points in that direction goodness only knows; but it does—that is to say, it does when no disturbing causes affect it.

When the Needle does not point True North and South it makes a certain angle with the Meridian or True North and South line. This angle is called the '*Variation*' of the Compass. Variation varies in different parts of the globe, and is also constantly changing, but as the change is slow and the Variation is given on all charts, you can always find what it is by looking at your chart, unless you are using an antediluvian one. The Compass Needle affected by Variation and by nothing else is said to point *Correct Magnetic*.

Deviation.—But another and very inconvenient influence comes into operation in most ships, and in all vessels built of iron or steel. The ship itself is a Magnet, and its Magnetism affects the Compass Needle, causing it to diverge from the Correct Magnetic Meridian. The angle which it makes with the Correct Magnetic Meridian is called the '*Deviation*' of the Compass.

Thus it will be seen that any object may have three different bearings from a ship—namely, first, a *True Bearing*. This is the angle formed by an imaginary line drawn from the object to the Compass, and the True Meridian which passes through the Compass. Second, a *Correct Magnetic Bearing*, which is the angle formed by an imaginary line drawn from the object to the Compass, and the Magnetic Meridian which passes through the Compass. Third, a *Compass Bearing*, which is the angle formed by an imaginary line drawn from the object to the

Compass and the North and South line of the Compass Card.

If you want to know how an object bears for any charting work, you must first take the Bearing by Compass, and then correct the Compass Bearing for the Deviation due to the position of the ship's head; this correction will give you the Correct Magnetic Bearing. This is sufficient if you are using a Magnetic chart, that is to say, a chart the Compasses drawn on which show the Magnetic Points. But if you are using a chart showing only the True Points, or if for any other reason you want the True Bearing, you must correct the Correct Magnetic bearing for Variation. This will give you the True Bearing of the object, whatever it may be. The way of making these corrections will be explained later on.

Now, as to Courses, the same facts and considerations apply.

The True Course of a ship is the angle between her track through the water and the Meridian—that is to say, the True North and South line. To find it from a Compass Course, three allowances—namely, for Leeway, Deviation, and Variation—must be made. To a Correct Magnetic Course, Variation only must be applied.

The Correct Magnetic Course of a ship is the angle between the ship's track and the Magnetic Meridian, that is, the line joining the North and South Magnetic Pole of the earth. To find it from a Compass Course, Leeway and Deviation must be applied.

The Compass Course of a ship is the angle between the line of the ship's keel and the line of the North and South Points on the Compass Card.

If you know the True Course between two places, and want the Correct Magnetic Course, you must apply the Variation to the True Course, and there you are. Then

if you want the Compass Course the Deviation, if any, applied to the Correct Magnetic Course, will give it to you; and if your ship makes no Leeway, and there are no currents, you will get to your destination if you steer your Compass Course thus found. But if you are making Leeway, or if tides or currents are setting you across your Course, allowance must be made for them.

It is in making these corrections and allowances that the whole system of steering by Compass and using the Chart consists.

The converse, of course, holds true. If you know your Compass Course between two places, and want the Correct Magnetic Course, you must correct the former for Deviation; and if you require the True Course you must correct the Correct Magnetic Course for Variation.

Correction of Compass Courses

As in working all problems in the various sailings *True* Courses must be used, it is very necessary to understand how to turn a Compass Course into a True Course.

To find a True Course from a Compass Course.—In the first place bear in mind always that as the rim of the Compass Card represents the Horizon, you must always imagine yourself to be looking from the centre of the Card out towards the rim in the direction of the Course to be corrected.

The first thing to do is to correct your Compass Course for Leeway if the ship has made any. Leeway is the angle between the line of the keel and the track of the ship through the water, and is caused by the wind forcing the vessel sideways as well as forward. The amount of Leeway can only be judged by experience. The correction for Leeway must always be made in the



THIS PAGE IS LOCKED TO FREE MEMBERS

Purchase full membership to immediately unlock this page

SAVE \$3,999,994

Did you know we sell
paperback books too?

To buy our entire catalog
in paperback would cost
over \$4,000,000

Access it all now for
\$8.99/month

*Fair usage policy applies

Continue

Magnetic into a True Course—that is to say, if the Variation is *Westerly*, apply it to the *right*; if it is *Easterly*, apply it to the *left*.

The next operation is to allow for Deviation, and here comes the difficulty. You *do* know the Deviations on every position of the Ship's Head by *Compass*, but you do *not* know the Deviation for the Ship's Head on any given *Correct Magnetic* Course, and you have to find it out. The simplest plan is to find it by inspection—by drawing a small portion of a Napier's curve, as explained later on, and measuring off the Deviation from it; but you must also know how to calculate the Deviation, and the best way of doing so is as follows. Judge, by reference to your Deviation Card, whether the Deviation applicable to the Correct Magnetic Course which you wish to convert into a Compass Course will be to the right or to the left; then write down three *Compass* Courses, within the limits of which the Compass Course to be derived from the Correct Magnetic Course you are dealing with is pretty certain to be included. To these Compass Courses apply their respective Deviations, which, of course, you know. You have now three *Correct Magnetic* Courses. If the Correct Magnetic Course you are correcting is the same as one of these three Correct Magnetic Courses, then the Deviation which you used to find that Correct Magnetic Course is the Deviation to be applied to the Correct Magnetic Course you wish to convert into a Compass Course. Don't forget that in turning your three Compass Courses into Correct Magnetic Courses, you apply the Deviation directly, that is, East to the right, West to the left; and that in converting the Correct Magnetic into a Compass Course, you apply the Deviation indirectly, that is, East to the left, West to the right.

But it may, and probably will, happen that not one of the three Compass Courses you have turned into Correct Magnetic Courses coincides exactly with the Correct Magnetic Course you have to turn into a Compass Course. In such an event you must do a little sum in simple proportion.

You have got three Correct Magnetic Courses, on which you know the Deviation. You find that the Correct Magnetic Course you have to convert to a Compass Course lies between two of them. Take the difference between these two Correct Magnetic Courses, and call it A. Take the difference between one of them and the Correct Magnetic Course you are dealing with, and call it B. Take the difference between the Deviations on the two Correct Magnetic Courses used, and call it C. Then as A is to B so is C to the answer. Multiply B by C and divide the result by A. The result gives you the portion of Deviation to be added to or subtracted from the Deviation belonging to that Correct Magnetic Course from which B was measured ; whether it is to be added or subtracted, will be apparent on the face of the case.

It may also happen that, having turned your three Compass Courses into Correct Magnetic, you will find that the Correct Magnetic you desire to turn into Compass does not lie within their limits, but is less than the least of them, or greater than the greatest of them ; in which case you must select one or two more Compass Courses to convert until you have two Correct Magnetic Courses, one greater and the other less than the Correct Magnetic Course you are dealing with, or, if you are lucky, one of which coincides exactly with it. This is a long explanation, and sounds complicated, but it really is simple, and its simplicity will best be shown by one or two examples, worked with the following Deviation Card.

It will be seen that the Deviation is given for the Ship's Head on every Point by Compass.

DEVIATION CARD

Ship's Head by Standard Compass	Deviation	Ship's Head by Standard Compass	Deviation
North	13° 30' E	South	13° 54' W
N b E	11° 48' E	S b W	6° 18' W
N N E	9° 48' E	S S W	0° 56' E
NE b N	6° 42' E	SW b S	7° 48' E
N E	2° 35' E	S W	13° 37' E
NE b E	2° 29' W	SW b W	18° 3' E
E N E	8° 16' W	W S W	21° 0' E
E b N	14° 23' W	W b S	22° 29' E
East	20° 18' W	West	22° 42' E
E b S	25° 31' W	W b N	22° 1' E
E S E	29° 28' W	W N W	20° 44' E
SE b E	31° 45' W	NW b W	19° 15' E
S E	31° 59' W	N W	17° 47' E
S E b S	30° 6' W	NW b N	16° 32' E
S S E	26° 16' W	N N W	15° 32' E
S b E	20° 28' W	N b W	14° 22' E

Now suppose you want to sail from any one place to another, let us call it from A to B. You lay the edge of your parallel ruler on A and B, and working them to the nearest Compass on the Magnetic Chart you find that the Correct Magnetic Course to steer is, let us say, S b W $\frac{1}{2}$ W.

On looking at the Deviation Card you see that the Deviation with the Ship's Head on S b W $\frac{1}{2}$ W is changing very rapidly. On a S b W Compass Course it is 6° 18' W, and on a SSW Compass Course it is 0° 56' E. It is probable that by applying the Deviations to these two Compass Courses you will get the two Correct Magnetic Courses between which the Course you wish to steer lies.

Proceed thus. Turn the Compass Course into degrees and parts of a degree, and apply the Deviation.

Compass Course S b W = S 11° 15' W Deviation 6° 18' W <hr style="width: 50%; margin-left: 0;"/> Correct Magnetic Course S 4° 57' W	Compass Course SSW = S 22° 30' W Deviation 0° 56' E <hr style="width: 50%; margin-left: 0;"/> Correct Magnetic Course S 23° 26' W
---	--

Now the Correct Magnetic Course we want to steer is S b W $\frac{1}{2}$ W, which is S 16° 52' 30" W, and this lies between

the above Correct Magnetic Courses, namely, S 4° 57' W and S 23° 26' W.

To proceed.

Find the difference between the two Correct Magnetic Courses	Find the difference between the nearest Correct Magnetic Course, namely, S 4° 57' W and S 16° 52' 30'' W	Find the difference between the Deviations due to the Compass Courses you have converted
S 4° 57' W	S 4° 57' W	6° 18' W
S 23° 26' W	S 16° 52' 30'' W	0° 56' E
<hr/> 18° 29' W	<hr/> 11° 55' 30''	<hr/> 7° 14'

Then, as 18° 29' : 11° 55' 30'' :: 7° 14' : x .

To simplify the sum, use the nearest decimals of a degree, and say: as 18°·5 : 11°·9 :: 7°·2 : x .

Multiply the second and third term, and divide by the first term.

$$\begin{array}{r}
 11\cdot9 \\
 7\cdot2 \\
 \hline
 238 \\
 833 \\
 \hline
 18\cdot5) 85\cdot68 (4\cdot6 \\
 \underline{740} \\
 1168 \\
 \underline{1110}
 \end{array}$$

Therefore, 4°·6 or 4° 36' is the correction to be applied to the Deviation on the nearest Course, which is S b W, or S 11° 15' W, and it must be subtracted, because the Deviation Westerly is decreasing.

$$\begin{array}{r}
 \text{Deviation on S } 11^{\circ} 15' \text{ W (Compass Course)} = 6^{\circ} 18' \text{ W} \\
 \text{(Correction)} \quad \quad \quad \underline{4^{\circ} 36'} \\
 \hline
 1^{\circ} 42' \text{ W}
 \end{array}$$

1° 42' is therefore the Deviation to be applied to the Correct Magnetic Course S b W $\frac{1}{2}$ W.

$$\begin{array}{r}
 \text{S b W } \frac{1}{2} \text{ W} = \text{S } 16^{\circ} 52' 30'' \text{ W} \\
 \text{Deviation} = \quad \quad \underline{1^{\circ} 42'} \quad \text{W} \\
 \hline
 \text{S } 18^{\circ} 34' 30'' \text{ W}
 \end{array}$$

S b W $\frac{3}{4}$ W is the Compass Course to steer.

Take another case. Suppose you find from the chart that the Correct Magnetic Course to the place to which you want to go is N 40° E, and you want to find out what Compass Course to steer.

Take two Compass Courses from the Deviation Card, and correct them for Deviation.

Compass Courses	Deviation	Corr. Mag. Course
NE = N 45° E	corrected for 2° 35' E	= N 47° 35' E
NE b N = N 33° 45' E	corrected for 6° 42' E	= N 40° 27' E

Here you have hit so nearly upon the Correct Magnetic Course that no sum in proportion is necessary, and in steering NE b N by Compass, you will be within 1° of the Correct Magnetic Course you require, and goodness knows that is near enough.

Again, suppose you want to find the Compass Course to steer in order to sail S 42° E Correct Magnetic.

Compass Courses	Deviation	Corr. Mag. Course
SSE = S 22° 30' E	corrected for 26° 16' W	= S 48° 46' E
S b E = S 11° 15' E	corrected for 20° 58' W	= S 31° 43' E

The Correct Magnetic Course you require to convert into a Compass Course lies between these two, and a sum in proportion must be done.

48° 46'	42° 0'	26° 16' W
31° 43'	31° 43'	20° 28' W
<u>17° 3'</u>	<u>10° 17'</u>	<u>5° 48' W</u>

Therefore, 17° 3' : 10° 17' :: 5° 48' : x .

Or put for convenience sake decimally,

$$17 : 10.3 :: 5.8 : x$$

Multiply the second and third terms and divide by the first :

$$\begin{array}{r} 10.3 \\ 5.8 \\ \hline 824 \\ 515 \\ \hline 17 \) \ 59.74 \ (\ 3.5 = 3^{\circ} 30' \text{ (the correction required)} \\ \underline{51} \\ 87 \\ \underline{85} \end{array}$$

$$\begin{array}{l} \text{Deviation on S } 31^{\circ} 43' \text{ E (Corr. Mag.)} = 20^{\circ} 28' \text{ W} \\ \text{(Correction)} = + 3^{\circ} 30' \end{array}$$

$$\text{Deviation on S } 42^{\circ} \text{ E (Correct Magnetic)} = \underline{23^{\circ} 58' \text{ W}}$$

$$\begin{array}{l} \text{Correct Magnetic Course S } 42^{\circ} 0' \text{ E} \\ \text{Deviation } 23^{\circ} 58' \text{ W} \\ \hline \text{Compass Course to steer} = \text{S } 18^{\circ} 2' \text{ E} \end{array}$$

Now for Bearings. To turn a True Bearing into a Compass Bearing, first convert True into Correct Magnetic, by applying the Variation, and then apply the Deviation *due to the position of the Ship's Head*. Remember that the Deviation due to the *Bearing* has nothing whatever to do with it. In all these cases you will find it convenient to work with Degrees and parts of a Degree, therefore accustom yourself to turn Points and parts of a Point into Degrees and parts of a Degree.

A TABLE OF THE ANGLES WHICH EVERY POINT AND QUARTER POINT OF THE COMPASS MAKES WITH THE MERIDIAN

North		Points	—			Points	South	
			°	'	"			
		0 — $\frac{1}{4}$	2	48	45	0 — $\frac{1}{4}$		
		0 — $\frac{1}{2}$	5	37	30	0 — $\frac{1}{2}$		
		0 — $\frac{3}{4}$	8	26	15	0 — $\frac{3}{4}$		
N b E	N b W	1	11	15	0	1	S b E	S b W
		1 — $\frac{1}{4}$	14	3	45	1 — $\frac{1}{4}$		
		1 — $\frac{1}{2}$	16	52	30	1 — $\frac{1}{2}$		
		1 — $\frac{3}{4}$	19	41	15	1 — $\frac{3}{4}$		
NNE	NNW	2	22	30	0	2	SSE	SSW
		2 — $\frac{1}{4}$	25	18	45	2 — $\frac{1}{4}$		
		2 — $\frac{1}{2}$	28	7	30	2 — $\frac{1}{2}$		
		2 — $\frac{3}{4}$	30	56	15	2 — $\frac{3}{4}$		
NE b N	NW b N	3	33	45	0	3	SE b S	SW b S
		3 — $\frac{1}{4}$	36	33	45	3 — $\frac{1}{4}$		
		3 — $\frac{1}{2}$	39	22	30	3 — $\frac{1}{2}$		
		3 — $\frac{3}{4}$	42	11	15	3 — $\frac{3}{4}$		
NE	NW	4	45	0	0	4	SE	SW
		4 — $\frac{1}{4}$	47	48	45	4 — $\frac{1}{4}$		
		4 — $\frac{1}{2}$	50	37	30	4 — $\frac{1}{2}$		
		4 — $\frac{3}{4}$	53	26	15	4 — $\frac{3}{4}$		
NE b E	NW b W	5	56	15	0	5	SE b E	SW b W
		5 — $\frac{1}{4}$	59	3	45	5 — $\frac{1}{4}$		
		5 — $\frac{1}{2}$	61	52	30	5 — $\frac{1}{2}$		
		5 — $\frac{3}{4}$	64	41	15	5 — $\frac{3}{4}$		
ENE	WNW	6	67	30	0	6	ESE	WSW
		6 — $\frac{1}{4}$	70	18	45	6 — $\frac{1}{4}$		
		6 — $\frac{1}{2}$	73	7	30	6 — $\frac{1}{2}$		
		6 — $\frac{3}{4}$	75	56	15	6 — $\frac{3}{4}$		
E b N	W b N	7	78	45	0	7	E b S	W b S
		7 — $\frac{1}{4}$	81	33	45	7 — $\frac{1}{4}$		
		7 — $\frac{1}{2}$	84	22	30	7 — $\frac{1}{2}$		
		7 — $\frac{3}{4}$	87	11	15	7 — $\frac{3}{4}$		
East	West	8	90	0	0	8	East	West

The scale upon the preceding page shows you the number of degrees due to any Point, half Point, or quarter Point, and *vice versa*. At sea you have always a Compass with you, with degrees indicated on the Card; all the Epitomes contain Tables giving degrees for points and points for degrees, and the Board of Trade Examiners will provide you with a compass card containing a Table of Angles similar to the one overleaf, so calculation is really unnecessary; but at the same time there is no harm in knowing how to calculate for yourself the number of Degrees contained in any Course given in Points and parts of Points, and the Points and parts of Points equivalent to any number of Degrees.

To turn Points into Degrees, etc.—If you want to express Points in Degrees: as every Point contains $11^{\circ} 15'$, all you have to do is to multiply the Compass Course by $11^{\circ} 15'$. For example, if the Course is $E \frac{3}{4} N$ —that is, $7\frac{1}{4}$ Points from North, or in decimals $7\cdot25$ —this multiplied by $11^{\circ} 15'$, or in decimals $11^{\circ}\cdot25$, will produce the number of Degrees in $E \frac{3}{4} N$. Thus:

$$\begin{array}{rcl}
 E \frac{3}{4} N = 7\frac{1}{4} \text{ Points from North} & = & 7\cdot25 \text{ Points} \\
 11^{\circ} 15' = 11\frac{1}{4} \text{ Degrees} & = & 11\cdot25 \text{ Degrees} \\
 & & \underline{3625} \\
 & & 1450 \\
 & & 725 \\
 & & \underline{725} \\
 & & 81\cdot5625 \text{ Degrees}
 \end{array}$$

But the $\cdot5625$ must be turned into minutes: $\frac{\cdot5625}{60} = 33\cdot7500$ minutes.

There remains $\cdot75$ to be turned into seconds: $\frac{\cdot75}{60} = 45\cdot00$

and $81^{\circ} 33' 45''$ is the arc required. Therefore, $E \frac{3}{4} N$ is equal to $N 81^{\circ} 33' 45'' E$.

To turn Degrees etc. into Points.—Now for the reverse of this problem—namely, to express Degrees in Points.



THIS PAGE IS LOCKED TO FREE MEMBERS

Purchase full membership to immediately unlock this page

DELVE INTO FANTASY, MAGIC, MYTHOLOGY & FOLKLORE

Forgotten Books'
Full Membership gives
access to 797,885 ancient
and modern, fiction and
non-fiction books.

Continue

*Fair usage policy applies

Error is caused by Variation or by Deviation, or by both combined. We will consider the effect of Error from whatever cause it arises.

Consider yourself to be in the middle of the Compass, looking towards its circumference. Suppose the North-seeking end of the Needle to be from some cause or other drawn to the right. The Error will be Easterly. You can see this for yourself. Set the movable Compass Card pointing true North ; suppose the Needle to be deflected two Points to the right, the Error will be two points to the *right*, and the Error is in scientific works called *plus* ; but I presume, because the Error is towards the East when you are looking North, it is commonly called *Easterly Error*. It is called Easterly Error when either end of the Needle is drawn towards your right, even if it is drawn towards the West ; for instance, leave the Compass Card in the same position, and look toward the South. The South-seeking end of the Needle has been drawn towards your right hand, and the Deviation is Easterly, though the South-seeking Pole of the Needle is deflected towards the West. Hence the rule always to be observed is, that when the Needle is drawn to the *right*, Deviation is *Easterly* ; when the Needle is drawn to the *left*, it is *Westerly*.

Another rule never to be forgotten is, that when the *True Bearing* is to the right of the *Compass Bearing*, the Error is Easterly. When it is to the left it is Westerly. This sounds odd in connection with the foregoing rule, but a glance at the Compass Card will show it is true.

Make the North Point of the movable card to coincide with the North Point of the fixed card ; now shift the movable card round two Points to the right : the Needle is now pointing to NNE (True), NNE is to the right of

North, therefore the Error is two Points easterly. Shift the card in any way you like, say till the North-seeking end of the Needle points to WNW. WNW is six Points to the left of North, therefore the Error is six Points Westerly. Now if you look the other way towards the South, the South-seeking end of the Needle will point to ESE (True). ESE is six Points to the *left* of South, and the Error is of course six Points Westerly, although the South-seeking end is actually drawn to the East. The only thing to be absolutely remembered is, that looking from the centre of the Compass towards any part of the circumference, if True Bearing is to the right of the Compass Bearing, Deviation is Easterly; if it is to the left it is Westerly. And if the Needle is drawn to the right of True it gives Easterly Deviation; if it is drawn to the left of True it gives Westerly Deviation.

Supposing you know that with the Ship's Head in a certain direction there is such and such an Error, and you want to find out what Course to steer in order to counteract that error and make the required True Course. Let us imagine you want to steer NE (True), and you know that with the Ship's Head NE you have $1\frac{1}{2}$ Points Westerly Error. Fix the movable card pointing North and South (True), then the Compass NE will of course be pointing NE (True). But the Needle is deflected to the left, because the Error is Westerly $1\frac{1}{2}$ Points. Revolve the Card till the NE Point points to NE b N $\frac{1}{2}$ N; if, therefore, you steer NE by your Compass, you would be steering NE b N $\frac{1}{2}$ N (True), which would not do at all. You would have to steer NE b E $\frac{1}{2}$ E, or $1\frac{1}{2}$ Points to the right of NE by your Compass. Therefore, it is plain that to allow for an Error, if the Error is Westerly, you must steer the amount of Error to the *right* of the Course wanted, as shown on

your Compass. If the Error is Easterly, steer the amount of Error to the *left* of your Compass. Here comes another golden rule in finding what Course to steer. Knowing the True Course and the Error of your Compass, Easterly Error must be allowed for to the Left, Westerly to the Right.

Don't forget these three important facts. 1st, if True is to the right, Error is Easterly; and if True is to the left, Error is Westerly. 2nd, if the needle is deflected to the right of True the Error is Easterly, and if to the left of True the Error is Westerly. 3rd, knowing the Error, steer the amount of it to the left if the Error is Easterly, and to the right if it is Westerly, in order to counteract the Error.

(In the ordinary Masters' Examination it is required that the candidate should be able to ascertain the Correct Magnetic Bearing by taking the Compass Bearings of a distant object with the Ship's Head in the Cardinal and Quadrantal Points, and to draw and understand a Napier's Diagram.)

To Ascertain the Deviation

In order to ascertain the Deviation of your Compass, it is necessary to know how to find the Correct Magnetic Bearing of a distant object at sea, so as to compare it with its bearing by Compass. The following method is usually adopted.

Take the Compass Bearings of an object not less than 5 or 6 miles distant, with the Ship's Head on the four Cardinal and on the four Quadrantal Points by Compass by swinging the ship. If the Bearings are all the same, the Compass has no Deviation. But if they differ, write them down and turn them into degrees. If they are all in the same Quadrant, their sum divided by 8 will give the

Correct Magnetic Bearing of the distant object. For example :

No. 1

Ship's Head by Standard Compass	Bearing of Distant Object by Standard Compass	Ship's Head by Standard Compass	Bearing of Distant Object by Standard Compass
North	N 40° E	South	N 27° E
NE	N 44° E	SW	N 30° E
East	N 38° E	West	N 36° E
SE	N 32° E	NW	N 38° E

Here we have 8 Compass Bearings, all in one Quadrant, and their sum divided by 8 will give us the 'Correct Magnetic' Bearing of the distant object. Thus :

N 40° E	8) 285
N 44° E	<u> </u>
N 38° E	35° and 5° over
N 32° E	<u> </u>
N 27° E	5°
N 30° E	60
N 36° E	<u> </u>
N 38° E	8) 300
<u>285</u>	<u> </u>
	37½

Therefore the Correct Magnetic Bearing is N 35° 38' E.

If the Bearings are not in the same Quadrant, but are all Easterly or all Westerly, while some are North and some are South, see which of the Bearings are the more numerous, those from North or those from South ; change the names of the less numerous Bearings by subtracting each from 180° so as to make all the Bearings of the same name—that is, all from North or from South towards East, or towards West, as the case may be. Add them together, and divide by 8, and the result is the Correct Magnetic Bearing of the distant object. If it is 90° the Correct Magnetic Bearing will be due East or West. If it is more than 90° take it from 180° and change its name from North to South, or *vice versa*.

Thus N 90° E will of course be East, and N 100° E will be S 80° E. Here is an example :

No. 2

Ship's Head by Standard Compass	Compass Bearing Of Distant Object	Ship's Head by Standard Compass	Compass Bearing of Distant Object
North	S 84° W	South	N 79° W
NE	West	SW	N 88° W
East	N 81° W	West	S 83° W
SE	N 76° W	NW	S 79° W

Here we have some of the Bearings in the NW, and some in the SW Quadrants ; of course West is N 90° W or S 90° W, whichever you like. There are more Bearings in the NW Quadrant than in the SW Quadrant, and therefore we will change the SW Bearings into NW.

$$\begin{aligned}
 S\ 84^\circ\ W &= N\ 96^\circ\ W \\
 \text{West} &= N\ 90^\circ\ W \\
 &N\ 81^\circ\ W \\
 &N\ 76^\circ\ W \\
 &N\ 79^\circ\ W \\
 &N\ 88^\circ\ W \\
 S\ 83^\circ\ W &= N\ 97^\circ\ W \\
 S\ 79^\circ\ W &= N\ 101^\circ\ W \\
 &8\)\ \underline{708}
 \end{aligned}$$

Correct Magnetic Bearing = N 88½° W

Take another combination. Suppose all the Bearings are in the Northern or all in the Southern half of the Compass, but some of them are East and some West. In such a case add the Easterly ones together, and add the Westerly ones together ; then take the difference of the sums, and divide it by 8, and name the product East or West according to whether the sum of the Easterly or Westerly Bearings is the greater. The result is the Correct Magnetic Bearing.

Should any of the Compass Bearings be due North or due South, they are to be reckoned as zero in the additions, but the difference is still to be divided by eight. Here is an example :

No. 3

Ship's Head by Standard Compass	Compass Bearing of Distant Object	Ship's Head by Standard Compass	Compass Bearing of Distant Object
North	S 5° E	South	South
NE	S 2° W	SW	S 4° E
East	S 11° W	West	S 10° E
SE	S 6° W	NW	S 9° E

SE Quadrant	SW Quadrant	
S 5° E		S 28° E
S 4° E	S 2° W	S 19° W
S 10° E	S 11° W	
S 9° E	S 6° W	8) S 9° E
<u>S 28° E</u>	<u>S 19° W</u>	<u>S 1° 7' E</u>

Thus the Correct Magnetic Bearing is S 1° 7' E.

To find the Deviation.—Having thus found the Correct Magnetic Bearing of the distant object, the next proceeding is to find the Deviation of your Compass on the eight equidistant positions of the Ship's Head from the observations on which you have derived your Correct Magnetic Bearing.

You can begin where you like. It does not matter. Suppose we begin on North. Write down the Bearing of the object by Compass with the Ship's Head North, and under it write the Correct Magnetic Bearing; the difference is the Deviation with the Ship's Head North by Compass.

If the Compass Bearing and the Correct Magnetic Bearing are both in the same Quadrant, you have only to subtract the less from the greater. Thus, suppose the distant object bore by Compass N 75° E, and the Correct Magnetic Bearing was N 80° E, the difference, namely 5°, is the Deviation. But the Bearings may be in different Quadrants.

Suppose the object bore by Compass N 75° E, and the Correct Magnetic Bearing was S 80° E. Well, from N 75° E to East is 15°, and from East to S 80° E is 10°; in this case you must obviously add them together, and the Deviation is 25°. Or, if you like, take one Bearing from 180° so as to make them both of the same name, and

then take the less from the greater. Thus S 80° E taken from 180° is N 100° E. N 100° E — N 75° E is 25°, which is the Deviation.

But, again, the Bearings may lie on opposite sides of the North or South Points. Suppose the Compass Bearing of the distant object to be N 5° E, and its Correct Magnetic Bearing N 13° W, obviously you must add them together. You have 5° on one side of North, and 13° on the other side, therefore they are 18° apart, and the Deviation is 18°.

To name the Deviation.—Fancy yourself situated in the middle of the Compass Card and looking out to the rim and towards the Bearings; then if the Correct Magnetic is to the right of the Compass, the Deviation is Easterly; if Correct Magnetic is to the left it is Westerly.

Having thus found the Deviation and named it correctly for the Ship's Head North by Compass, proceed to find the Deviations, and name them with the Ship's Head NE, East, SE, South, SW, West, and NW. If you can do one you can do all. It only requires a little care in naming them correctly. Here are the examples given above completed. No. 1 is :

Ship's Head by Standard Compass	Compass Bearing of Distant Object	Correct Magnetic Bearing of Distant Object	Deviation
North	N 40° E	N 35° 38' E	4° 22' W
NE	N 44° E	Do.	8° 22' W
East	N 38° E	Do.	2° 22' W
SE	N 32° E	Do.	3° 38' E
South	N 27° E	Do.	8° 38' E
SW	N 30° E	Do.	5° 38' E
West	N 36° E	Do.	0° 22' W
NW	N 38° E	Do.	2° 22' W

With the Ship's Head North by Compass, the Compass bearing of the distant object was N 40° E, and the Correct Magnetic Bearing N 35° 38' E; the difference, 4° 22', is the Deviation, and it is Westerly, because the Correct



THIS PAGE IS LOCKED TO FREE MEMBERS

Purchase full membership to immediately unlock this page

SAVE \$3,999,994

Did you know we sell
paperback books too?

To buy our entire catalog
in paperback would cost
over \$4,000,000

Access it all now for
\$8.99/month

*Fair usage policy applies

Continue

Napier's Diagram

A Napier's Curve is a most ingenious and useful invention, for which the author deserves the thanks of all those who go down to the sea in ships, and especially of those who go up for examination. It offers the simplest of all methods of turning Compass Courses into Correct Magnetic Courses, or Correct Magnetic Courses into Compass Courses, and of ascertaining the Deviation of the Compass with the Ship's Head in any position.

The principle of Napier's Diagram is very difficult to explain, and I give up the attempt. You have got to imagine as best you can the circular rim of the Compass Card represented as straight.

The diagram consists of a straight line marked North at the top and bottom, and South in the middle, and divided into the thirty-two Points of the Compass. The degrees are given from zero at the top to 90° at East, from 90° at East to zero at South, from zero at South to 90° at West, and from 90° at West to zero at North at the bottom. Lines are drawn forming an angle of 60° with the medial line of the Diagram, and intersecting each other at every Compass Point. The right-hand side of the medial line is East, the left-hand side is West. The lines drawn from right to left downwards are plain, those from left to right are dotted. A glance at the accompanying diagram (fig. 2) will show this at once.

To draw a curve of Deviation.—In practice you would of course have first to find the Deviation on the four Cardinal and the four Quadrantal Points; but these will be given you at the Board of Trade Examination.

With a pair of dividers measure anywhere on the medial line the Deviation with the Ship's Head North; then, if the Deviation is Easterly, measure it on the *dotted*

FIG. 2.

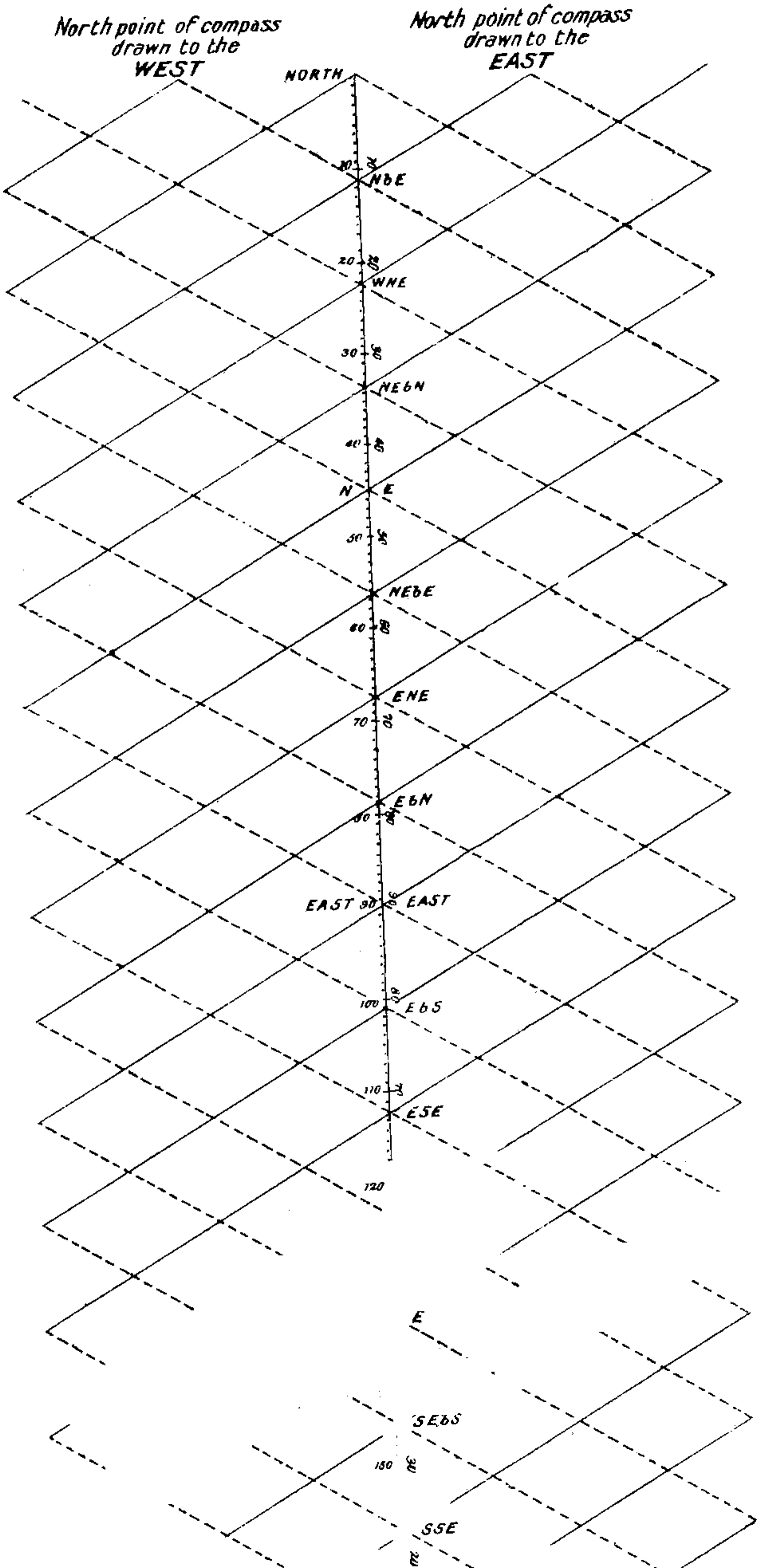



THIS PAGE IS LOCKED TO FREE MEMBERS

Purchase full membership to immediately unlock this page

DELVE INTO FANTASY, MAGIC, MYTHOLOGY & FOLKLORE

Forgotten Books'
Full Membership gives
access to 797,885 ancient
and modern, fiction and
non-fiction books.

Continue

*Fair usage policy applies

line from North to the right, and mark the spot on the diagram. Proceed to deal in the same way with the Deviation for the Ship's Head on NE, East, SE, South, SW, West, and NW back to North again : all you have to do in each case is to measure the Deviation with a pair of dividers anywhere on the medial line, marking it off on a *dotted* line to the *right* if it is *Easterly*, to the left if it is *Westerly* Deviation. The *Easterly* Deviations will be all *downwards*, and the *Westerly* Deviations all *upwards*. Having measured and marked the Deviation for the Cardinal and Quadrantal Points, you will have nine dots upon the diagram. Through these draw a curve with a pencil, fairing it nicely with the eye, and then draw it in with ink. This curved line represents the Deviation of the Compass with the Ship's Head on every Point, half or quarter Point, or degree. So much for drawing the curve; now to use it.

Use of Napier's Curve.—The curve can be used for four purposes. 1st, to find the Deviation with the Ship's Head on any degree by Compass. 2nd, to find the Deviation with the Ship's Head on any degree Correct Magnetic. 3rd, to turn any Compass Course into a Correct Magnetic Course. 4th, to turn any Correct Magnetic Course into a Compass Course.

If you want to know the Deviation of the Compass with the Ship's Head on any degree by *Compass* : from that degree and along a *dotted* line if a dotted line passes through it—or if no dotted line passes through it, then parallel to the nearest *dotted* line—measure the distance to the curve with a pair of dividers ; measure this distance off on the medial line, and that gives you the Deviation required : it is East if the curve is to the right of the medial line, West if it is to the left of the medial line.

If you want to know the Deviation with the Ship's Head *Correct Magnetic* instead of by Compass, measure from

the medial line out to the curve along a *plain* line instead of along a dotted one, and proceed as in the former case.

If you want to turn a Compass Course into a Correct Magnetic Course: Place the point of one leg of your dividers upon the Compass Course on the medial line and measure out to the curve along a *dotted* line; or if that is impossible, then parallel to the nearest dotted line and, keeping the point of the dividers down on the curve, measure back again to the medial line along or parallel to the nearest *plain* line; the Course indicated on the medial line will be the Correct Magnetic Course required.

On the other hand, if you want to find the Compass Course to steer in order to make good a Correct Magnetic Course, measure out in the same way along or parallel to a *plain* line, and back along or parallel to a *dotted* line.

This is not difficult to remember, but the following doggerel lines may help :

From Compass Course Magnetic Course to gain,
Go out by dotted, back again by plain ;
But if you want to steer a course allotted,
Go out by plain and back again by dotted.

If your courses are given you in Points and parts of a Point the most accurate plan is to turn them into degrees and proceed as above. But to avoid trouble and save time you can use Points and half and quarter Points by judging where they start from on the medial line. The Points only are written on the medial line, so you must estimate the position of the half and quarter Points.

You will be required in the Board of Trade Examination to draw a Napier's Curve, the Diagram being furnished to you, and the Deviations on eight Points. You will be required to turn three or four Compass Courses into Correct Magnetic Courses, and three or four Correct Magnetic into Compass Courses. And you will be



THIS PAGE IS LOCKED TO FREE MEMBERS

Purchase full membership to immediately unlock this page

SAVE \$3,999,994

Did you know we sell
paperback books too?

To buy our entire catalog
in paperback would cost
over \$4,000,000

Access it all now for
\$8.99/month

*Fair usage policy applies

Continue

(b) Having found the Deviations, strike off the curve on a Napier's Diagram (see No. 1 Curve, fig. 3).

(c) With the Deviations as above, give the Course you would steer by the Standard Compass to make good the following Correct Magnetic Courses.

Correct Magnetic Courses	<u>N 28° E</u>	<u>S 3° W</u>	<u>S 87° E</u>	<u>N 57° W</u>
Corresponding Standard Compass Courses	} N 22° E	} S 8° W	} S 69½° E	} N 71° W

The Compass Courses are arrived at thus. From the point N 28° E on the medial line of the diagram go out, with your dividers parallel to the plain lines, to the curve, and come back, parallel to the dotted lines, to the medial line. You will reach the medial line at N 22° E, which is the Standard Compass Course. Proceed in the same way to deal with the other Magnetic Courses. (The lines by which you go out and come back are marked on the diagram.)

(d) With the Deviations as above, give the Correct Magnetic Courses due to the following Standard Compass Courses you have steered.

Standard Compass Courses	<u>W b N ½ N</u>	<u>SW ¾ W</u>	<u>SSE</u>	<u>NE ½ E</u>
Correct Magnetic Courses	N 59° W	S 63½° W	S 39° E	N 50° E

Find the point W b N ½ N on the medial line of the diagram. With your dividers go out to meet the curve from this point along the dotted line, and come back parallel to the plain lines, and you arrive at 301°, that is, 360° - 59°, or N 59° W. Proceed in the same way for the other Courses. (The lines marked in the diagram indicate clearly the method.)

(e) The Ship's Head being SE ½ E by Standard Compass, find the Correct Magnetic Bearings of two objects which bore by Standard Compass S b E ¼ E and SW ¾ W respectively.



THIS PAGE IS LOCKED TO FREE MEMBERS

Purchase full membership to immediately unlock this page

DELVE INTO FANTASY, MAGIC, MYTHOLOGY & FOLKLORE

Forgotten Books'
Full Membership gives
access to 797,885 ancient
and modern, fiction and
non-fiction books.

Continue

*Fair usage policy applies

(b) Having found the Deviations, strike off the curve on a Napier's Diagram (see No. 2 Curve, fig. 4).

(c) With the Deviation as above, give the Courses you would steer by the Standard Compass to make good the following Courses Correct Magnetic.

Correct Magnetic Courses	<u>N 60° E</u>	<u>W b S</u>	<u>S 20° E</u>	<u>N ½ W</u>
Standard Compass Courses	N 47° E	N 78° W	SE b S	N 4° E

(The way the Courses are obtained is shown in the diagram.)

(d) With the Deviations as above, give the Correct Magnetic Courses due to the following Standard Compass Courses you have steered.

Standard Compass Courses	<u>NW b W</u>	<u>S ¾ W</u>	<u>E b N ½ N</u>	<u>SE b S</u>
Correct Magnetic Courses	N 84° W	S 20° W	East	S 20° E

(The working of these is shown in the Napier Diagram.)

(e) The Ship's Head being NW ½ W by Standard Compass, find the Correct Magnetic Bearings of two objects which bore by Standard Compass NNW ½ W and W b S ¼ S respectively.

Deviation, Ship's Head being NW ½ W by Standard Compass, is found by the curve to be 29° W.

Standard Compass Bearing NNW ½ W	= N 28° W
Deviation	= 29° W
Correct Magnetic Bearing	= <u>N 57° W</u>

Standard Compass Bearing W b S ¼ S	= S 76° W
Deviation	= 29° W
Correct Magnetic Bearing	= <u>S 47° W</u>

3 (a) In the following Table give the Correct Magnetic Bearing of the distant object, and thence the Deviations.



THIS PAGE IS LOCKED TO FREE MEMBERS

Purchase full membership to immediately unlock this page

SAVE \$3,999,994

Did you know we sell
paperback books too?

To buy our entire catalog
in paperback would cost
over \$4,000,000

Access it all now for
\$8.99/month

*Fair usage policy applies

Continue

Ship's Head by Standard Compass	Bearing of Distant Object by Standard Compass	Deviation	Ship's Head by Standard Compass	Bearing of Distant Object by Standard Compass	Deviation
North	N 9° E	7° W	South	N 6½° W	8½° E
NE	N 17° E	15° W	SW	N 25° W	27° E
East	N 24½° E	22½° W	West	N 18½° W	20½° E
SE	N 17° E	15° W	NW	N 1½° W	3½° E

Writing the Bearings by Standard Compass in the 8 positions of the Ship's Head as shown; adding the four which are in the NE quadrant, and also the four in the NW quadrant, subtracting the sum of the latter from the former, we find that the Correct Magnetic Bearing of Distant Object is N 2° E.

NE Quadrant	NW Quadrant
N 9° E	N 6½° W
17°	25°
24½°	18½°
17°	1½°
-----	-----
67½°	51½°
51½°	

8) 16°	
N 2° E	

Ship's Head	North	NE	East	SE
Correct Magnetic Bearing	N 2° E	N 2° E	N 2° E	N 2° E
Compass Bearing . . .	N 9° E	N 17° E	N 24½° E	N 17° E
Deviation	7° W	15° W	22½° W	15° W
Correct Magnetic Bearing	South N 2° E	SW N 2° E	West N 2° E	NW N 2° E
Compass Bearing . . .	N 6½° W	N 25° W	N 18½° W	N 1½° W
Deviation	8½° E	27° E	20½° E	3½° E

(b) Having found the Deviations, strike off the curve on a Napier's Diagram (see No. 3 Curve, fig. 5).

(c) With the Deviations as above, give the Course you would steer by the Standard Compass to make good the following Courses Correct Magnetic.

Correct Magnetic Courses	N 80° E	South	S 85° W	N 4° W
Corresponding Standard Compass Courses	S 78° E	S 5° E	S 59° W	N 4° E

(The diagram shows how these results are obtained.)

(d) With the Deviations as above, give the Correct Magnetic Courses due to the following Standard Compass Courses you have steered.

Standard Compass Courses	<u>NE</u>	<u>SE $\frac{1}{2}$ S</u>	<u>W b S $\frac{1}{4}$ S</u>	<u>NW b N $\frac{1}{2}$ N</u>
Correct Magnetic Courses	N 30° E	S 52° E	N 80° W	N 28° W

(The diagram shows how these results are obtained.)

(e) The Ship's Head being NW b W $\frac{1}{2}$ W by Standard Compass, find the Correct Magnetic Bearings of two objects which bore by Standard Compass NE $\frac{1}{2}$ E and N W $\frac{1}{4}$ W respectively.

Deviation with the Ship's Head NW b W $\frac{1}{2}$ W by Standard Compass is 10° E.

Standard Compass Bearings	NE $\frac{1}{2}$ E = N 50 $\frac{1}{2}$ ° E,	and	NW $\frac{1}{4}$ W = N 48° W
	Deviation		10° E
			<u>10° E</u>
Correct Magnetic Bearings	N 60 $\frac{1}{2}$ ° E	and	<u>N 38° W</u>



THIS PAGE IS LOCKED TO FREE MEMBERS

Purchase full membership to immediately unlock this page

DELVE INTO FANTASY, MAGIC, MYTHOLOGY & FOLKLORE

Forgotten Books'
Full Membership gives
access to 797,885 ancient
and modern, fiction and
non-fiction books.

Continue

*Fair usage policy applies

Courses taken from the bottom—that is, from 4 Points to $7\frac{3}{4}$ Points inclusive—Departure lies next to the Distance column, and Difference of Latitude to the right of Departure.

Table II. is precisely the same, except that the Course is given in degrees, from 1° to 45° at the top, and from 45° to 89° at the bottom, and Distance is given up to 600 miles. It is much more convenient to use Degrees than Points, and students should accustom themselves to Table II.

To use the Tables.—*From a known Course and Distance, to find the Difference of Latitude and Departure.*—Look out the Course at the top or bottom of the page, and the Distance in a Distance column, and alongside of it you will find the Difference of Latitude and Departure.

From a known Difference of Latitude and Departure, to find a Course and Distance.—Search in the Difference of Latitude and Departure columns, until you find alongside of each other your Difference of Latitude and Departure; alongside of them the Distance is given, and the Course at the top or bottom of the page, as the case may be. If you can't find your exact Difference of Latitude and Departure, take the two figures which agree most nearly with them. Difference of Latitude and Departure being given in minutes and decimals of a minute, if you multiply the decimal part by 6 you will have the seconds of Difference of Latitude, or Departure.

Other combinations may arise—for instance, you might know your Course and Difference of Latitude, and might want to know your Distance and Departure. It is sufficient to say that in dealing with Courses, Distance, Difference of Latitude, and Departure, if you know any two of them you can find the others by the Traverse Table.

Table XXV.—In Table XXV. take no notice at present of the first few pages headed ‘Log. Sines to Seconds of Arc,’ but commence with the page headed ‘Log. Sines, Cosines, &c.’ In this Table degrees are given from 0° to 44° at the top, and from 45° to 89° at the bottom.

The ratios are given at the top in the following order, starting from the left: Sine, Cosecant, Tangent, Cotangent, Secant, Cosine; and they are given at the bottom in the same order, but from the right: Sine, Cosecant, Tangent, Cotangent, Secant, Cosine. Thus it will be seen that the Log. of any Sine between 0° and 45° is the Log. of a Cosine between 45° and 89° , and so on with every other ratio. Degrees are given at the top or bottom of the page; minutes and half-minutes in a column on the left-hand side of the page from 0° to 45° , and on the right-hand side of the page from 45° to 89° .

Suppose you want to find the Log. Sine of $21^\circ 5\frac{1}{2}'$. Look out 21° at the top of the page, follow down the minute column till you come to $5\frac{1}{2}$, then to the right of it in the column headed ‘Sine’ you will find the Log. you want, and following on the line to the right you will find the Cosecant, Tangent, Cotangent, Secant, and Cosine should you want them. The same Logs. will represent the Sine, Cosecant, Tangent, Cotangent, Secant, Cosine, of $68^\circ 54\frac{1}{2}'$.

Now suppose you want to find the ratios of an angle containing an odd number of seconds—say, for instance, the angle $21^\circ 5' 38''$ —and let us assume you want the Log. Sine. The Log. Sine of $21^\circ 5\frac{1}{2}'$ is 9.556135. Between the columns of Sines and Cosecants you will find a column headed ‘Parts for seconds.’ Look for the odd number of seconds—8—and you will find that 44 parts are due to it. These 44 parts are to be applied to the Log. Sine of

$21^{\circ} 5' 30''$. $9.556135 + 44 = 9.556179 =$ the Log. Sine required.

Proceed in the same way to find the Log. of any other ratio, Cosecant, Tangent, Cotangent, Secant, or Cosine. Remember that the 'parts for' are always to be *added* to Log. Sines, Tangents, and Secants, because these Logs. increase as the angles increase; they are always to be *deducted* from all the Log. Cosines, Cotangents, Cosecants, because these Logs. decrease as the angles increase.

If the 'parts for' are large, and you cannot mentally add or deduct them from the Log., the best plan is to commence writing the Log. down from the right, instead of from the left, and add or deduct them as you go along; or if you prefer it, you can, in working any problem, write down the 'parts for' separately, marking them + or -, and then, having added your Logs. together, allow for the balance of the 'parts for.' Thus, supposing you wanted to add together the Log. Secant of $68^{\circ} 30' 12''$, the Log. Cosecant of $21^{\circ} 22' 13''$, Log. Cosine of $72^{\circ} 39' 11''$, and Log. Sine of $15^{\circ} 8' 14''$, you might write them down thus :

$68^{\circ} 30' 0''$	Log. Sec	10.435925		
	12'' 'parts for'		+ 65	
$21^{\circ} 22' 0''$	Log. Cosec	10.438499		
	13'' 'parts for'		- 70	
$72^{\circ} 39' 00''$	Log. Cos	9.474519		
	11'' 'parts for'		- 74	
$15^{\circ} 8' 0''$	Log. Sin	9.416751		
	14'' 'parts for'		+ 109	
		9.765694	+ 174	- 144
		+ 30		+ 174
		9.765724		+ 30

This is a somewhat cumbrous process, and will soon be dispensed with as you become familiar with the Tables. In a very short time you will be able easily to write the Logs. down, commencing at the right, and adding or subtracting the 'parts for' as you go along if they are large ;



THIS PAGE IS LOCKED TO FREE MEMBERS

Purchase full membership to immediately unlock this page

SAVE \$3,999,994

Did you know we sell
paperback books too?

To buy our entire catalog
in paperback would cost
over \$4,000,000

Access it all now for
\$8.99/month

*Fair usage policy applies

Continue

the Log. Tangent of $3^{\circ} 31' 14''$ must lie between the Log. Tangents of $3^{\circ} 31'$ and $3^{\circ} 31' 30''$. Now we will proceed to 'the Sailings.'

Plane Sailing

In the Sailings the angles and sides of the triangles consist of Courses, Distances, Differences of Latitude, and Departures.

A Course is the angle which a ship's track through the water makes with the Meridians or True North and South lines.

A Distance is the number of nautical miles that a ship travels in a given time, or it is the length from one place to another in nautical miles.

Difference of Latitude is the difference between the Latitude of two places, or the distance in nautical miles North or South between two places, or it is the number of nautical miles that your ship sails North or South in a given time.

Difference of Longitude is the difference between the Longitude of any two places, or it is the distance which your ship travels East or West in any given time, measured in Longitude; but remember that this is never the same thing as the distance sailed East or West expressed in nautical miles except on the Equator, because as the Meridians approach each other till they meet at the Poles, the distance in a degree of Longitude gradually decreases from 60 miles at the Equator, to nothing at the Poles.

The Distance which a ship sails East or West in nautical miles and parts of a mile is called her 'Departure.'

If a ship were to sail due North or South she would

make no Departure, and the Distance she sails is the Difference of Latitude she makes.

If she sails due East or West, she makes no Difference of Latitude, and the Distance she sails is her Departure.

If she sails in any direction other than due North, South, East or West, she makes both Difference of Latitude and Departure. In such a case you would know your Course and Distance by Dead Reckoning, and the Plane Sailing Problem would be to find the Difference of Latitude and Departure due to that Course and Distance.

To find the Difference of Latitude.—Add together the Log. of the Distance and the Log. Cosine of the Course; the result (rejecting tens in the Index) is the Log. of the Difference of Latitude.

To find the Departure.—Add together the Log. of the Distance and the Log. Sine of the Course, and the result (rejecting tens in the Index) is the Log. of the Departure.

Here follow a few examples of finding the Difference of Latitude and Departure from a given Course and Distance.

1. A ship sails N 48° E, 119 miles: find the Difference of Latitude and Departure she has made.

Distance 119 miles Log.	2·075547	119 Log.	. 2·075547
Course 48° Log. Cos	<u>9·825511</u>	48° Log. Sin	<u>9·871073</u>
Diff. Lat. Log.	1·901058	Dep. Log.	. 1·946620
Diff. Lat. =	<u>79·63 N</u>	Dep. =	<u>88·43 E</u>

2. A ship sails S 81° E, 98 miles: find the Difference of Latitude and Departure she has made.

Distance 98 miles Log.	1·991226	98 Log.	. 1·991226
Course 81° Log. Cos	<u>9·194332</u>	81° Log. Sin	<u>9·994620</u>
Diff. Lat. Log.	1·185558	Dep. Log.	. 1·985846
Diff. Lat. =	<u>15·33 S</u>	Dep. =	<u>96·79 E</u>

3. A ship sails N 11° W, 3728 miles : find the Difference of Latitude and Departure she has made.

Distance 3728 miles Log. 3.571476	3728 Log. . 3.571476
Course 11° Log. Cos <u>9.991947</u>	11° Log. Sin <u>9.280599</u>
Diff. Lat. Log. 3.563423	Dep. Log. . 2.852075
Diff. Lat. = <u>3659 N</u>	Dep. = <u>711.3 W</u>

These problems can also be solved by the use of the Traverse Table.

Enter Table I. if your Course is in Points, or enter Table II. if it is in degrees, and opposite your Distance in the Distance column you will find your Difference of Latitude and Departure in the columns marked Lat. and Dep.

In Example 1.—A ship sails N 48° E, 119 miles.

In the Traverse Table II. with 48° at the bottom and 119 in the Distance column, you will find 79.6 in the Difference of Latitude column, and 88.4 in the Departure column ; and the Difference of Latitude is 79.6 miles N, and the departure is 88.4 miles E.

In Example 2.—A ship sails S 81° E, 98 miles.

In the Traverse Table with 81° at the bottom and 98 in the Distance column, we have 15.3 in the Difference of Latitude column, and 96.8 in the Departure column ; and the Difference of Latitude is 15.3 miles S, and the Departure 96.8 miles E.

In Example 3.—A ship sails N 11° W, 3728 miles.

In the Traverse Table with 11° at the top, we find the Distances are only given to 600 miles. To bring 3728 within this limit we must divide it by some number that will, if possible, bring out an even result, and 8 is a suitable number. $3728 \div 8 = 466$. Now 466 in the Distance column gives us 457.4 in the Difference of Latitude column, and 88.9 in the Departure column. As



THIS PAGE IS LOCKED TO FREE MEMBERS

Purchase full membership to immediately unlock this page

DELVE INTO FANTASY, MAGIC, MYTHOLOGY & FOLKLORE

Forgotten Books'
Full Membership gives
access to 797,885 ancient
and modern, fiction and
non-fiction books.

Continue

*Fair usage policy applies

Here are a few examples in Parallel Sailing.

1. A ship in Latitude 52° N. sails 79 miles due East; what Difference of Longitude has she made?

$$\begin{array}{r} \text{Lat. } 52^{\circ} \text{ Log. Sec } 10\cdot210658 \\ \text{Dep. } 79 \text{ Log. } \quad \quad \quad \underline{1\cdot897627} \\ \text{Diff. Long. Log. } 2\cdot108285 \\ \text{Diff. Long.} = 128\cdot3 \text{ East} = 2^{\circ} 8' 18'' \text{ E} \end{array}$$

2. A ship in Latitude $37^{\circ} 15'$ S and Longitude $17^{\circ} 28' \text{ W}$ sails due West 118 miles. Required her present position.

$$\begin{array}{r} \text{Lat. } 37^{\circ} 15' \text{ Log. Sec } 10\cdot099086 \\ \text{Dep. } 118 \text{ Log. } \quad \quad \quad \underline{2\cdot071882} \\ \text{Diff. Long. Log. } 2\cdot170968 \\ \text{Diff. Long.} = 148\cdot2' = 2^{\circ} 28' 12'' \text{ W} \end{array}$$

$$\begin{array}{r} \text{Longitude left} \quad \quad \quad \cdot \quad 17^{\circ} 28' 0'' \text{ W} \\ \text{Diff. Long.} \quad \quad \quad \cdot \quad \quad \quad \underline{2^{\circ} 28' 12'' \text{ W}} \\ \text{Longitude in} \quad \quad \quad \cdot \quad \underline{19^{\circ} 56' 12'' \text{ W}} \\ \text{and Latitude in} \quad \quad \quad \underline{37^{\circ} 15' 0'' \text{ S}} \end{array} \left. \vphantom{\begin{array}{r} \text{Longitude left} \\ \text{Diff. Long.} \\ \text{Longitude in} \\ \text{and Latitude in} \end{array}} \right\} \text{Ship's Position}$$

This Problem can be worked by the Traverse Table, thus. With Latitude as a Course, look for the Departure in the Difference of Latitude column, and you will find the Difference of Longitude in the Distance column.

Suppose the Problem is : *To find the Distance between two places situated on the same Parallel of Latitude, the Longitude of each of them being known.* Use the following formula :

To the Log. Cosine of the Latitude add the Log. of the Difference of Longitude : the result is the Log. of the Departure ; the Departure is the Distance required.

To work this by the Traverse Tables. With Latitude as a Course and Difference of Longitude in the Distance column, you will find the Departure in the Difference of Latitude column, and the Departure is the Distance.

Be it noted that to find the Log. of a degree or number of degrees either of Difference of Longitude or Difference

of Latitude, it or they must be turned into minutes by multiplying them by 60.

Find the Distance from A to B, both being situated on the Parallel of 52° N Lat. ; the Longitude of A being 62° W, and that of B $84^{\circ} 29'$ W.

$$\begin{array}{r}
 \text{Longitude of A} = 62^{\circ} 0' \text{ W} \\
 \text{,, ,, B} = 84^{\circ} 29' \text{ W} \\
 \hline
 \text{Diff. Long.} = 22^{\circ} 29' \text{ W} \\
 \quad \quad \quad 60 \\
 \hline
 \text{,, ,,} \quad \quad 1349' \text{ W} \\
 \\
 \text{Diff. Long.} = 1349' \quad \text{Log.} \quad . \quad 3.130012 \\
 \text{Lat.} \quad \quad = 52^{\circ} 0' 0'' \quad \text{Log. Cos.} \quad . \quad 9.789342 \\
 \quad \quad \quad \quad \quad \quad \quad \quad \text{Dep. Log.} \quad 2.919354
 \end{array}$$

Departure or Distance = 830.5 miles, very nearly

Parallel Sailing is included in the examination for Second Mate.

Middle Latitude Sailing

Middle Latitude Sailing is exactly the same as Parallel Sailing, except that for the purpose of finding your Difference of Longitude from the Departure you assume that the Departure has been made on your Middle Latitude as a Parallel.

The Problem is: *To find the Course and Distance between two places, the Latitudes and Longitudes of which are known.*

Find the Difference of Latitude between the two places, and also the Difference of Longitude. Add the two Latitudes together and divide by two for the Middle Latitude. Turn the Difference of Longitude into minutes.

Then 1st. To the Log. Cosine of the Middle Latitude add the Log. of the Difference of Longitude; the result (rejecting ten in the Index) is the Log. of the Departure.

2nd. From the Log. of the Departure (with ten added to the Index) take the Log. of the Difference of Latitude; the remainder is the Log. Tangent of the Course.

3rd. To the Log. Secant of the Course add the Log. of the Difference of Latitude; the sum (rejecting ten in the Index) is the Log. of the Distance.

By the Traverse Table. 1st. With the Middle Latitude as a Course and the Difference of Longitude, turned into minutes, in the Distance Column, you will find the Departure in the Difference of Latitude column. 2nd. With this Departure and the proper Difference of Latitude, take out the corresponding Course and Distance. Here are some examples:

1. Find—(a) by Logs., (b) by inspection—the Course and Distance from A to B by Middle Latitude Sailing.

Lat. A .	49° 18' N	Long. A .	7° 18' W	Lat. A .	49° 18' N
Lat. B .	45° 38' N	Long. B .	12° 2' W	Lat. B .	45° 38' N
	3° 40'		4° 44'		2) 94° 56'
	60		60		Middle Lat. = 47° 28'
Diff. Lat.	220 S	Diff. Long.	284 W		

(a) Mid. Lat. .	47° 28'	Log. Cos	9·829959
Diff. Long.	284'	Log.	2·453318
Dep. .	191·8 miles =	Log.	12·283277
Diff. Lat. .	220'	Log.	2·342423
Course .	41° 6' 38'' =	Log. Tan	9·940854
Course .		Log. Sec	10·122950
Diff. Lat. .		Log.	2·342423
Dist. .	292 miles =	Log.	12·465373

or (b) As 47° 28' is practically halfway between 47° and 48° the Departures must be averaged from these.

With 47° as a Course and 284 as a Distance, the Traverse Table gives 193·7 in the Diff. Lat. column.

With 48° as a Course and 284 as a Distance, the same Table gives 190·0 in the Diff. Lat. column.

$$\begin{array}{r} 193\cdot7 \\ 190\cdot0 \\ \hline 2) 383\cdot7 \end{array}$$

$$\text{Departure} = 191\cdot8$$

Next, with Diff. Lat. 220' and Dep. 191·8', find the corresponding Course and Distance in the Traverse Table.

On p. 98 you will find 220·4 in the Diff. Lat. column, and 191·6 in the Dep. column. This is near enough. Take out the Course and Distance. It is S 41° W, 292 miles.

As all these problems should be worked by the



THIS PAGE IS LOCKED TO FREE MEMBERS

Purchase full membership to immediately unlock this page

SAVE \$3,999,994

Did you know we sell
paperback books too?

To buy our entire catalog
in paperback would cost
over \$4,000,000

Access it all now for
\$8.99/month

*Fair usage policy applies

Continue

and Longitudes of two places, you want to find the Course and Distance between them ; in most cases this can be better done by Mercator's Sailing, which we will take next. A problem in Mercator's Sailing is given in the Board of Trade Examination, whereas no Middle Latitude problem is given.

Mercator's Sailing

The most useful case that occurs in Mercator's Sailing, and the one which will be given in the Board of Trade Examination, is that mentioned in Middle Latitude Sailing, namely : Given the Latitudes and Longitudes of two places, required to find the Course and Distance between them. This is a useful problem, as by its means you will generally find the bearing and distance from you of the nearest point of land when you are approaching a coast.

All Charts commonly used in Navigation are constructed on what is called Mercator's Projection. The earth's surface is treated as if it were flat. The Meridians are drawn parallel to each other, and to get over the consequent geographical inaccuracy the distances between the Parallels of Latitude are increased in proportion to the exaggerated distance of the Meridians from one another. In fact, as the distance between the Meridians is too great, the distance between the Parallels is made too great. This is a very rough-and-ready description of Mercator's Projection, which is more fully explained on page 216, but what I have here said is sufficient to indicate the existence of and necessity for what are called 'Meridional Parts.' As the Parallels are drawn too far apart, the artificial distance between them must be

rectified, and this is done by using the Meridional Parts tabulated in Table III. Now to proceed.

The Latitude and Longitude of two places being known, required to find the Course and Distance between them.

Find the difference between the two Latitudes, and turn it into minutes. This *Difference* is the difference between them if they are of the same name, both North or both South, but is their sum if they are of different names. Name the Difference North or South according to whether you have to go North or South in sailing from one place to another.

Take out from Table III. the Meridional parts due to each Latitude, and treat them precisely as you have treated the Latitudes, taking their difference or sum as the case may be, and call this the Meridional Difference of Latitude, or Mer. Diff. Lat.

Find the difference between the two Longitudes, and name it East or West as the case requires.

Take out the Logs. of the Difference of Longitude, of the true Difference of Latitude, and of the Meridional Difference of Latitude from Table XXIV.

Then from the Log. of the Difference of Longitude (with 10 added to the Index) take the Log. of the Meridional Difference of Latitude. The result is the Log. Tangent of the Course.

Look out this Log. Tangent in Table XXV., and you will find the True Course, at the top of the page if your Tangent is taken from the top, at the bottom of the page if your Tangent is taken from the bottom. Name the Course N or S according to whether the true Difference of Latitude is North or South, and towards East or West according to whether the Difference of Longitude is towards the East or West.

Run your finger along, from the Log. Tangent which you have got, to the Log. Secant, and take that out.

To this Log. Secant add the Log. of the true Difference of Latitude, and the result is the Log. of the Distance. Look this Log. out in Table XXIV. and take out the natural number belonging to it, which is the Distance required.

Here are a couple of examples:

1. Find by Mercator's Sailing the Course and Distance from Vancouver to Yokohama.

	Latitude	Meridional Parts	Longitude
Vancouver	50° 42·6' N	3541	127° 25' W
Yokohama	35° 26·4' N	2276	139° 39·2' E
	<u>15° 16·2'</u>	Mer. Diff. Lat. 1265	<u>267° 4·2' E</u>
	60		<u>360° 0'</u>
Diff. Lat.	916·2' S		<u>92° 55·8' W</u>
			60
			Diff. Long. <u>5575·8' W</u>
Diff. Long.	. . . 5575·8	Log. . . .	13·746307
Mer. Diff. Lat.	. . . 1265	Log. . . .	<u>3·102090</u>
		Course S 77° 13' W	Log. Tan 10·644217
Course 77° 13' 0''	Log. Sec. . . .	10·655088
Diff. Lat. 916·2	Log. . . .	<u>2·961990</u>
		Distance 4141 = Log.	<u>3·617078</u>

The answer is Course S 77° 13' W Dist. 4141 miles.

2. Find by Mercator's Sailing the Course and Distance from the Cape of Good Hope to Cape Grim, Tasmania. We will work this to the greatest degree of exactitude.

	Latitude	Meridional Parts	Longitude
Cape of Good Hope	34° 21·2' S	2197	18° 29·5' E
Cape Grim . . .	<u>40° 40' S</u>	<u>2675</u>	<u>144° 40·7' E</u>
	6° 18·8'	Mer. Diff. Lat. 478	<u>126° 11·2'</u>
	<u>60</u>		<u>60</u>
Diff. Lat. =	378·8' S		Diff. Long. <u>7571·2' E</u>
Diff. Long.	. . . 7571·2'	Log. . . .	13·879164
Mer. Diff. Lat.	. . . 478	Log. . . .	<u>2·679428</u>
		Course Log. Tan	11·199736
		86° 23' Log. Tan	<u>11·199237</u> nearest Log.
		Diff.	499



THIS PAGE IS LOCKED TO FREE MEMBERS

Purchase full membership to immediately unlock this page

DELVE INTO FANTASY, MAGIC, MYTHOLOGY & FOLKLORE

Forgotten Books'
Full Membership gives
access to 797,885 ancient
and modern, fiction and
non-fiction books.

Continue

*Fair usage policy applies

(3) to find one Course and Distance from this Difference of Latitude and Departure. This is called Traverse Sailing.

The final steps consist of turning Departure into Difference of Longitude, and by applying the Difference of Latitude and Difference of Longitude made in twenty-four hours to the Latitude and Longitude you were in at the previous Noon, to fix the position of the Ship at Noon by Dead Reckoning. The entire process is called 'A Day's Work.'

Of course, you may only want to find what Course and Distance you have made good, and consequently what Difference of Latitude and Difference of Longitude you have made during a period of time less than twenty-four hours; and you may want to know what change has taken place in your ship's position, in reference to a position ascertained by the distance and bearing of an object on shore, the Latitude and Longitude of which is known to you. In the Board of Trade Examination the Day's Work problem will probably present itself in the shape of giving you the Distance and Bearing of some object on shore from which you take your Departure, and requiring you to find your position at the next Noon by Traverse Sailing, and we will consider the problem from that point of view.

Traverse Sailing is worked by means of a Traverse form, in which you enter the various Courses and the Distances sailed on them, and the accuracy of the result depends upon the accuracy with which the Courses steered and Distances sailed on them are kept, and on your making proper allowance for Leeway, the action of currents, and for Deviation and Variation.

True Courses are used, and the Distance appropriate to each; the effect of current or tide is allowed

for separately as a Course and Distance; and the bearing and distance of the object on shore from which you take your departure is treated as a Course and Distance.

Draw a Traverse form as below—in the Board of Trade Examination it will be given you printed on the paper containing the problem.

Courses	Distance	North	South	East	West

In the Courses and Distance columns write down your *True* Courses, and the Distance sailed on each of them. In the North, South, East, and West columns write down the Difference of Latitude and Departure due to each Course and Distance as ascertained from the Traverse Table II. Add together all the Differences of Latitude North. Add together all the Differences of Latitude South. Find the difference between the sum of the Difference of Latitude North and the sum of the

Difference of Latitude South, and name it of the same name as the greater of the two. This difference is the Difference of Latitude North or South as the case may be, due to the whole of your Courses.

Add together all the Departures East. Add together all the Departures West. Find the difference between the sum of the Departures East and the sum of the Departures West, and name it of the same name as the greater of the two. This difference is the Departure East or West as the case may be, due to all your Courses.

You have now one Difference of Latitude and one Departure; look for them in Table II. until you find them together. (If no Difference of Latitude and Departure in the Table coincide exactly with yours, take those which approximate most closely to them.) Then if the Difference of Latitude is to the left of Departure, you have your Course at the top of the page and your Distance in the Distance column, alongside of and to the left of your Difference of Latitude and Departure. But if the Difference of Latitude is to the right of Departure, you have your Course at the bottom of the page, and your Distance in the Distance column alongside, and to the left of Departure and Difference of Latitude.

You have now a *True* Course and Distance made good during the twenty-four hours, and with that and the position of the object on shore from which you took your departure, you will presently find your position. But we must stop for a moment to see how Courses are corrected, and Leeways and currents allowed for.

A blank Day's Work form as given you in the examination room will be of the following nature:—



THIS PAGE IS LOCKED TO FREE MEMBERS

Purchase full membership to immediately unlock this page

SAVE \$3,999,994

Did you know we sell
paperback books too?

To buy our entire catalog
in paperback would cost
over \$4,000,000

Access it all now for
\$8.99/month

*Fair usage policy applies

Continue

Departure. You will also be told that a current set the ship in such and such a direction Correct Magnetic, so many miles during the twenty-four hours, or some lesser period.

‘Departure’ in the ‘remarks’ column has nothing to do with Easting and Westing, but is used simply in its natural sense as indicating the point of land you leave or depart from.

If the bearing of the point is given you ‘by Compass,’ you must correct it for Variation and Deviation, as has been explained on page 63, then reverse it, and enter it and the Distance it is from you in the Traverse form as a Course and Distance. Don’t forget to reverse the bearing; obviously, if a point bears NW of you, and is distant ten miles, it is the same thing as if you sailed ten miles SE from it.

Next proceed to Correct the Compass Courses for Leeway, Deviation, and Variation, and enter them as True Courses in the Traverse form. Add together the knots and tenths sailed on each Course, and enter the sum alongside the Course in the Traverse form. Correct the direction of the current for Variation alone, if it is given you Correct Magnetic—if it be given True it will not need correction—and enter it in the Traverse form as a Course, and enter the number of miles the ship was set by it as a Distance. Then proceed, by the method already explained, to find the one Course and Distance resulting from all these Courses and Distances made good in the twenty-four hours.

The final process is to find your position—that is, your Latitude and Longitude In.

Write down the Latitude of the point from which you took your departure, and call it Latitude Left. Under it write your Difference of Latitude, and by comparison of

the two find your Latitude In. If your Latitude Left is North and the Difference of Latitude is North, the sum will be your Latitude In. If the Latitude Left is North, and the Difference of Latitude is South, the difference will be the Latitude In, because you are not so far North as you were before, unless your Difference of Latitude causes you to cross the Equator. But if your Difference of Latitude causes you to cross the Equator from North into South Latitude, take the Latitude Left from the Difference of Latitude, and change the name of the Latitude. Thus, if you were in 2° North Latitude, and sailed 3° South, the Latitude In would be 1° South.

All these rules hold equally good, of course, in reference to South Latitude. If Latitude Left is South, and Difference of Latitude is South, the sum will be the Latitude In; but if the Difference of Latitude is North, the difference will be the Latitude In. If your Difference of Latitude puts you across the Equator, take Latitude Left from the Difference of Latitude, and change the sign; thus: if you were in 1° South, and sailed $1^{\circ} 30'$ North, your Latitude In would be $0^{\circ} 30'$ North.

So much for fixing your Latitude. Now to find your Difference of Longitude.

Add the Latitude Left to the Latitude In, and if they are both on the same side of the Equator, the sum divided by 2 will give you the Middle Latitude. If they are on different sides of the Equator, their difference divided by 2 will give you the Middle Latitude with the name of the greater Latitude.

With the Middle Latitude as a Course in the Traverse Table, look for your Departure in the *Difference of Latitude* column, and the Distance belonging to it in

the Distance column will be the Difference of Longitude in minutes. Turn it, if it is over sixty, into degrees and minutes, and apply it to your Longitude Left. The result will be the Longitude In.

You have now got your Course and Distance made good, and your Latitude and Longitude In, and that is the whole of the problem in a Day's Work.

Though in most cases it is exceedingly easy to find the Longitude In by applying the Difference of Longitude to the Longitude Left, yet if the Difference of Longitude carries you over 180° or 0° , the process may require a little thought.

In ordinary cases if you are in East Longitude and the Difference of Longitude is East, the sum will be the Longitude In, East; and if the Difference of Longitude were West, the difference would be the Longitude In, East. For instance if you were in, say, 50° East, and made 3° Difference of Longitude East, your Longitude In would be 53° East; and if you made $2^\circ 40'$ Difference of Longitude West, you would be in $47^\circ 20'$ East. In the same way if you were in West Longitude you would find your Longitude In by adding the Difference of Longitude West to the Longitude Left, or subtracting the Difference of Longitude East.

But supposing your Longitude Left was 176° East and your Difference of Longitude were 6° East, where would you be? $176^\circ + 6^\circ$ would put you in 182° East, but there is no such thing. Take 182° from 360° , and change the sign; the result is 178° West Longitude, which is your Longitude In.

Again, supposing you were in 2° West, and made $5^\circ 30'$ Difference of Longitude East; you would have crossed the Meridian of Greenwich, and would have got into East Longitude. Take the Longitude Left from the Difference



THIS PAGE IS LOCKED TO FREE MEMBERS

Purchase full membership to immediately unlock this page

DELVE INTO FANTASY, MAGIC, MYTHOLOGY & FOLKLORE

Forgotten Books'
Full Membership gives
access to 797,885 ancient
and modern, fiction and
non-fiction books.

Continue

*Fair usage policy applies

fledged arrows will be making Easting, though in the upper half of the circles he will be making from right to left ; and that if he is sailing in the direction of the unfledged arrows he will be making Westing all round the circle. If a ship sails from A to B she will make Easting. She will do this also if she sails from D to C. And of course if she sails in the reverse direction—that is, from B to A, or from C to D—she will make Westing.

Now the Longitude of A is 7° West, and a ship sails from A to the Eastward, making 13° of Difference of Longitude. She sails 7° to the Eastward to the Meridian of Greenwich, and then 6° more, so she must be in 6° East Longitude. If she sailed from B to A, when she had made 6° Difference of Longitude she would have arrived at the Greenwich meridian, and she would then have made 7° Difference of Longitude more, which would evidently put her in 7° West Longitude.

Now suppose a ship sails from D in Longitude 173° East to C in Longitude 172° West. She will have made 7° Difference of Longitude to the Eastward to the Meridian of 180° , and then 8° more Difference of Longitude to C, altogether 15° Difference of Longitude. And although she goes from right to left in the diagram, she sails East and goes from East into West Longitude.

If she sails from C to D she will make 15° Difference of Longitude to the Westward, and will sail from West into East Longitude.

The practical rules when you want to find the Difference of Longitude between two places are :

(1) If the Longitudes of the two places are of the same name, their Difference is the Difference of Longitude named East or West as the case requires.

(2) If the Longitudes of the two places are of different names, their sum is the Difference of Longitude required,

named East if you go from West into East Longitude, and *vice versa*, except when the sum of the Longitudes of two places, one being in East and the other in West Longitude, or *vice versa*, exceed 180° , in which case it must be subtracted from 360° , and the result is the Difference of Longitude with the name of the Longitude Left.

FIG. 6.

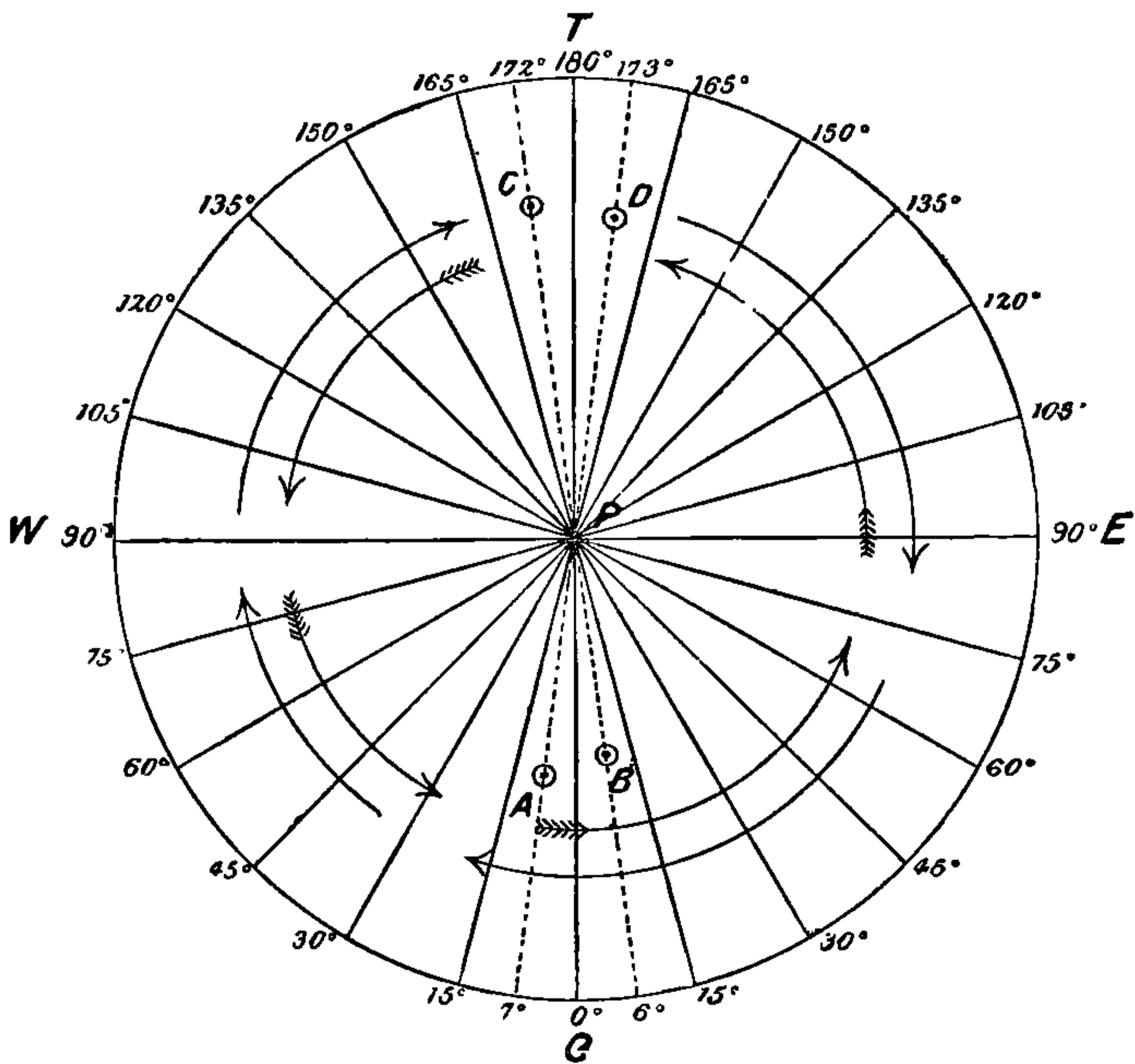

Thus, to find the Difference of Longitude between A in 160° East and B in 150° West, $160^\circ + 150^\circ = 310^\circ$ West, and $360^\circ - 310^\circ = 50^\circ$ Difference of Longitude East from A to B.

A Day's Work is really a simple affair, yet it is said that more men are sent back over a Day's Work than over any other problem in the Board of Trade Examination.

It requires to be worked with great accuracy, or large errors will arise, and to ensure accuracy it must be worked slowly, carefully, and methodically. I would recommend the learner to begin by writing down everything, and making every correction separately.

On the left-hand margin of the Examination Paper write down the Compass Course turned into degrees, minutes, and seconds. Under it write the Leeway turned into degrees, minutes, and seconds, and make that correction. Thus, suppose the Course by Compass to be NNW, Leeway $\frac{1}{4}$ point, Wind W by N.

NNW is North 2 points West, and 2 points is $22^{\circ} 30'$. $\frac{1}{4}$ point is $2^{\circ} 48' 45''$. The wind being W by N, Leeway will be towards the North, and the Compass Course corrected for it will be *less* Westerly than it was before.

Course N	$22^{\circ} 30' 0''$	W
Leeway	$2^{\circ} 48' 45''$	

N $19^{\circ} 41' 15''$ W is the Compass Course corrected for Leeway.

Suppose the Deviation to be 12° Easterly. Look from the centre of the Compass Card out towards N $19^{\circ} 41' 15''$ W, that is, towards NNW; and as Deviation is Easterly, and Correct Magnetic Course is consequently to the right of Compass Course, you will see that Deviation must be applied towards the North, and the Compass Course will become less Westerly than it was before.

Compass Course corrected		
for Leeway	.	N $19^{\circ} 41' 15''$ W
Deviation	.	$12^{\circ} 0' 0''$ E

N $7^{\circ} 41' 15''$ W is the Correct Magnetic Course.

Suppose Variation to be $23^{\circ} 25' 0''$ Westerly. Look out from the centre of the Compass Card towards N $7^{\circ} 41' 15''$ W, that is, towards N by W; and as Variation is Westerly, and the True Course is consequently to the left of Correct Magnetic, you will see that the Variation



THIS PAGE IS LOCKED TO FREE MEMBERS

Purchase full membership to immediately unlock this page

SAVE \$3,999,994

Did you know we sell
paperback books too?

To buy our entire catalog
in paperback would cost
over \$4,000,000

Access it all now for
\$8.99/month

*Fair usage policy applies

Continue

Easterly, the error is $11^{\circ} 25' 0''$ Westerly, and you would write down the whole thing thus :

Compass Course corrected for Leeway	.	N $19^{\circ} 41' 15''$ W
Compass Error	.	<u>$11^{\circ} 25' 0''$ W</u>
True Course	.	N $31^{\circ} 6' 15''$ W

If it should ever happen that you get beyond the limits of the Traverse Table, all you have to do is to halve the elements you are dealing with, and double the results.

You may be given a sailing ship's Day's Work, with a lot of Courses and Leeways and comparatively short Distances. Or you may be given a steamship's Day's Work, with few Courses, no Leeways, and Long Distances.

Here are some examples of a 'Day's Work' :

I.—DAY'S WORK

H	K	T	Course by Standard Compass	Wind	Leeway	Deviation	Remarks
1	2	8	NW $\frac{1}{2}$ N	N $\frac{1}{2}$ E	Points $\frac{1}{4}$	10° E	P.M.—A point of land in $0^{\circ} 39' N$ and $178^{\circ} 48' W$, bore by Compass ENE Distant 20 miles, Deviation as per log. Ship's Head NW $\frac{1}{2}$ N Variation 22° E
2	3	2					
3	4	4					
4	4	6					
5	5	2	SW b W	S b W	$\frac{1}{2}$	2° W	
6	5	8					
7	6	—					
8	7	—					
9	7	5	W $\frac{1}{2}$ S	NW	$\frac{1}{2}$	3° E	
10	6	5					
11	6	5					
12	5	5	"	"	"	"	
1	6	—	WSW	WNW	$\frac{3}{4}$	Nil	A.M. A current set the ship SW 'Cor. Mag.' 26 mls. during the 24 hours
2	6	5					
3	7	—					
4	7	5					
5	7	—	SSW	WSW	$1\frac{1}{4}$	8° E	
6	6	5					
7	5	5					
8	5	—					
9	5	5	S $\frac{1}{2}$ E	SW	$\frac{3}{4}$	14° E	
10	6	—					
11	6	4					
12	7	1	"	"	"	"	

<i>Sixth Course</i>			
S ½ E . . .	= S	5½° E	
Leeway	8½° W	
		S 14° E	
Deviation	14° E	
		South	
Variation	22° E	
True Course	S 22° W	
 <i>Current Course</i>			
SW . . .	= S	45°	
Variation	22° W	
		E	
True Course	S 67° W	

is found in the Dist. column = 146.5' = 2° 26' 30"

Long. left	178° 48' 0" W
Diff. Long.	2° 26' 30" W
	181° 14' 30" W
	- 360° 0' 0"
	Long. in 178° 45' 30" E

Answer.—The result of the above 24 hours' run is :

Course S 76½° W.
Dist. 151 miles.
Lat. in 0° 3½' N.
Long. in 178° 45½' E.

II.—DAY'S WORK

	K	T	Courses by Standard Compass	Wind	Leeway	Deviation	Remarks
1	19	5	WNW	West	Nil	13° W	Lizard Lt. Houses bore by Compass NNW distant 8 miles. Deviation 13° W. Variation from NOON to 6 P.M., 19° W
2	19	8					
3	20	—					
4	20	7					
5	21	—					
6	21	—					
7	20	5	NW b W	"	"	11° W	Variation from 6 P.M. till Midnight 20° W
8	20	5					
9	20	—					
10	19	5					
11	20	—	"	"	"	"	Midnight
12	20	5					
1	20	5	NW b W ½ W	NW	Nil	12° W	A.M. Variation from Midnight till 6 A.M. 21° W
2	20	5					
3	21	—					
4	21	—					
5	21	—					
6	21	—					
7	20	5	W b N ½ N	"	"	14° W	Variation from 6 A.M. till NOON 21½° W A current set the ship during the last 6 hours at the rate of 2½ knots per hour NE 'Correct Magnetic'
8	20	—					
9	20	—					
10	20	5					
11	21	—					
12	21	—					



THIS PAGE IS LOCKED TO FREE MEMBERS

Purchase full membership to immediately unlock this page

DELVE INTO FANTASY, MAGIC, MYTHOLOGY & FOLKLORE

Forgotten Books'
Full Membership gives
access to 797,885 ancient
and modern, fiction and
non-fiction books.

Continue

*Fair usage policy applies

The *Answer* is :

Course S 83° W.

Dist. 472 miles.

Lat. in 49° 30' 19" N.

Long. in 17° 15' 43" W.

The problem of a 'Day's Work' is included in the examination for Second Mate.

CHAPTER VI

ALGEBRA AND TRIGONOMETRY

I do not advise anyone to read this chapter unless he is working for an Extra Master's Certificate, or wants to understand the theory upon which the solutions of the various problems in the 'Sailings' are based. The beginner should content himself with learning the formulas and working the problems as explained in the preceding pages. After he has become familiar with the practical work, he may with profit peruse this chapter.

As in all the Sailings except Great Circle Sailing, the earth's surface is treated as if it were flat, the various problems consist of the solution of right-angled plane triangles, and a few words on Plane Trigonometry, and on Algebra, may be advisable. Those who understand Trigonometry had better not read them, and those who do not understand Trigonometry need not read them unless they want to know the 'reason why' for the various formulas adopted in the Sailings, or unless they want to take an Extra Master's Certificate. Some knowledge of Trigonometry is necessary for that purpose, as the aspirant will be required to draw and solve plane triangles. The more he knows of Trigonometry the better; but if he has not time nor inclination to study it,

I think what I propose to say will be quite sufficient for all purposes.

But before starting on Trigonometry, a word or two on the Algebraical forms used are necessary.

An equation in Algebra means that two quantities, one on each side of the symbol =, are equal, though expressed in different terms. Thus 6 multiplied by 2 equals 12 ; and 36 divided by 3 equals 12 ; therefore 6 multiplied by 2, and 36 divided by 3, are the same thing, and can be written as an Algebraical equation, thus :

$$6 \times 2 = \frac{36}{3}$$

The advantage attaching to an equation is that you can do any mortal thing to one side of it, providing you do the same thing to the other side, and the equation will still hold ; thus you might multiply 6×2 by any number, or you might divide it by any number, or add to or take from it any number you like, and the equation would remain true, providing that you did exactly the same thing to the other side, which is $36 \div 3$. This is self-evident as regards figures, but it is not so clear when letters are used. Thus it is evident that 6 multiplied by 2 equals 12, and $6 \times 2 \times 2$ equals 24, and that 36 divided by 3 equals 12, and that 12 multiplied by 2 equals 24, and that, therefore, the proportion between them remains unaltered.

Letters are generally used in Algebra as expressing some known or unknown quantity, known quantities usually being represented by the first letters of the alphabet, and unknown quantities by the last. The unknown quantity is always placed, if possible, on the left of the equation.

To show the advantage of using equations, and how to do so practically : Let 2 be represented by a ; 3 by b ;



THIS PAGE IS LOCKED TO FREE MEMBERS

Purchase full membership to immediately unlock this page

SAVE \$3,999,994

Did you know we sell
paperback books too?

To buy our entire catalog
in paperback would cost
over \$4,000,000

Access it all now for
\$8.99/month

*Fair usage policy applies

Continue

from minus to plus, or from multiplication to division, or from division to multiplication.

Now supposing the equation stands thus: x equals a multiplied by b , multiplied by c ; in equational form,

$$x = a \times b \times c$$

or in figures $x = 2 \times 3 \times 4$

Therefore $x = 24$

This is perfectly clear. But if the equation appears thus: x divided by a equals b multiplied by c , which in Algebraical form is,

$$\frac{x}{a} = b \times c$$

or in figures $\frac{x}{2} = 3 \times 4$, how is it to be solved?

x is divided by a on one side; if we multiply this by a , then x divided by a and multiplied by a becomes of course x ; but we have multiplied one side of the equation by a ; it is therefore necessary to multiply the other side by a , and the equation would stand thus: $\frac{x}{a} \times a = b \times c \times a$. But x divided by a and multiplied by a is x , and so we come to $x = b \times c \times a$. We have shifted a from one side of the equation to the other, and have changed its function from division to multiplication. To show this in figures,

$$\frac{x}{2} = 3 \times 4$$

or $\frac{x}{2} \times 2 = 3 \times 4 \times 2$

or eliminating both 2's

$$x = 3 \times 4 \times 2 = 24$$

Hence it is plain that when dealing with fractions

in Algebraical equations, the rule is, that if you transfer a numerator from one side it becomes a denominator on the other, and *vice versa*.

Take another instance of an equation.

$$\frac{x}{b \times c} = a, \text{ or in figures, } \frac{x}{3 \times 4} = 2$$

Here $b \times c$ is the denominator of the fraction $\frac{x}{b \times c}$. On the other side of the equation we have a , which we can express fractionally as $\frac{a}{1}$, because the value of any number divided by 1 remains unaltered. Well then, we have,

$$\frac{x}{b \times c} = \frac{a}{1}$$

Transfer the denominator $b \times c$ to the other side, changing its sign, thus:

$$x = \frac{a \times b \times c}{1}$$

and transfer the denominator 1 to the other side, changing its sign, thus:

$$x \times 1 = a \times b \times c$$

or as multiplying by 1 makes no difference to x ,

$$x = a \times b \times c$$

To show this in figures,

$$\frac{x}{3 \times 4} = \frac{2}{1}$$

or
$$x = \frac{2 \times 3 \times 4}{1}$$

or
$$x \times 1 = 2 \times 3 \times 4$$

and
$$x = 2 \times 3 \times 4 = 24$$

In dealing with symbols it is very convenient to bracket two or more of them together when those two or more are collectively affected by some other symbol or quantity. If you are concerned with known quantities, there is no particular object in bracketing. Suppose you want to subtract 12 added to 5 from 18; or 12 less 5 from 18; you would simply say $12 + 5 = 17$, and $18 - 17 = 1$; or $12 - 5 = 7$, and $18 - 7 = 11$. But suppose you want to subtract a added to b from c ; or a less b from c : how would you represent it? By bracketing a and b . Thus:

$$c - (a + b)$$

or

$$c - (a - b)$$

When quantities or symbols are bracketed together, they must be dealt with as a single quantity or symbol. You can do anything with a set of figures in brackets that can be done with a single figure or symbol. Figures or symbols in brackets cannot be dealt with separately, until and unless the brackets are removed.

The numerators and denominators of fractions, if they are composed of more than one term, must always be dealt with as if they were bracketed.

Another method of indicating that quantities or symbols are bracketed is by drawing a line over such quantities. Thus $(x + y)$ may be represented by $\overline{x + y}$; $(a - b)$ by $\overline{a - b}$; and $(a + b - c)$ by $\overline{a + b - c}$.

When removing brackets, it is necessary to remember the following rules:—

(a) When there is a *plus* sign before the bracket, the signs of the quantities or symbols bracketed do not change when the brackets are removed.

(b) When there is a *minus* sign before the bracket, the signs of the quantities or symbols bracketed must all be changed when the brackets are removed.



THIS PAGE IS LOCKED TO FREE MEMBERS

Purchase full membership to immediately unlock this page

DELVE INTO FANTASY, MAGIC, MYTHOLOGY & FOLKLORE

Forgotten Books'
Full Membership gives
access to 797,885 ancient
and modern, fiction and
non-fiction books.

Continue

*Fair usage policy applies

$+$ \div $-$ gives $-$; $-$ \div $+$ gives $-$. Likes give $+$ and unlikes give $-$.

You will sometimes come across a letter or number with a small 2 above it and to the right, thus— a^2 , 7^2 , 12^2 , AB^2 . These are called a squared, 7 squared, 12 squared, AB squared respectively, and denote $a \times a$, 7×7 , 12×12 , $AB \times AB$, being in fact simply a short way of writing these expressions.

The symbol $\sqrt{\quad}$ will occur sometimes. This is called the square root. Thus $3 = \sqrt{9}$: or 3 is the square root of 9. Sometimes the number under the square root is not a square number. For instance, no number is exactly equal to $\sqrt{2}$; which is, however, approximately equal to 1.4.

That is all the Algebra you need to know in order to follow the formulas used in solving right-angled plane triangles ; and by their solution all the problems in the sailings are worked.

Trigonometrical Ratios

(A knowledge of the Trigonometrical Ratios is required of the candidates for Extra Master's Certificates.)

Before proceeding further, it is necessary that you should understand a little about circles and angles. Take a pair of dividers and describe a circle. You will see that the bounding line is one curved line, and that every point in this line is the same distance from the point where the fixed leg of the dividers pricked the paper. Further, the curve all lies on one flat sheet of paper, and does not ever leave it as a curve like a corkscrew would. These facts are all embodied in the following definition of a

circle. A circle is a plane figure bounded by one curved line, and such that all points in the boundary are at the same distance from a certain point inside the figure called the centre. Any line drawn through the centre will divide the circle into equal halves or semicircles. When these are divided into halves we obtain quadrants. The bounding line of a circle is called the circumference, and any portion of it is called an arc. Any straight line

FIG. 7

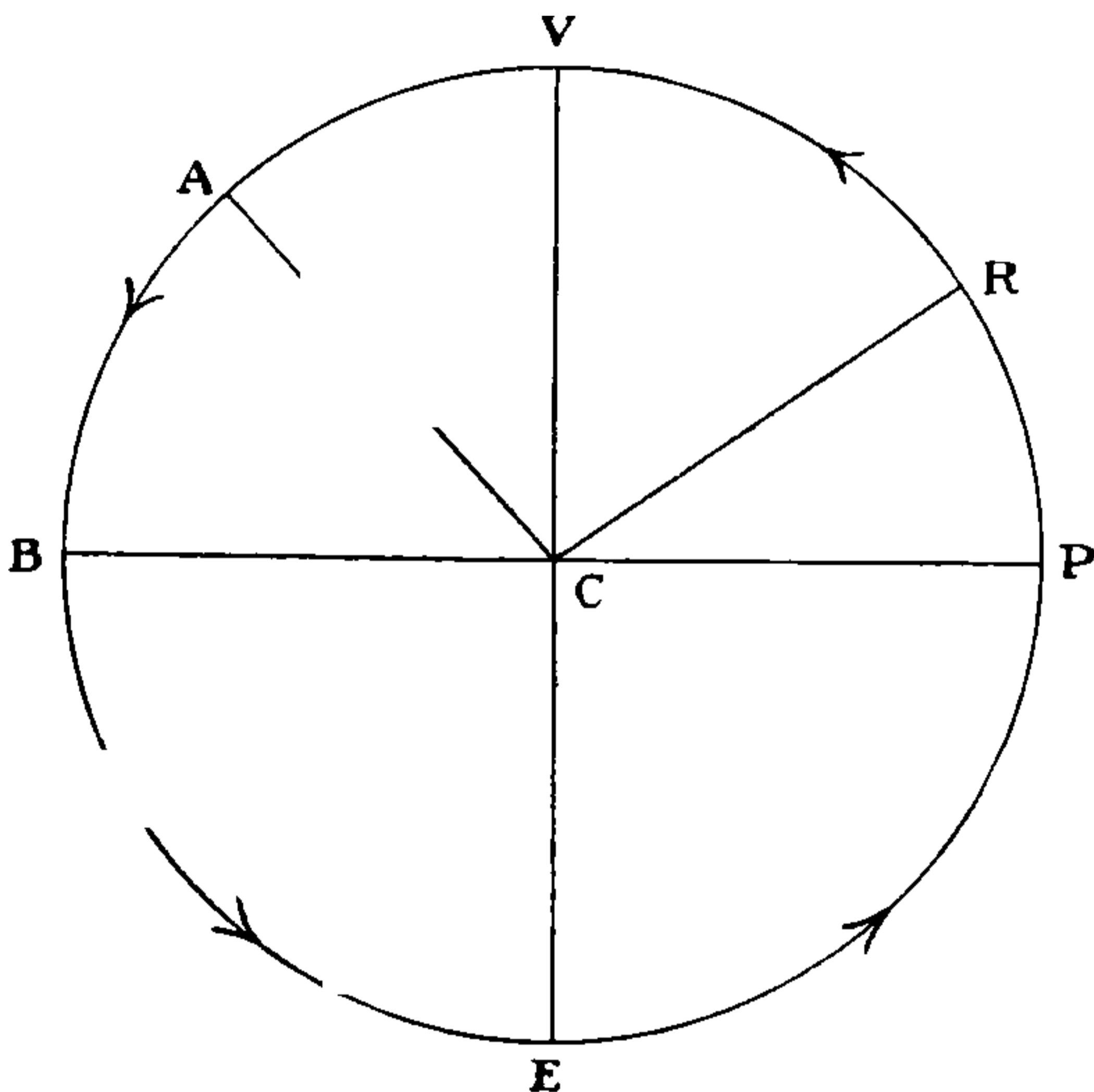

from the centre to the circumference is called a radius, and a straight line right through the centre from circumference to circumference is called a diameter. Thus in the diagram, C is the centre of the circle; each of the lines CP, CR, CV, CA, CB, CE, is a radius; BP and VE are diameters. The curved line PRVABEP is the circumference; PR, RV, VA, AB, are arcs. The lines PCB and VCE each divide the circle into semicircles; PRVC, VABC, BEC, and CEP are quadrants.

Next suppose the circle was described by the radius or arm, CP revolving in the direction indicated by the arrows. The arm goes through various positions, such as CR , CA , CB , CE , before it finally gets back again to the position CP . The amount it revolves is called an angle. Thus the amount the arm has turned from the position CP to the position CR is called the angle PCR ; the amount the arm turns in going from the position CR to

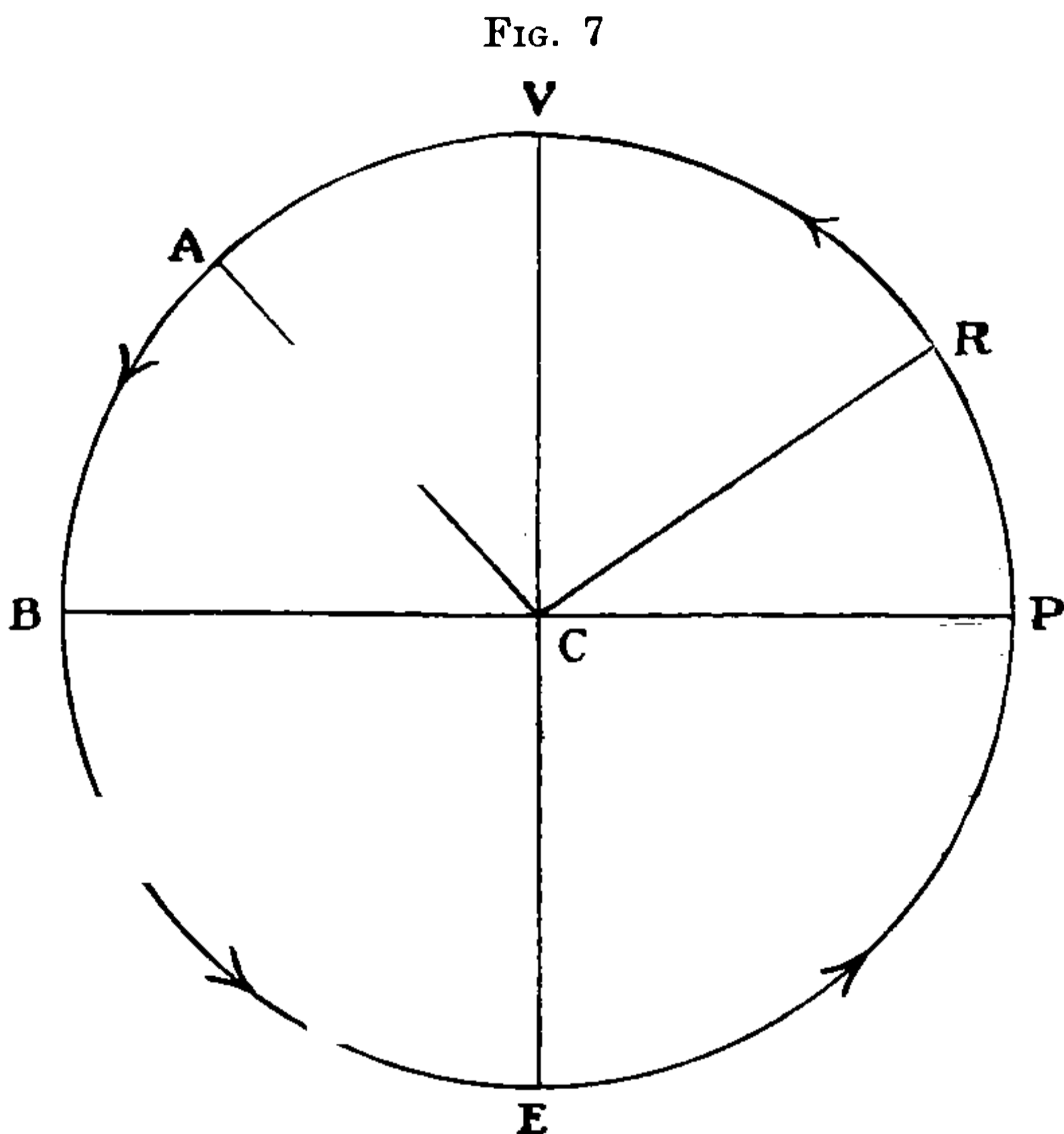

CV is the angle RCV . In revolving completely round the arm CP traces out an angle of four right angles, or of 360° ; if it goes half round, say from CP to CB , the angle described is two right angles, or 180° ; if it goes a quarter round, it traces out one right angle, or 90° . Thus in the figure PCV , VCB , BCE , ECP , and RCA are all right angles.

An angle of 360° , therefore, corresponds to the total circumference of a circle, an angle of 180° to a semicircle,



THIS PAGE IS LOCKED TO FREE MEMBERS

Purchase full membership to immediately unlock this page

SAVE \$3,999,994

Did you know we sell
paperback books too?

To buy our entire catalog
in paperback would cost
over \$4,000,000

Access it all now for
\$8.99/month

*Fair usage policy applies

Continue

Let us consider any angle PCR , which we will call the angle c . Take any point Q in the line CR , and draw QN perpendicular to CP . Then CQN is a right-angled

FIG. 9

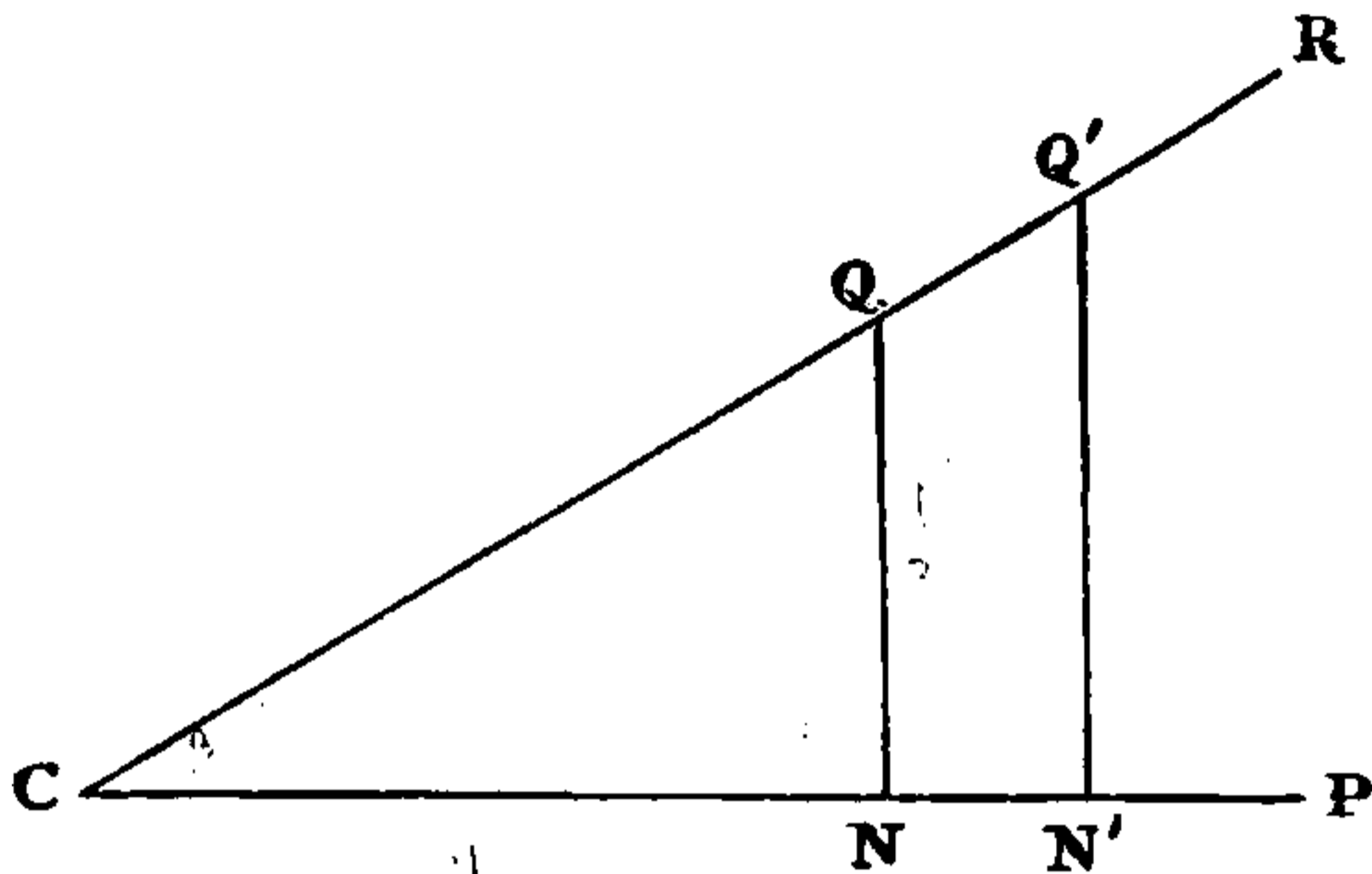

triangle, and CQ , the side opposite the right angle, is called the Hypotenuse; QN , the side opposite C , is called the Perpendicular; CN , the side through C , is called the Base.

In any right-angled triangle,

$\frac{\text{Perpendicular}}{\text{Hypotenuse}}$ is called the Sine

$\frac{\text{Base}}{\text{Hypotenuse}}$ " " " Cosine

$\frac{\text{Perpendicular}}{\text{Base}}$ " " " Tangent

$\frac{\text{Hypotenuse}}{\text{Perpendicular}}$ " " " Cosecant

$\frac{\text{Hypotenuse}}{\text{Base}}$ " " " Secant

$\frac{\text{Base}}{\text{Perpendicular}}$ " " " Cotangent

Thus

$$\frac{QN}{CQ} = \text{Sin } c$$

$$\frac{CQ}{QN} = \text{Cosec } c$$

$$\frac{CN}{CQ} = \text{Cos } c$$

$$\frac{CQ}{CN} = \text{Sec } c$$

$$\frac{QN}{CN} = \text{Tan } c$$

$$\frac{CN}{QN} = \text{Cot } c$$

These quantities are called the trigonometrical ratios of the angle c , and the important point to notice about them is that their *value does not at all depend on where in the line CR the point Q has been taken.*

If Q had been taken twice as far away from C , CN and NQ would both have been doubled. Let us take another point Q' , and draw $Q'N'$ perpendicular to CP . The two triangles QCN and $Q'CN'$ are exactly the same shape, or what Euclid calls *similar*; and the three sides of each triangle will have the same proportion to one another, no matter what difference exist in the actual size of the triangles. Suppose in one triangle the sides were 3, 4, and 5 feet respectively; the sides in the other triangle must be in the same proportion. That is, they might be 3, 4, and 5 miles in length, or 3, 4, and 5 inches, or 3×5 , 4×5 , and 5×5 feet. The ratios—that is the proportion to one another—of the sides to one another are the same so long as the angle c is the same, and do not depend on the scale on which the triangle QCN is drawn. For example, the ratio of the perpendicular to the base would be $\frac{3}{4}$, whether it were $\frac{3 \text{ miles}}{4 \text{ miles}}$ or $\frac{3 \text{ inches}}{4 \text{ inches}}$ or $\frac{15 \text{ feet}}{20 \text{ feet}}$ or $\frac{1\frac{1}{2} \text{ inches}}{2 \text{ inches}}$.

The whole value of plane trigonometry to the navigator depends on the fact that these ratios have been

tabulated for all angles, and what is more convenient, their logarithms have been tabulated. You have already used them in Table XXV. in the Sailings. The way in which they are used is shown a little further on in the chapter.

Since the sum of the three angles of a triangle is two right angles or 180° (Euclid I. 32) it follows that in a right-angled triangle where one of the angles is 90° , the sum of the other two angles is also 90°

FIG. 10

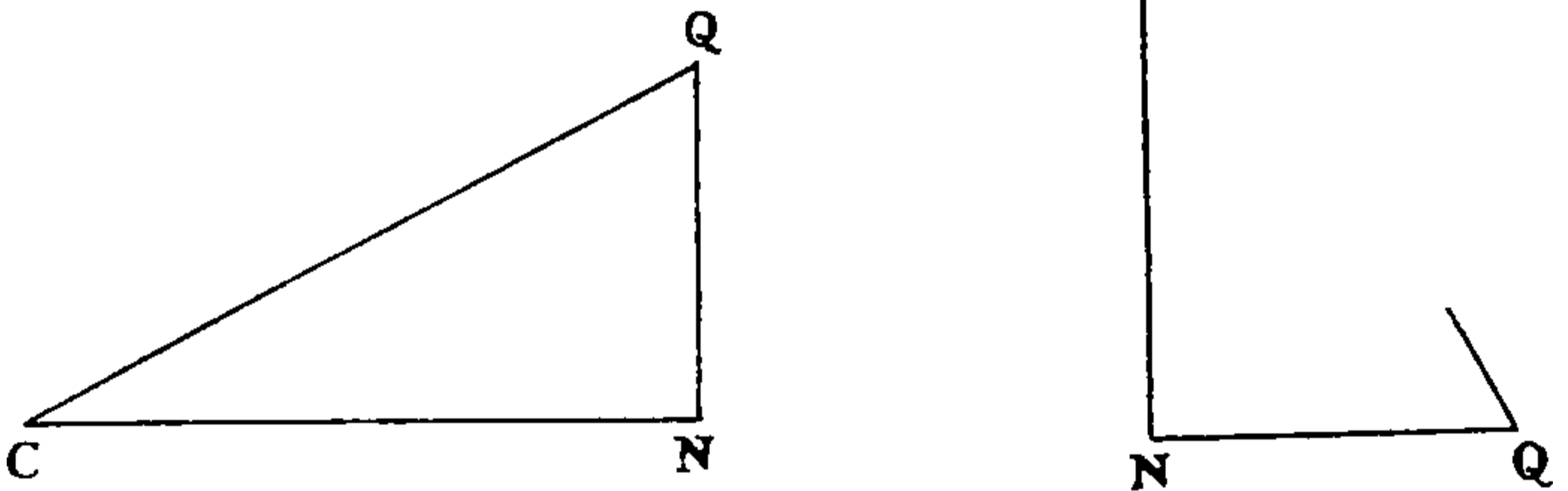

$$\text{Thus } c + q = 90^\circ$$

$$\text{or } q = 90^\circ - c$$

That is to say, q is the complement of c , and equally c is the complement of q .

Now since CN is the side opposite q , $\text{Sin } q = \frac{CN}{CQ}$.

But $\frac{CN}{CQ} = \text{Cos } c$.

Therefore $\text{Sin } q = \text{Cos } c$, that is to say, the sine of an angle is the cosine of its complement. Similarly, the tangent of an angle is the cotangent of its complement, and the secant of an angle is the cosecant of its complement.

These results will be useful later, but the main point to grasp is that in the trigonometrical tables the ratios



THIS PAGE IS LOCKED TO FREE MEMBERS

Purchase full membership to immediately unlock this page

DELVE INTO FANTASY, MAGIC, MYTHOLOGY & FOLKLORE

Forgotten Books'
Full Membership gives
access to 797,885 ancient
and modern, fiction and
non-fiction books.

Continue

*Fair usage policy applies

applies to the angles AOR and AOS . In fact all these angles have the same Trigonometrical Ratios, if no account is taken of the sign.

In order to distinguish the quadrants, the following rule of signs is made. OP the radius is always counted $+$. When a point is to the right of $BO D$, its distance

FIG. 11

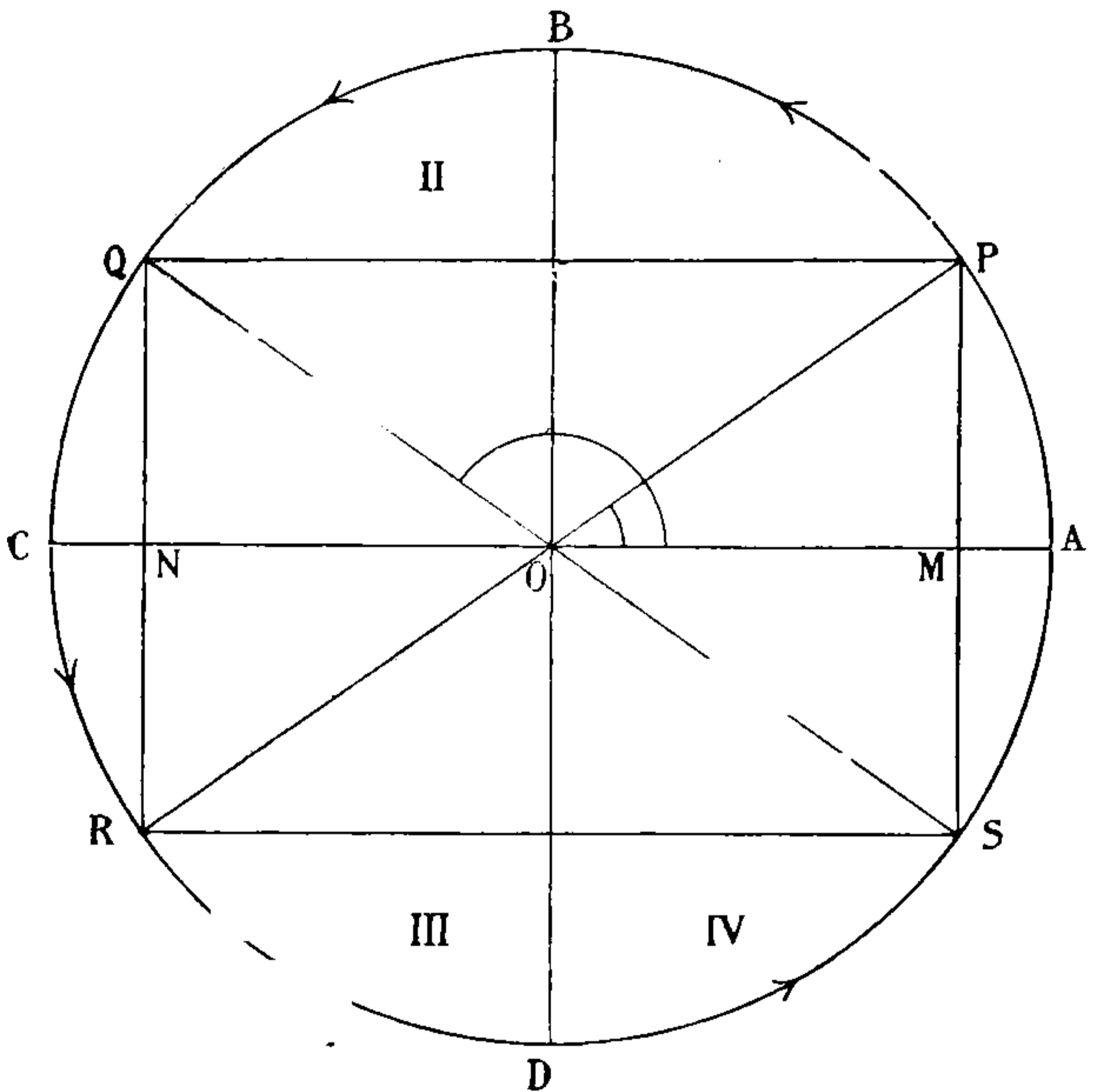

from $BO D$ is counted $+$, but when to the left it is counted $-$. Similarly when a point is above $AO C$, its distance from $AO C$ is counted $+$, and when below $AO C$ it is counted $-$. Thus in the diagram the signs are as follows:

1st Quadrant	$OP +$	$OM +$	$PM +$
2nd Quadrant	$OQ +$	$ON -$	$QN +$
3rd Quadrant	$OR +$	$ON -$	$RN -$
4th Quadrant	$OS +$	$OM +$	$SM -$

In the 1st Quadrant, since the Trigonometrical Ratios are $\frac{+}{+}$, they are all $+$.

In the 2nd Quadrant, the Sine is $\frac{+ \text{ Q N}}{+ \text{ O Q}} = +$.

The Cosine is $\frac{- \text{ O N}}{+ \text{ O Q}} = -$.

The Tangent is $\frac{+ \text{ Q N}}{- \text{ O N}} = -$.

The Cosecant is $\frac{+ \text{ O Q}}{+ \text{ Q N}} = +$.

The Secant is $\frac{+ \text{ O Q}}{- \text{ O N}} = -$.

The Cotangent is $\frac{- \text{ O N}}{+ \text{ Q N}} = -$.

You can examine the signs in the 3rd and 4th Quadrants for yourself. You will find the following:

	Sine	Cosine	Tangent	Cosecant	Secant	Cotangent
1st Quadrant	+	+	+	+	+	+
2nd Quadrant	+	-	-	+	-	-
3rd Quadrant	-	-	+	-	-	+
4th Quadrant	-	+	-	-	+	-

In most cases you will know that the angle you want is between 0° and 180° , so that you will only need to consider the 1st and 2nd Quadrants. Suppose you know that the Cosine of an angle is $-$; the angle you find in the tables will not be the angle you want, but all you will need to do is to find the corresponding angle in the 2nd Quadrant, and to get this you must deduct the angle you have taken out from 180° .

For instance: Suppose you want an angle whose Cosine was $-$ and whose Log. Cos = 9.918574. Reference to the Tables gives 34° as the angle corresponding to Log. Cos 9.918574. But Cosine 34° is $+$ and 34° cannot therefore be the angle required, but $180^\circ - 34^\circ = 146^\circ$,

and $\text{Cos } 146^\circ$ is $-$ and is numerically the same as $\text{Cos } 34^\circ$. Therefore, evidently, 146° is the angle you want. Take the converse case. What is the Log. Cos of 150° ? 150° is not in the Tables, but $180^\circ - 150^\circ$ or 30° is in the Tables; and $\text{Log. Cos } 150^\circ = \text{Log. Cos } 30^\circ = 9.937531$, but do not forget that $\text{Cos. } 150^\circ$ is $-$.

You may be interested to know how the Trigonometrical Ratios got their names of Sine, Cosine, Tangent, etc. These names were not given in the first instance to the Ratios, but the old Mathematicians who invented

FIG. 12

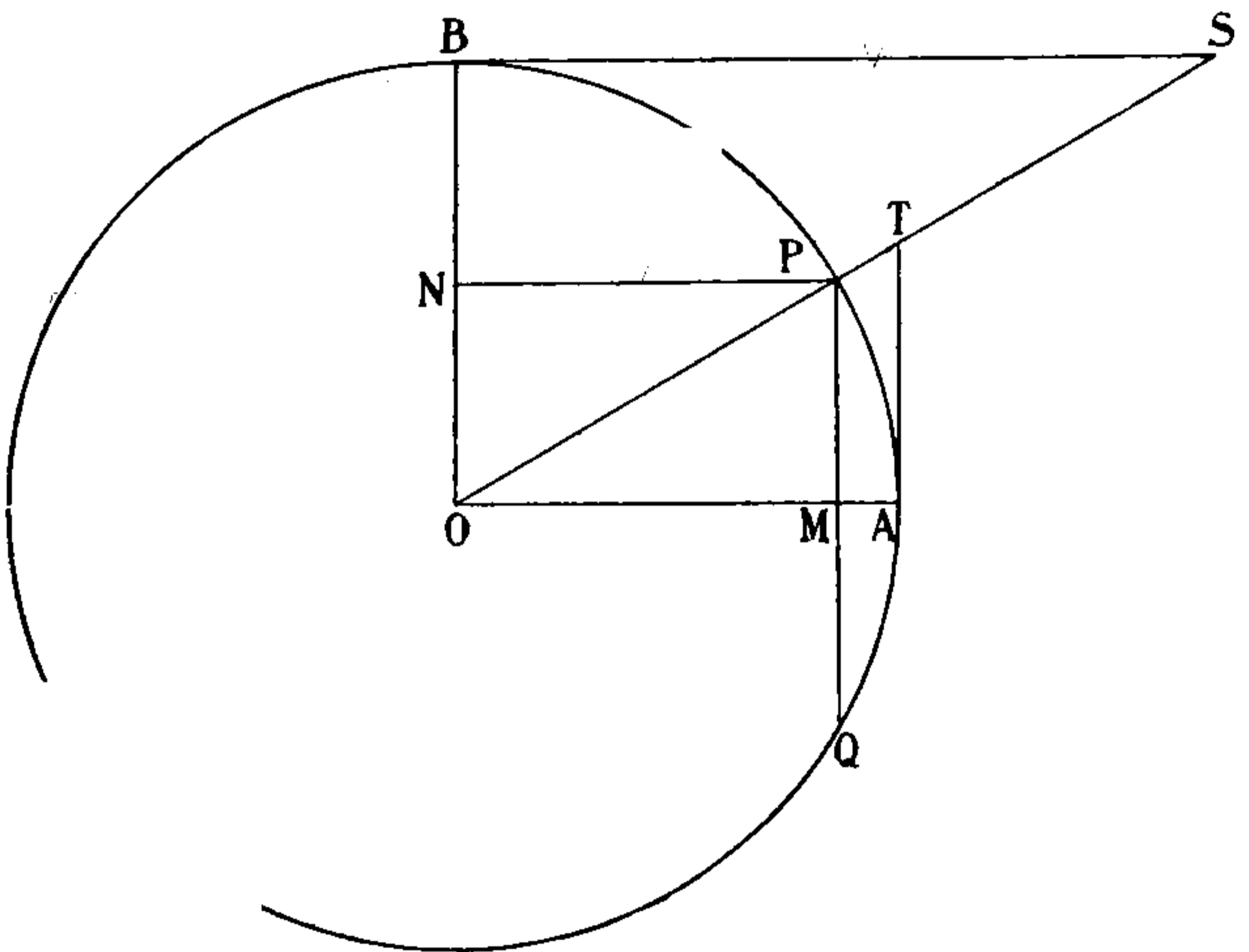

Trigonometry drew a figure like the above. They called AP the **Arc**, because it is like a bow; AT the **Tangent**, because it touches the circle at A ; and TO the **Secant**, because it cuts the circle at P ; and PM the **Sine**, because, corresponding to the string of the bow, it touches the breast (*sinus*) of the Archer. The angle POB is the complement of POA , and the corresponding lines belonging to this angle they called by the same names with **Co-** put before them. Thus PN is the **Cosine**,



THIS PAGE IS LOCKED TO FREE MEMBERS

Purchase full membership to immediately unlock this page

SAVE \$3,999,994

Did you know we sell
paperback books too?

To buy our entire catalog
in paperback would cost
over \$4,000,000

Access it all now for
\$8.99/month

*Fair usage policy applies

Continue

join $A D$. In the two triangles $A B D$ and $A C D$, the side $A B$ equals the side $A C$; the side $B D$ equals the side $D C$; and the side $A D$ is common to both triangles, they are therefore equal in every respect (Euclid I. 8). The angle $B A D$ is equal to the angle $C A D$, and as the angle $B A C$ equals 60° , the angles $B A D$ and $C A D$ are each equal to 30° . Now the Sine of $B A D = \frac{B D}{A B}$, but $B D$ is one half

FIG. 13

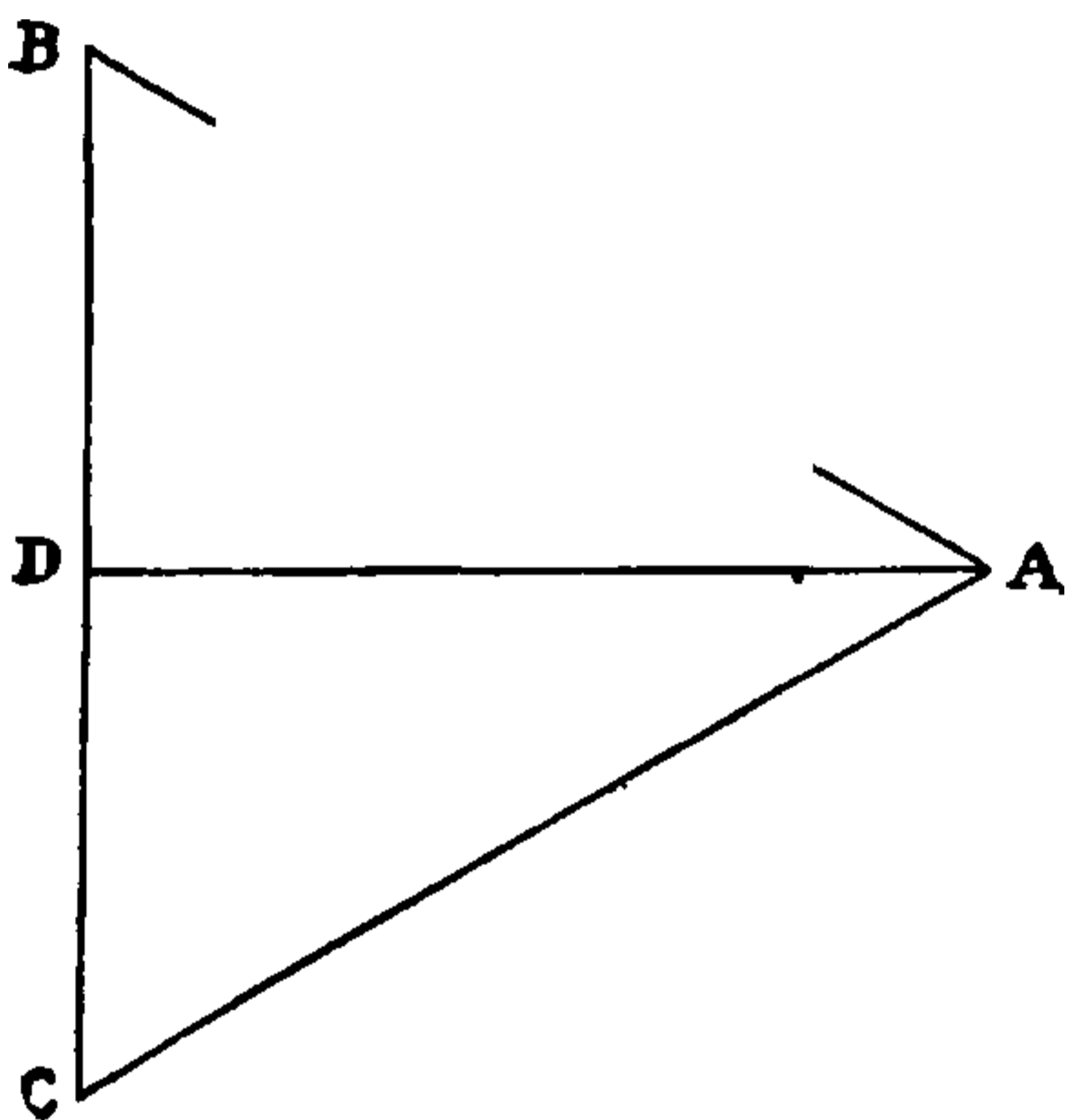

of $B C$ by construction, it is therefore also the half of $B A$, since $B A$ and $B C$ are equal: let $B D$ be equal to 1 , then $A B$ must be equal to 2 . Now we have

$$\text{Sine } B A D = \frac{B D}{A B} = \frac{B D}{2 B D} = \frac{1}{2}$$

That is $\text{Sine } 30^\circ = \frac{1}{2}$.

In any right-angled triangle the square of the side opposite to the right angle is equal to the sum of the squares of the other two sides (Euclid I. 47).

$$\text{Therefore } A B^2 = A D^2 + B D^2.$$

$AB = 2BD$, therefore $AB^2 = 4BD^2$, and substituting this value of AB^2 in the equation, we have

$$4BD^2 = AD^2 + BD^2$$

$$\text{therefore } AD^2 = 4BD^2 - BD^2 = 3BD^2$$

$$\text{or } AD = BD\sqrt{3}$$

$$\text{or } \frac{AD}{BD} = \frac{\sqrt{3}}{1}$$

$$\text{and } AD : BD :: \sqrt{3} : 1$$

We have already seen that

$$BD : AB :: 1 : 2$$

We have therefore the proportion between all three sides, namely :

$$AB : BD : AD :: 2 : 1 : \sqrt{3},$$

and no matter what size the right-angled plane triangle may be, the sides are in proportion to one another so long as the angle BAD is 30° .

Let us now see what the actual values of the other Trigonometrical Ratios of this angle are.

$$\text{Cos } 30^\circ \text{ or Cos } BAD = \frac{AD}{AB} = \frac{\sqrt{3}}{2} = \frac{1}{2}\sqrt{3}$$

$$\text{Tan } 30^\circ \text{ or Tan } BAD = \frac{BD}{AD} = \frac{1}{\sqrt{3}}$$

$$\text{Cot } 30^\circ \text{ or Cot } BAD = \frac{AD}{BD} = \frac{\sqrt{3}}{1} = \sqrt{3}$$

$$\text{Sec } 30^\circ \text{ or Sec } BAD = \frac{AB}{AD} = \frac{2}{\sqrt{3}}$$

$$\text{Cosec } 30^\circ \text{ or Cosec } BAD = \frac{AB}{AD} = \frac{2}{1} = 2$$

Trigonometrical Ratios of 60° .—You know that 60° is the complement of 30° , and therefore that $\text{Sin } 60^\circ = \text{Cos}$

30° , and so on. All you have to do then is to write them down from the ratios of 30° already given, thus :

$$\begin{aligned} \sin 60^\circ &= \cos 30^\circ &= \frac{1}{2} \sqrt{3} \\ \cos 60^\circ &= \sin 30^\circ &= \frac{1}{2} \\ \tan 60^\circ &= \cot 30^\circ &= \sqrt{3} \\ \cot 60^\circ &= \tan 30^\circ &= \frac{1}{\sqrt{3}} \\ \sec 60^\circ &= \operatorname{cosec} 30^\circ &= 2 \\ \operatorname{cosec} 60^\circ &= \sec 30^\circ &= \frac{2}{\sqrt{3}} \end{aligned}$$

Trigonometrical Ratios of 45° .—In the triangle $A B C$ let $A = 45^\circ$ and $C = 90^\circ$.

FIG. 14

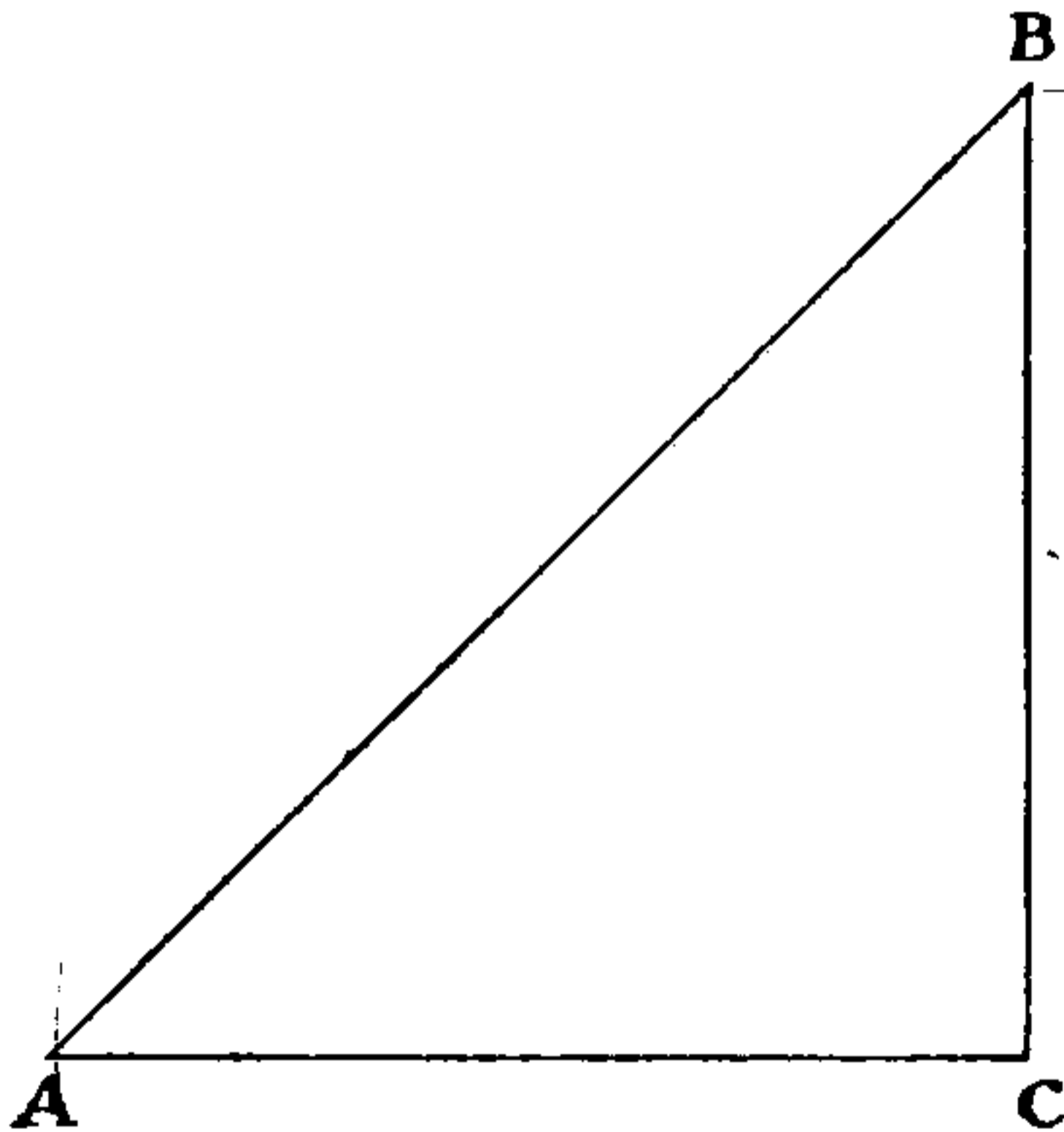

By Euclid because the angles A and B are equal, each being 45° , the sides $A C$ and $B C$ are equal. Let us suppose them to be each equal to 1. Because C is a right angle

$$\begin{aligned} A B^2 &= A C^2 + B C^2 \\ &= 1^2 + 1^2 \\ &= 1 + 1 \\ &= 2 \end{aligned}$$

and

$$A B = \sqrt{2}$$



THIS PAGE IS LOCKED TO FREE MEMBERS

Purchase full membership to immediately unlock this page

DELVE INTO FANTASY, MAGIC, MYTHOLOGY & FOLKLORE

Forgotten Books'
Full Membership gives
access to 797,885 ancient
and modern, fiction and
non-fiction books.

Continue

*Fair usage policy applies

Look in Table XXV. and you will find that this is right.

$$\begin{aligned} \text{Tan } 30^\circ &= \frac{1}{\sqrt{3}} \\ \text{Log. Tan } 30^\circ &= \text{Log. } 1 - \frac{1}{2} \text{Log. } 3 \\ &\begin{array}{r} 1 \text{ Log. } 0\cdot000000 \\ \sqrt{3} \text{ Log. } 0\cdot238560 \\ \hline 30^\circ \text{ Log. Tan } 9\cdot761440 \end{array} \end{aligned}$$

$$\begin{aligned} \text{Sec } 30^\circ &= \frac{2}{\sqrt{3}} \\ \text{Log. Sec } 30^\circ &= \text{Log. } 2 - \frac{1}{2} \text{Log. } 3 \\ &\begin{array}{r} 2 \text{ Log. } 0\cdot301030 \\ \sqrt{3} \text{ Log. } 0\cdot238560 \\ \hline 30^\circ \text{ Log. Sec } 10\cdot062470 \end{array} \end{aligned}$$

$$\begin{array}{r} 3 \text{ Log. } 2) 0\cdot477121 \\ \hline \sqrt{3} \text{ Log. } 0\cdot238560 \end{array}$$

You will notice that in Table XXV. 10 is always borrowed to add to the Index of the Logs. of ratios of angles to avoid minus quantities.

$$\begin{aligned} \text{Cos } 45^\circ &= \frac{1}{\sqrt{2}} \\ \text{Log. Cos } 45^\circ &= \text{Log. } 1 - \frac{1}{2} \text{Log. } 2 \\ &\begin{array}{r} 1 \text{ Log. } 0\cdot000000 \\ \sqrt{2} \text{ Log. } 0\cdot150515 \\ \hline 45^\circ \text{ Log. Cos } 9\cdot849485 \end{array} \end{aligned}$$

$$\begin{array}{r} 2 \text{ Log. } \cdot301030 \\ \sqrt{2} \text{ Log. } \cdot150515 \end{array}$$

The advantage to be derived by the use of these ratios is that they establish for us certain proportions between

Fig. 14

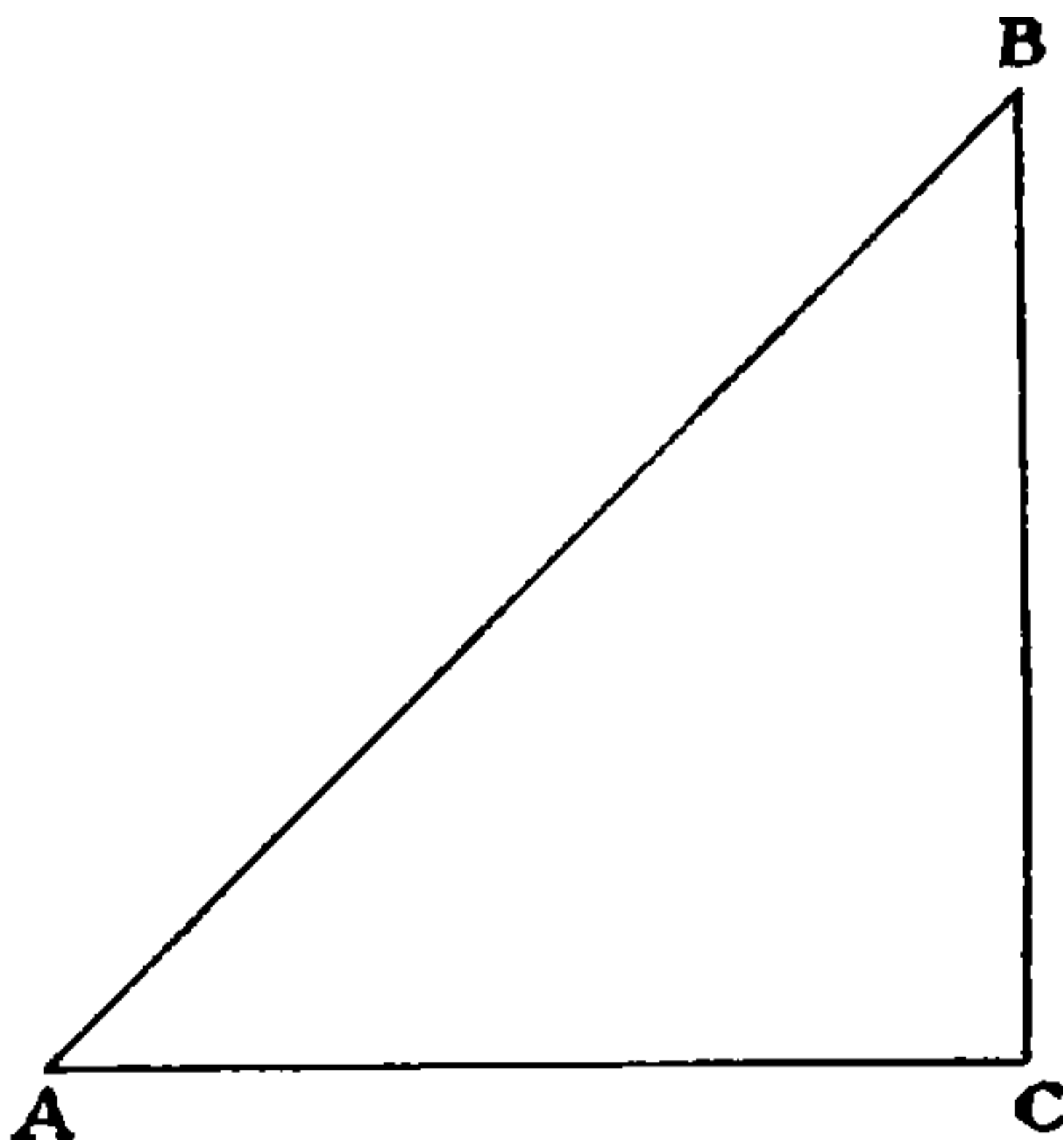

the sides. For example, in the right-angled plane triangle A B C let the angle A be 45° and the side B C 1,780 yards ; to

find AB . You know that the Trigonometrical Ratio of the Cosecant of 45° is $\frac{\sqrt{2}}{1}$, and that the sides AB and BC are in the same proportion. Thus :

$$\frac{\sqrt{2}}{1} = \frac{AB}{BC}$$

or $\sqrt{2} : 1 :: AB : BC$

therefore $\sqrt{2} : 1 :: AB : 1780$

therefore $AB = 1780 \times \sqrt{2}$

But the Cosecant of $45^\circ = \sqrt{2}$, and instead of all the trouble and bother of dealing with such a quantity as the $\sqrt{2}$, I simply take out the Log. Cosecant of 45° and add to it the Log. of 1780, which gives me the Log. of AB .

Now let us collect the results, omitting in every case the words Trigonometrical Ratio, which will be understood. We have then in any right-angled triangle,

$$\text{Sine} = \frac{\text{Perpendicular}}{\text{Hypotenuse}}$$

$$\text{Cosine} = \frac{\text{Base}}{\text{Hypotenuse}}$$

$$\text{Tangent} = \frac{\text{Perpendicular}}{\text{Base}}$$

$$\text{Cotangent} = \frac{\text{Base}}{\text{Perpendicular}}$$

$$\text{Secant} = \frac{\text{Hypotenuse}}{\text{Base}}$$

$$\text{Cosecant} = \frac{\text{Hypotenuse}}{\text{Perpendicular}}$$

These ratios must be committed to memory. With their help all problems in right-angled plane trigonometry can be solved; all the 'sailings' can be worked; and with the addition of a few formulas given later on for

solving plane triangles other than right-angled, all the work required to obtain an Extra Master's Certificate can be done, as far as plane surfaces are concerned.

In addition to the above ratios, there are two others which are commonly used in solving trigonometrical problems. These are the Versine and Haversine, or Half Versine.

The Versine of an angle is the difference between one and its Cosine, that is $1 - \text{Cosine}$.

The Haversine of any angle is the half of its Versine.

Solution of Right-angled Triangles

(The solution of Right-angled Plane Triangles is required in the Examination for Extra Master's Certificate.)

It is usual to denote the angles by capital letters, and the sides by the same letter in ordinary type. Thus in the triangle $A B C$, of which c is the right angle, c is the side opposite to it, A and B are the other angles, the sides opposite to which are respectively a and b .

FIG. 15

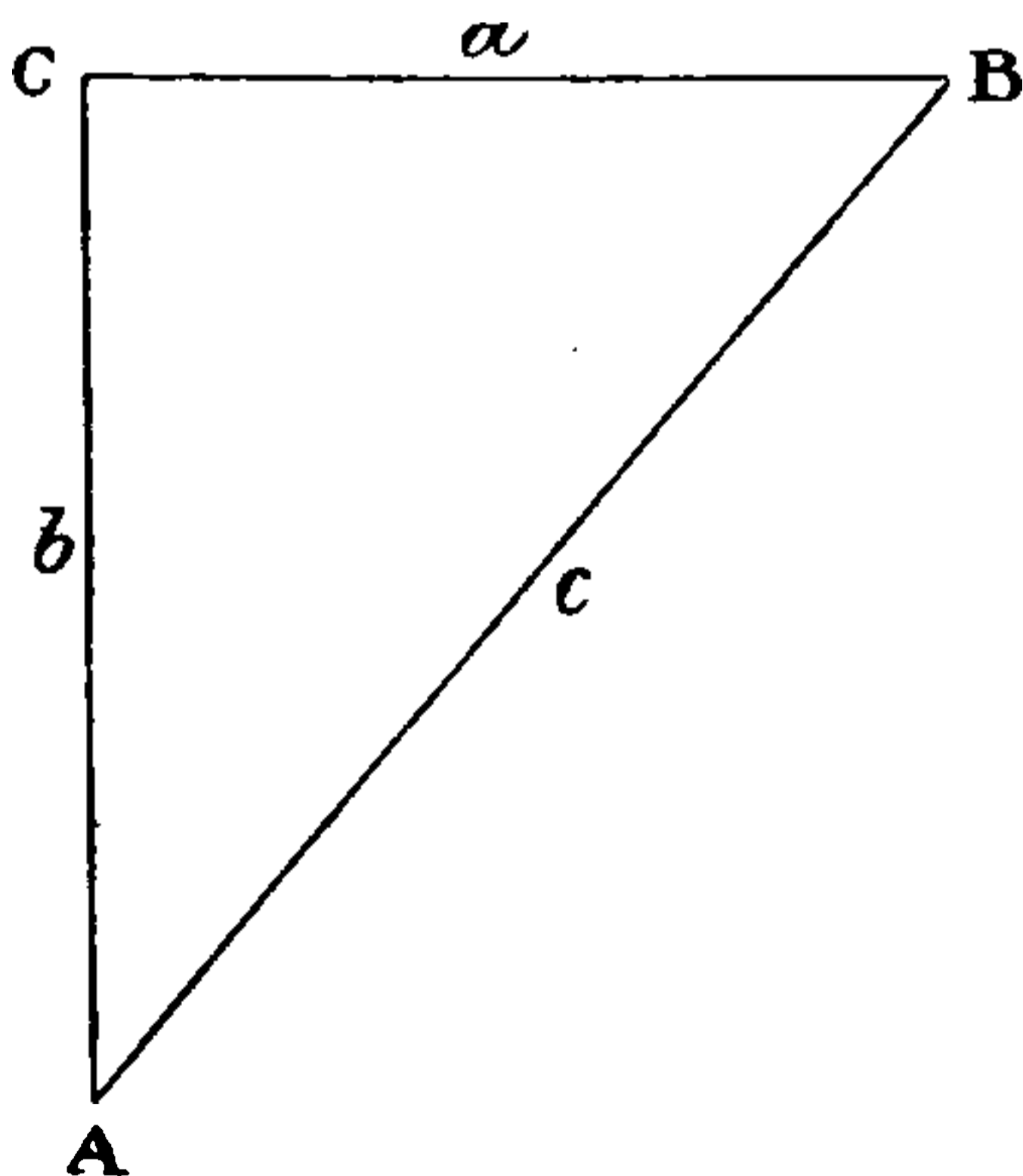

To find two sides, knowing the third side and an angle.
Suppose we know the side a and the angle B in the right-



THIS PAGE IS LOCKED TO FREE MEMBERS

Purchase full membership to immediately unlock this page

SAVE \$3,999,994

Did you know we sell
paperback books too?

To buy our entire catalog
in paperback would cost
over \$4,000,000

Access it all now for
\$8.99/month

*Fair usage policy applies

Continue

2. Supposing sides a and c are known, to find the angles A and B , and the side b .

$$(a) \quad \sin A = \frac{\text{Perpendicular}}{\text{Hypotenuse}} = \frac{a}{c}$$

$$(b) \quad B = 90^\circ - A$$

$$(c) \quad \frac{b}{a} = \frac{\text{Base}}{\text{Perpendicular}} = \cot A$$

$$\text{Therefore } b = a \times \cot A$$

3. Supposing sides b and c are known, to find the angles A and B , and the side a .

$$(a) \quad \cos A = \frac{b}{c}$$

$$(b) \quad B = 90^\circ - A$$

$$(c) \quad \frac{a}{b} = \frac{\text{Perpendicular}}{\text{Base}} = \tan A$$

$$\text{Therefore } a = b \times \tan A$$

4. Supposing side a and angle A are known, to find the angle B and the sides b and c .

$$(a) \quad B = 90^\circ - A$$

$$(b) \quad \frac{b}{a} = \frac{\text{Base}}{\text{Perpendicular}} = \cot A$$

$$\text{Therefore } b = a \times \cot A$$

$$(c) \quad \frac{c}{a} = \frac{\text{Hypotenuse}}{\text{Perpendicular}} = \operatorname{cosec} A$$

$$\text{Therefore } c = a \times \operatorname{cosec} A$$

5. Supposing side b and angle A are known, to find angle B and sides c and a .

$$(a) \quad B = 90^\circ - A$$

$$(b) \quad \frac{a}{b} = \frac{\text{Perpendicular}}{\text{Base}} = \tan A$$

$$\text{Therefore } a = b \times \tan A$$

$$(c) \quad \frac{c}{b} = \frac{\text{Hypotenuse}}{\text{Base}} = \text{Sec } A$$

$$\text{Therefore } c = b \times \text{Sec } A$$

6. Supposing side c and angle A are known, to find angle B and sides a and b .

$$(a) \quad B = 90^\circ - A.$$

$$(b) \quad \frac{a}{c} = \frac{\text{Perpendicular}}{\text{Hypotenuse}} = \text{Sin } A$$

$$\text{Therefore } a = c \times \text{Sin } A$$

$$(c) \quad \frac{b}{c} = \frac{\text{Base}}{\text{Hypotenuse}} = \text{Cos } A$$

$$\text{Therefore } b = c \times \text{Cos } A$$

FIG. 15

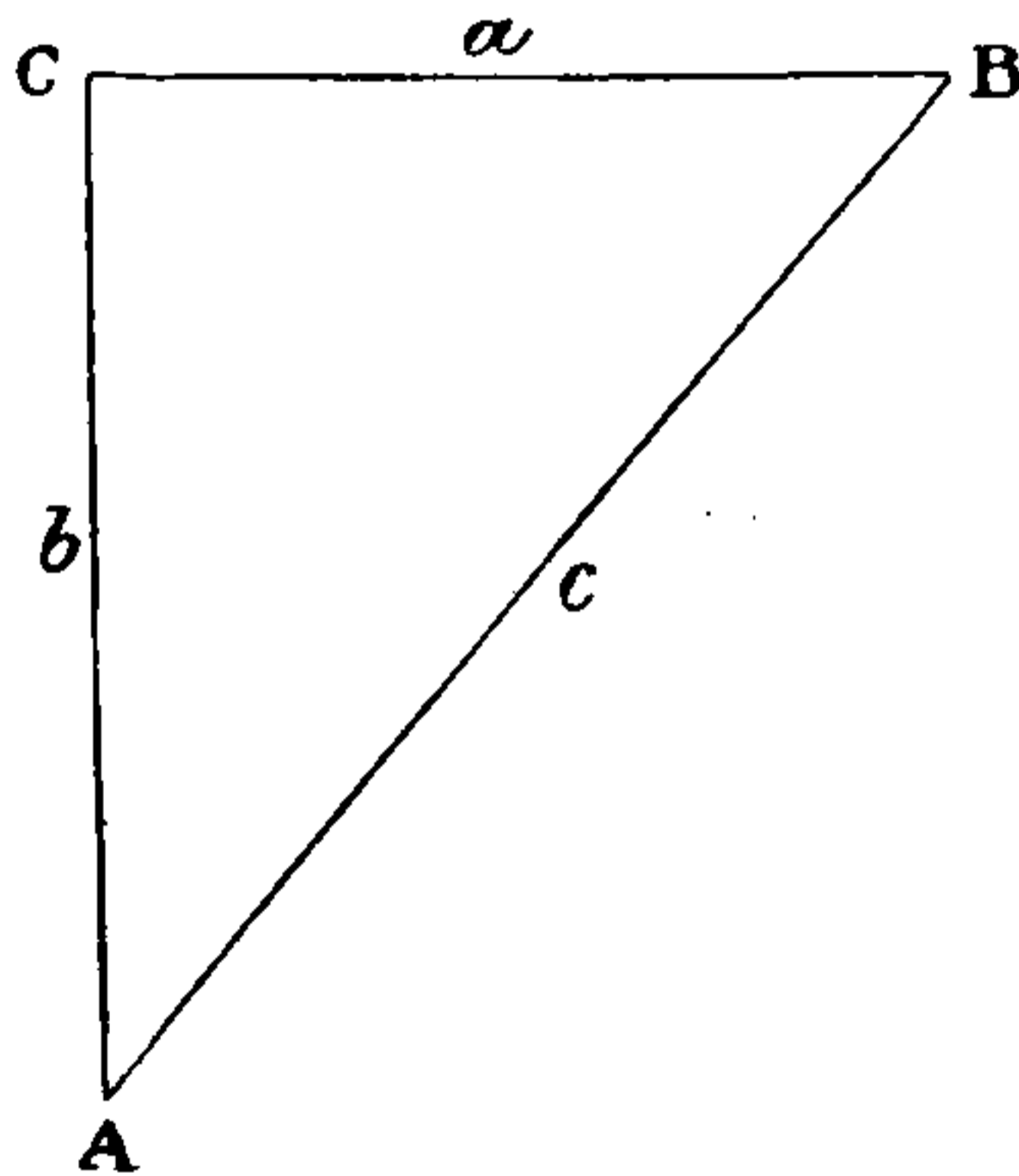

7. Supposing side a and angle B are known, to find the angle A and the sides b and c .

$$(a) \quad A = 90^\circ - B$$

$$(b) \quad \frac{b}{a} = \frac{\text{Perpendicular}}{\text{Base}} = \text{Tan } B$$

$$\text{Therefore } b = a \times \text{Tan } B$$

$$(c) \quad \frac{c}{a} = \frac{\text{Hypotenuse}}{\text{Base}} = \text{Sec } B$$

$$\text{Therefore } c = a \times \text{Sec } B$$

8. Supposing side b and angle B are known, to find the angle A and the sides a and c .

$$(a) \quad A = 90^\circ - B$$

$$(b) \quad \frac{a}{b} = \frac{\text{Base}}{\text{Perpendicular}} = \text{Cot } B$$

$$\text{Therefore } a = b \times \text{Cot } B$$

$$(c) \quad \frac{c}{b} = \frac{\text{Hypotenuse}}{\text{Perpendicular}} = \text{Cosec } B$$

$$\text{Therefore } c = b \times \text{Cosec } B$$

FIG. 15

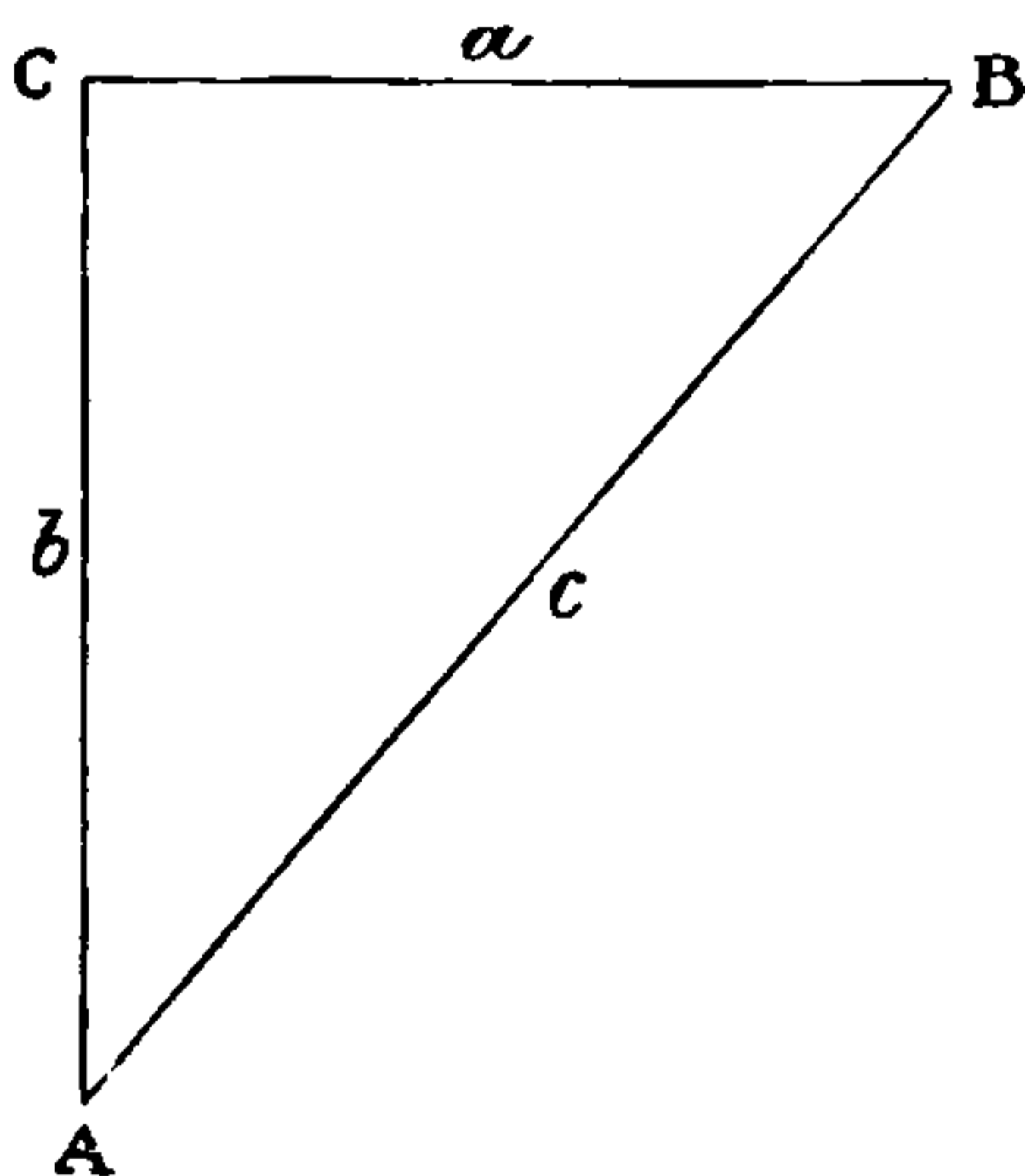

9. Supposing side c and angle B be given, to find the angle A and the sides a and b .

$$(a) \quad A = 90^\circ - B$$

$$(b) \quad \frac{a}{c} = \frac{\text{Base}}{\text{Hypotenuse}} = \text{Cos } B$$

$$\text{Therefore } a = c \times \text{Cos } B$$

$$(c) \quad \frac{b}{c} = \frac{\text{Perpendicular}}{\text{Hypotenuse}} = \text{Sin } B$$

$$\text{Therefore } b = c \times \text{Sin } B$$

As it would be exceedingly cumbersome and inconvenient to multiply and divide the voluminous figures and fractional ratios, Logarithms are always used, as they



THIS PAGE IS LOCKED TO FREE MEMBERS

Purchase full membership to immediately unlock this page

DELVE INTO FANTASY, MAGIC, MYTHOLOGY & FOLKLORE

Forgotten Books'
Full Membership gives
access to 797,885 ancient
and modern, fiction and
non-fiction books.

Continue

*Fair usage policy applies

I have found c in two different ways to show that in using the trigonometrical ratios we are never bound to use any but the most convenient. Let us solve one more triangle.

$$\text{Let } a = 1178, \text{ and } A = 32^\circ 27' 25''$$

To find B

$$A + B = 90^\circ 0' 0''$$

$$A = 32^\circ 27' 25''$$

$$B = 57^\circ 32' 35''$$

To find b

$$\text{Cot } A = \frac{b}{a}$$

$$b = \text{Cot } A \times a$$

$$A = 32^\circ 27' 25'' \text{ Log. Cot } 10.196533$$

$$a = 1178 \text{ Log. } 3.071145$$

$$b = 1852 \text{ nearly. Log. } 3.267678$$

To find c

$$\text{Cosec } A = \frac{c}{a}$$

$$c = \text{Cosec } A \times a$$

$$A = 32^\circ 27' 25'' \text{ Log. Cosec } 10.270297$$

$$a = 1178 \text{ Log. } 3.071145$$

$$c = 2195 \text{ nearly. Log. } 3.341442$$

Solution of Plane Triangles

(Solution of Triangles is required in the Examination for Extra Master.)

Let ABC be a triangle: the angles are called A, B, C respectively, and the sides opposite to them a, b, c , and for shortness the half-sum of the sides, $\frac{a+b+c}{2}$, is called s .

FIG. 16

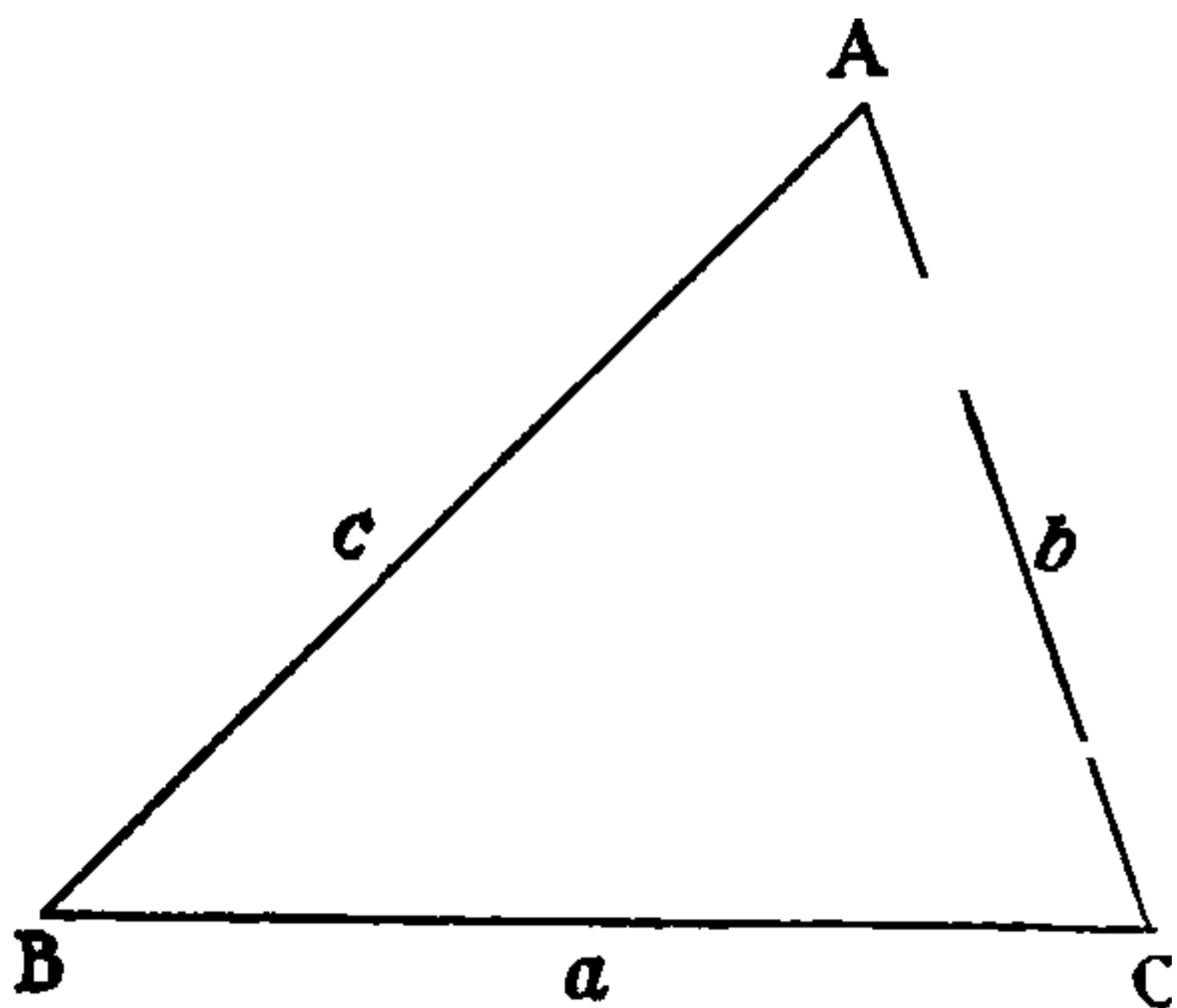

If you know any three of the six quantities, a, b, c, A, B, C , where at least one of the sides is among the three quantities given, you can find the remaining three. This is what is meant by the solution of oblique-angled triangles.

You could, of course, do this roughly by drawing the triangle carefully to scale; but if you want an Extra Master's Certificate you should learn how it is done by Trigonometry.

The different cases which arise are included in the following four. In each case the formula is given, and an example solved.

(1) *Given the three sides of any plane triangle, to find the angles.*

The formula is : $\text{Cos } \frac{A}{2} = \sqrt{\frac{s(s-a)}{bc}}$; or using Logs. :

$$\text{Log. Cos } \frac{A}{2} = \frac{1}{2} \{ \text{Log. } s + \text{Log. } (s-a) - \text{Log. } b - \text{Log. } c \}.$$

In the triangle ABC, $a = 114$, $b = 128$, $c = 212$, find A, B, and C.

First find s , which is half the sum of the three sides.

FIG. 17

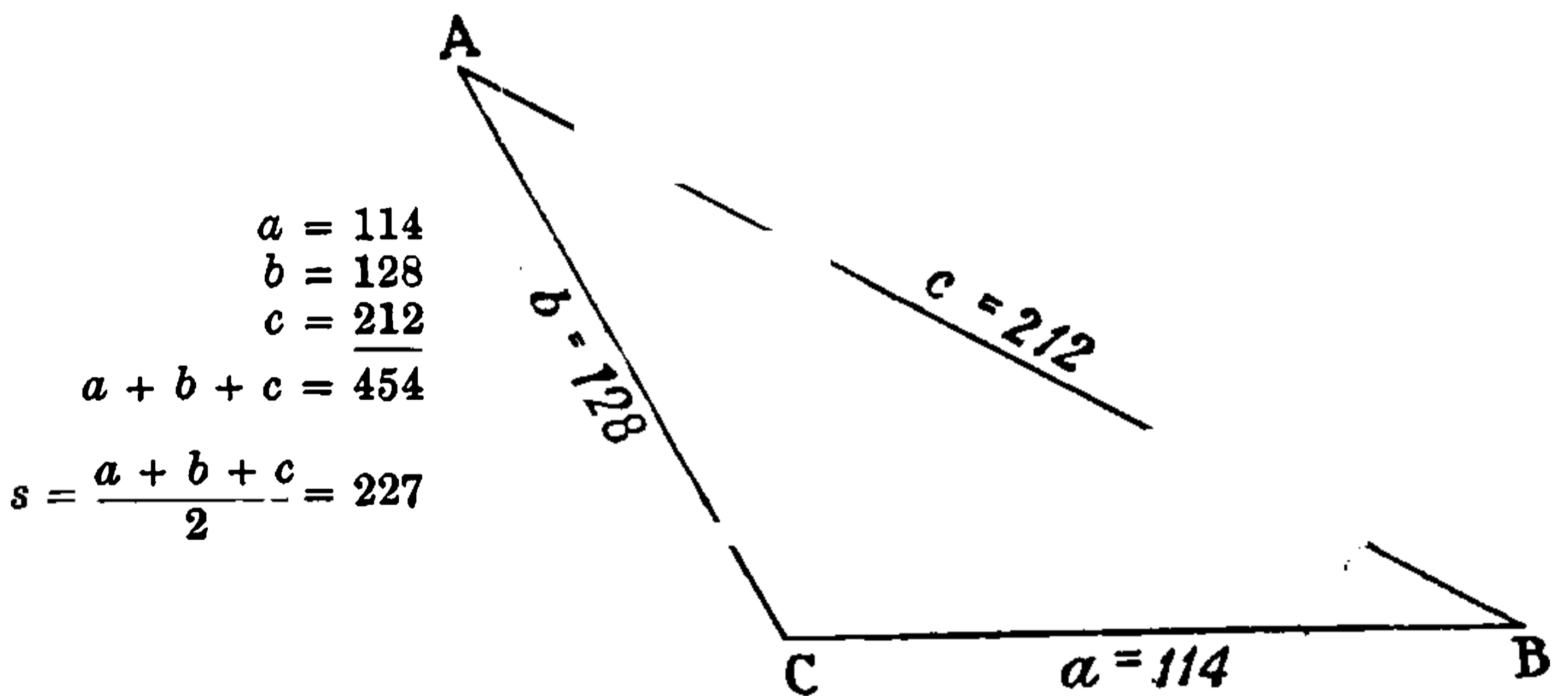

To find the Angle c

$$\text{Log. Cos } \frac{C}{2} = \frac{1}{2} \{ \text{Log. } s + \text{Log. } (s-c) - \text{Log. } a - \text{Log. } b \}$$

$s = 227$	$s = 227$	$\text{Log. } 2.356026$	$a = 114$	$\text{Log. } 2.056905$
$c = 212$	$s - c = 15$	$\text{Log. } 1.176091$	$b = 128$	$\text{Log. } 2.107210$
<hr/>	<hr/>	<hr/>	<hr/>	<hr/>
$s - c = 15$		3.532117		4.164115
		4.164115		
		<hr/>		
		$2) 19.368002$		
		<hr/>		
		$\text{Log. Cos } \frac{C}{2} = 9.684001$	$\frac{C}{2} = 61^\circ 6' 52.5''$	
			<hr/>	
			2	
			<hr/>	
			$c = 122^\circ 13' 45''$	

To find Angle B

$$\text{Cos } \frac{B}{2} = \sqrt{\frac{s(s-b)}{ac}}$$

$$\therefore \text{Log. Cos } \frac{B}{2} = \frac{1}{2} \{ \text{Log. } s + \text{Log. } (s-b) - \text{Log. } a - \text{Log. } c \}$$

$s = 227$	$s = 227$ Log. 2.356026	$a = 114$ Log. 2.056905
$b = 128$	$s - b = 99$ Log. 1.995635	$c = 212$ Log. 2.326336
$s - b = \underline{99}$	4.351661	4.383241

$$\begin{array}{r} 4.383241 \\ 2) \underline{19.968420} \end{array}$$

$$\text{Log. Cos } \frac{B}{2} = 9.984210 \quad \frac{B}{2} = 15^\circ 21' 24.5''$$

$$B = \underline{30^\circ 42' 49''}$$

FIG. 17

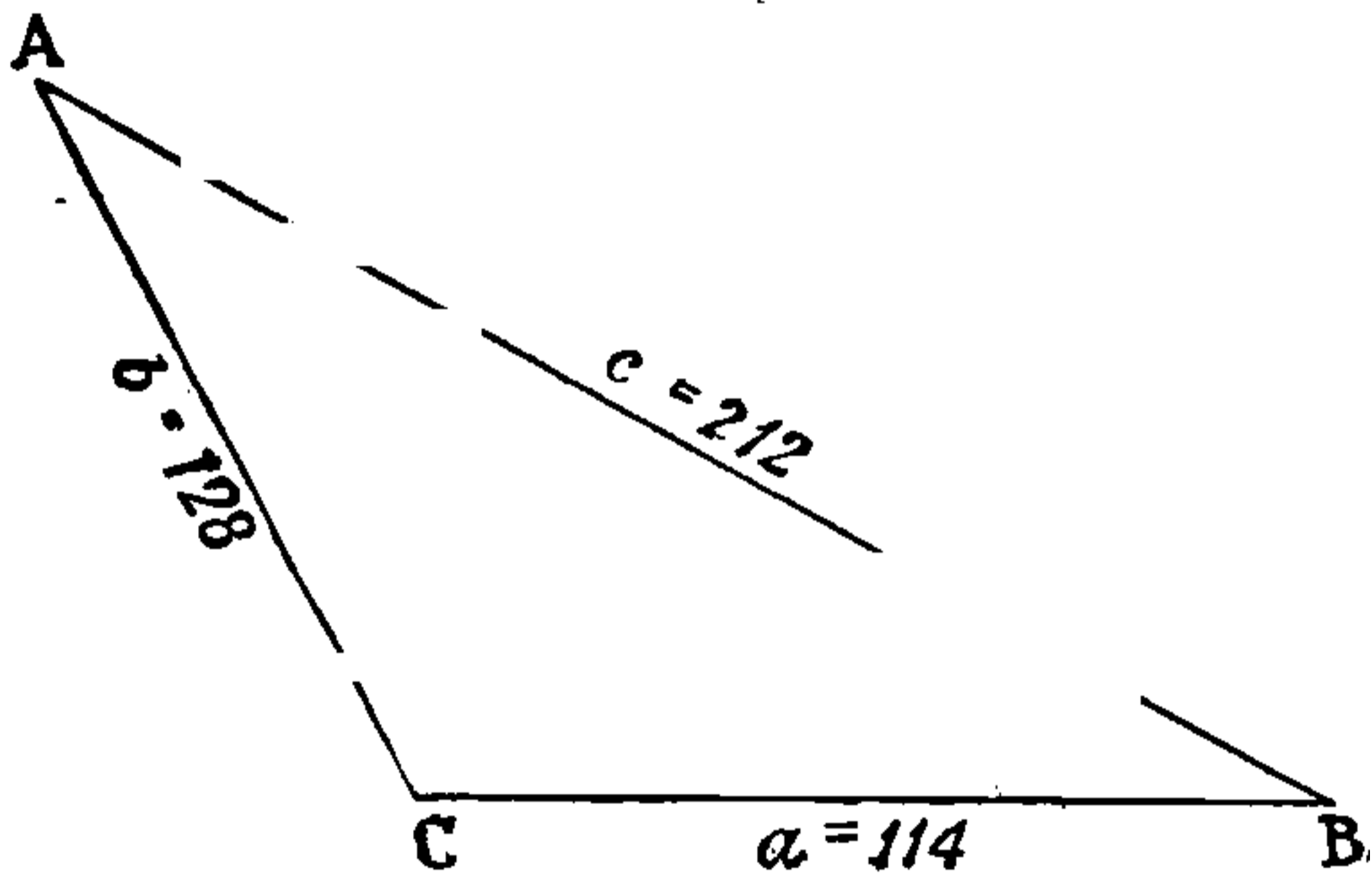

To find Angle A

$$\text{Cos } \frac{A}{2} = \sqrt{\frac{s(s-a)}{bc}}$$

$$\text{Log. Cos } \frac{A}{2} = \frac{1}{2} \{ \text{Log. } s + \text{Log. } (s-a) - \text{Log. } b - \text{Log. } c \}$$

$s = 227$	$s = 227$ Log. 2.356026	$b = 128$ Log. 2.107210
$a = 114$	$s - a = 113$ Log. 2.053078	$c = 212$ Log. 2.326336
$s - a = \underline{113}$	4.409104	4.433546

$$\begin{array}{r} 4.433546 \\ 2) \underline{19.975558} \end{array}$$

$$\text{Log. Cos } \frac{A}{2} = 9.987779 \quad \frac{A}{2} = 13^\circ 31' 43.0''$$

$$A = \underline{27^\circ 3' 26''}$$

Now the three angles of any plane triangle are together equal to 180° , and if the angles found above equal this amount, it proves that the working is correct.

$$\begin{array}{r} c = 122^\circ 13' 45'' \\ B = 30^\circ 42' 49'' \\ A = 27^\circ 3' 26'' \\ \hline A + B + C = 180^\circ 0' 0'' \end{array}$$



THIS PAGE IS LOCKED TO FREE MEMBERS

Purchase full membership to immediately unlock this page

SAVE \$3,999,994

Did you know we sell
paperback books too?

To buy our entire catalog
in paperback would cost
over \$4,000,000

Access it all now for
\$8.99/month

*Fair usage policy applies

Continue

3. Given two sides and the angle opposite to one of them.

FIG. 19



If the given angle is opposite the greater of the two sides, the triangle can be solved as in the preceding case.

Thus in triangle ABC, let $B = 119^\circ 18'$, $b = 11.89$ and $c = 7.21$.

To find c

$$\frac{\sin c}{\sin B} = \frac{c}{b}$$

$$\therefore \sin c = \frac{\sin B \cdot c}{b} = \frac{\sin 119^\circ 18' \times 7.21}{11.89}$$

$$\text{Log. Sin } c = \text{Log. Sin } 119^\circ 18' + \text{Log. } 7.21 - \text{Log. } 11.89$$

$$B = 119^\circ 18' \quad \text{Log. Sin} \quad . \quad 9.940551$$

$$c = 7.21 \quad \text{Log.} \quad . \quad 0.857935$$

$$\hline 10.798486$$

$$b = 11.89 \quad \text{Log} \quad . \quad 1.075182$$

$$\text{Log. Sin } c = \underline{9.723304} \quad c = 31^\circ 55' 31''$$

To find A

$$B = 119^\circ 18' 0''$$

$$C = 31^\circ 55' 31''$$

$$B + C = \underline{151^\circ 13' 31''}$$

$$180^\circ 0' 0''$$

$$A = \underline{28^\circ 46' 29''}$$

$$A = 180^\circ - (B + C)$$

$$= 180^\circ - (119^\circ 18' + 31^\circ 55' 31'')$$

$$= 28^\circ 46' 29''$$

To find a

$$\frac{a}{b} = \frac{\sin A}{\sin B}$$

$$\therefore a = \frac{b \cdot \sin A}{\sin B} = b \cdot \sin A \cdot \text{Cosec } B$$

$$\text{because } \frac{1}{\sin B} = \text{Cosec } B$$

$$\therefore \text{Log. } a = \text{Log. } b + \text{Log. Sin } A + \text{Log. Cosec } B - 20$$

$$b = 11.89 \quad \text{Log.} \quad . \quad 1.075182$$

$$A = 28^\circ 46' 29'' \quad \text{Log. Sin} \quad . \quad 9.682476$$

$$B = 119^\circ 18' 0'' \quad \text{Log. Cosec} \quad 10.059449$$

$$\text{Log. } a = \underline{0.817107}$$

$$a = 6.563 \text{ very nearly}$$

In working this problem you must bear in mind that the greater angle is always opposite the greater side; and that $\sin A = \sin (180^\circ - A)$, so that every Log. Sine in Table XXV. represents two angles which are supplements of one another. You must take the greater value if it is necessary, in order that the greater angle may be opposite the greater side.

In the previous example the known angle was opposite the greater of the given sides, and only one solution was possible. But in the event of the angle given being opposite to the less given side, there are two solutions, and this state of affairs is known as the ambiguous case.

FIG. 20

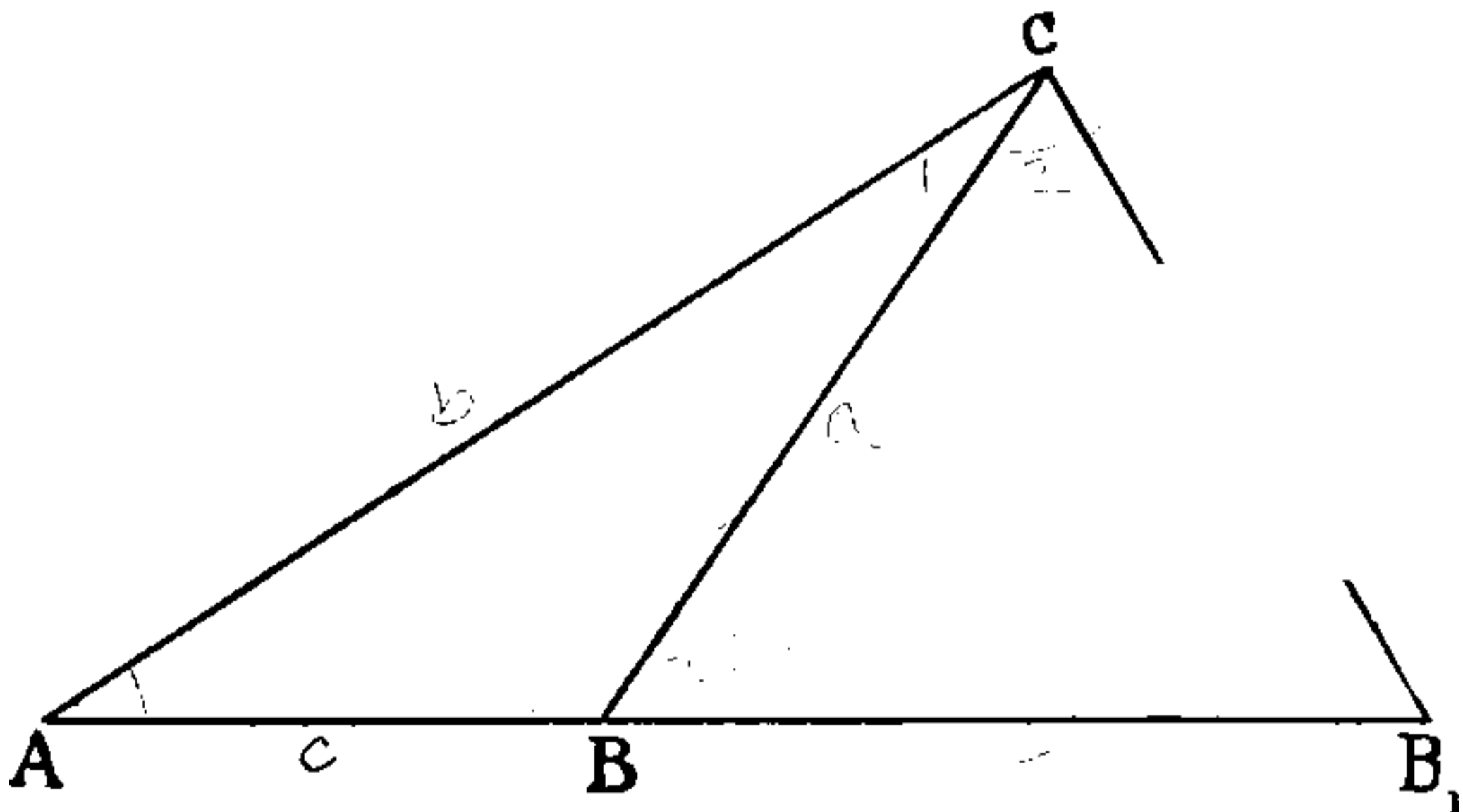

For instance, in the plane triangle ABC , let $A = 31^\circ 28'$, $a = .564$, and $b = .9$. Make $CB_1 = CB$. We now have two triangles, ABC and AB_1C , in which the angle A and the sides a and b are equal.

There are therefore two values for the angles C and B , and for the side c . Now with regard to angles B and B_1 ; Euclid tells us that the angles at the base of an isosceles triangle are equal. An isosceles triangle is a triangle which has two of its sides equal to one another. CB and CB_1 are equal to one another, and therefore CB_1B is an isosceles triangle, and the angles CB_1B and CB_1C at its base are also equal. Angle CB_1C is the supplement of

angle $A B C$, and therefore angle $C B_1 B$ is also the supplement of angle $A B C$. Angle B in the triangle $A B C = 180^\circ - \text{angle } B_1$; and if you can find B_1 , you will know B , which is its supplement.

To find B_1

$$\frac{\sin B_1}{\sin A} = \frac{b}{a}$$

$$\therefore \sin B_1 = \frac{b \cdot \sin A}{a}$$

$$\text{Log. Sin } B_1 = \text{Log. } b + \text{Log. Sin } A - \text{Log. } a$$

$$b = .9 \quad \text{Log.} \quad . \quad 9.954243$$

$$A = 31^\circ 28' \quad \text{Log. Sin} \quad . \quad 9.717673$$

$$\hline 19.671916$$

$$a = .564 \quad \text{Log.} \quad . \quad 9.751279$$

$$\text{Log. Sin } B_1 = 9.920637 \quad B_1 = 56^\circ 24' 23.5''$$

FIG. 20

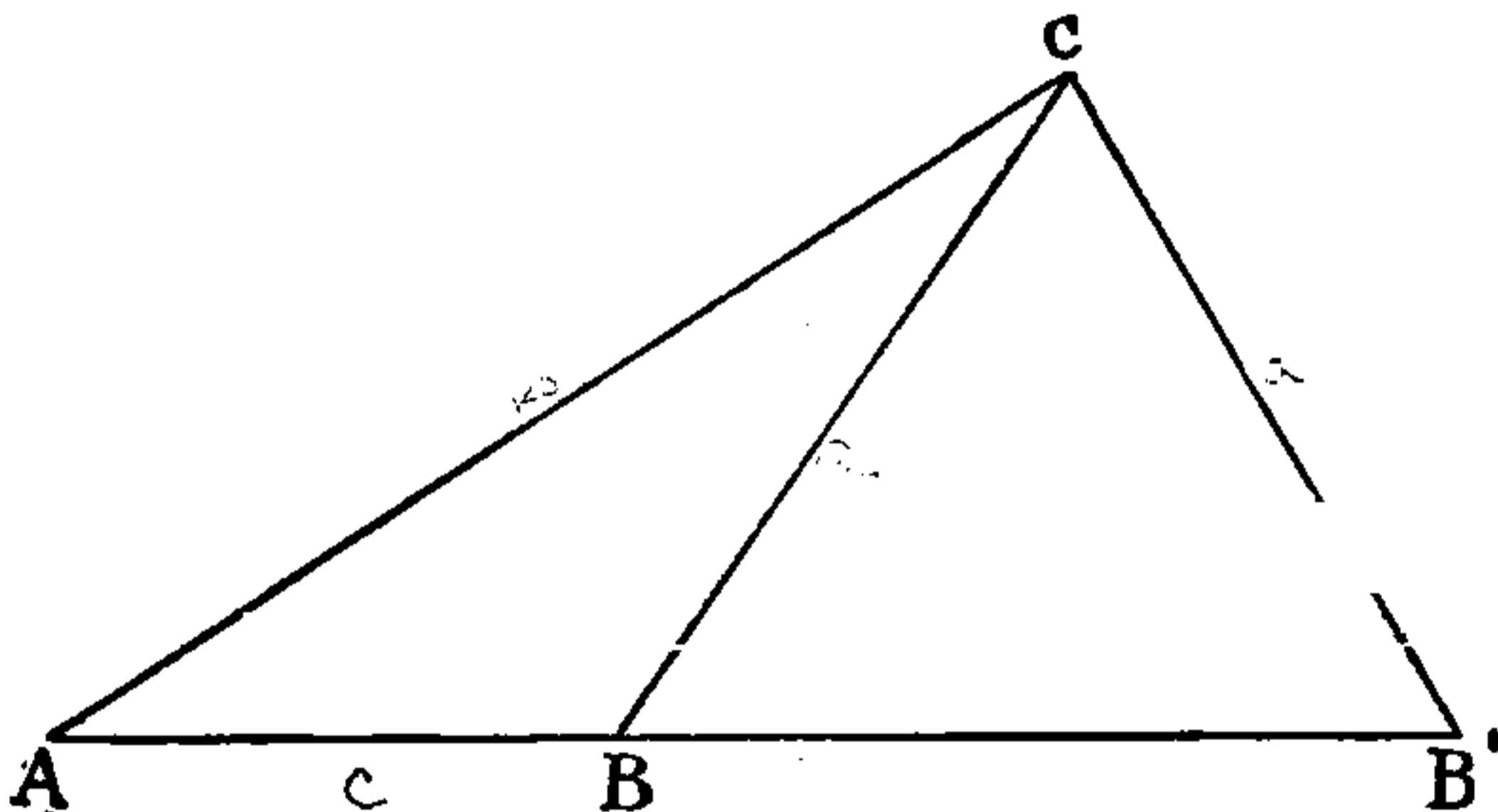

In the triangle $A B_1 C$, B_1 is $56^\circ 24' 23.5''$. B in the triangle $A B C$ is the supplement of B_1 , therefore $B = 180^\circ - B_1 = 180^\circ - 56^\circ 24' 23.5'' = 123^\circ 35' 36.5''$.

You have now the values of B and B_1 , or the two values of B . Let us next get the two values of angle c , that is the angles $A C B$ and $A C B_1$.

In the triangle $A B C$ you know the angles A and B , but $c = 180^\circ - (A + B) = 180^\circ - (31^\circ 28' + 123^\circ 35' 36.5'')$

$$A = 31^\circ 28' 0''$$

$$B = 123^\circ 35' 36.5''$$

$$A + B = 155^\circ 3' 36.5''$$

$$\hline 180^\circ 0' 0''$$

$$\text{In triangle } A B C, c = 24^\circ 56' 23.5''$$



THIS PAGE IS LOCKED TO FREE MEMBERS

Purchase full membership to immediately unlock this page

DELVE INTO FANTASY, MAGIC, MYTHOLOGY & FOLKLORE

Forgotten Books'
Full Membership gives
access to 797,885 ancient
and modern, fiction and
non-fiction books.

Continue

*Fair usage policy applies

4. Given two sides and the included angle, to find the other parts.

In the triangle ABC , let $A = 31^\circ 28'$, $b = 900$, and $c = 455.6$. To find the other parts.

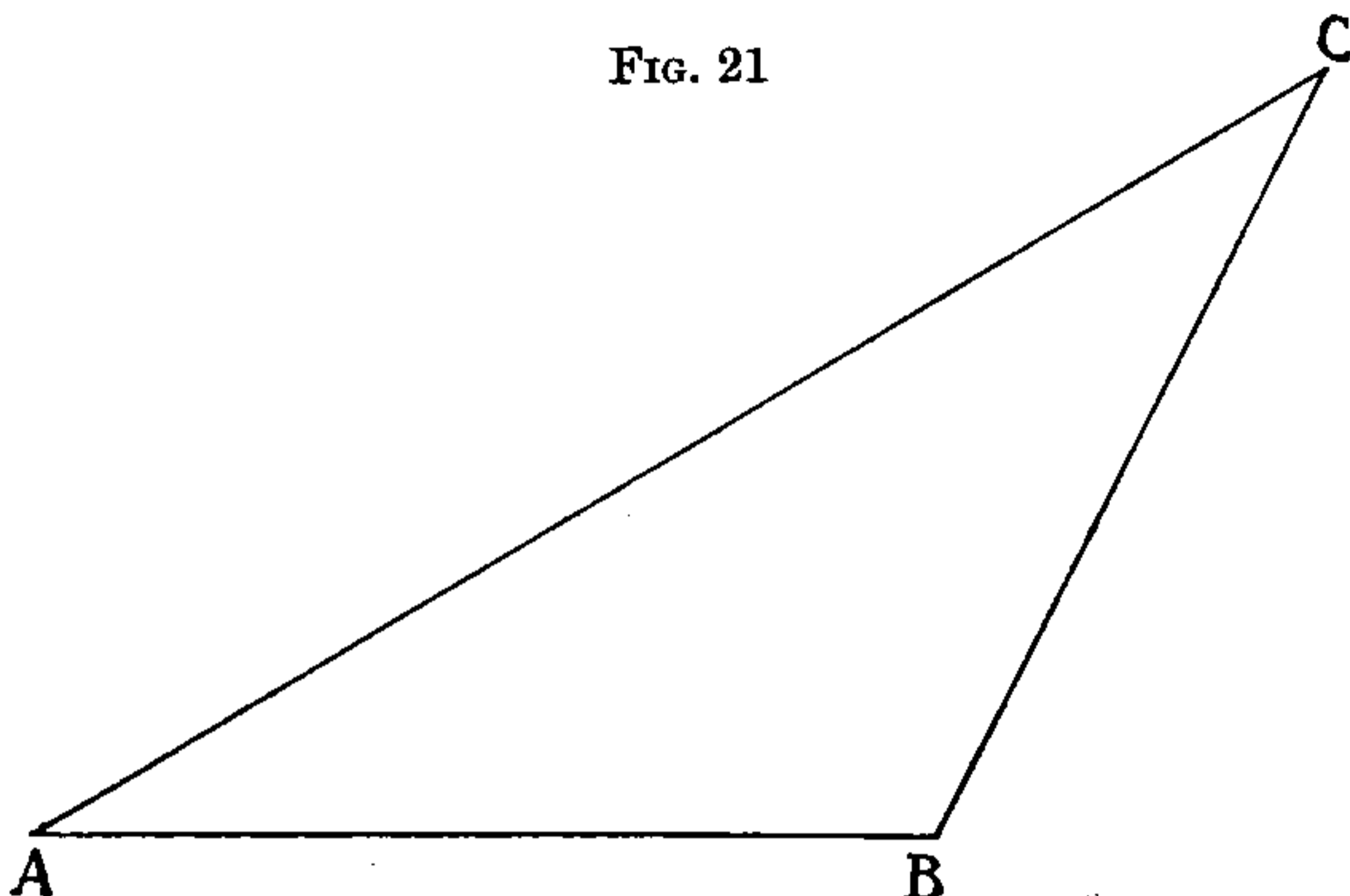

We first find the two remaining angles by using the following formula :

$$\tan \frac{1}{2} (B - C) = \frac{b - c}{b + c} \cot \frac{A}{2}$$

$$\therefore \text{Log. Tan } \frac{1}{2} (B - C) = \text{Log. } (b - c) + \text{Log. Cot } \frac{A}{2} - \text{Log. } (b + c)$$

$A = 31^\circ 28' 0''$	$b = 900$	$b = 900$
$\frac{A}{2} = 15^\circ 44' 0''$	$c = 455.6$	$c = 455.6$
	$b + c = 1355.6$	$b - c = 444.4$

$b - c = 444.4$	Log.	. 2.647774
-----------------	------	------------

$\frac{A}{2} = 15^\circ 44' 0''$	Log. Cot.	10.550190
----------------------------------	-----------	-----------

		13.197964
$b + c = 1355.6$	Log.	3.132132

$$\text{Log. Tan } \frac{1}{2} (B - C) = 10.065832 \quad \frac{1}{2} (B - C) = 49^\circ 19' 34''$$

$$\text{Now as } B + C = 180^\circ - A \quad \therefore \frac{1}{2} (B + C) = \frac{1}{2} (180^\circ - A)$$

$180^\circ 0' 0''$
$A = 31^\circ 28' 0''$
$B + C = 148^\circ 32' 0''$
$\frac{1}{2} (B + C) = 74^\circ 16' 0''$

$$\text{And } \frac{1}{2} (B + C) + \frac{1}{2} (B - C) = \frac{1}{2} B + \frac{1}{2} C + \frac{1}{2} B - \frac{1}{2} C = B$$

$$\text{also } \frac{1}{2} (B + C) - \frac{1}{2} (B - C) = \frac{1}{2} B + \frac{1}{2} C - \frac{1}{2} B + \frac{1}{2} C = C$$

$\frac{1}{2} (B + C) = 74^\circ 16' 0''$	$\frac{1}{2} (B + C) = 74^\circ 16' 0''$
$\frac{1}{2} (B - C) = 49^\circ 19' 34''$	$\frac{1}{2} (B - C) = 49^\circ 19' 34''$
$B = 123^\circ 35' 34''$	$C = 24^\circ 56' 26''$

Now to find a

$$\frac{a}{b} = \frac{\sin A}{\sin B} \quad \therefore a = \frac{b \cdot \sin A}{\sin B}$$

$$\text{Log. } a = \text{Log. } b \times \text{Log. } \sin A \times \text{Log. } \text{Cosec } B$$

$$b = 900 \quad \text{Log.} \quad . \quad . \quad 2.954243$$

$$A = 31^\circ 28' 0'' \quad \text{Log. Sin} \quad . \quad . \quad 9.717673$$

$$B = 123^\circ 35' 34'' \quad \text{Log. Cosec.} \quad . \quad 10.079360$$

$$\text{Log. } a = 2.751276 \quad a = 563.996$$

And so the triangle is solved, the parts found being

$$B = 123^\circ 35' 34''$$

$$c = 24^\circ 56' 26''$$

$$a = 563.996$$

If you commit to memory the following formulas, and accustom yourself to working them as above, you can solve any plane triangle, always remembering that the larger side must be opposite the larger angle; and that when two sides and the angle opposite the less side are given there are two solutions because two triangles fulfil the conditions.

$$1. \quad \frac{a}{\sin A} = \frac{b}{\sin B} = \frac{c}{\sin C}$$

$$2. \quad \cos \frac{A}{2} = \sqrt{\frac{s(s-a)}{bc}} \quad \text{where } s = \frac{1}{2}(a+b+c)$$

$$3. \quad \tan \frac{B-C}{2} = \frac{b-c}{b+c} \cot \frac{A}{2}$$

Some examples are given in the exercises at the end of Vol. II. which, if you wish to obtain an Extra Master's Certificate, it would be well to work.

Explanation of Formulas used in the Sailings

With the help of the little Trigonometry in this chapter it is easy to see the reason for the formulas used in the Sailings.

Plane Sailing.—Let A be the position on the Meridian N S from which a ship starts, and B the place at which she arrives.

FIG. 22

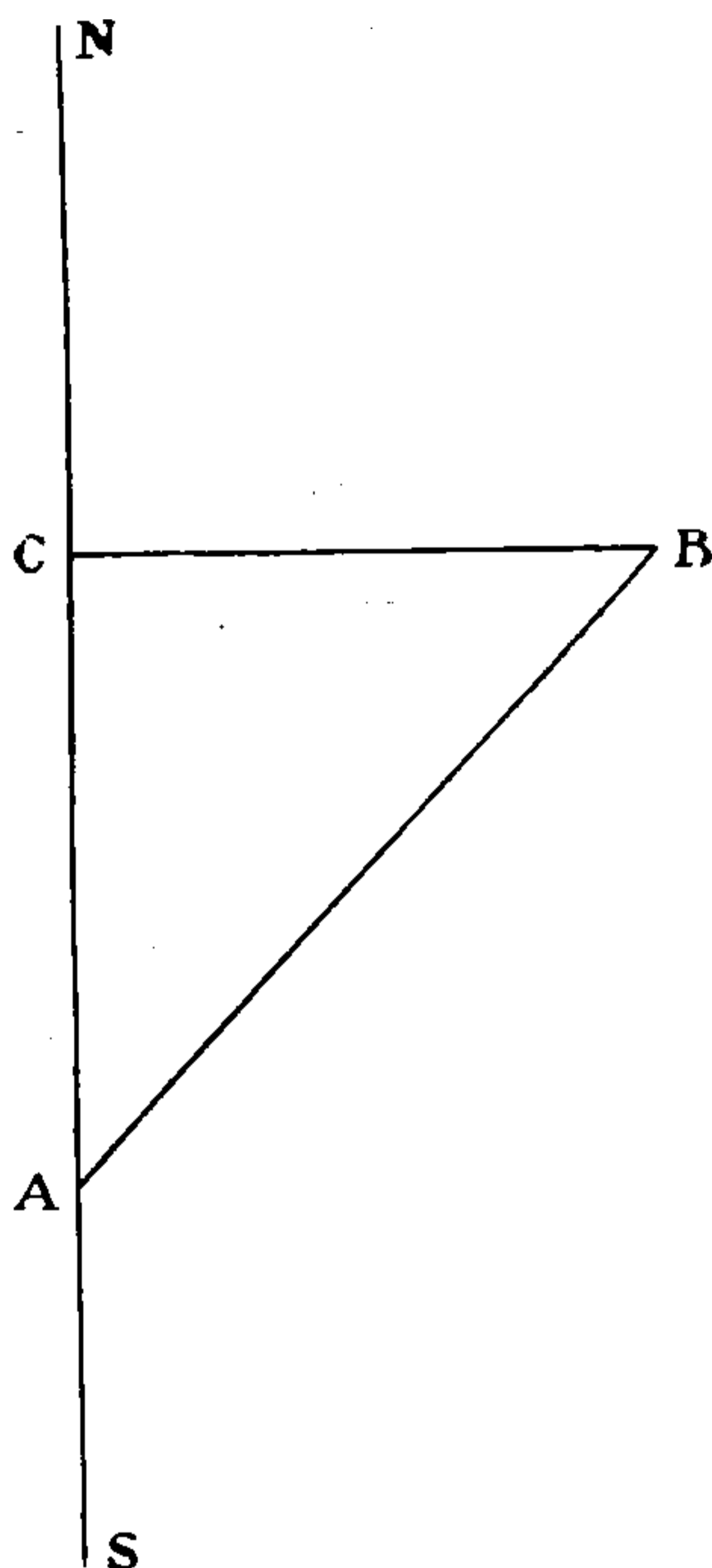

The line A B represents the Distance.

The angle N A B „ „ Course.

The line A C „ „ Difference of Latitude (unknown).

The line C B „ „ Departure (unknown).

Therefore in the right-angled triangle A C B you know the angle C A B and the side A B, and wish to find the sides A C and C B.

$$\text{Now } \cos C A B = \frac{\text{Base}}{\text{Hypotenuse}} = \frac{A C}{A B} = \frac{\text{Diff. Lat.}}{\text{Distance}}$$



THIS PAGE IS LOCKED TO FREE MEMBERS

Purchase full membership to immediately unlock this page

SAVE \$3,999,994

Did you know we sell
paperback books too?

To buy our entire catalog
in paperback would cost
over \$4,000,000

Access it all now for
\$8.99/month

*Fair usage policy applies

Continue

Longitude. The rules given on pp. 91–92 are founded on the following formulas :

(1) Difference of Longitude = Departure \times Secant Latitude.

(2) Departure = Difference of Longitude \times Cosine Latitude. To obtain these formulas draw a figure in

FIG. 23

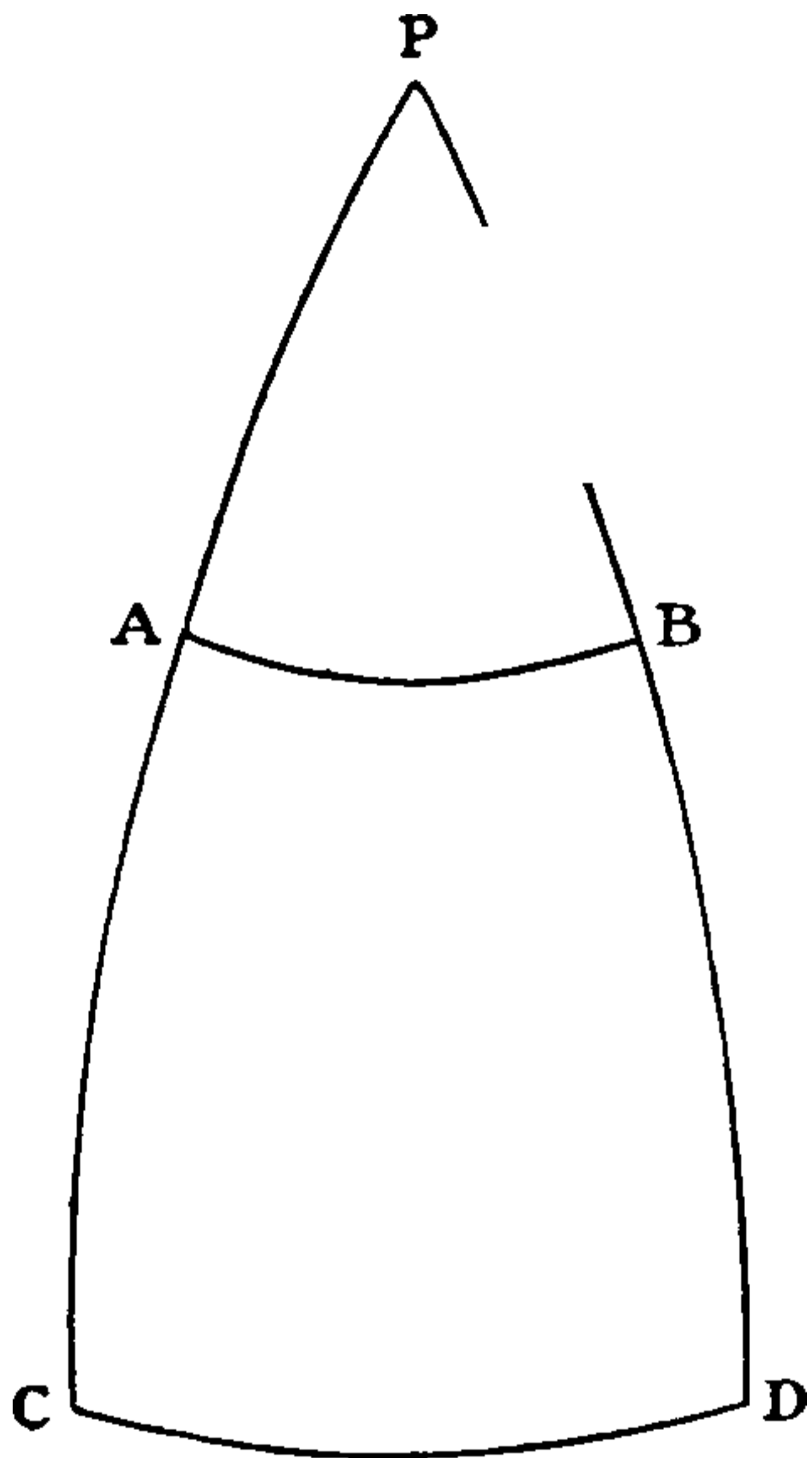

which P is the Pole; and PC and PD the two Meridians. Let AB be the Parallel of Latitude upon which you have sailed from A to B. Let CD be a portion of the Equator between the two Meridians PC and PD, then CD is the Difference of Longitude due to your Departure AB. In any sphere, as will be proved in the next paragraph, the arc CD of a Great Circle, divided by the arc AB of a Small Circle, enclosed between the same Meridians and parallel to the Great Circle, is equal to the Secant

of the arc AC, which is the Latitude. Or in Equational form :

$$\frac{CD}{AB} = \text{Secant Arc AC.}$$

or
$$\frac{\text{Diff. Long.}}{\text{Departure}} = \text{Secant Latitude ;}$$

and multiplying both sides by Departure, we have Difference of Longitude = Departure \times Secant Latitude ; and by Logarithms,

$$(1) \text{ Log. Sec Lat. } + \text{ Log. Dep. } = \text{ Log. Diff. Long.}$$

If we knew the Diff. Long., and wished to find the Departure, we should transpose Log. Sec Lat. to the other side of the equation, giving us the formula,

$$(2) \text{ Log. Dep.} = \text{Log. Diff. Long.} - \text{Log. Sec Lat.}$$

and since Secant is the same as $\frac{1}{\text{Cosine}}$ we can write this formula

$$\text{Log. Dep.} = \text{Log. Diff. Long} + \text{Log. Cos Lat.}$$

To show that $\frac{CD}{AB} = \text{Secant Arc } AC$ in Fig. 23, draw a figure in which the parallel AB and the part of the Equator CD are extended to go all round the Earth. Let o be the Centre of the Earth and k the Centre of the Parallel on which we are sailing.

FIG. 24

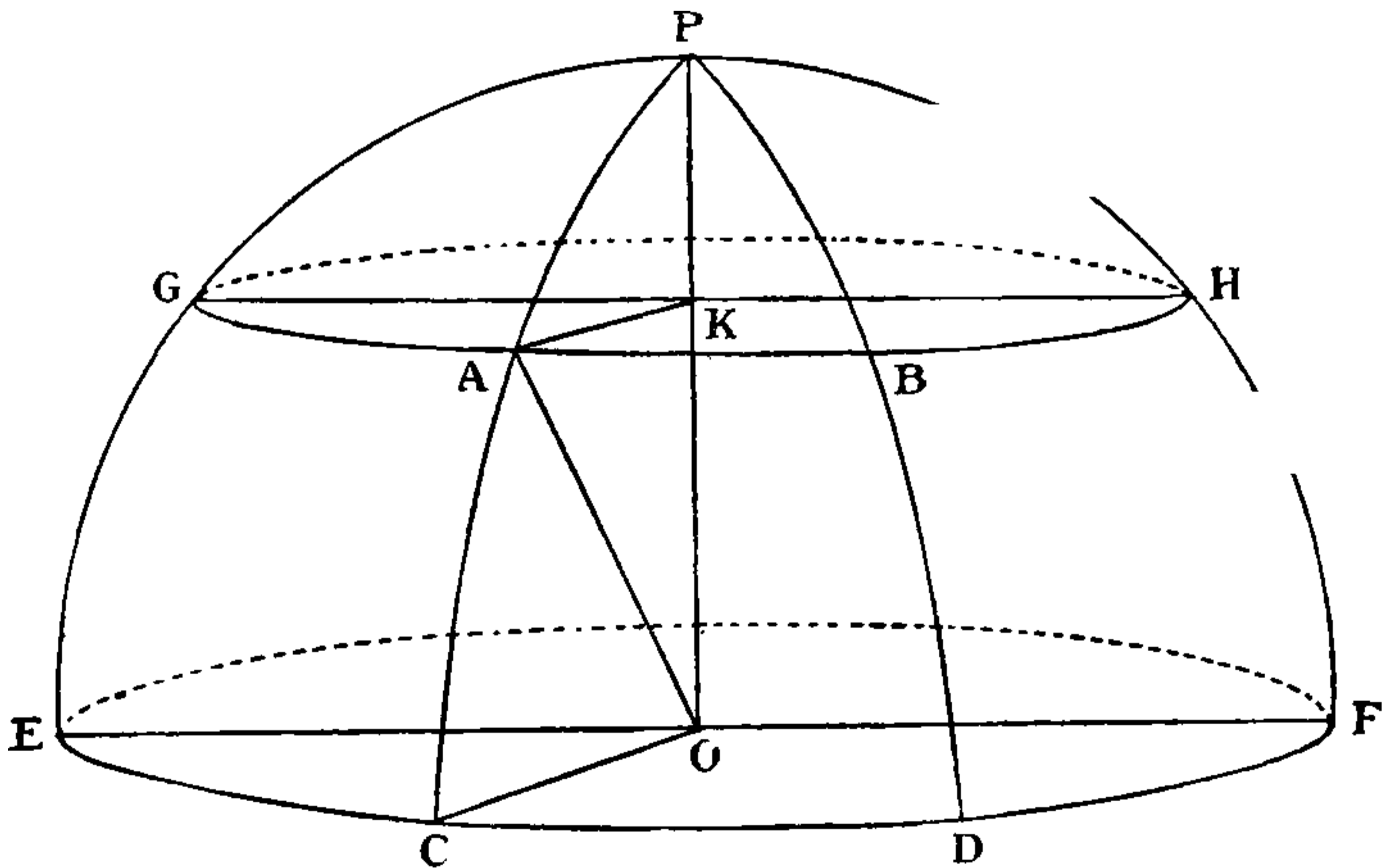

Then AB is the same fraction of the whole parallel as CD is of the whole Equator.

$$\text{Therefore } \frac{CD}{AB} = \frac{\text{Circum. of Circle } E C D F}{\text{Circum. of Circle } G A B H}$$

Further, the circumferences of two circles have the same ratio to one another that their radii have; and the radii of these two circles are KA and CO respectively.

Thus
$$\frac{CD}{AB} = \frac{CO}{AK}$$

Now $OA = OC$, since all points on the Earth's surface are at the same distance from the centre. Also the angle AKO is a right angle.

Therefore
$$\frac{CO}{AK} = \frac{OA}{AK} = \text{Cosec } \angle AOK = \text{Cosec Arc } AP$$

FIG. 24

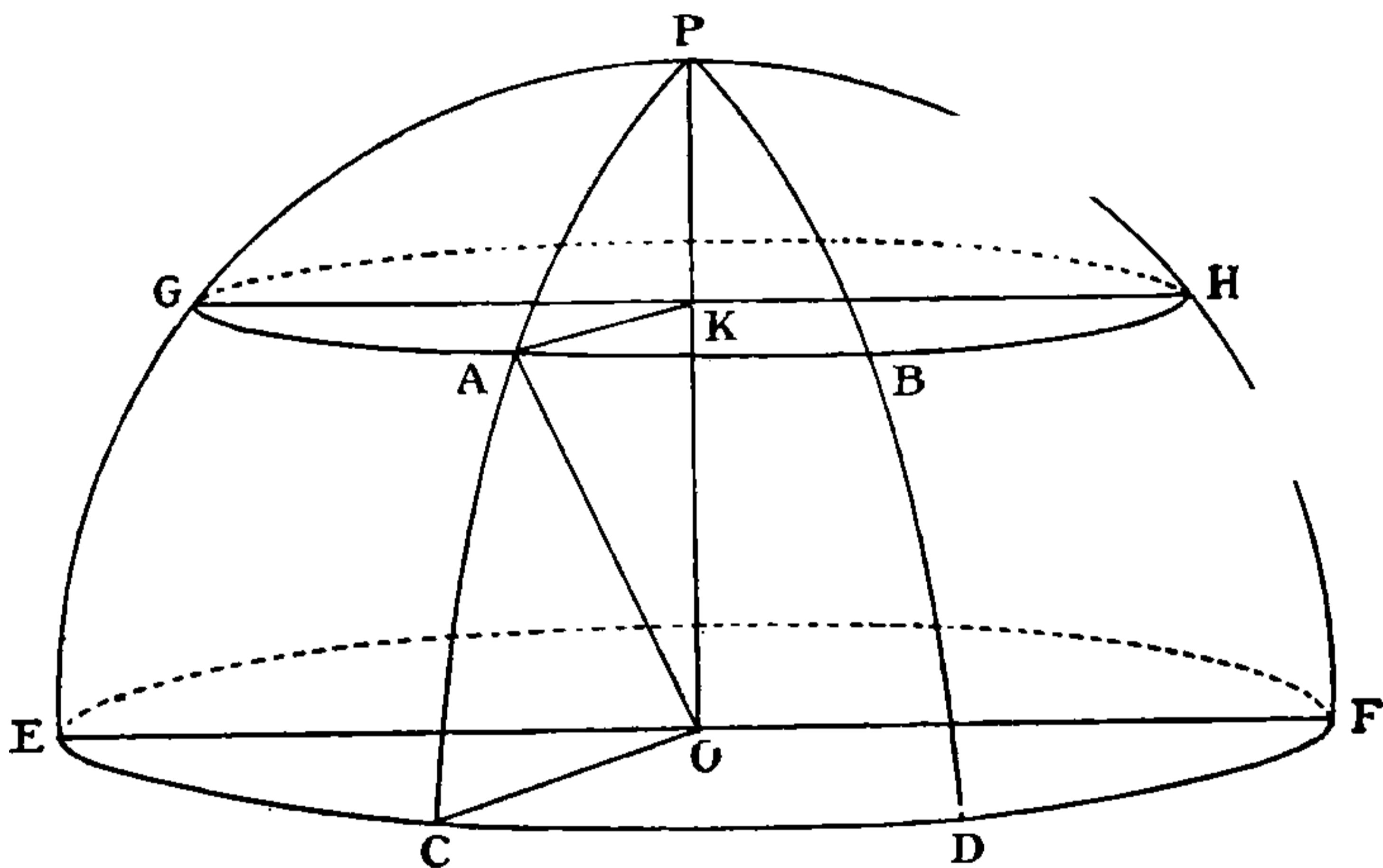

And since $\text{Arc } AP + \text{Arc } CA = 90^\circ$

$$\begin{aligned} \text{Cosec Arc } AP &= \text{Sec Arc } AC \\ &= \text{Sec Lat.} \end{aligned}$$

Therefore
$$\frac{CD}{AB} = \text{Sec Lat. and conversely}$$

$$\frac{AB}{CD} = \text{Cos Lat.}$$

And since AB is the Departure corresponding to the Diff. Long. CD , we obtain the formulas given above.



THIS PAGE IS LOCKED TO FREE MEMBERS

Purchase full membership to immediately unlock this page

DELVE INTO FANTASY, MAGIC, MYTHOLOGY & FOLKLORE

Forgotten Books'
Full Membership gives
access to 797,885 ancient
and modern, fiction and
non-fiction books.

Continue

*Fair usage policy applies

The solution of a Middle Latitude problem by means of the Traverse Tables is exemplified in the Sailings.

Mercator's Sailing.—The meaning of the formulas employed in Mercator's Sailing can be best explained by the help of a diagram.

FIG. 26

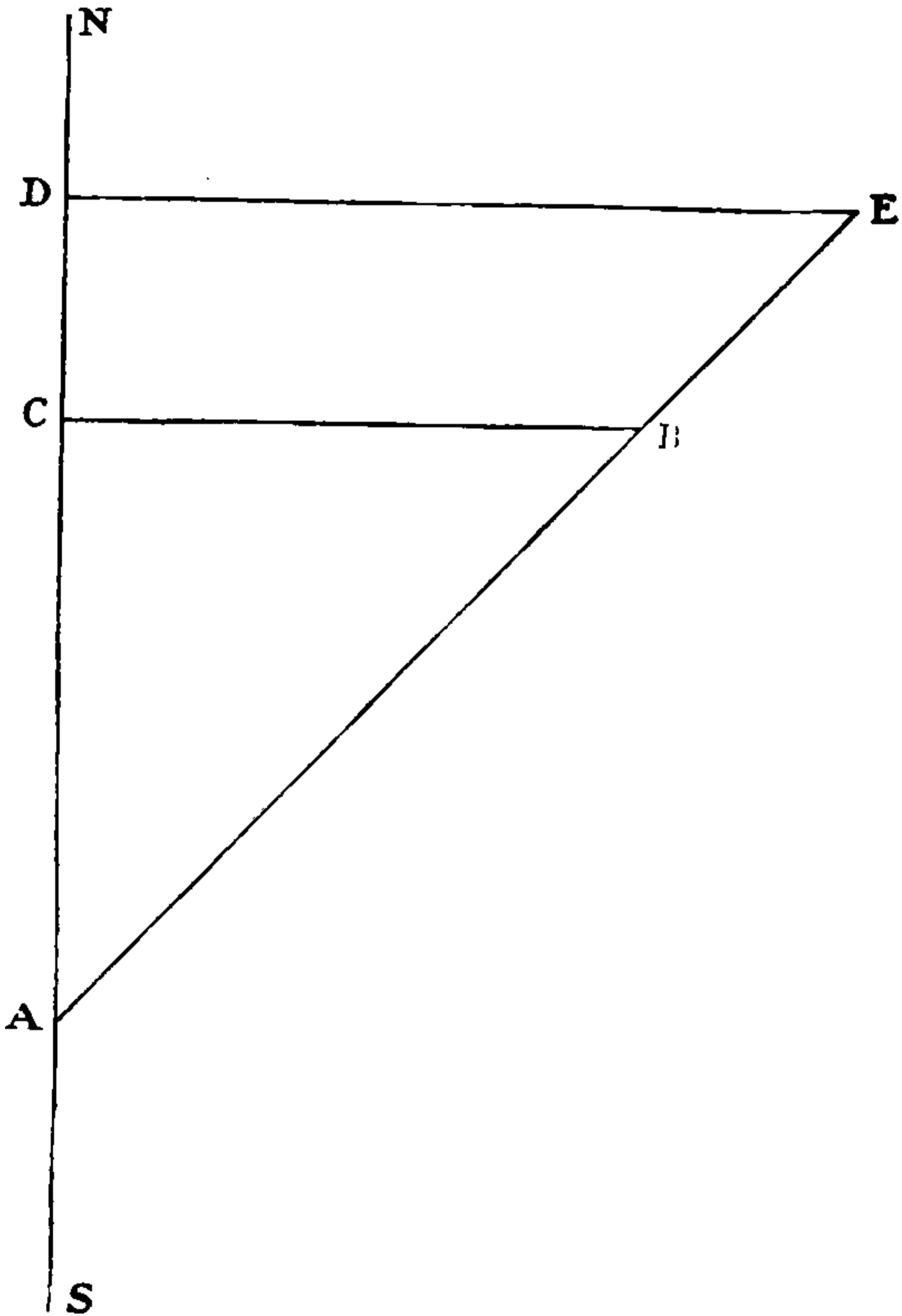

In the above diagram let Ns be a Meridian, A and B two places on the earth's surface, AC the Difference of Latitude, BC the Departure, and CAB the Course. Now in a Mercator's Chart the Parallels of Latitude are drawn

too far apart in the same proportion as the distance between the Meridian is exaggerated in order that they may be drawn parallel to one another; and the distance between two such Parallels is called the Meridional Difference of Latitude. Let $A D$ represent this exaggerated Meridional Difference of Latitude; then $D E$ drawn parallel to $C B$ and cutting $A B$ extended at E will represent the Difference of Longitude, because (see chapter on Charts) as Departure is to Difference of Latitude, so is Difference of Longitude to Meridional Difference of Latitude.

Here, then, we have two right-angled triangles $C A B$ and $D A E$ having an angle A common to each. By right-angled Plane Trigonometry:

$$(i.) \tan A = \frac{\text{Perp.}}{\text{Base}} = \frac{D E}{A D} = \frac{\text{Diff. Long.}}{\text{Mer. Diff. Lat.}}$$

Therefore

$$\tan \text{Course} = \frac{\text{Diff. Long.}}{\text{Mer. Diff. Lat.}}$$

$$(ii.) \sec A = \frac{\text{Hyp.}}{\text{Base}} = \frac{A B}{A C} = \frac{\text{Dist.}}{\text{Diff. Lat.}}$$

Therefore

$$\text{Dist.} = \text{Diff. Lat.} \times \sec \text{Co.}$$

The formulas used in the 'Day's Work' problems are identical with those in Plane Sailing and in Parallel Sailing.

Theory of the Traverse Tables

In questions relating to the Sailings there is always the alternative of using the Trigonometrical formulas or of using the Traverse Tables. The Traverse Tables are not so accurate as the Trigonometrical formulas, but are much quicker, and being quite accurate enough are to be preferred, and are universally used.

In the diagram AB is the distance, the angle CAB the Course, AC the Difference of Latitude, and BC the Departure. The Traverse Tables give the values of AC and BC corresponding to all values of the angle CAB from 1° to 89° , and to all lengths of AB from 1 to 300.

FIG. 27

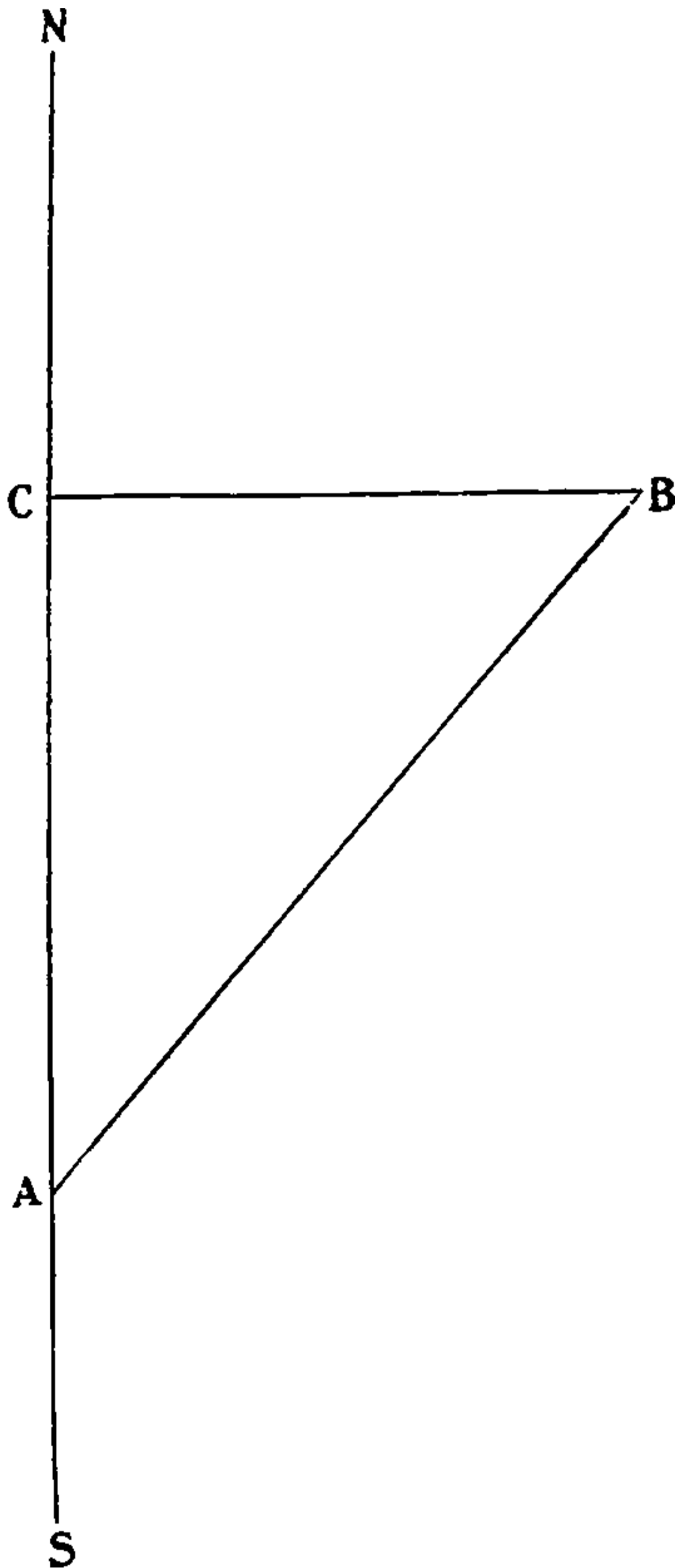

The application of the Traverse Tables to Plane Sailing requires no further explanation, but the use of the Traverse Tables is much more extensive than this. In fact, any problem in right-angled Plane Trigonometry



THIS PAGE IS LOCKED TO FREE MEMBERS

Purchase full membership to immediately unlock this page

SAVE \$3,999,994

Did you know we sell
paperback books too?

To buy our entire catalog
in paperback would cost
over \$4,000,000

Access it all now for
\$8.99/month

*Fair usage policy applies

Continue

In Mercator's Sailing the formulas are

$$(1) \text{ Tan Co.} = \frac{\text{Diff. Long.}}{\text{Mer. Diff. Lat.}}$$

$$(2) \text{ Dist.} = \text{Diff. Lat.} \times \text{Sec Co.}$$

FIG. 27

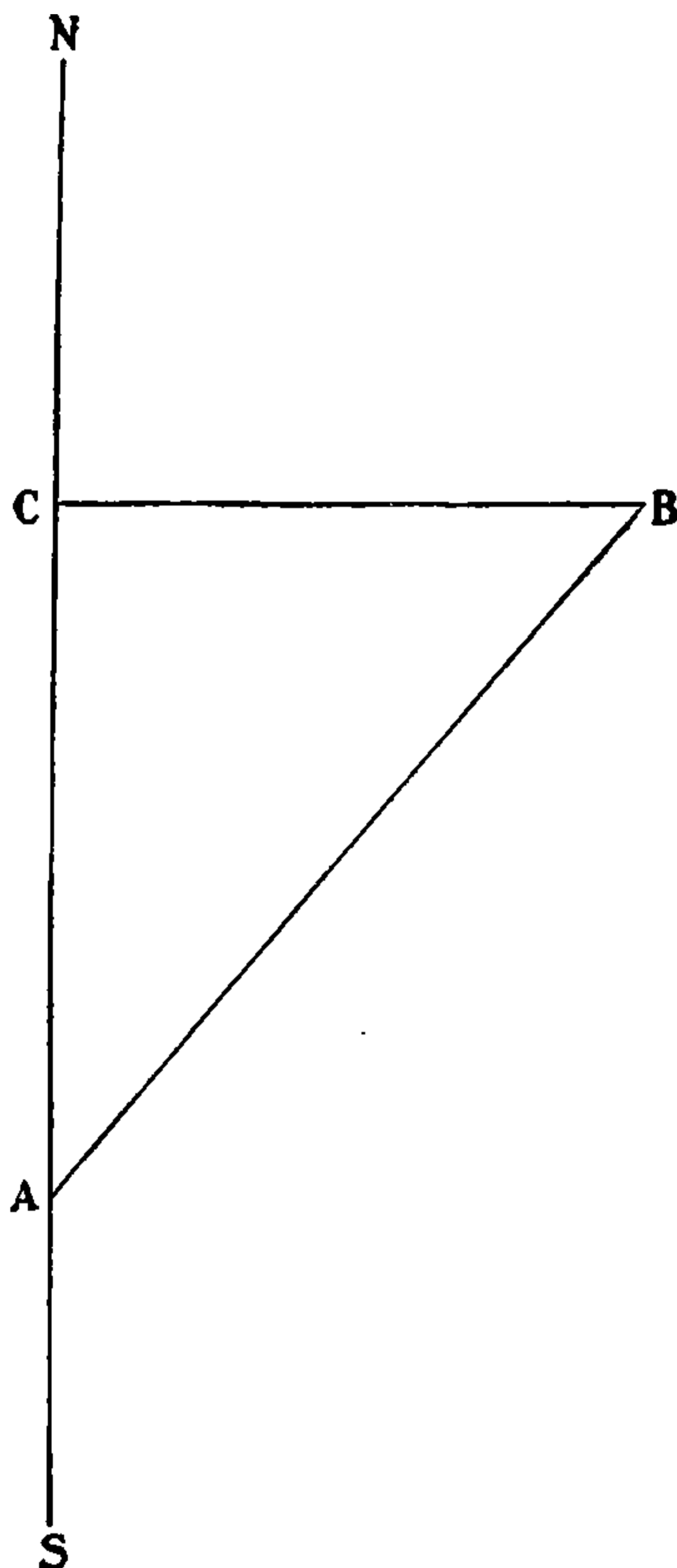

In the diagram $\text{Tan. Co.} = \frac{BC}{AC}$; if, therefore, we take BC to be Diff. Long., and AC to be Mer. Diff. Lat., we have formula (1). So, to use the Traverse Tables, find Mer. Diff. Lat. in the Diff. Lat. column, and Diff. Long.

in the Departure column, and take out the Course. With this Course and the Diff. Lat. you find the distance in the Distance column just as in Plane Sailing.

As a further instance of the way in which the Traverse Table can be used in a problem which has nothing to do with sailing. Suppose you want to ascertain your distance from a lighthouse, the height of which you know. Measure the angular height of the lighthouse above the sea level with a sextant. Enter the Traverse Table with this angle as a Course, and the height of the lighthouse, that is the Perpendicular, as a Departure. The Base of the triangle, that is your distance from the foot of the lighthouse, is in the Difference of Latitude column.

For example, let us suppose that you want to know your distance from a certain lighthouse which is 180 feet high from the lantern to the sea level. With your sextant measure the angle from the lantern of the lighthouse to the sea level, which we will suppose to be 4° . Look in the Traverse Table under 4° ; in the Departure column the largest number is only 41.9. Well, the best plan is to turn your feet into yards, that is 180 feet equal to 60 yards, and as this is still too big, take the half of it, namely, 30. Opposite 30 in the Departure column we find 428.9 in the Difference of Latitude column, and this multiplied by 2 gives us the distance we are in yards from the lighthouse, $428.9 \times 2 = 857.8$ yards.

CHAPTER VII

TIDES

Practical

FOR coasting, and indeed for many other purposes, it is essential that the mariner should be able to ascertain the time of High Water at any Port. Many excellent Tide Tables are in use, but none are better than those published by the Admiralty, and, as they will be furnished to you in the Board of Trade Examination, we will work out the problems with their help. A candidate for Second Mate's Certificate is required to find the Time of High Water at any Port.

To find the time of High Water at a given place, A.M. and P.M., on a given day of a given month.—Proceed thus:—If the given place, which for the future I will call the Port, for the sake of brevity, is a *Standard Port*, look for it among the Standard Ports on pages 2 to 97*a* of the Admiralty Tide Tables for 1898, and alongside the given day, which, for convenience sake, I will in future call the day, you will find the time of the A.M. and P.M. Tides—if there is an A.M. and a P.M. tide; if a blank (—) occurs it means that on that day there is no A.M. tide, or that there is no P.M. tide, as the case may be. The height of each tide is also given.

If the Port is not a Standard Port, then look for it among 'Tidal Constants' on pages 101–5 of the Tables. If you find it there you will also find in a line with it a Port of reference, which is a Standard Port; and



THIS PAGE IS LOCKED TO FREE MEMBERS

Purchase full membership to immediately unlock this page

DELVE INTO FANTASY, MAGIC, MYTHOLOGY & FOLKLORE

Forgotten Books'
Full Membership gives
access to 797,885 ancient
and modern, fiction and
non-fiction books.

Continue

*Fair usage policy applies

take that out as the A.M. tide at the Port, and look for a P.M. tide by applying the Constant to the A.M. tide of the next day at the Standard Port. All this is much more clearly seen in examples. Here are some:—

1. Find the Time of High Water A.M. and P.M. at Queenstown on August 18th, 1898.

Turn to the Index of the Admiralty Tide Tables on the page immediately after the Title Page, and you will find Queenstown; it is therefore a Standard Port, all the Ports mentioned on this page being Standard Ports. In the same line as Queenstown, under August, you will find 64*a*. This is the page on which you will find the A.M. and P.M. times of High Water at Queenstown for the month of August.

Turn to page 64*a* and you will find that the times of High Water at Queenstown on August 18th were 5.28 A.M. and 5.44 P.M.

These times are given in Mean Time at place, and if you want the time of High Water by your Chronometer or by a watch keeping Greenwich Time, you must, of course, apply the Longitude in Time.

Thus:

M. T. at Place	5 ^h 28 ^m A. M.	5 ^h 44 ^m P.M.
Longitude in Time W	33	33
	M. T. G. 6 1 A.M.	6 17 P.M.

That is to say, your clock will show 6 h. 1 m. A.M., and 6 h. 17 m. P.M., when it is High Water at Queenstown.

Should you be keeping Dublin Time on board you must add 8 minutes to Queenstown time, Queenstown being 8 minutes West of Dublin.

On looking through the Tide Tables for the Standard Ports you will notice that for Irish Ports these corrections in time are given for Dublin Time, while those for the English and Scotch Ports are given for Greenwich Time.

2. Find the Time of High Water A.M. and P.M. at Portishead on March 15th, 1898.

On page 24 you will see that the Time of High Water A.M. at Portishead is 11 h. 35 m., and that there is no P.M. Tide.

3. Find the Time of High Water A.M. and P.M. at Inverary on November 20th, 1898.

Inverary does not appear in the index, so it is not a Standard Port. Turn to pp. 101–5. On p. 103 you will find Inverary, and in the column nearest to it, under Time, the constant 0 h. 8 m. is given; and in the last column you will note that Greenock is the Standard Port.

Now turn to the index, and find out on what page to look for Greenock in the month of November. It is p. 87. On that page you will find that at that place on November 20th the times of High Water were at 4.14 A.M. and 4.55 P.M. Proceed thus :

High Water at Greenock	4 ^h 14 ^m A.M.	4 ^h 45 ^m P.M.
Constant for Inverary	— 8	— 8
High Water at Inverary	4 6 A.M.	4 37 P.M.

4. Find the Time of High Water A.M. and P.M. at Portland Breakwater on March 13th, 1898.

Portland Breakwater is not a Standard Port, and you will find, on referring to the Tidal Constant, that its Port of Reference is Portsmouth, and that its Constant of Time is—4 h. 40 m.

High Water at Portsmouth March 13th	2 ^h 23 ^m A.M.	2 ^h 44 ^m P.M.
Constant for Portland	— 4 40	— 4 40
High Water at Portland March 12th .	9 43 P.M.	10 4 A.M. on March 13

We have thus far only succeeded in finding the A.M. Tide of the 13th, and for a P.M. Tide we must look to the A.M. Tide of the next day.

High Water at Portsmouth on March 14th	3 ^h 6 ^m A.M.
Constant for Portland	— 4 40
High Water at Portland on March 13th	10 26 P.M.

In this case the Constant brings the A.M. Tide on the 13th into a P.M. Tide on the 12th. The P.M. Tide on the 13th becomes an A.M. Tide; and the A.M. Tide at Portsmouth of the 14th gives the P.M. Tide at Portland on the 13th. In all cases where a Constant for Time is given a Constant for Height is also given, and the height of a Tide is found in the same way as the time of that Tide.

You may want to find the time of High Water at some Port which has not got a Constant on any Standard Port in the Admiralty Tables. You can do so if the time of High Water at Full and Change is given. The time of High Water at Full and Change is called the 'Establishment,' and the Establishment is given in the Admiralty Tide Table, in the Nautical Almanac, and in Table LVII. for a great number of Ports all over the world. Proceed by one or other of the two following methods:

From page IV of the Nautical Almanac take out the time of the Moon's Meridian Passage on the given day. It is given in Mean Time. Find the Longitude of the Port. Take out the Moon's Semi-Diameter from page III. of the month in the Nautical Almanac. Take out the Equation of Time from page II. of the Nautical Almanac. Then find the Apparent Time of the Moon's Meridian Passage or Transit at the Port in the following way:

Owing to the Moon's proper motion the Time of Transit is in East Longitude, earlier, and in West Longitude later, than the Time of Transit at Greenwich; a correction for Longitude has therefore to be applied to the Greenwich Time of Transit. If you are in *East* Longitude find the difference between the Times of the Moon's Transit at Greenwich on the day and on the day *before*. If you are in *West* Longitude find the difference between the Times of Transit on the day and on the day *after*. Enter



THIS PAGE IS LOCKED TO FREE MEMBERS

Purchase full membership to immediately unlock this page

SAVE \$3,999,994

Did you know we sell
paperback books too?

To buy our entire catalog
in paperback would cost
over \$4,000,000

Access it all now for
\$8.99/month

*Fair usage policy applies

Continue

1. Find the Times of High Water A.M. and P.M. at Port Natal on May 4th, 1898.

Port Natal High Water Full and Change	. 4 ^h 30 ^m
Moon's Transit May 4th 10 ^h 38.3 ^m
" " May 3rd 9 46.9
Difference of Transits 51.4

Moon's Semi-Diameter 16' 11'' Equation of Time 3^m 22^s + on Mean Time

Moon's Transit on 4th 10 ^h 38.3 ^m
Correction for { Long. 31° E Diff. Trans. 51.4 ^m } - 4
Mean Time of Moon's Transit 10 34.3
Equation of Time + 3.4
Apparent Time of Transit 10 37.7
Mean Time of Moon's Transit 10 ^h 34.3 ^m
Correction for { Moon's S.-D. 16' 11'' A. T. of Trans. 10 ^h 37 ^m } + 26
	. 11 0.3
High Water, Full and Change at Port Natal	. 4 30
High Water Port Natal May 4th 15 30.3
	. 12 24
High Water Port Natal May 4th 3 6 P.M.
	. 24 ^m
" " " " " " " " " " " "	. 2 42 A.M.

And here it is worked out the other way—let us take Brest for the Standard Port :

Brest High Water Full and Change 3 ^h 47 ^m
Port Natal " " " " 4 30
Constant + 0 43

Long. Brest 4° 29' W
" P. Natal 31° 0' E
Diff. Long. 35° 29'
Moon's Transit 3rd 9 ^h 47 ^m
" " 4th 10 38
Diff. Transit 0 51

Brest High Water 1 ^h 53 ^m A.M.	. 2 ^h 14 ^m P.M.
Constant + 43	. + 43
	. 2 36	. 2 57
Correction for { Diff. Long. 35½ E° Diff. Trans. 0 ^h 51 ^m }	. - 5	. - 5
Time of High Water at Port Natal 2 31 A.M.	. 2 52 P.M.

2. Find the Times of High Water A.M. and P.M. at Nelson, New Zealand, on October 12th, 1898.

Brest H. W., F. and C.	. 3 ^h 47 ^m	Brest Longitude	. 4° 29' W
Nelson „ „ „	. 9 50	Nelson „	. 173° 17' E
Constant .	+ 6 3	Diff. Long. .	177° 46' E

Moon's Transit, Oct. 11th	. . . 8 ^h 35 ^m
„ „ Oct. 12th	. . . 9 18
Diff. Trans.	. . . 0 43

Brest High Water, Oct. 12th	. 1 ^h 19 ^m A.M.	1 ^h 38 ^m P.M.
Constant .	. + 6 3	+ 6 3
	<u>7 22</u>	<u>7 41</u>
Correction for { Diff. Long. 178° E	} - 21	- 21
{ Diff. Trans. 43 ^m		
High Water, Nelson, Oct. 12th	7 1 A.M.	7 20 P.M.

3. Find the Times of High Water A.M. and P.M. at Port Augusta, British Columbia, on December 28th, 1898.

Brest H. W. F. and C.	. 3 ^h 47 ^m	Brest Long.	4° 29' W
Port Augusta H. W. F. and C.	5 00	Port Augusta „	123° 26.7' W
Constant .	. + 1 13	Diff. Long. .	118° 57.7' W

Moon's Transit, Dec. 28th	. . . 0 ^h 2 ^m
„ „ Dec. 29th	. . . 0 50
Diff. Trans.	. . . 0 48

Brest High Water, Dec. 28th	. 3 ^h 52 ^m A.M.	4 ^h 10 ^m P.M.
Constant .	. + 1 13	+ 1 13
	<u>5 5</u>	<u>5 23</u>
Correction for { Diff. Long. 119° W,	} + 16	+ 16
{ Diff. Trans. 48 ^m		
H. W. at Port Augusta, Dec. 28th	5 21 A.M.	5 39 P.M.

If the height of tide is required in these cases, take the Difference between the height at the place and at Brest at H. W. Full and Change as a Constant. Apply the Constant to the height at Brest for the tide in question.

Soundings

You must be able to ascertain the amount of correction to be applied to the depth of water obtained by soundings, conditional upon the state of the tide when you took a cast of the lead, for it must be remembered that soundings are given on the chart for low water ordinary springs, and that in many places the rise and fall of tide is so great as to make it very desirable to ascertain what correction to make to the depths upon the chart.

The correction is always to be deducted from soundings, except in the very rare case of the water being lower at the time when soundings were taken than at low water ordinary springs.

You proceed thus : ascertain, 1st, the time of high water at the Port you are nearest to; 2nd, the height to which that Tide rises above low water ordinary springs; 3rd, the Mean Level of the sea, or, as it is called, the 'Half Mean Spring Range,' which is given in the Admiralty Tide Tables under the columns of times of tides for the Standard Ports; 4th, the difference between sea-level at the time the cast was taken, and the mean sea-level.

Find the time of high water by the method already explained under 'Tides,' pages 170-177, and take the difference between this time and the time at which you took a cast of the lead, so as to get the interval between time of high water and time of sounding. Find the height of Tide in the manner already explained under 'Tides' in the same pages. Take out the Half Mean Spring Range from the Tide Tables, or find it by halving the rise of tide at Full and Change.

Then from the height of Tide subtract the Half Mean



THIS PAGE IS LOCKED TO FREE MEMBERS

Purchase full membership to immediately unlock this page

DELVE INTO FANTASY, MAGIC, MYTHOLOGY & FOLKLORE

Forgotten Books'
Full Membership gives
access to 797,885 ancient
and modern, fiction and
non-fiction books.

Continue

*Fair usage policy applies

meaning of some of the expressions used in connection with the correction for soundings.

FIG. 28

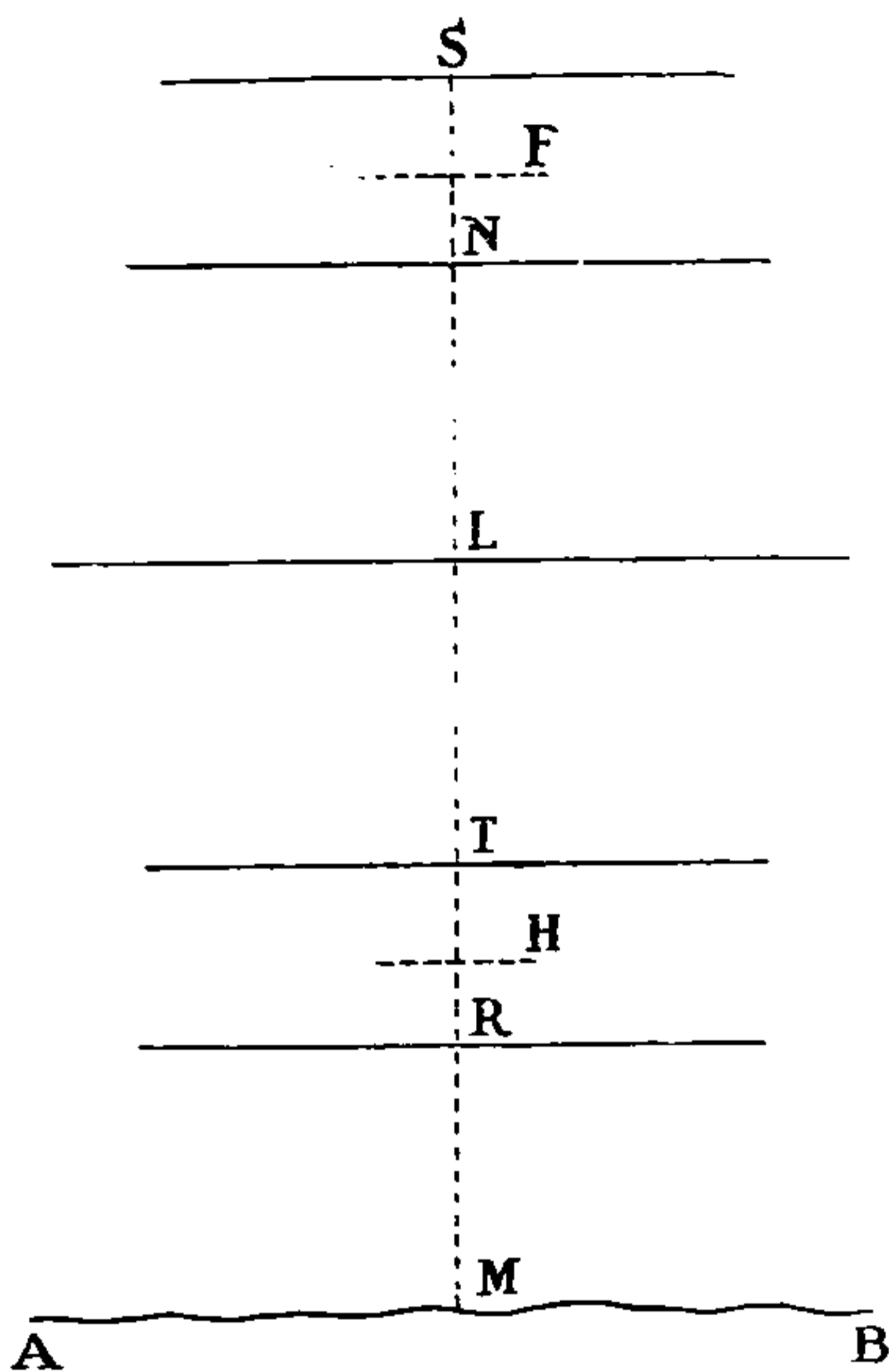

Let AB be a portion of the bottom of the sea; R the level of the surface of the sea at low water ordinary springs; S its level at high water ordinary springs; then SR is the Spring Range, or, as it is called, the Mean Spring Range—that is the average change of level between high and low water at ordinary springs. Half-way between these two points, that is at L , is the Mean Level of the sea, because if at any tide the sea rises to a distance LS above that point, it will fall to an equal distance below it, that is LR .

At Neap Tides the water rises to N and falls to T .

The line marked L indicates the mean level of the sea; the point R represents low water ordinary springs, and LR is the Half Mean Spring Range.

The soundings on an Admiralty chart are given as taken at low water ordinary springs, so that the sounding on the chart in this case would be $R M$. Now suppose you had taken your cast at high water at Full and Change of the Moon, that is at Spring Tides, you would have to deduct the distance $S R$, that is the whole of the Spring Range, from your cast before comparing it with the chart. Three hours after high water the level of the sea would be at L , and you have in that case only to deduct $L R$, the Half Mean Spring Range.

At Springs the rise of the tide is $R S$, at Neaps it is $T N$. The height above low water ordinary springs of any given tide on any day must lie between $R N$ and $R S$, and these are the heights tabulated for the Standard Ports.

Suppose on a certain day the tide rises to F , the height of that tide is $R F$. It will fall to H at low water, $L F$ being equal to $L H$. From $R F$, which is the position of that particular tide, you deduct $R L$, the Half Mean Spring Range, and you get $L F$, or $L H$; this is the position to which that tide rises above and falls below the mean level of the sea at L . With this and the time of sounding we find by the aid of Table B, or by that of the Traverse Table, what proportion of $L F$ is to be added to or deducted from $L R$, the Half Mean Spring Range, in order to find the position of the level of the sea at the moment of sounding above its level at low water ordinary springs, and this height above must be deducted from the sounding taken. As I have already mentioned, when extraordinary Spring Tides occur, and the level of the sea rises above and sinks below the level of ordinary Spring Tides, your sounding might be taken with the level of the sea between R and M , in which case the correction would have to be added.

Here are some examples :

1. On November 9th, 1898, being off Portishead at 4 A.M., M. T. S., took a cast of the lead. Required the correction to be applied to soundings before comparing it with the chart.

Portishead is a Standard Port. On page 88 of the Admiralty Tide Tables you will find that the time of High Water nearest to the time the cast was taken is 2 h. 25 m. A.M. on November 9th, 1898.

High Water at Portishead	2 ^h 25 ^m A.M.
Time of Sounding	4 00 A.M.
Interval between H. W. and Time of Sounding	1 35
Height of that Tide	ft. 32 in. 1
Half Mean Spring Range	21 0
Height above Mean Level of Sea	11 1

Enter Table B with 1 h. 35 m. at top (1 h. 30 m. is the nearest, and it is near enough in actual practice) and 11 ft. 1 in. at the side (11 ft. is the nearest, and is good enough in practice) and you will find the correction to be 7 ft. 9 in., and it is to be added to the Half Mean Spring Range. Therefore we have :

Half Mean Spring Range	ft. 21 in. 0
Correction	+ 7 9
Correction to Soundings to be subtracted	28 9

Now to work the same examples by the Traverse Table.

Time of Soundings from H. W	1 ^h 35 ^m	Height	ft. 11 in. 1 or 11.1
	<u>2</u>		very nearly.
Doubled Time or 'Difference'	3 10	Turned into arc =	47 $\frac{1}{2}$ °

Enter the Traverse Table with 47° as a Course and 11.1 as a Distance, and in the Difference of Latitude column you will find 7.5 as the correction ; 7.5 ft. = 7 ft. 6 in., which very nearly corresponds with the result obtained by the other method.



THIS PAGE IS LOCKED TO FREE MEMBERS

Purchase full membership to immediately unlock this page

SAVE \$3,999,994

Did you know we sell
paperback books too?

To buy our entire catalog
in paperback would cost
over \$4,000,000

Access it all now for
\$8.99/month

*Fair usage policy applies

Continue

The height above the mean level of the sea is 6 ft. 5½ in., but ignore the odd ½ in., and treat the height as if it were 6 ft. 6 in.; take out from Table B the correction for the mean between 6 ft. and 7 ft. at 3 h. 30 m. and 4 h. intervals from High Water, and then find by proportion the exact amount of correction for 3 h. 37 m.

At 3 h. 30 m. time from High Water, the correction for the mean between 6 ft. and 7 ft. is 1 ft. 8½ in. At 4 h. the correction for the same height is 3 ft. 9 in.

At 3 ^h 30 ^m the correction to subtract is	ft. in.
	1 8½
„ 4 00 „ „ „ „ „	3 9
Between 3 ^h 30 ^m and 4 ^h the Tide fell	2 0½

What will it have fallen in 7 minutes ?

We have the proportion sum :

$$\text{As } 30 \text{ m.} : 7 \text{ m.} :: 2 \text{ ft. } 0\frac{1}{2} \text{ in.} : x$$

6 inches is the answer nearly enough.

At 3 ^h 30 ^m the correction was	ft. in.
	1 8½
In 7 minutes it fell	6

At 3 ^h 37 ^m the correction is	2 2½
---	------

(to be subtracted from the Half Mean Spring Range).

Half Mean Spring Range	ft. in.
	8 10½
By Tables correction for 3 ^h 37 ^m and 6½ ft.	2 2½
Correction to be subtracted from Sounding	6 8

By the Traverse Table :

Interval	. . .	3 ^h 37 ^m	Height above Mean Level of Sea	ft. in. in.
				6 5½ = 77½
		2		
Double Interval or Diff.		7 14		
		12 00		
Difference		. 4 46		in time or 71½° in arc.

With 71½° as a Course, and 77½ as a Distance in the Traverse Table, you will find 24 (very nearly) in the Difference of Latitude column as the correction to be applied to the Half Mean Spring Range. Half Mean Spring Range 8 ft. 10½ in. – 24 in. correction = 6 ft. 10½ in., to be subtracted from soundings; practically the same as the correction found by Table B.

In dealing with a foreign Port, the time of High Water must be found by the method explained in Tides on page 174 ; a Constant for Height must be ascertained by taking the difference between the Spring Range at the Port in question, and that of some Standard Port, generally Brest. The Half Mean Spring Range is found as in the previous example, and then you have all the requisite data. Here is an example :

3. On September 27th, at 11.30 P.M., being off Haute Isle, Bay of Fundy, took a cast of the lead. Required the correction to be applied to the sounding before comparing it with the chart.

In the last Table in the Admiralty Tide Tables, on page 226, you will find the following :

		High Water at Full and Change		Spring Ris	
				ft.	in.
Page 226 Haute Isle	. 11 ^h 21 ^m	Haute Isle	. . .	33	0
„ 215 Brest	. . 3 47	Brest	. . .	19	6
Constant for Time	. + 7 34	Constant for Height	. +	13	6
Long. of Brest	. . 4½° W	Moon's Transit Sept. 27th	. 10 ^h 7 ^m		
„ Haute Isle	. 65° W	„ „ „ 28th	. 10 55		
Diff. of Long.	. . 60½° W	Diff. of Transit	. . .	0	48

High Water at Brest on Sept. 27th	. . .	1 ^h 49 ^m P.M.
Constant for Haute Isle	. . . +	7 34
		9 23

Correction for { Diff. Long. 60° W } { Diff. Trans. 48 ^m }	. . .	+ 8
--	-------	-----

High Water at Haute Isle	. . .	9 31 P.M.
Time of Sounding	. . .	11 30 P.M.
Interval between H. W. and Time of Sounding		1 59

		ft.	in.
Height of that Tide at Brest	. . .	17	6
Constant for Haute Isle	. . . +	13	6
Height of that Tide at Haute Isle	. . .	31	0
Half Mean Spring Range 33 ÷ 2	. . . =	16	6
Height of that Tide above the Mean Level of the Sea		14	6

		ft.	in.	ft.	in.
Table B. Corr. for 2 ^h (the nearest to 1 ^h 59 ^m) and	14 6	+	7 3		
Half Mean Spring Range	. . .		16 6		
Correction to be deducted from Sounding	. . .		23 9		

Using Traverse Table instead of Table B :

Interval	1 ^h 59 ^m
		2
Double Interval	3 58 in time = 59½° in arc.

Height of that Tide above the Mean Level of Sea 14 ft. 6 in. = 14·5 ft.

With 60° as a Course, and 14·5 as a Distance, you will find 7·36 or 7 ft. 4 in. in the Diff. of Lat. column, which is within an inch of the correction to be applied to the Half Mean Spring Range as found by Table B.

4. On May 7th, 1898, at 6 P.M., being off Liverpool, I took a cast of the lead.

By Admiralty Tables :

Liverpool, Time of High Water	0 ^h 1 ^m A.M. May 8th
" " " Sounding	6 0 P.M. May 7th
Interval between High Water and Time of Sounding	6 1	

Height of that Tide	ft. 27	in. 11
Half Mean Spring Range	13	9
Height of that Tide above the Mean Level of the Sea		14	2

Time from Sounding, 6 hours

Height above Mean Level of Sea	ft. 14	in. 2
Half Mean Spring Range	13	9
Correction to add to Soundings	0	5

By Traverse Table :

Interval	6 ^h 1 ^m
		2
Double Interval	12 2	
		12 0
Difference	0 2	

Height of that Tide above the Mean Level of the Sea	ft. 14	in. 2
---	--------	-------

If the Course is 0° your ship is sailing on a Meridian, and the Distance is the same thing as the Difference of Latitude, and therefore in the case before you the correction is 14 ft. 2 in. to be subtracted from the Half Mean Spring Range.

The Traverse Tables give more accurate results than the B Tables, for the latter often require averaging and



THIS PAGE IS LOCKED TO FREE MEMBERS

Purchase full membership to immediately unlock this page

DELVE INTO FANTASY, MAGIC, MYTHOLOGY & FOLKLORE

Forgotten Books'
Full Membership gives
access to 797,885 ancient
and modern, fiction and
non-fiction books.

Continue

*Fair usage policy applies

force than a portion at the centre *C*, and a portion at *B* is pulled with a less force than a portion at *C*. But the solid portion of the Globe moves bodily, as no part of it can yield to the Moon's attraction without the rest. With the fluid portion it is different; at *A*, the fluid yields to the excess of the Moon's attraction and bulges out towards her. At *B* the fluid, not being so much affected by the Moon's attraction as is the solid, is, as it were, left behind, and bulges out. Consequently there is a rising of the water on the side of the Earth under the Moon, and also a rising of the water on the opposite side.

FIG. 29

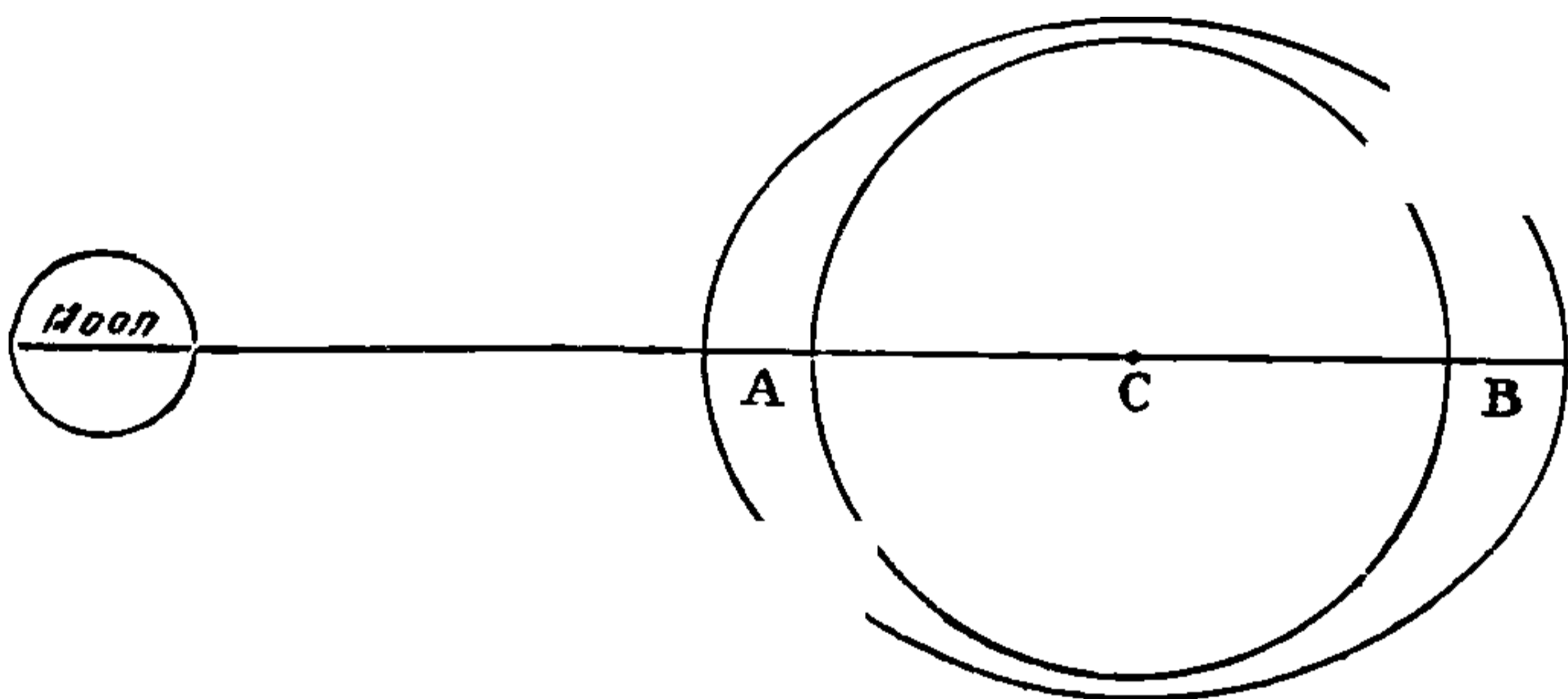

I speak chiefly of the Moon, because her attractive power is much greater than that of the Sun in this regard, being in the ratio of about $2\frac{1}{4}$ to 1, and she is therefore the chief factor in causing tides. The Sun, however, has an effect, and when it is in conjunction and pulls in the same direction as the Moon, that is to say at New Moon, the tidal undulation is increased by the joint action of both Bodies, and we have Spring Tides. Also when the Sun is in opposition, that is at Full Moon, and pulls in the opposite direction, the same effect is produced, because its action causes the water to be raised both under it and on the opposite side of the Earth—that is, at exactly the

places where the Moon's action also causes the water to be raised—and Spring Tides occur. When, on the other hand, the Sun's attraction acts at right angles to that of the Moon, as is the case at the time of the first and third quarters, the position of the Bodies tends to neutralise the effects of their attraction; the tides do not rise high, and we have Neap Tides.

The diagrams here appended show the effect of the attraction of the Sun and Moon at New and Full Moon, and at the first and third quarters.

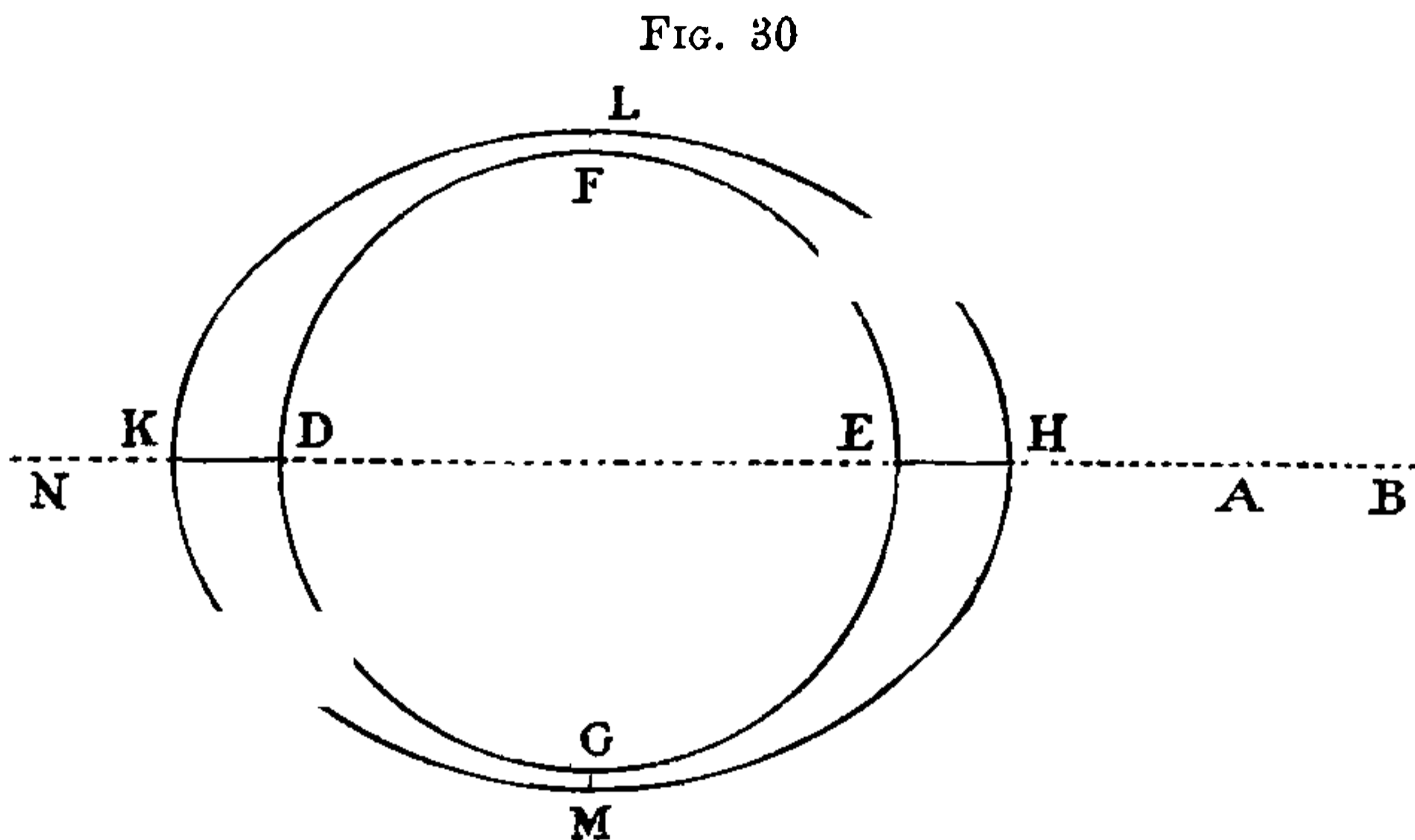

In diagram No. 30 let F E G D represent the Earth, and H M K L its watery envelope; A the position of the Moon, and B that of the Sun. When the Sun and Moon are in conjunction—that is, in a line on the same side of the Earth—their gravitation pulls together; the height of the water at E H and K D is at its maximum, while at L F and G M it is at its minimum, and we have Spring Tides at New Moon. Also when the Moon is in opposition at N her attraction raises the water at D K and E H, where the Sun's attraction also raises the water, and we have Spring Tides at Full Moon.

Diagram No. 31 shows a different state of affairs. The Sun being at B and the Moon at A, their gravitations act at right angles to each other, and tend to balance each other; in consequence of this, the tide neither rises as high at E H and K D, nor falls so low at L F and G M as it does in the former instance, and we have Neap Tides.

FIG. 31

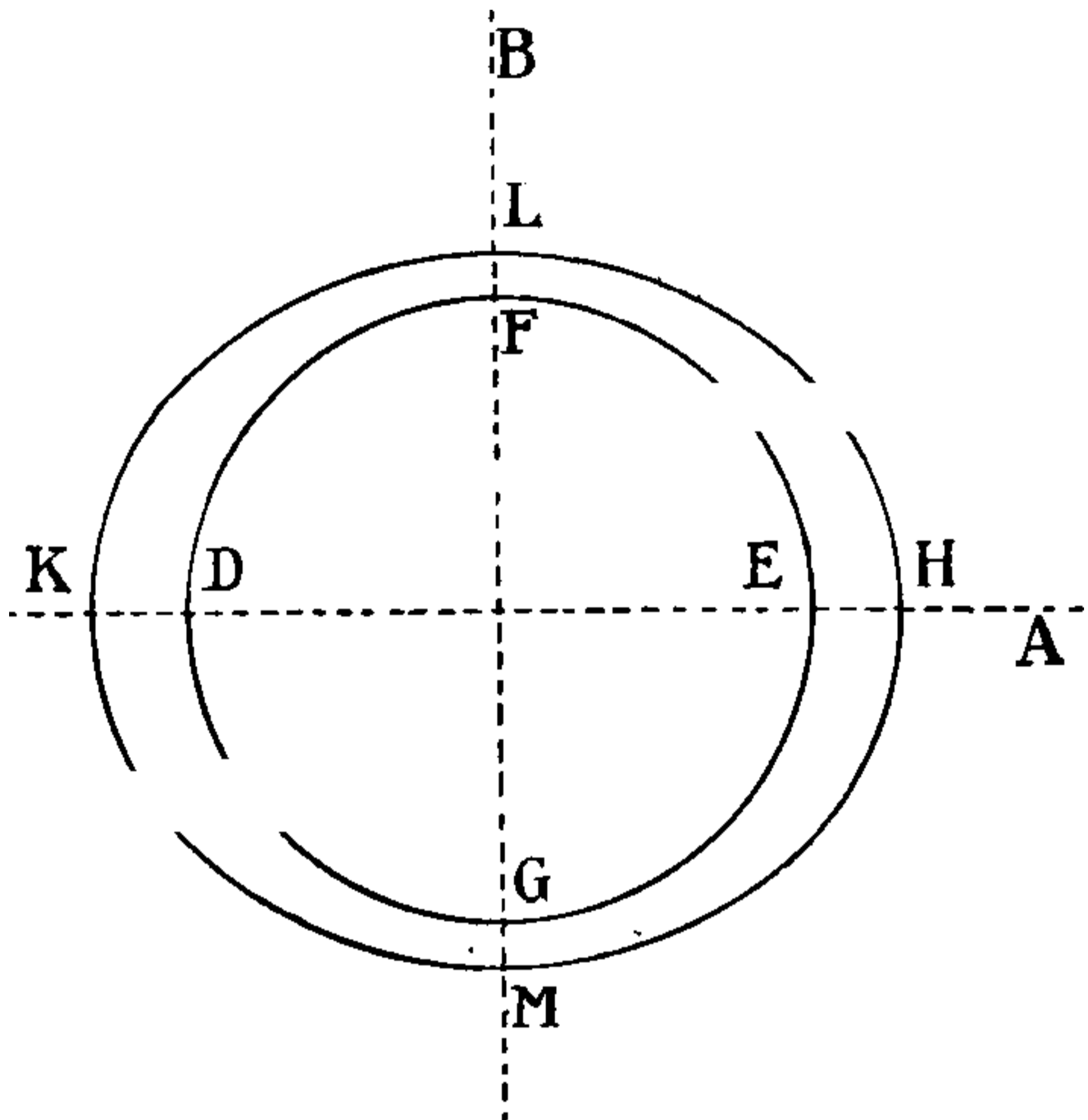

Tides and Tidal Streams.—The Moon, owing to the Earth's rotation on her axis combined with the Moon's own motion, appears to revolve round the Earth in about 24 hours 48 minutes, thereby causing two tidal waves to sweep round beneath her, so that we have two high tides and two low tides in that time. These tidal waves are simply a rising and falling of the water, for little or no horizontal motion is imparted to it until, owing to the shape of the land, or the decrease in the depth of the water, this perpendicular movement is converted into a horizontal one.

Imagine yourself to be standing on the pier-head on a day when there is no wind, and the sea is glassy in its



THIS PAGE IS LOCKED TO FREE MEMBERS

Purchase full membership to immediately unlock this page

SAVE \$3,999,994

Did you know we sell
paperback books too?

To buy our entire catalog
in paperback would cost
over \$4,000,000

Access it all now for
\$8.99/month

*Fair usage policy applies

Continue

Oceans, where land does not obstruct them, they act quite irregularly everywhere else.

The tidal wave which sweeps round the Cape of Good Hope from East to West spreads in every direction, and a portion travels up the South Atlantic Ocean, proceeds onward up the North Atlantic Ocean, and finally arrives on our coast from the South-westward. That is to say the tidal wave, which, if there were no land to intervene, would always travel from East to West, reaches us from quite a different direction.

Let us consider for a moment the effect produced by this tidal wave approaching our coast from the Atlantic. At about 4 P.M. upon the day when the Moon is on the Meridian of Greenwich at about Noon, or as it is called technically at Full and Change of the Moon, the crest of the great tidal wave stretches from the West coast of France to the North-westward, curving to the Northward, and trending parallel to, and at a short distance from, the West coast of Ireland. It is quite clear that a line drawn along the crest of this wave will be the line of high water. Therefore, at all places and on any part of the sea traversed by this line, it will be high water at the same time. This line is commonly called the Co-tidal Line. At 5 P.M. on the same day this tidal wave has reached the South and West coasts of Ireland, and it curves up the Bristol Channel till within a few miles of St. Bride's Head, when it recurves South to the Scilly Islands and Land's End, and continues along the South coast of England as far as Start Point, when, after bellying out a little to the Eastward up the English Channel, it trends Southerly to the coast of France.

The tidal undulation would on the Equator, if there were no obstruction by land or from any other cause, travel at the rate of about a thousand miles an hour, but

in our waters it advances only at the rate of from twenty to fifty miles an hour. It is divided by the coast of Ireland into two portions ; the Northern portion is again divided by the coast of Scotland into two parts, one of which goes to the Northward round the Northern extremity of Scotland, while the other finds its way through the North Channel into the Irish Sea. The Southern portion passes the South coast of Ireland, and divides itself into three parts ; one part goes up the Irish Channel and meets the tidal wave from the North in the centre of the Irish Sea ; another part swells the water in the Bristol Channel ; and the third part gives high water in succession to the ports of the English Channel. This latter portion at length meets in the Straits of Dover with the other tidal wave which has come round the North coast of Scotland, and made its way to the Southward along the East coasts of Scotland and England.

A glance at the position of affairs at 11 P.M. on the same day will be interesting. Two tidal waves have travelled up the Irish Sea, one coming from the Southward and the other from the Northward. A tidal wave has gone up the Bristol Channel, another up the English Channel, and another has swept round the Northern extremity of Scotland and has run down the East coasts of Scotland and England. The tidal waves have met in the centre of the Irish Sea, giving high water from Dublin to Carlingford Bay on the coast of Ireland, and from Liverpool Bay on the coast of England to the South of Scotland. It is also high water in the Straits of Dover, and at the mouth of the Thames, where the English Channel and North Sea tidal waves have met. And another tidal wave causes it to be high water about the North-eastern coast of Scotland. At the same time it is low water on the South-west and South coasts of

Ireland, on the South coast of England from the Scilly Islands, and Land's End to the Start, and on the East coast of England about Flamborough Head.

So much for the tidal *waves* at Full and Change ; now let us turn our attention to the tidal *streams*. The Northern tidal wave enters the Irish Channel about 7 P.M., that from the South coming in one hour earlier. The tidal streams, however, which accompany these waves, have no such difference in their time of flow and ebb in any part of the Irish Sea, but are found to commence and cease simultaneously. The current sets to the Northward in its Southern portion during the flow of the tide, and the current runs to Southward in its Northern half during the same period. The exact reverse of this occurs during the ebb of the tide. A little to the Westward of the Isle of Man there is an area of between fifteen and twenty miles where no tidal stream manifests itself.

In the Irish Sea tides are referred to Liverpool, because it is a Standard Port ; but as the times of slack water in the Irish Sea correspond with the times of high and low water at Fleetwood and Morecambe Bay, which occur twelve minutes earlier than at Liverpool, it is simpler in considering the tides to refer to Fleetwood.

For nearly six hours after low water at Fleetwood and Morecambe Bay the tidal streams are pouring into the Irish Sea, both from the Northward and Southward, and then for nearly six hours afterwards they are rushing outwards. Their velocity is about two-and-a-half knots an hour on an ordinary spring tide, except when the narrowing of the Channel, as at the Mull of Cantire, or the shoaling of the water in other parts, causes the speed to vary.

In the English Channel, and in the North Sea as far



THIS PAGE IS LOCKED TO FREE MEMBERS

Purchase full membership to immediately unlock this page

DELVE INTO FANTASY, MAGIC, MYTHOLOGY & FOLKLORE

Forgotten Books'
Full Membership gives
access to 797,885 ancient
and modern, fiction and
non-fiction books.

Continue

*Fair usage policy applies

about three-quarters of an hour; that the actual time during which the tidal streams run either way is about five hours and forty minutes, and that their greatest velocity is nearly always attained about three hours after slack water. As the speed gradually increases to its maximum, and as gradually decreases to its minimum, it is possible to roughly estimate its velocity at any given time, but it is advisable to ensure accuracy by consulting the Admiralty Tidal Charts.

The tidal wave in the Atlantic, as we have already seen, strikes the South-west coast of Ireland, and divides into three portions, one running up the English Channel to the Eastward; another running along the West coast of Ireland and Scotland to the Northward, and thence round by the Shetlands and Orkneys to the Southward, along the East coast of England; and the third entering the Irish Sea by way of St. George's Channel. The general direction of the tidal stream during the flood is to the Eastward in the English Channel, to the Southward in the Northern portion, and to the Northward in the Southern portion of the Irish Sea, to the Northward along the West coast of Ireland and Scotland, to the Eastward off the Shetlands and Orkneys, and to the Southward along the East coast of England.

In order to explain more easily the direction of the tidal streams in the English Channel, it is convenient to divide it into four imaginary parts, the first part lying to the Westward of a line joining the Land's End and Ushant, the second between this line and a line joining the Start and Casquets, the third between this line and a line drawn from Beachy Head to Point d'Ailly, the fourth from that line to a line joining the North Foreland and Dunkerque.

In the first of these divisions the tides run in all

directions right round the compass during each twelve hours.

In the second division the tidal streams are irregular, as the main Channel tide is interfered with by currents flowing into and out of the Gulf of St. Malo, and also by variable currents to the Westward of the Land's End.

While the water is falling at Dover, the tidal stream sets directly into the Gulf of St. Malo on the French side of the Channel, curving round Cape La Hogue, and setting South-westerly to South-easterly on either side of the bay. The reverse takes place when the water is rising.

In the third division, or 'Channel proper,' the tides are fairly regular, flowing to the Eastward while the water is rising at Dover, and to the Westward when it is falling at that port. The tide is slack over all this section at the same time.

The tides in the last division, known as the 'Straits of Dover' tides, demand most careful consideration. While the tide is rising at Dover, the Channel stream, and the streams in the North Sea, to the Southward of a line joining the Wash and the Texel, meet; but their line of meeting is not stationary, it shifts continually between Beachy Head and the North Foreland. When the water is falling at Dover, the Channel and North Sea streams separate, but the line of separation also shifts continually between Beachy Head and the North Foreland.

When it is high water at Dover, it is slack water at Beachy Head and Point d'Ailly and to the Westward. Eastward of the line between Beachy Head and Point d'Ailly the stream runs Easterly as far as the North Foreland, where it is also slack water.

One hour after high water at Dover the stream is going to the Westward in the Channel from the 'Royal

Sovereign' lightship Westward ; but to the Eastward of the lightship the current sets Easterly.

Two hours after high water at Dover, the line of separation of the streams is between Hastings and Treport, that is to say, West of this line the water runs to the Westward and East of the line it runs to the Eastward.

Three hours after high water at Dover, the line of separation is between Hastings or Rye on the English coast and Cayeaux on the French coast.

Four hours after high water at Dover the line has shifted to a line between Folkestone and Cape Grisnez ; five hours after high water at Dover to a line between the South Foreland and Calais, and six hours after high water at Dover to a line between the North Foreland and Dunkerque.

When it is low water at Dover the line of separation is from Ramsgate to the Texel, and the stream is very nearly slack. One hour after low water at Dover the stream is Easterly West of a line between Beachy Head and Point d'Ailly. Two hours afterwards it commences to run to the Eastward off Hastings, and three hours afterwards off Rye and Cayeaux, four hours afterwards off Dungeness and Cape Grisnez, four and a half hours afterwards off Dover and Gravelines, five hours afterwards off the South Foreland and Dunkerque, six hours afterwards off the North Foreland and a little to the Westward of Dunkerque.

You will observe that the direction of the stream is not always indicated by the time of high water. At Dover, for instance, the tide commences to flow to the Eastward one and a half hours before high water, and continues to run in that direction until four and a half hours after high water. As has already been stated, it is slack water in the Channel to the Westward of Dover



THIS PAGE IS LOCKED TO FREE MEMBERS

Purchase full membership to immediately unlock this page

SAVE \$3,999,994

Did you know we sell
paperback books too?

To buy our entire catalog
in paperback would cost
over \$4,000,000

Access it all now for
\$8.99/month

*Fair usage policy applies

Continue

versa—in other words the tide takes about 6 hours to traverse that distance; that the rise of tide at Dover at Springs is $18\frac{3}{4}$ ft., and that it is at $16\frac{1}{4}$ ft. at Penzance; that at Portland Breakwater there is only a rise of $6\frac{3}{4}$ ft., while at Poole it is only $6\frac{1}{2}$ ft. In fact, the water in the English Channel seems to see-saw between Dover and Penzance, where the rise and fall of the tide are greatest, and midway between these two places there is very little rise and fall. This fact accounts for the rapid tidal streams in the Channel, or the rapidity of the streams accounts for the fact—whichever way you like to take it. It is quite evident that when the tide at Penzance is, as we have said, $16\frac{1}{4}$ ft. above its lowest level, and in the succeeding 6 hrs. falls that $16\frac{1}{4}$ ft., while at the same time the water at Dover is rising $18\frac{3}{4}$ ft., there must be a very large body of water shifted from one end of the Channel to the other.

In the North Sea the flood tide is still making at the mouth of the Thames when it is high water at Dover. From the Thames to the parallel of 54° North it is slack water. From 54° to 56° North there is a slight Northerly set, and from 57° to 59° North, a drift to the Southward exists.

At one hour after high water at Dover, the state of affairs is as follows: At the mouth of the Thames slack water; from the mouth of the Thames to 54° North a Northerly stream of from 1 to 2 knots; on the parallels of 55° to 56° the water is more or less slack; but to the Northward of this there is a slight Southerly set.

Two hours after high water at Dover it is ebb tide at the mouth of the Thames, and the other streams remain unaltered.

Three hours after high water at Dover, tide still ebbing at the mouth of the Thames. A Northerly cur-

rent as far as 53° North, and Westerly and Southerly currents from 54° to 57° North.

Four hours after high water at Dover, tide continues to ebb at the mouth of the Thames. Stream sets to the Northward as far as 54° North. To the Northward of this currents are irregular, and we have a Southerly current close in along the coast from St. Abb's Head nearly to the Wash, and a Northerly current along the coast of Scotland from the Firth of Forth to the Orkneys. Six hours after high water tide still ebbing at the mouth of the Thames, slack water off Harwich, a Northerly stream sets as far as the 54th parallel, except close in to the coast of France and Belgium, where it runs to the South-westward; the Southerly stream close in to the East coast of England now comes down as far as the Wash.

Five hours before high water at Dover, we have slack tide at the mouth of the Thames. There is a Southerly stream along the coast of England, from the River Tyne to the Straits of Dover. To the Northward of 54° N the stream is Easterly, and further to the Northward it is Northerly.

Four hours before high water at Dover the flood begins to make at the mouth of the Thames. To the Southward of 53° North there is a Southerly set, but close in to the coast of England and Scotland a stream sets to the Northward, and in the remainder of the North Sea the streams are irregular.

Three hours before high water at Dover the flood is still running rapidly at the mouth of the Thames, and the general condition of affairs is much the same as at four hours, except that the Northerly stream close to the coast now extends South to the Wash. A North-easterly stream, however, sets close in along the French coast.

Two hours before high water at Dover the flood tide is still running rapidly at the mouth of the Thames, and the state of affairs is much the same as that which existed at three hours, as previously described. One hour before high water at Dover the flood is still running at the mouth of the Thames, and the streams in the North Sea are very much as they were at two hours.

In the Irish Sea the tidal streams begin to flow through the North and South ends at one hour after low water at Morecambe Bay. The current from the South runs up until it passes Holyhead, when the greater portion of it sweeps round to the Eastward, passing to the Southward of the Isle of Man, and there meeting with the current from the Northward, they together flow with considerable velocity into Morecambe Bay, where, by their combined action, immense piles of sand are thrown up. The smaller Western portion of the current from the South runs along the East coast of Ireland, till it is brought up by meeting with a portion of the current from the North; this meeting takes place a little to the Westward of the Isle of Man, where a large surface of water some 25 miles in diameter exists with no perceptible current at any time, though the rise and fall at Springs is considerable, amounting to some sixteen feet.

When it is high water in Morecambe Bay, there are no tidal streams in the Irish Sea, the water being slack over every part of it.

When the water begins to fall at Morecambe Bay, the tidal streams in the Irish Sea are all reversed, and run out of it as fast as they ran in while the water was rising, and in opposite directions.

In the Bristol Channel there is a North-easterly current off the North-west coast of Cornwall and Devon, and an Easterly current off the South coast of Wales,



THIS PAGE IS LOCKED TO FREE MEMBERS

Purchase full membership to immediately unlock this page

DELVE INTO FANTASY, MAGIC, MYTHOLOGY & FOLKLORE

Forgotten Books'
Full Membership gives
access to 797,885 ancient
and modern, fiction and
non-fiction books.

Continue

*Fair usage policy applies

about $56^{\circ} 30'$ N. The stream is, however, still running into the Irish Sea through the North Channel.

With regard to the velocity of tidal streams, it is utterly impossible to give anything like an accurate estimate of their rate. Every gale of wind affects their rapidity, and in fact every breeze of wind, no matter how light, creates a small surface current, which, though having little effect upon Atlantic liners, may have a very serious effect upon vessels of light draught. Roughly, on our side of the English Channel the streams run at from $1\frac{1}{2}$ to $2\frac{1}{2}$ knots. On the French side, particularly in the neighbourhood of the Gulf of St. Malo, the streams are both irregular and very rapid.

In the Irish Sea the velocity of the tidal streams is from $1\frac{1}{2}$ to $2\frac{1}{2}$ knots. In the North Channel, however, they often attain a speed of 5 knots.

With regard to the tidal streams in the Bristol Channel, on the West coast of Scotland, on the East coast of England, and in the North Sea it may be said in a general way that the rate varies between $\frac{1}{2}$ knot at Neaps, and 2 knots or more at Springs, that near headlands and in narrow channels it may and does sometimes reach a rapidity of 5 knots. On the West coast of Scotland, between the Mull of Cantyre and the Island of Mull, the streams are both rapid and irregular, and this is characteristic also of the tidal streams in the Channels between the North coast of Scotland and the Orkney and Shetland Islands. This information doubtless seems somewhat vague, but it is the best I can give you.

When the navigator cannot ascertain the place of his ship by cross-bearing or by a knowledge of the land in sight, he should make an allowance for the tidal streams as above indicated when working out his Dead Reckoning. He should, however, never place implicit faith in the

position of his ship so arrived at, but in every case should constantly check it by the use of the lead.

The Admiralty Tide Tables, an admirable work, should be on board every vessel, and should be carefully studied. The information contained therein is compiled from the most reliable sources, and is as accurate as is possible under the ever-varying conditions of our wonderful climate. But when all is said and done, even the best information should be mistrusted, for tides are most precarious things, as every man knows who has had much experience of fishing off our Channel coasts. Such a one will not unfrequently perceive that the tide will, from causes quite unknown, run to the Eastward or the Westward, as the case may be, much longer than it ought to according to the highest scientific authorities, and, which is still more remarkable, according to the knowledge of the best local experts. In thick weather the cautious mariner will be very chary of placing too much reliance upon information as to the set, strength, and duration of tidal currents, even though derived from the best authorities on the subject.

CHAPTER VIII

CHARTS

PLACE a chart before you on a table, with the Northern end away from you. You will observe that on all charts of small surfaces of the Globe, there are here and there Compass Cards having their North points directed to the Magnetic North, a direction which generally makes a certain angle with the Meridians. When this is the case, the chart is what is called a '*Magnetic Chart.*' When, as is usually the case with charts representing large portions of the Earth's surface, such, for instance, as a chart of the North Atlantic, the Compass Cards have their North points coinciding with the Meridians, the chart is called a '*True Chart.*' You must remember that the Meridians in either case are always North and South *True.*

Under the title of the chart, information is given with regard to the meaning of certain abbreviations used, and also whether the soundings are given in fathoms or in feet; and, in the Admiralty Charts, the time of High Water, Full and Change, for the principal places and harbours on the chart is given.

The figures scattered all over that part of the chart representing the sea are the soundings at Low Water Ordinary Spring Tides; the small letters in italics under the sounding represent the nature of the bottom; a line



THIS PAGE IS LOCKED TO FREE MEMBERS

Purchase full membership to immediately unlock this page

SAVE \$3,999,994

Did you know we sell
paperback books too?

To buy our entire catalog
in paperback would cost
over \$4,000,000

Access it all now for
\$8.99/month

*Fair usage policy applies

Continue

on the dividers to the graduated Meridian on the right or left of the chart, and read off the Latitude.

To find the Longitude.—Measure the distance from the place with your dividers to the nearest Meridian, and apply that distance to the graduated Parallel at the top or bottom of the chart, and you have the Longitude.

To mark the ship's position on the chart.—The position of the ship is the point where a line representing your Latitude and a line representing your Longitude cut.

Lay the edge of the parallel ruler on the Parallel nearest to the place. Shift it to the exact Latitude of the place as marked on the graduated Meridian (if your ruler will not reach the graduated Meridian measure the Latitude of the place North or South of that Parallel with your divider, and make a dot on the chart in such a position that your rulers will reach it : work them up to the dot, and leave them there). The edge of the ruler is now on the Latitude of the ship. Then with the dividers measure on the graduated Parallel the distance East or West from the nearest Meridian. From the same Meridian apply that distance to the edge of the parallel rulers, and you have the Longitude of the ship.

To find your place by Bearings of the land.—The simplest method is by cross Bearings, that is to say by simultaneous Bearings of two objects so situated that the Bearings will cut each other at an angle sufficiently broad to make the point of intersection clean and clear. Take the Compass Bearing of two objects which are marked in the chart. Turn them into Correct Magnetic Bearings. Place your parallel rulers on the Correct Magnetic Bearing on the nearest Compass Card on the chart, and move them up to the first object, and draw a line. Proceed in the same way with the second object, and draw another line. The point of intersection is the ship's position.

In diagram No. 32 let A and B be two points of land bearing from the ship NW and NE $\frac{1}{2}$ N respectively. Then O, the point of intersection of the two Bearings, is the position of the ship.

FIG. 32

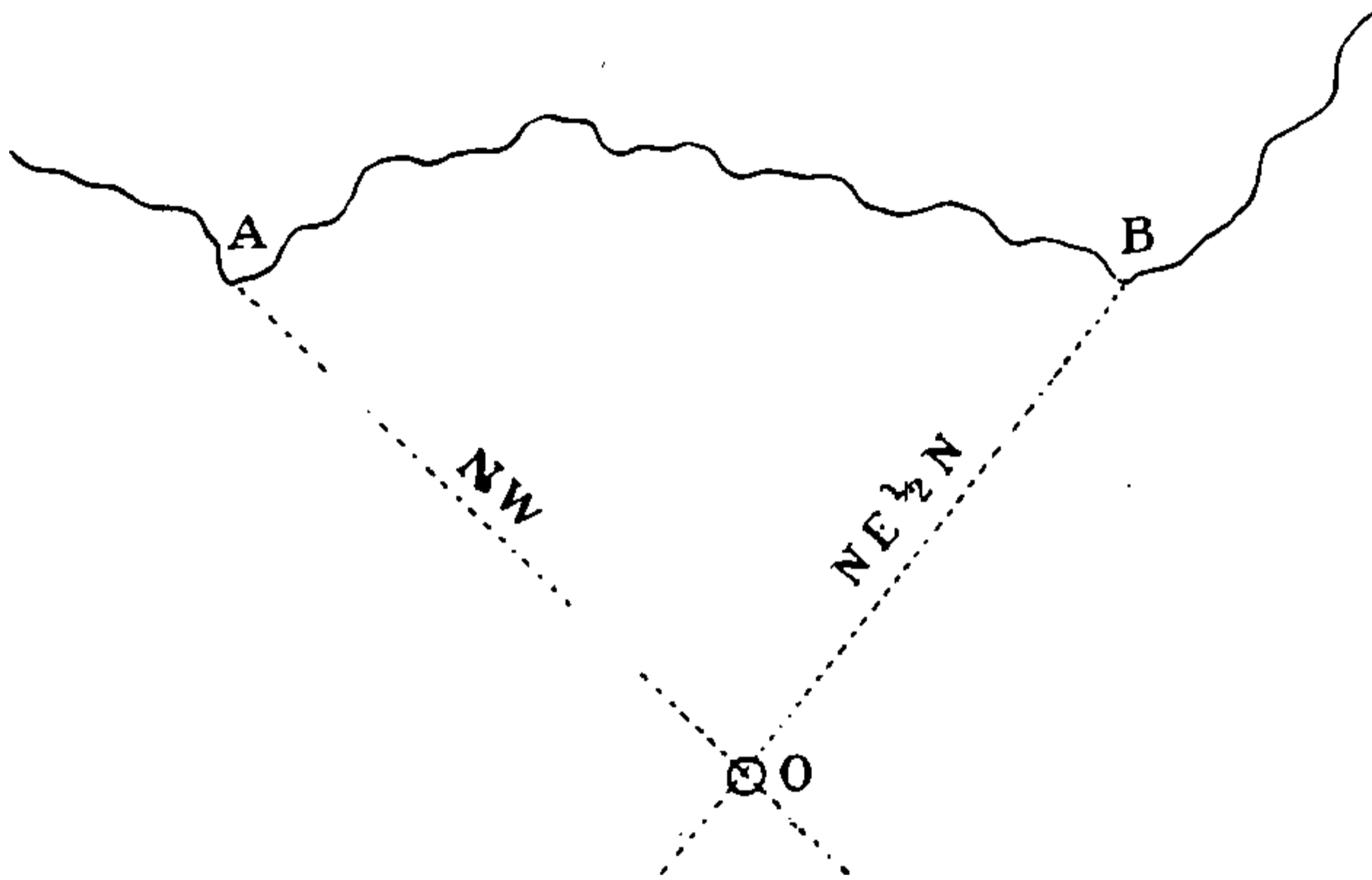

It may be that you cannot get a Bearing by Compass of the second object—some portion of the ship may intervene. In such a case measure the angle between the first object and the second object with a sextant. By applying this angle to the Bearing of the first object you will get the Bearing of the second object. Thus if the Bearing of the first object was North, and the angle between the first and second object was 60° , the Bearing of the second object will be N 60° E if it is to the right of the first object, and it will be N 60° W if it is to the left of the first object.

To find the ship's position by two Bearings of the same object, and her distance from it at the time the second Bearing was taken.—Take the Bearing by Compass of an object, say A; turn it into Correct Magnetic, and draw a

line from A as in the preceding case. After the ship has run a sufficient distance to make a good broad angle, take another Compass Bearing of A, turn it into Correct Magnetic, and draw another line from A on that Bearing. Find the Correct Magnetic Course, and the Distance run by the ship in the interval between taking the two Bearings. Put the Distance on your dividers, lay your parallel rulers on the Ship's Course, by the nearest Compass Card on the chart, and move them backwards or forwards along the lines of Bearings till the Distance on your dividers measures the Distance between the two Bearings along the edge of the rulers, and draw a line; the spot where this line intersects the line of the second Bearing is the position of the ship. Then take off the Latitude and Longitude of the ship's position from the chart. Measure the Distance from the ship's position to the object on shore along the second line of Bearing, and there you are.

FIG. 33

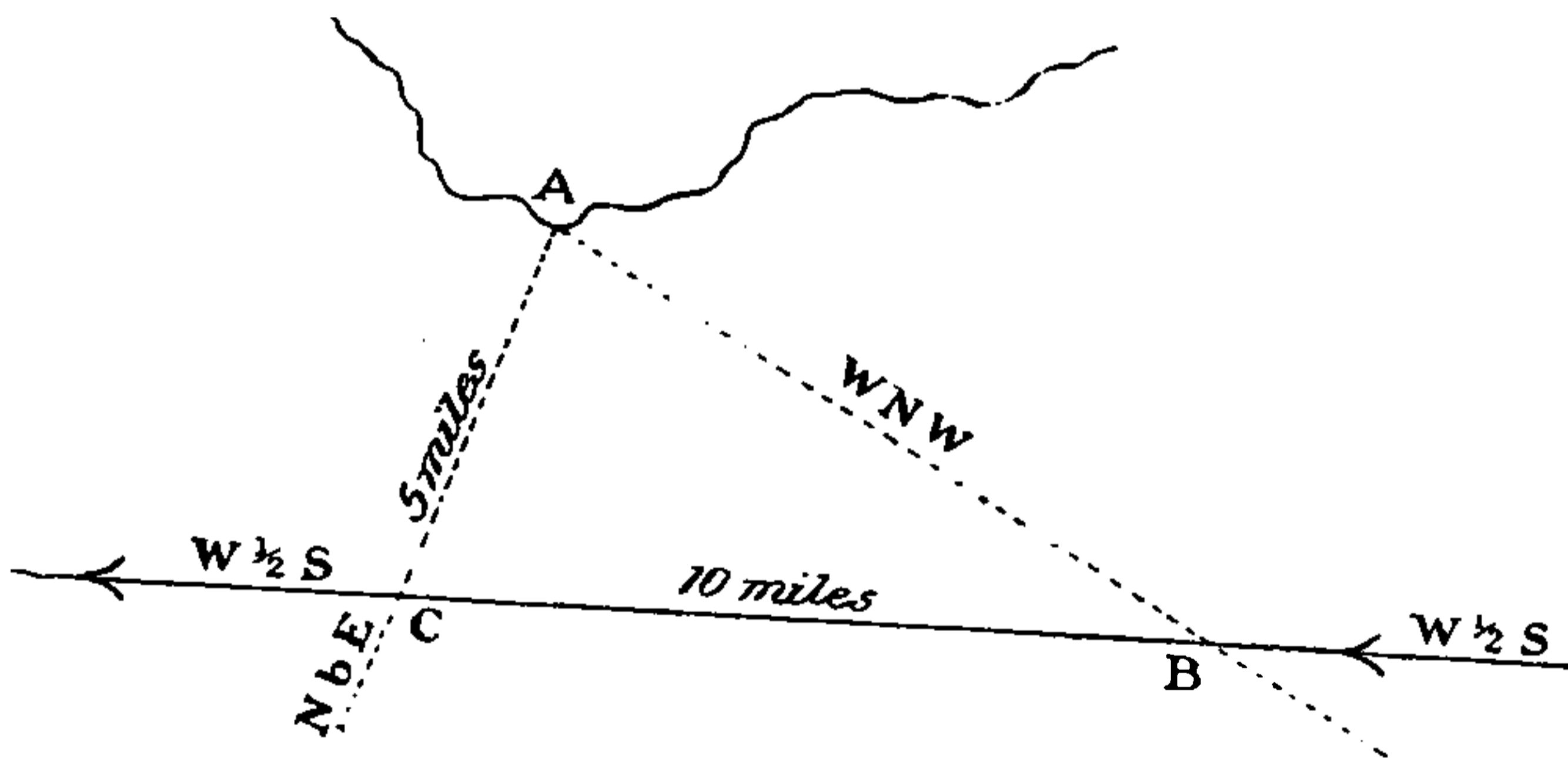

In diagram No. 33 let A be the point of land and suppose the Course of the ship to be $W \frac{1}{2} S$ and the distance run ten miles. The first Bearing taken of A is WNW , then after the ship had run ten miles on her Course A bore $N b E$.



THIS PAGE IS LOCKED TO FREE MEMBERS

Purchase full membership to immediately unlock this page

DELVE INTO FANTASY, MAGIC, MYTHOLOGY & FOLKLORE

Forgotten Books'
Full Membership gives
access to 797,885 ancient
and modern, fiction and
non-fiction books.

Continue

*Fair usage policy applies

If a ship is sailing in the direction $A B C$ she can determine at what distance on that course she will pass from the headland D by noting the run between the two positions A and B , when the headland bears 26° and 45° on the bow respectively. Then $A B$ is equal to $C D$, or the run of the ship is equal to the Distance at which she will pass from the headland.

FIG. 34

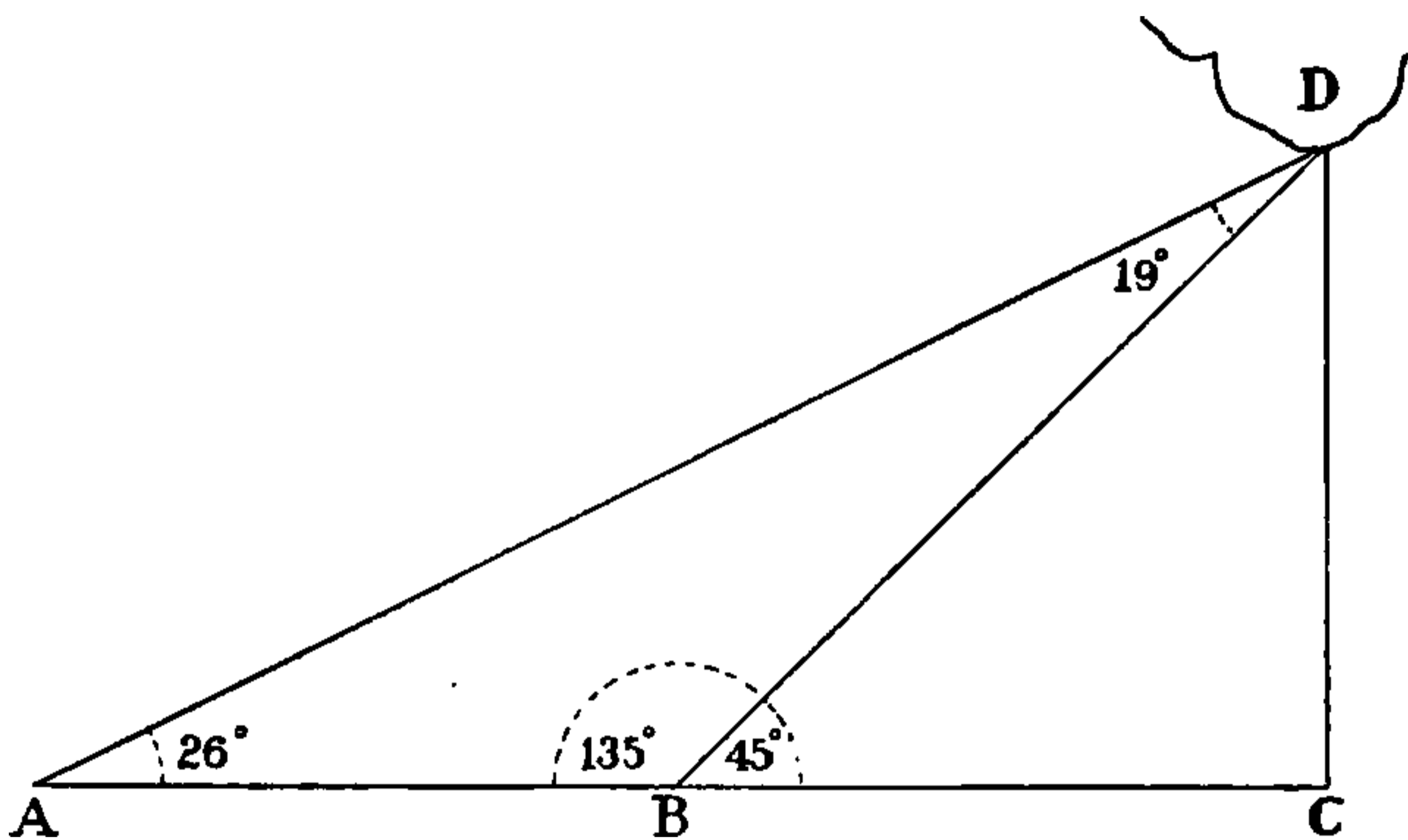

To find the Course and Distance from one place to another on the chart.—Lay the edge of the parallel rulers on the two places, work the edge of the parallel ruler till it cuts the centre of a Compass on the chart, and read off the Course, which on a Magnetic chart will be Correct Magnetic; correct it for Deviation to get a Compass Course. If you are using a True Chart, the Course you will obtain will be a True Course, and must be corrected for Variation also. Measure the Distance by the dividers, taking care if it involves much Difference of Latitude to measure it off on such a portion of the graduated Meridian as will lie about half-way between the Latitude of the two places.

The Examination for Second Mate requires the candi-

date to find the Course to steer on either a True or a Magnetic Chart, and the distance from one point to another; and to fix the position by Cross Bearings or from two Bearings of the same object, with the Run between.

To allow for a current.—If you know that the tide or any other current will set you so much an hour in such and such a direction, allowance must be made for it, which can only practically be done by assuming that you will traverse the whole distance at a certain rate. Draw

FIG. 35

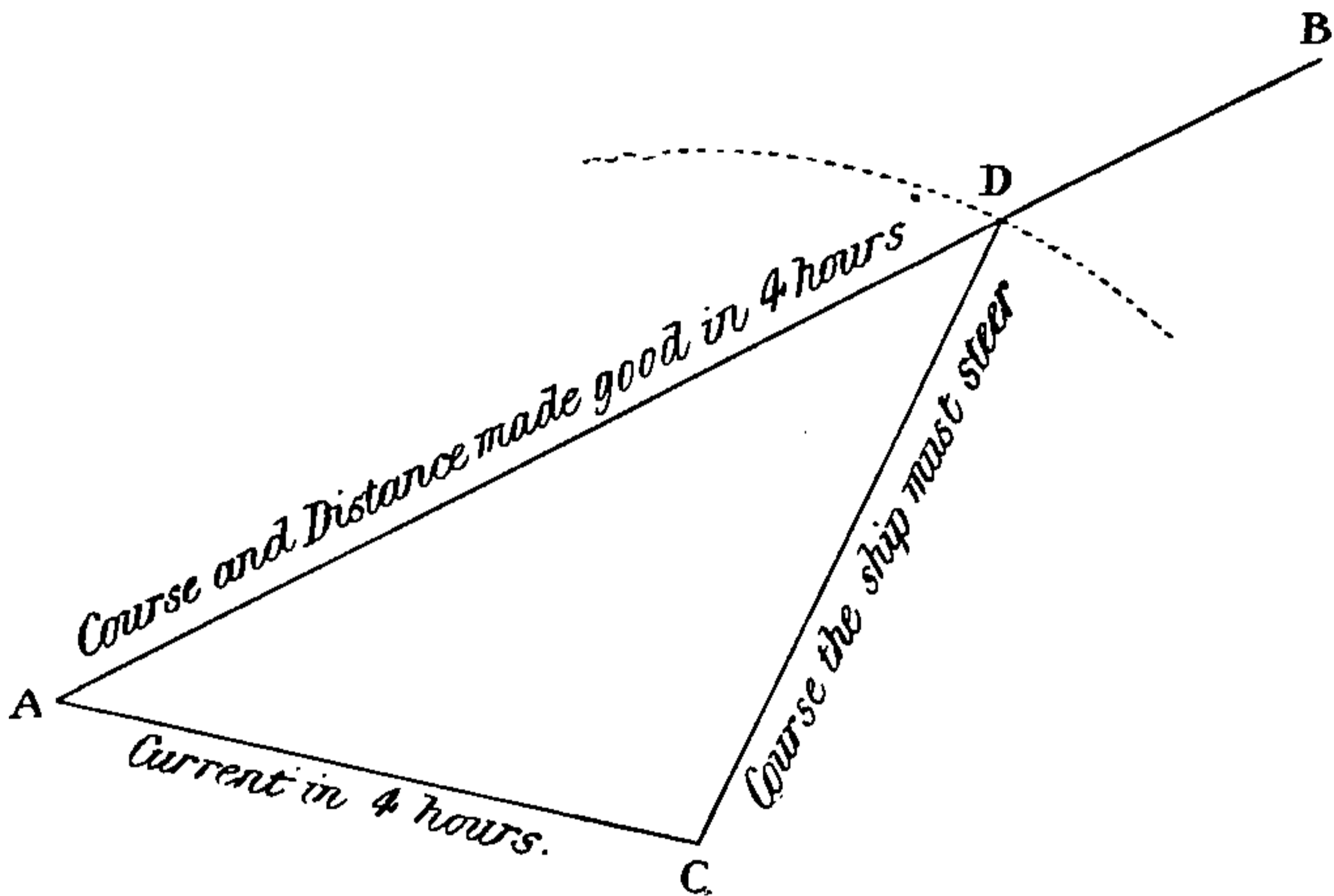

a line between the two places, say from A to B, and ascertain the Course. If the current sets directly towards your destination B, steer the same Course; and, to ascertain the ship's position, add whatever Distance the current has set you to the Distance run by the ship. If the current is setting directly from B towards A, steer the same Course, and your position at any time will be the run of the ship less the Distance that the current has set you. But if the current sets across your Course, proceed as shown in the above diagram.

From A, your point of departure, draw a line in the direction in which the current sets. Measure along this line the Distance the current will have set you in four hours, and mark that spot C. Open your dividers to the Distance you will have sailed in the four hours; then, with one point of the dividers on C, sweep the other round till it cuts the line of the Course. Call that point of intersection D. Then CD is the Course to steer in order to reach B, and AD is the Distance made good in four hours.

FIG. 35

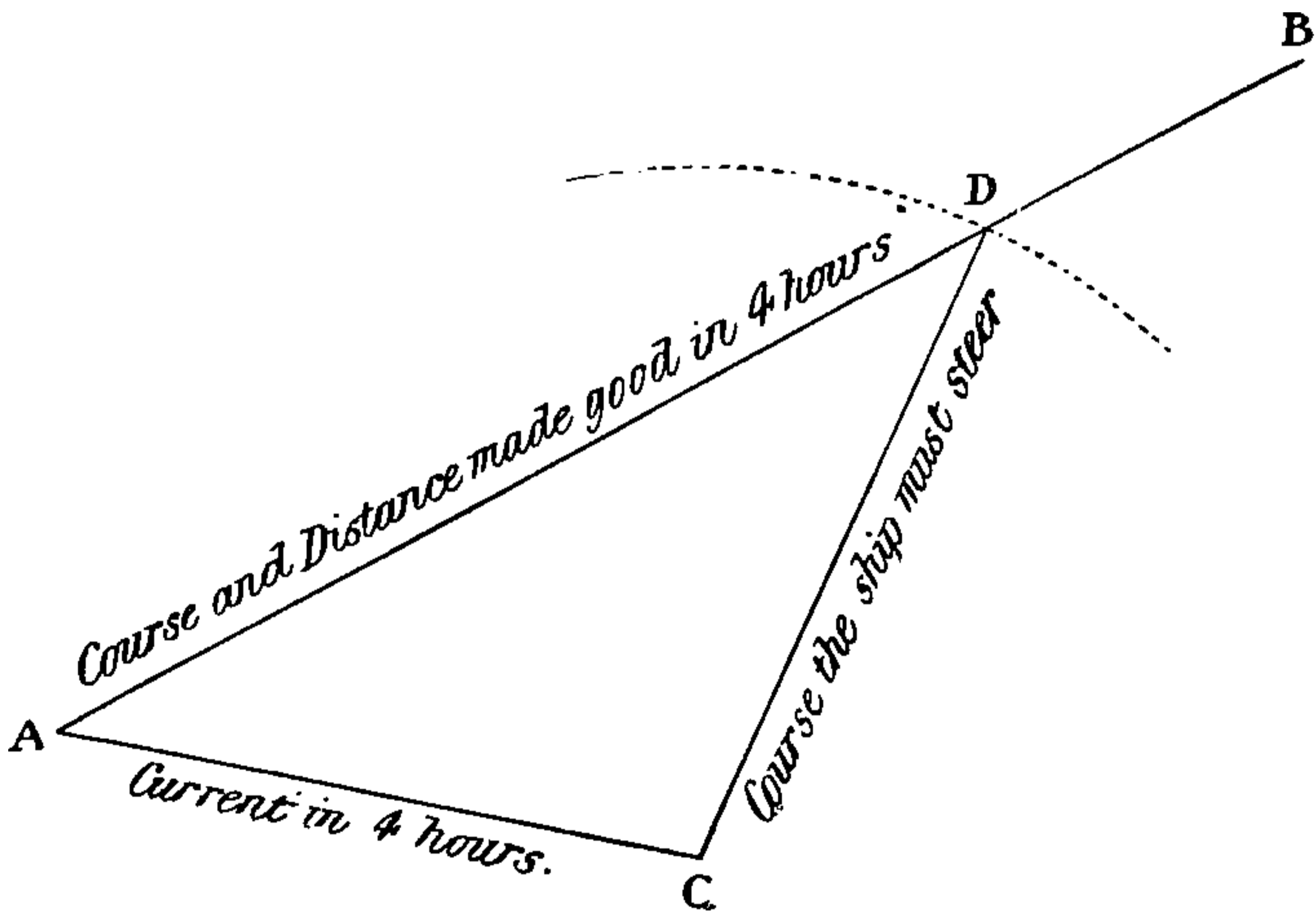

The Course will be a Course Correct Magnetic if you are using a Magnetic chart, or True if you are using a True chart; and must in either case be converted into a Compass Course.

The Examination for Ordinary Master requires the candidate to find on a chart the Course to steer to counteract the effect of a given current, and to find the Distance the ship will make good towards a given point in a given time.



THIS PAGE IS LOCKED TO FREE MEMBERS

Purchase full membership to immediately unlock this page

SAVE \$3,999,994

Did you know we sell
paperback books too?

To buy our entire catalog
in paperback would cost
over \$4,000,000

Access it all now for
\$8.99/month

*Fair usage policy applies

Continue

Charts (Theoretical)

You need not read this unless you are interested in the subject or are contemplating taking an Extra Master's Certificate.

The Earth being a sphere, the representation of any portion of its surface as a flat surface must necessarily involve a distortion. For the convenience of navigators and travellers, however, it is necessary that the spherical surface of the Earth should be represented or projected on a flat surface. There are two such projections commonly used, namely, Mercator's Projection, and the Gnomonic, or Polar Projection.

With regard to the latter, as it can only be used when in very high Northern or Southern Latitudes, and I don't expect my readers to become polar explorers, it may be dismissed in a very few words. The Pole is taken as the centre from which radiate the Meridians, and the Parallels of Latitude are drawn as circles round the Pole at distances such as are proportionate to the exaggerated distances apart of the Meridians, as they increase their distance from the Pole. That is the principle of the Gnomonic Projection, with which we have nothing further to do.

The charts in universal use are those drawn on Mercator's Projection.

In a Mercator's Chart the Meridians are drawn parallel to one another, whereas, as you know, they are not really so, being farthest apart at the Equator and meeting at the Poles. The immense advantage derived from drawing the Meridians parallel to each other is that a ship's Course—the angle it makes with the Meridian—is drawn as a straight line, whereas on a sphere it would have to be drawn as a curve, as the following diagrams show.

In both of the figures the angles at $c d e f g$, that is the angles formed by the Course $A B$ cutting the Meridians, are all equal to each other. The angles being equal the Course in fig. 36, which represents the converging Meridians, must be drawn as a curved line $A B$, and all the angles formed by the Course and Meridians would be spherical, and problems on a sphere can only be solved by Spherical Trigonometry.

FIG. 36

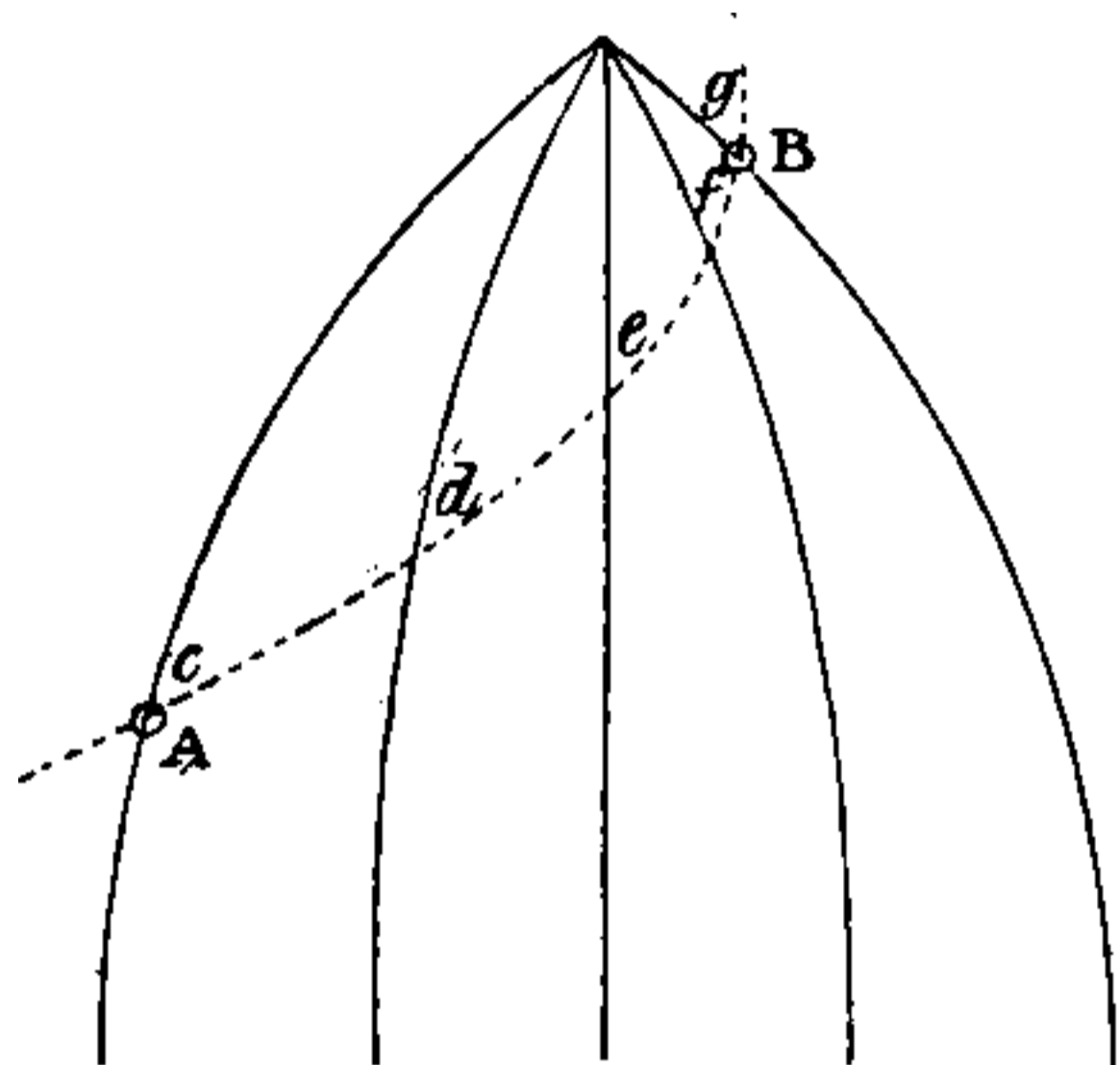
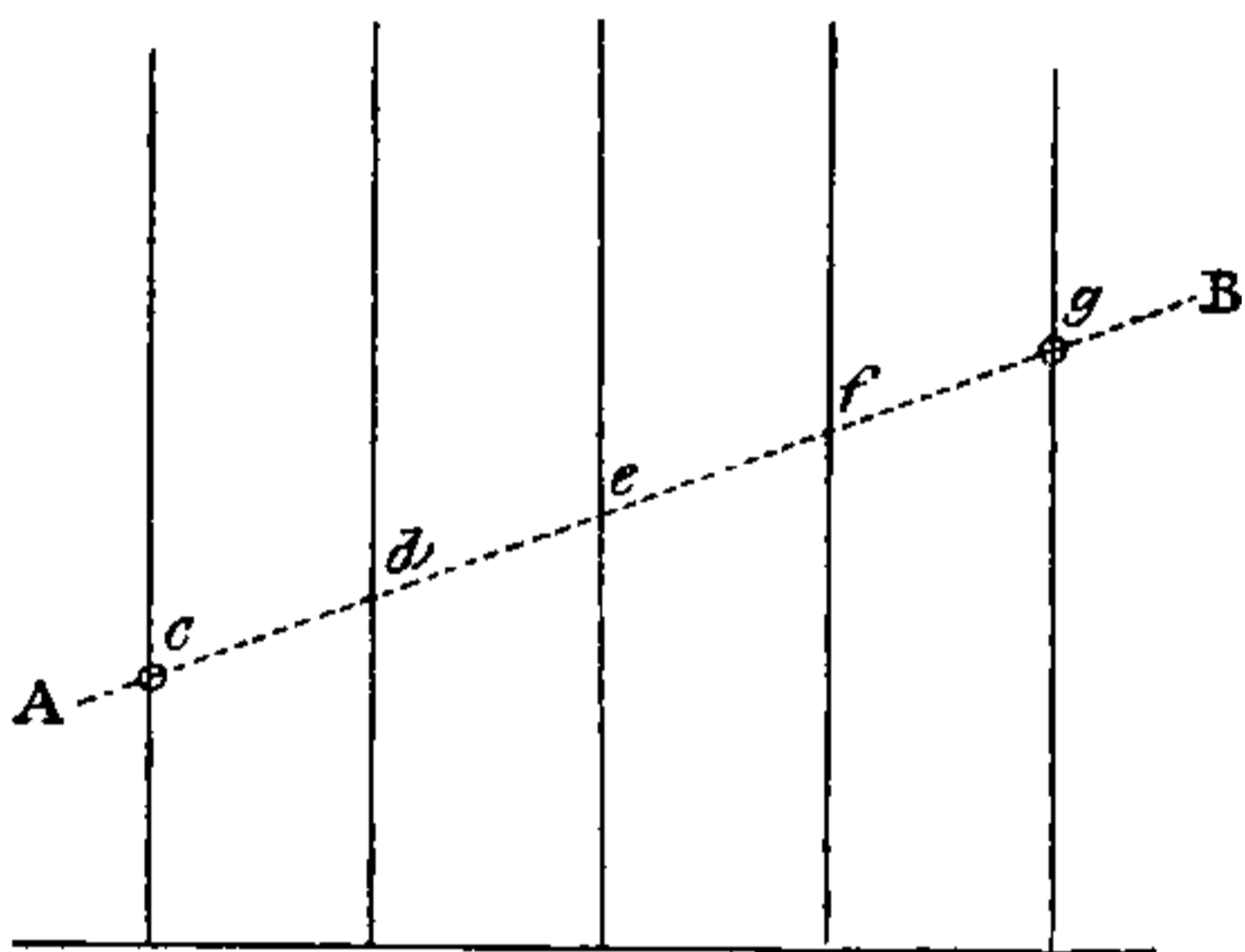

FIG. 37



But in fig. 37 the Meridians are represented as parallel lines upon a plane surface, and the Course is drawn as a straight line upon it; all the angles are therefore plane angles, and all problems on a plane can be solved by the much simpler processes of Plane Trigonometry. The 'Sailings,' a 'Day's Work,' and all the problems solved by the help of Traverse Tables, would be impracticable on the supposition that the Earth was what it really is, a sphere. Mercator's Projection is therefore invaluable to the mariner.

Now the Meridians being drawn parallel to each other, on a Mercator's Chart, it is evident that everywhere except on the Equator they are too far apart, the exaggeration becoming greater and greater as the Pole is approached. To preserve the relative proportions between the Difference of Latitude and Departure, the distance between the Parallels of Latitude is increased in the same proportion

as the distance between the Meridians has been exaggerated. In other words, the following proportion is made. As the Departure in any given Latitude is to the corresponding Difference of Longitude, so is the Difference of Latitude to the difference between any two Parallels required. Thus in Latitude 60° , the Departure corresponding to 1° of Difference of Longitude equals $30'$. Suppose you want to know how far apart the Parallels of $59^\circ 30'$ and $60^\circ 30'$ must be drawn on a Mercator's Chart. Then as $30'$ is to 1° so is 1° to the distance required.

$$\begin{array}{r} \text{As } 30 : 60 :: 60 : x \\ \quad \quad \quad \underline{60} \\ \quad \quad \quad 60 \\ \quad \quad \underline{30) 3600} \\ \quad \quad \quad 120 \text{ answer} \end{array}$$

The answer is 120, and these Parallels must be drawn 120' apart. I would impress very strongly upon you that though these Parallels are drawn 120' apart, yet they are of course only 60 nautical miles apart, and will measure only 60' apart on the graduated Meridian on the side. Each degree of Latitude on the graduated Meridian at the side of the chart is divided into 60'. Also that the Meridians, although 60' of Longitude apart, are really only 30 nautical miles apart. This is why it is so important to remember that Distances on a Mercator's Chart, which is drawn with North and South at the top and bottom, are always measured on the side of the chart, and as far as possible in a line with the positions whose Distance apart is required, because with every degree of Latitude the length of the nautical mile on the chart alters. Remember that this is always the case except with some charts which for convenience sake are drawn with the Meridians running from side to side, and the Parallels from top to bottom; in which case of course the Distance must be measured at the top or bottom.



THIS PAGE IS LOCKED TO FREE MEMBERS

Purchase full membership to immediately unlock this page

DELVE INTO FANTASY, MAGIC, MYTHOLOGY & FOLKLORE

**Forgotten Books'
Full Membership gives
access to 797,885 ancient
and modern, fiction and
non-fiction books.**

Continue

*Fair usage policy applies

The theory, in case you would like to know, is :

In Latitude x the distance between the Parallels is drawn as $60 \times \text{Sec } x$, or in other words the scale of the chart is greater in Latitude x than at the Equator in the proportion of $\text{Sec } x : 1$. This means that the same length on the earth is represented by a line on the chart longer in this proportion. Reference to the diagram shows why this is the right proportion.

FIG. 38

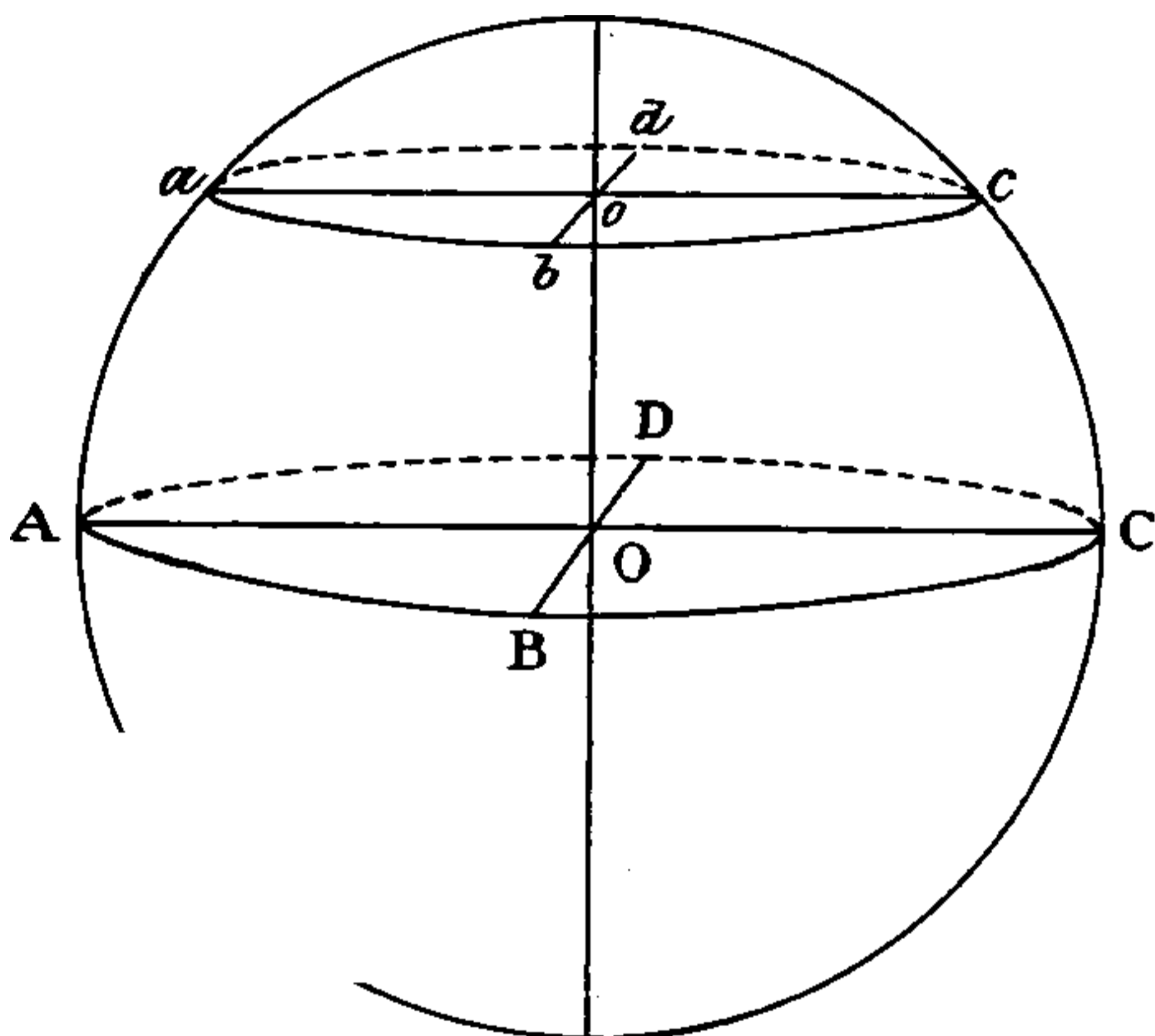

The Parallel $a b c d$ is represented by the same length as the Equator $A B C D$; that is, the scale of the chart is increased in the Departure direction (and, of course, equally in the Latitude direction to balance this) in the

proportion $\frac{A B C D}{a b c d}$. The proportion $\frac{A B C D}{a b c d} = \frac{O C}{o c}$ because

the circumference of a circle is always proportional to the radius. And $o c = o r$, so that $a b c d$ is represented

by a line too long in the proportion $\frac{O c}{o c} = \text{Cosec } c O o = \text{Sec } c o c$ which is Sec Latitude.

So much for the theory on which a chart is constructed.

In the Board of Trade Examination a candidate for an Extra Master's Certificate is required to draw a chart on Mercator's Projection, and even if you are not an aspirant for extra honours an explanation of the method may help you to understand a chart, and anyhow you need not read it if you don't like.

The easiest way to construct a Mercator's Chart is in the following manner. First draw a horizontal line to represent that Parallel of Latitude in your proposed chart which is nearest to the Equator. Divide this Parallel into any convenient number of equal parts, and draw, upwards if in North Latitude, and downwards if in South Latitude, lines at right angles to the Parallel. These lines will, of course, be the Meridians. Next with a protractor lay off from either end of the Parallel, and in a direction away from the Equator, a line at a certain angle to the Parallel; in order to find what this angle should be, add together the Latitudes of the Parallel you start from, and of the Parallel you wish to draw, and divide by two; this mean is the angle required. Measure with the dividers the distance along the line so drawn, from the end of the first Parallel to the point where the line intersects the next Meridian; this distance measured along any Meridian from the first Parallel will give you the position of the second Parallel, and similarly each successive Parallel is found.

Suppose you want to construct a Mercator's Chart between the Parallels of 50° and 52° North, and the Meridians of 1° East and 5° West on a scale of one inch to a degree of Longitude. Proceed as follows:

The Parallel of 50° N is first drawn. Then it is divided into six parts, and the Meridians are drawn perpendicular to the Parallel. Next the angle $50^{\circ} 30'$, the mean of Latitudes 50° and 51° , is laid off from the end of

the Parallel, and the place where the line cuts the next Meridian gives the distance between the Parallels of 50°

FIG. 39

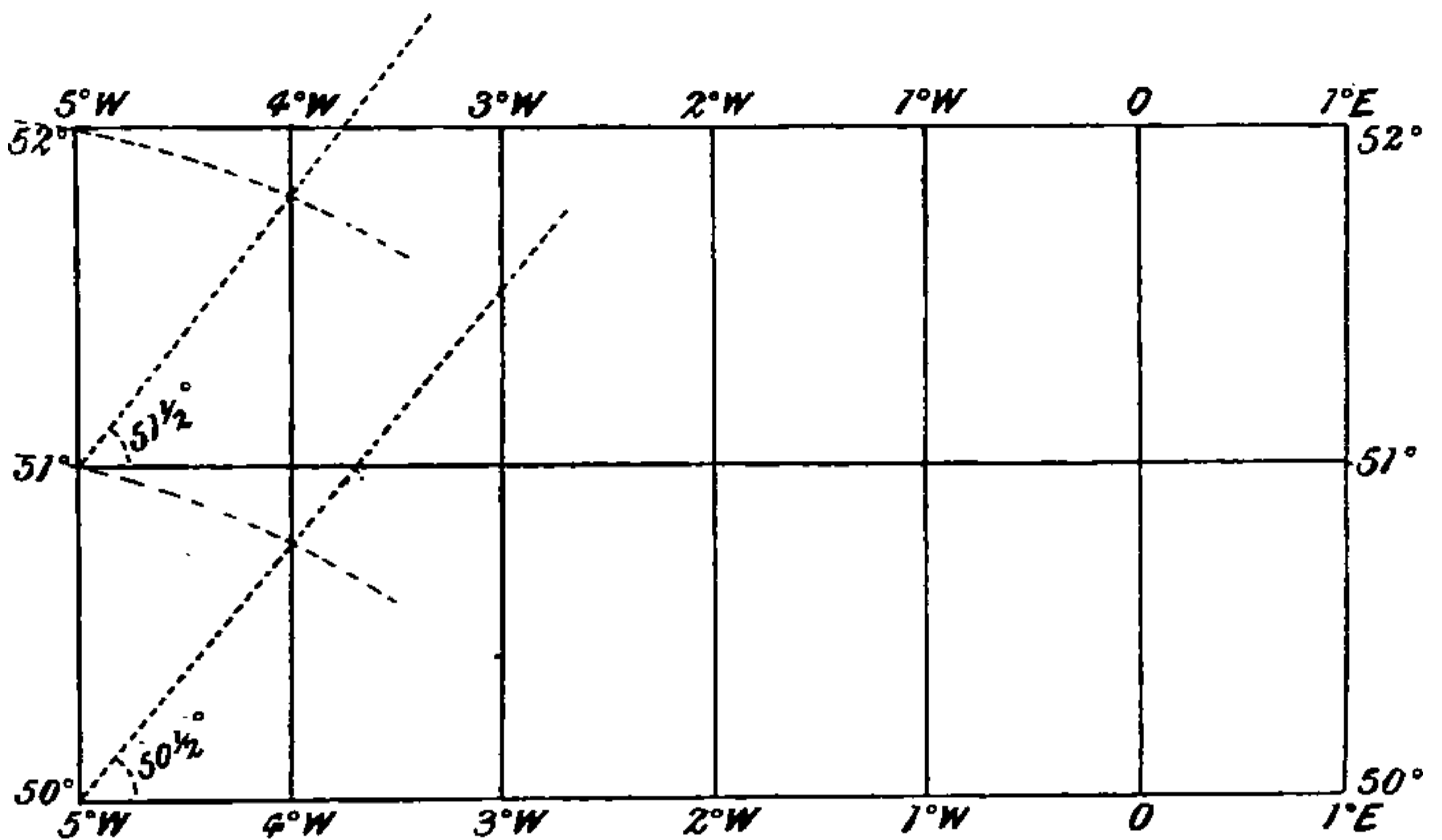

and 51° . Thus the fifty-first Parallel is found; and from the fifty-first the fifty-second is found, and so on. To divide the degrees into minutes is a mere matter of detail, but perhaps it would be well to suggest a method.

If you want to divide AB into six equal parts, the readiest method is to lay off a line AC at any angle with AB .

FIG. 40

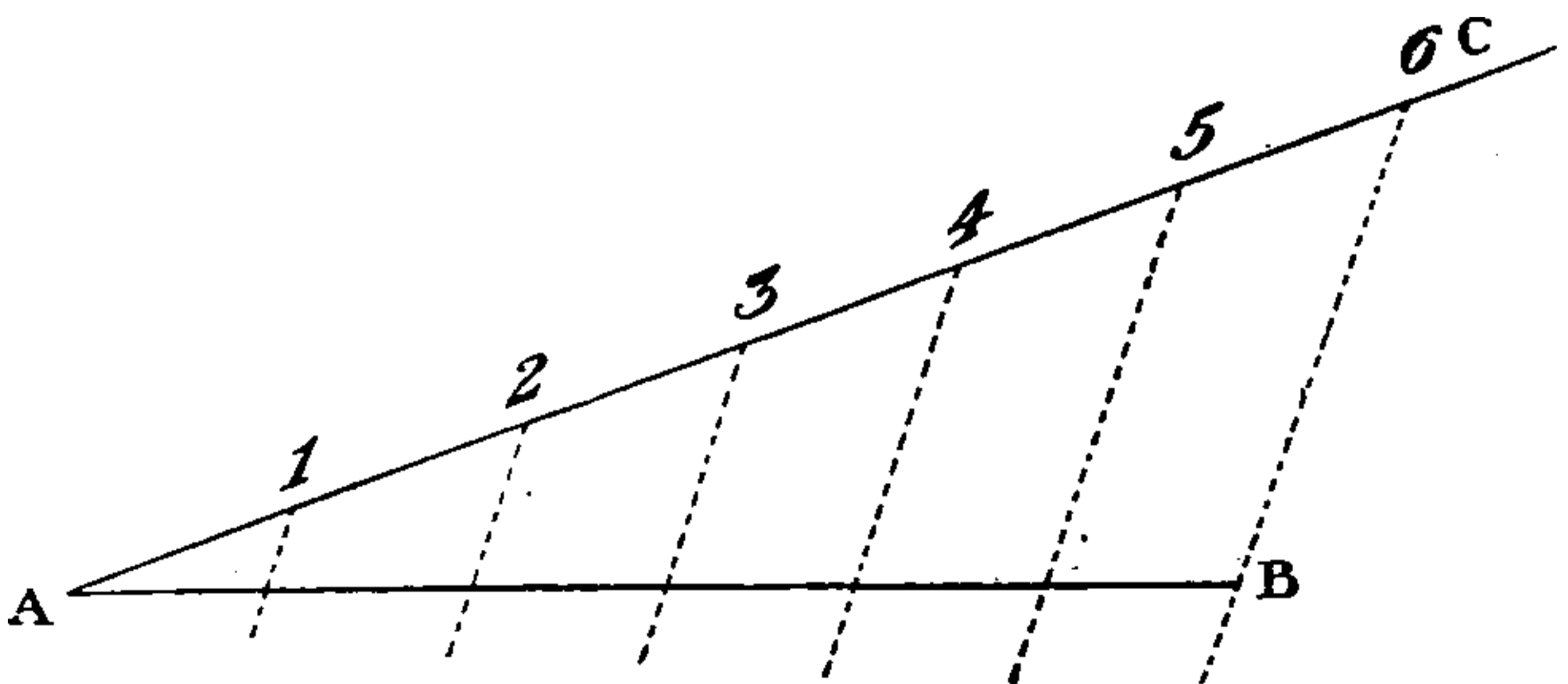

Open out four dividers to any length approximately correct, and with them dot down along the line AC six equal



THIS PAGE IS LOCKED TO FREE MEMBERS

Purchase full membership to immediately unlock this page

SAVE \$3,999,994

Did you know we sell
paperback books too?

To buy our entire catalog
in paperback would cost
over \$4,000,000

Access it all now for
\$8.99/month

*Fair usage policy applies

Continue

PART II
NAUTICAL ASTRONOMY

CHAPTER IX

DEFINITIONS NECESSARY IN NAUTICAL ASTRONOMY

Most of the definitions collected here will be found in earlier or later chapters, but they are given here for convenience of reference.

A Second Mate is required to write a short definition of Astronomical and Nautical terms, and to draw a rough sketch or diagram to illustrate their meaning.

A plane is the real or imaginary flat surface contained within the real or imaginary bounds of any figure. For instance, take a flat round looking-glass. The surface of the glass is the plane of the circle enclosed by the frame of the glass, and the frame is the circumference of the circle. A plane may be indefinitely extended in all directions.

A circle is a plane figure bounded by a line called the circumference, every part of which is equidistant from a point inside the circle called its centre. The diameter is any straight line passing through the centre, and dividing the circle into two equal parts.

A radius is any straight line drawn from the centre of a circle to its circumference. Every circle, no matter

what its size, is divided into 360 degrees. Any portion of the circumference of a circle is called an 'arc' of the circle. The two radii joining the extremities of an arc with the centre form an angle at the centre, which always contains the same number of degrees as the arc and measures the arc. This is true, whatever the size of the circle and length of the radii may be.

Any arc is said to be subtended by the angle formed by the radii drawn from its extremities to the centre of the circle.

Each degree is divided into 60 minutes of arc, and each minute into 60 seconds of arc. Half a circle is called a semi-circle, and contains 180 degrees. A quarter of a circle is called a quadrant. The angle subtended by a quadrant is one of 90 degrees, and is a right angle. The angle subtended by an arc less than a quadrant is an acute angle, and is of less than 90 degrees. The angle subtended by an arc greater than a quadrant, but less than a semi-circle, is an obtuse angle, and is of more than 90 degrees.

The complement of an angle is what it wants of 90° . The supplement of an angle is what it wants of 180° .

A sphere is a solid body, every portion of the surface of which is equidistant from a point inside called its centre. The Earth is not a sphere, being slightly flattened at the Poles, but for nearly all Navigational purposes it is treated as a sphere.

The axis of the Earth is the imaginary line on which it rotates. The extremities of the axis are the Poles.

The Equator is an imaginary line drawn round the Earth, every portion of which is equidistant from the Poles.

A circle whose plane passes through the centre of the Earth and divides it into halves is called a Great Circle: the Equator is therefore a Great Circle.



THIS PAGE IS LOCKED TO FREE MEMBERS

Purchase full membership to immediately unlock this page

DELVE INTO FANTASY, MAGIC, MYTHOLOGY & FOLKLORE

**Forgotten Books'
Full Membership gives
access to 797,885 ancient
and modern, fiction and
non-fiction books.**

Continue

*Fair usage policy applies

passing through the Zenith and perpendicular to the Horizon.

The Altitude of a Heavenly Body is the arc of a circle of Altitude between the centre of the body and the rational Horizon ; or it is the angle at the centre of the Globe between the rational Horizon and a line from the centre of the body to the centre of the Globe ; or it may be called the angular height of the centre of the body above the rational Horizon.

The Azimuth of a Heavenly Body is the angle the vertical circle through it makes with the Meridian.

The Latitude of a place is the arc of the Meridian between the Equator and the place.

Latitude is measured in degrees, minutes, and seconds of arc, from $0^{\circ} 0' 0''$ at the Equator, to 90° at the Poles, and is named North if North of the Equator, and South if South of the Equator.

The Longitude of a place is the arc of the Equator between the Meridian of Greenwich and the Meridian of the place. It is named East for 180° to the eastward of the Meridian of Greenwich, and West for 180° to the westward of the Meridian of Greenwich.

A degree of Longitude on the Equator is 60 nautical miles or knots in length. As Meridians converge and meet at the Poles, degrees of Longitude become gradually shorter until they disappear at the Poles. The length therefore of a degree of Longitude depends upon the Latitude.

The Ecliptic is really the track of the Earth's orbit round the Sun ; but it is looked upon, for Navigational purposes, as the path that the Sun describes in the heavens in the course of a year.

Owing to the fact that the Earth's axis is inclined to the plane of her orbit, the Ecliptic and Equinoctial cut

each other at two opposite points. One of these points, and the only one with which we have to deal, is called the 'First Point of Aries.'

The Declination of a celestial body is the arc of a celestial Meridian between the Equinoctial and the centre of the body, or it is the angle at the centre of the Earth between the Equinoctial and a line drawn from the centre of the body to the centre of the Earth. Declination is named North or South according to whether the body is North or South of the Equinoctial. As the Equinoctial is an indefinite extension of the plane of the Equator, Declination corresponds in all respects to Latitude.

The Polar Distance of a celestial body is the arc of a celestial Meridian intercepted between the elevated Pole and the centre of the body. In North Latitude the North Pole is the elevated Pole; in South Latitude the South Pole is the elevated Pole.

The Right Ascension of a Heavenly Body is the arc of the Equinoctial intercepted between the First Point of Aries and the celestial Meridian passing through the centre of the body, or it is the angle formed at the celestial Pole by the Meridian of the body and the Meridian passing through the First Point of Aries. It is measured from the First Point of Aries to the eastward right round the Equinoctial. As Right Ascension is measured from a natural position, namely the First Point of Aries, right round the circle, and Longitude is measured from an arbitrary position, the Meridian of Greenwich, half round the circle in opposite directions, Right Ascension and Longitude are in no way connected. Right Ascension is always measured in terms of time.

The best way of understanding clearly what is meant by these various terms is to follow them out with English's 'Globe Star-finder,' described in Chapter XI.

You will then see exactly what is meant by Great Circle, Small Circle ; Altitude, Azimuth ; Latitude, Longitude ; Right Ascension, Declination ; Meridian, Parallel, Zenith, Horizon, etc.

Dip, Semi-Diameter, Horizontal Parallax, Parallax in Altitude and Refraction are all fully explained later on, with explanatory diagrams.



THIS PAGE IS LOCKED TO FREE MEMBERS

Purchase full membership to immediately unlock this page

SAVE \$3,999,994

Did you know we sell
paperback books too?

To buy our entire catalog
in paperback would cost
over \$4,000,000

Access it all now for
\$8.99/month

*Fair usage policy applies

Continue

the arc would measure only half the altitude or angle observed. The explanation of this is given later on.

A metal arm, pivoting on the centre of the circle of which the Sextant is a part, rests on the top of the frame, and moves freely on its pivot. This is called the Radius Bar. Its outer end is fitted with a vernier which fits close down on the graduated arc. The vernier is an ingenious device, named from its inventor, for determining with increased accuracy the position of the arrow-head which defines the position of the arm, relatively to the divisions on the arc. This is done by dividing it so that each division is $\frac{1}{60}$ th part less than one division of the arc. The bar has two screws; the one underneath the frame is used to clamp the movable arm to the arc, and is called the Clamp screw; the other, called the Tangent screw, is fitted on the outer end of the bar, and is used for moving the vernier very slowly over the arc.

On the arm on top of the centre pivot is fixed a small mirror perpendicular to the plane of the frame, and in the same line as the metal arm: this is the Index Glass.

On the frame, and perpendicular to it and parallel to the Index Glass when the vernier is set to zero on the arc, is fixed another glass. The half of this glass nearest to the frame is quicksilvered at the back, in order to make a mirror of it, while the other half is left transparent: this is the Horizon Glass.

Opposite to the Horizon Glass, and parallel to it, is a metal collar on a stem. The stem, which is perpendicular to the plane of the instrument, fits into a female screw fixed through the metal frame, which enables the observer to raise or lower the collar to a limited extent by means of a milled ring underneath. Two sets of coloured glass shades are fitted on pivots above the frame, and are so

placed as to enable the observer to shade both or either of the mirrors.

Small screws are fitted to the Horizon Glass and Index Glass for the purpose of making certain adjustments, of which I will speak later on.

A Sextant is a delicate instrument, and should be handled with care. It should never be held by the arc or by either the Index or Horizon Glasses. It should be lifted out of its box by part of the frame, and then taken hold of by the handle underneath. It should never be put down with the handle up; and legs are fixed to the frame to support it on the handle side. The navigator who is worth his salt will cherish and take the utmost care of this invaluable instrument, and he will find himself richly repaid by the confidence he will gain in the observations taken with it. A nautical instrument maker in a large way of business once stated that he could tell instantly by the way in which a man handled a sextant whether he was a good navigator or the reverse, and I can well believe him.

A few words on the practical use of the instrument may be useful. Let us suppose that you are going on deck to observe the Meridian Altitude of the Sun for the purpose of ascertaining your Latitude.

Take your sextant out of the box, and hold it by the handle with your right hand (if you are left-handed you may be obliged to have a sextant specially made) face up. Take hold of the vernier end of the arm with your left hand, and having first slackened the clamp screw, move it till the arrow on the vernier is nearly at zero. Next, having, if circumstances require it, adjusted some of the shades so as to dull the brilliancy of the image of the Sun, and if necessary of the Horizon also, look through the collar and Horizon Glass towards the Sun, and you will see a shaded image of the Sun in the quicksilvered part of the

Horizon Glass. Now, holding the sextant vertical, push the radius bar away from you, and the image of the Sun will fall—follow it down by turning the sextant in a vertical plane, till the reflected Sun is brought down to the Horizon line, which you will see through the transparent part of the Horizon Glass ; then turn the sextant horizontal, and screw tight the clamp screw. Take from your box one of the small brass telescopes ; focus it to your sight as you would any other telescope, and screw it into the collar ; look at the Horizon under the Sun, holding the sextant vertical, and you will see the reflected Sun and the Horizon. Your object is to make one edge of the Sun, either the lower or the upper limb, touch the Horizon exactly, and you accomplish this by turning the tangent screw with the second finger and thumb of your left hand until exact contact is made, at the same time supporting the arc with the fore-finger of the same hand. To give greater steadiness it is a good plan to grasp the handle of the sextant with the fingers of your right hand, and place the thumb round the collar screw ; makers object, but I never found that it injures a sextant. Keep the Sun touching the Horizon till it ceases to rise—you then have the Meridian Altitude on your sextant. After a little practice learn to use the inverting telescope.

The next step is to read off the angle. A small microscope is fitted on top of the radius bar, so as to pivot over the vernier. On looking through this, having first focussed it to your sight, you will see the aluminium arc and the vernier. The aluminium arc is divided into degrees and sixths, every sixth part of a degree being of course ten minutes of arc ; and the vernier is divided into minutes and sixths, every sixth part of a minute being of course ten seconds of arc. Every fifth degree is numbered 5, 10, 15 and so on up to 160, or whatever number of degrees



THIS PAGE IS LOCKED TO FREE MEMBERS

Purchase full membership to immediately unlock this page

DELVE INTO FANTASY, MAGIC, MYTHOLOGY & FOLKLORE

**Forgotten Books'
Full Membership gives
access to 797,885 ancient
and modern, fiction and
non-fiction books.**

Continue

*Fair usage policy applies

the arc is two divisions to the left of five minutes, you would add $5' 20''$ to the angle on the arc. For example, suppose the arrow cuts between $27^\circ 20'$ and $27^\circ 30'$, that is to say that the angle is more than the former and less than the latter, and that the line on the vernier which coincides exactly with a line on the arc is $7' 20''$. Your angle is $27^\circ 20' + 7' 20''$, that is $27^\circ 27' 20''$.

It is not easy to explain this without a sextant, but if you will take one in your hand and shift the index bar to different angles, you will, with the help of the above explanation, find little difficulty, I think, in learning how to read the sextant.

Here are a few more cases :

(1) The arrow on the vernier coincides exactly with 20° on the arc.

The angle measured is $20^\circ 0' 0''$.

(2) The arrow on the vernier coincides exactly with the fourth division to the left of 49° on the arc.

The angle measured is $49^\circ 40' 0''$

(3) The arrow on the vernier lies between the 72° and the next division to its left, and the line on the vernier which coincides exactly with a line on the arc is the fifth division on the vernier to the left of $9'$

The arc gives you	$72^\circ 0'$
The vernier gives you	$9' 50''$
The angle is	$72^\circ 9' 50''$

These are all readings 'on the arc,' that is to the left of zero.

For certain purposes it is necessary for you to know how to read an angle 'off the arc,' that is to the right of zero. To do this you must note the number of divisions to the right instead of to the left on the arc, and if the arrow on the vernier coincides with a line on the arc, you have the angle. If the arrow on the vernier does

not coincide with a line on the arc, count from the left of the vernier till you come to a line coinciding with a line on the arc, and deduct from 10, so that 9 is one, 8 is two, and so on.

Suppose the arrow on the vernier cuts between the fourth and fifth divisions off the arc to the right of 1° , the angle lies between $1^\circ 40'$ and $1^\circ 50'$; and suppose that the line on the vernier which coincides exactly with a line of the arc is the first to the right of $2'$ on the vernier: deduct $2'$ from $10'$, which gives you $8'$, and one division to the right gives you $10''$. The angle of the arc is therefore $1^\circ 48' 10''$.

Practice alone can enable you to measure Altitudes and other angles with a sextant accurately, and whenever you have time and opportunity you should be constantly taking angles, both vertical and horizontal.

The Board of Trade Examiners will require you to know how to make the three following adjustments of a sextant. The first is to see that the Index Glass is perpendicular to the plane of the instrument. To do this you must place the vernier at about the centre of the arc, then holding the sextant face upwards with the arc away from you, look in the Index Glass and you will see the reflected image of the arc. If this is exactly in a line with the arc itself, which you can also see, the adjustment is good, and the Index Glass is perpendicular to the plane of the instrument, but if it is not you must make it so by means of a little screw at the back of the Index Glass.

The second is to make the Horizon Glass perpendicular to the plane of the instrument. Place the vernier at zero, and holding the sextant obliquely, look at the Horizon through the collar and the Horizon Glass. If the reflected image of the Horizon is exactly in a line with the Horizon the adjustment is perfect. But if they are not in a line

the Horizon Glass must be made perpendicular by means of the little screw at the back of it which is furthest from the frame of the sextant. This adjustment may also be made by the Sun in this way. Place the vernier at zero, and having interposed the necessary shades, screw in the inverting tube and look at the Sun through the Horizon Glass, then by means of the tangent screw make the reflected image of the Sun pass over the real Sun ; if they exactly cover one another when doing so the adjustment is correct.

The third adjustment is to make the Horizon Glass exactly parallel to the Index Glass when the vernier is at zero. Set the vernier exactly at zero. Screw in the inverting tube and look at the Horizon through the Horizon Glass. If it appears in one unbroken line the adjustment is perfect ; if not, the screw at the back of the Horizon Glass nearest to the frame of the sextant must be turned till the adjustment is made.

As a rule, if you possess a good instrument you will have little bother with the first and second adjustments—the makers take care that the sextant leaves their hands with the Index and Horizon Glasses accurately perpendicular to the plane of the instrument ; and if through an accident the sextant gets a blow, and is thereby put out of adjustment, it is best to send it to the maker to be put to rights.

Any error in the angle measured by the sextant due to imperfection in the third adjustment is called in books of instruction the ‘Index Error’ ; it is generally small, and in preference to eliminating it by means of the screw at the back of the Horizon Glass you should ascertain its amount and allow for it. You can do this by the Sun, or by a Star, or by the Horizon, by the following methods :



THIS PAGE IS LOCKED TO FREE MEMBERS

Purchase full membership to immediately unlock this page

SAVE \$3,999,994

Did you know we sell
paperback books too?

To buy our entire catalog
in paperback would cost
over \$4,000,000

Access it all now for
\$8.99/month

*Fair usage policy applies

Continue

and $15' 42''$ would be the Sun's Semi-Diameter on the day the observation for Index Error was taken if the observation were accurate.

To find the Index Error by a Star.—Screw in the inverting tube, set the vernier at zero, then look at a Star, and with the tangent screw cause the reflected image of the Star to coincide exactly with the Star as seen through the Horizon Glass. If the vernier is then at zero there is no Index Error. But if it is not, the angle on the sextant is the Index Error, which if it is 'off' the arc is additive, if 'on' the arc subtractive.

To find the Index Error by the Horizon.—Screw in a tube, set the vernier at zero, and look at the Horizon, holding the sextant obliquely. If the Horizon presents one unbroken line there is no Index Error. If the reflected Horizon is above or below the real Horizon, bring them into one unbroken line with the tangent screw, and the angle on the sextant is the Index Error, which is named in the same way as when it is taken by a Star or by the Sun.

The last method of finding the Index Error—namely, by the Horizon—is the least reliable, and cannot be depended upon. The first method, by the Sun, is the best, and a very good result can be got by a bright Star. The Moon is very seldom of any use for this purpose, because, except at full Moon, her disc is not perfect; and the Planets are not so reliable as the Stars, because they have sensible Semi-Diameters.

The Index Error of a sextant should frequently be determined, more particularly after observing a Lunar Distance, which requires such great nicety that every second makes a difference.

Another error, known as collimation error, is due to the line of sight or axis of the tube not being parallel to the

plane of the instrument. You can test this in the following way. Screw in an inverting tube, in which are two wires parallel to each other, and turn the tube till the wires are parallel to the plane of the instrument. Then measure with the sextant an angular distance of not less than 90° between two Heavenly Bodies, making a perfect contact with both objects on with one of the wires ; then by moving the sextant slightly bring them on to the other wire : if the contact remains perfect there is no collimation error ; if the contact is broken there is collimation error, and you had better send the instrument to the maker for adjustment. If that is not possible you can make the adjustment yourself by tightening the screw of that part of the collar nearest to the instrument, and loosening the screw on that part of the collar furthest from the instrument, or *vice versâ* ; but the operation is a delicate one, and should be entrusted to professional hands.

A good modern sextant is as near perfection as human ingenuity can make it ; but there is almost always a small error in the measurement of large angles caused by what is called centreing error. It is due to the fact that the centre of the arc and the centre of the index bar are not absolutely identical. At the Kew Observatory sextants are tested, and certificates issued giving the instrument error. The error due to this cause should never, even in the largest angles, amount to $1'$ in a good instrument.

The Theory of the Sextant

You are not required by the Board of Trade to explain the theory of the sextant, but I give it here, as it may be interesting to you.

The following diagram will explain better than any amount of verbiage :

FIG. 43

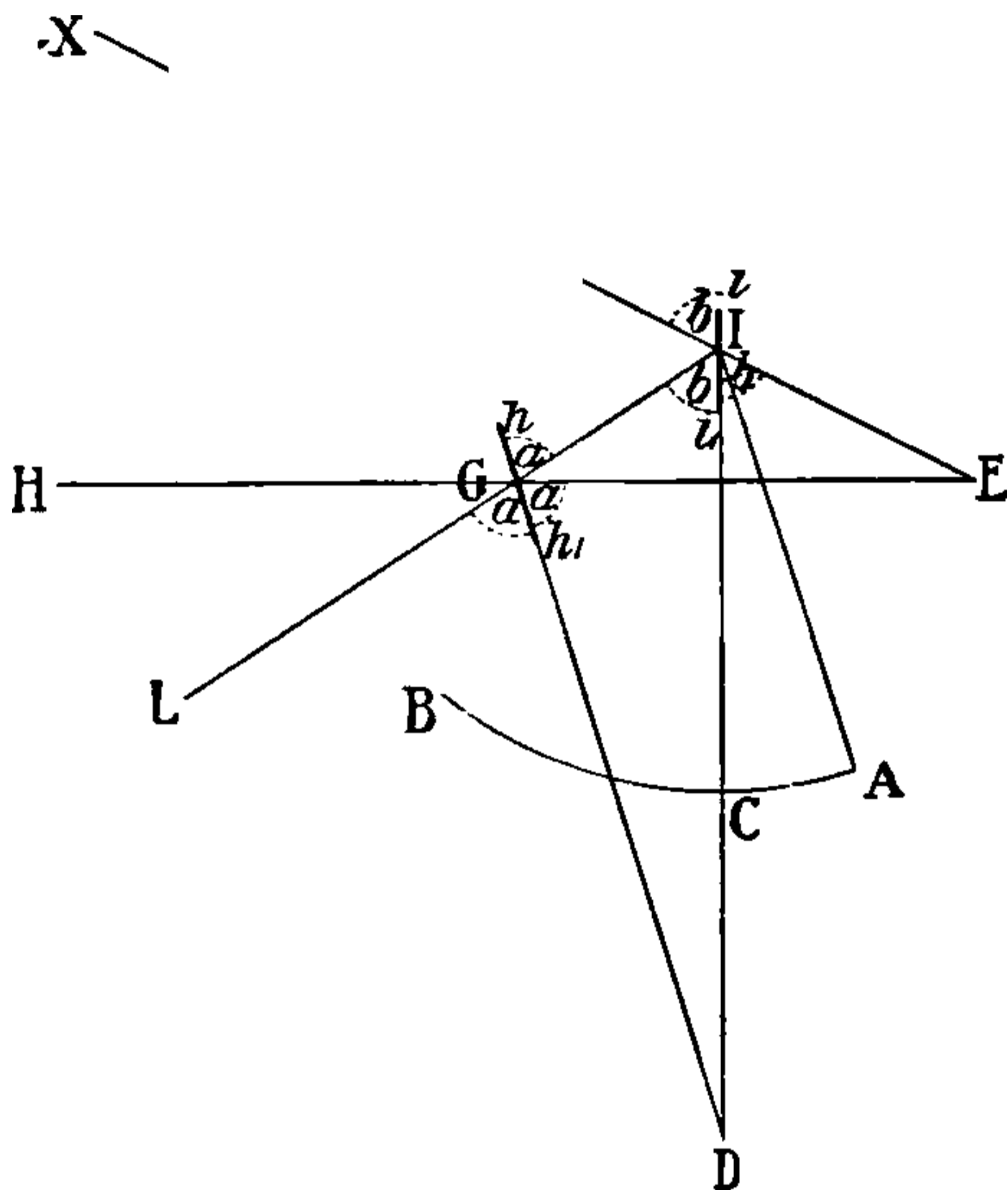

Let AB be the arc of the sextant whose centre is I . Let zero be at A . Let ii_1 be the Index Glass, hh_1 the Horizon Glass, and IC the radius bar. If a ray of light comes from a Heavenly Body at X in the direction XE , it will impinge upon the Index Glass at I and will be reflected by it at an angle equal to that at which it strikes it in the direction of the line IL . Being intercepted by the Horizon Glass, it is again reflected in the direction of the line GE . Let H be the Horizon. If the eye of an observer be at E , it is evident that the reflection of the Heavenly Body as reflected by the mirror portion of the Horizon Glass, and the Horizon, as seen through the transparent part of the Horizon Glass, will appear to be in one. Draw GD parallel to IA , A being the zero on the arc. Then the arc AC measured by the angle AIC is one half the angle XEH , which is the Altitude of our



THIS PAGE IS LOCKED TO FREE MEMBERS

Purchase full membership to immediately unlock this page

DELVE INTO FANTASY, MAGIC, MYTHOLOGY & FOLKLORE

**Forgotten Books'
Full Membership gives
access to 797,885 ancient
and modern, fiction and
non-fiction books.**

Continue

*Fair usage policy applies



The Chronometer

This invaluable instrument is simply a wonderfully accurate watch, whose balance wheel is so constructed that changes of temperature do not affect, or only very slightly affect, its times of oscillation. This compensation is achieved by the following means: the rim of the balance wheel is composed of two metals, the outer part being made of brass, and the inner part of steel, and it is cut into two nearly semicircular halves. One end of each of these halves is fastened to the opposite end of a stout metal diameter of the wheel. Weights are fastened to the outside of the two semicircles in such positions as to produce as nearly as possible a perfectly equal period of vibration at different temperatures on the following principle: When the temperature rises, the two halves of the rim, supported as they are on the two ends of one diameter, curve inwards because their outer parts are made of brass, which expands more than the inner parts, which are made of steel; and thus the attached weights are carried inwards. The whole mass of the wheel, composed of axle, diameter, rims, and attached weights, becomes less in diameter under a rise of temperature, and consequently the spring has less work to do in keeping up the vibration at the same speed; but the increase of speed is balanced by the fact that under a rise of temperature the hair spring loses its elasticity slightly, and the result consequently is that the time of oscillation of the balance wheel does not vary.

On the other hand, as the hair spring becomes more elastic and has more resisting force under a fall of temperature, the vibrations of the wheel would be retarded were it not that the expansion of the wheel and

carrying outward of the attached weights give the spring more work to do.

The first chronometer was made by John Harrison, and it was his life-work, occupying him some fifty years ; for the invention he received 20,000*l.* from the British Government in 1765. He died in 1776.

The Artificial Horizon

(An Extra Master must be able to use the Artificial Horizon.)

An artificial Horizon is simply a trough containing any fluid. Quicksilver is, however, generally used, because it gives the best reflecting surface. The principle on which the artificial Horizon is founded is the well-known law of optics, that the angle at which a ray of light strikes a reflecting surface is the same as that at which it is reflected from it ; in other words, that the angle of incidence is equal to the angle of reflection.

FIG. 44

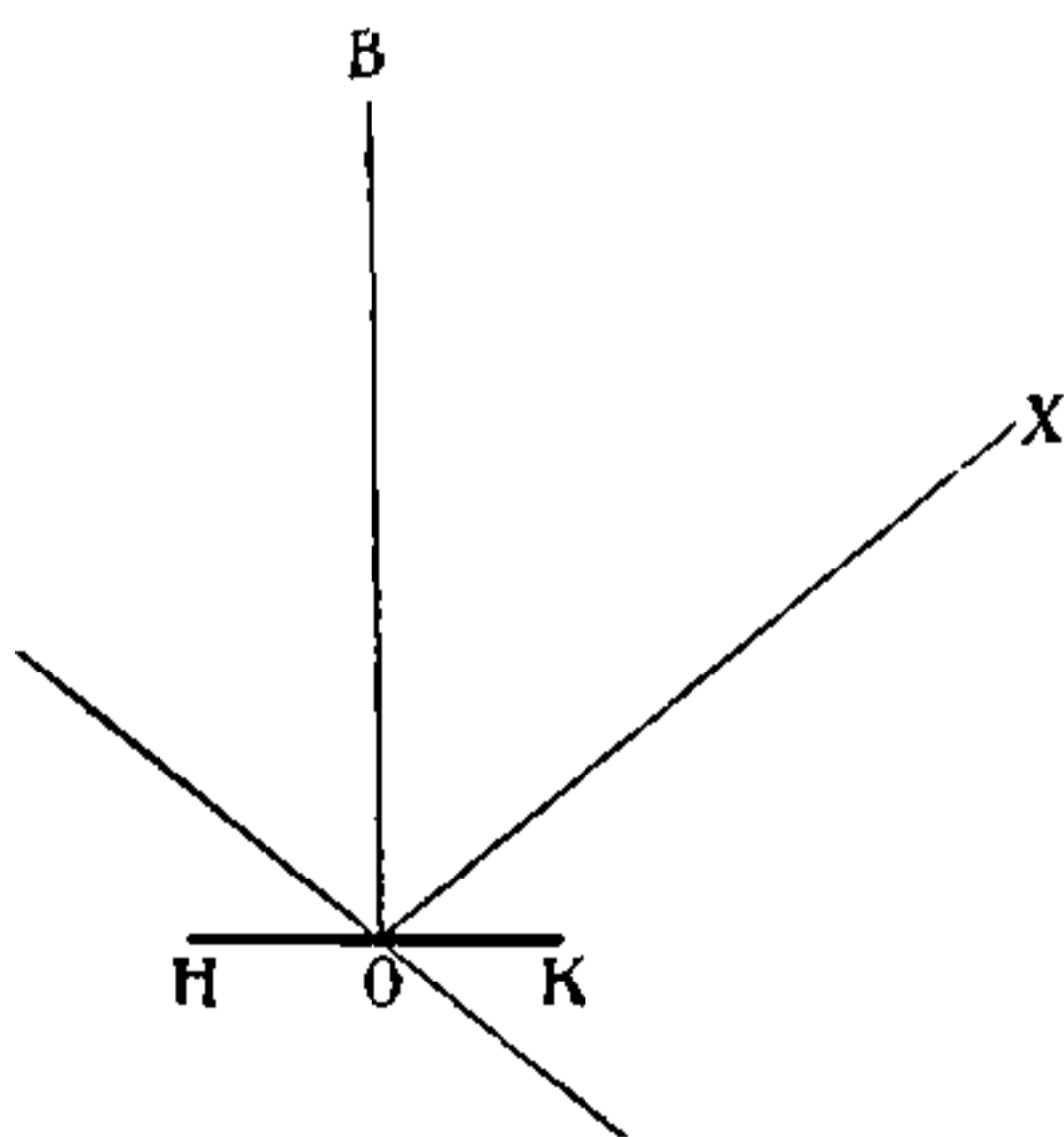

In the diagram let HK represent the surface of the mercury, which is of course horizontal ; XO a ray of light from the body X ; then BOX is the angle of incidence and BOA is the angle of reflection. It follows that their

complements, the angles $\Sigma O K$ and $A O H$, are also equal. To an observer the reflected image of Σ would appear at Υ , and the angle $\Sigma O \Upsilon$ equals twice the angle $\Sigma O K$, because the angle $\Sigma O K$ equals the angle $A O H$, and the angle $A O H$ equals the angle $K O \Upsilon$ (by Euclid), it being opposite to it, and therefore the angle $\Sigma O K$ equals the angle $K O \Upsilon$; therefore the angle $\Sigma O \Upsilon$ equals twice $\Sigma O K$. Now $\Sigma O K$ is the angular distance the body is above the Horizon, that is, it is its Altitude.

FIG. 44

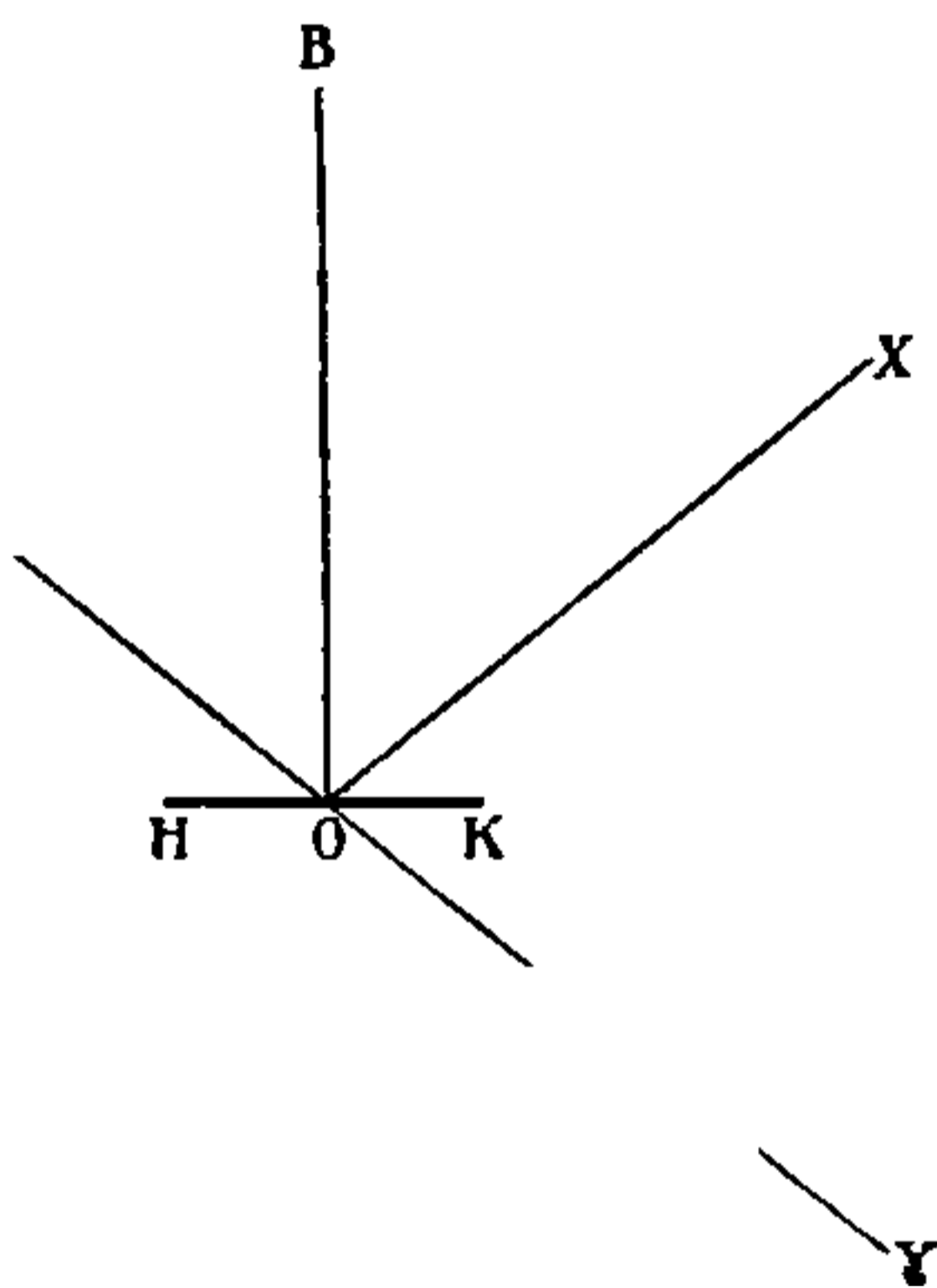

Remember, therefore, that when you measure the angular distance between the Sun, or any other Heavenly Body, and its reflection in the quicksilver, the angle you have taken is twice the Altitude; and remember also that there is no Dip to be allowed for. Index Error is to be allowed for on the whole angle before halving it to get the observed Altitude.

English's Star-finder

This instrument is of great use to the navigator in finding and identifying Stars. Its description is given at the end of the next chapter, as its use could not be properly appreciated till you are acquainted with the movements of the Heavenly Bodies.



THIS PAGE IS LOCKED TO FREE MEMBERS

Purchase full membership to immediately unlock this page

SAVE \$3,999,994

Did you know we sell
paperback books too?

To buy our entire catalog
in paperback would cost
over \$4,000,000

Access it all now for
\$8.99/month

*Fair usage policy applies

Continue

Heavenly Bodies only as indicating their Bearing from the observer, or the Bearing of one Body from another. Though North and South may be called fixed and definite positions, East and West can in astronomy be used merely as arbitrary expressions to indicate the direction in which a Heavenly Body moves in reference to some other Body; usually the Sun or the Earth.

To ascertain whether the movement of a Body is Easterly or as it is called Direct, or is Westerly, or as it is called Retrograde, imagine yourself facing North and looking at the orbit of the Body edgewise, and assume that the Body starts from where you are. If the Body moves off towards your right, its movement is Easterly or Direct ; if it moves off to your left, it is Westerly or Retrograde. Or put it this way : Easterly motion is contrary to the direction in which the hands of a watch move when held face uppermost ; Westerly motion is in the same direction as that in which the hands of a watch move.

The Earth rotates on her axis from left to right, that is from West to East ; her rotatory movement is Easterly. To an observer above the North Pole looking down upon her, she would be rotating in a direction contrary to that in which the hands of a watch move.

The Earth moves round the Sun in her orbit in an Easterly direction, also contrary to the direction in which the hands of a watch move. All the other planets revolve round the Sun in the same direction. The Moon revolves round the Earth in the same direction, and rotates on her axis from left to right, or from West to East, in the same direction as the Earth does. If the observer were looking South, the movement of the Earth would appear to be from right to left ; for instance, if you face the Sun when you are North of it, it rises to the left, and sets to the

right of you. If the observer were suspended above the South instead of above the North Pole, the movements of the Heavenly Bodies would be with instead of against the hands of a clock. In speaking therefore of Heavenly Bodies moving from left to right, or right to left, you must remember that the expressions are used arbitrarily, to signify directions in which bodies move supposing you to be situated on the Globe facing North. East and West are not affected by the direction in which you are facing, but are also arbitrary expressions. The best way of understanding what Easterly or Westerly means is to remember that Easterly is contrary to the movement of the hands of a watch, and Westerly is with it, as seen from above the North Pole.

For all purposes of nautical astronomy the centre of the Earth is considered to be a fixed immovable point, and all angles, distances, positions, movements, &c. &c. are referred to it as a fixed point. For all purposes of calculating Polar or Hour Angles the Meridian of the observer is considered to be fixed and the Heavenly Body is assumed to be moving.

The Earth revolves on its axis once in 24 hours, turning from W to E, thus giving the Heavenly Bodies the appearance of travelling from East to West, rising in the East and setting in the West.

The Earth travels round the Sun ; it makes a complete revolution of the Sun once in a year, moving in an Easterly direction. The path of the Earth does not form a circle with the Sun in the centre, but an ellipse, with the Sun in one of the foci. The Earth is consequently much nearer the Sun at some seasons than at others. In Northern Latitudes it approaches the Sun nearest in midwinter, and its furthest point is reached in midsummer.

The annual revolution of the Earth round the Sun causes

the Sun to *appear* to move in an Easterly direction among the stars. This apparent path of the Sun in the heavens is called the Ecliptic.

The Earth's axis does not stand upright, that is to say the axis of the Earth is not at right angles to the plane of the Ecliptic. It is inclined to it at an angle of about $23^{\circ} 28'$. A consequence of this arrangement is that, as the Earth swings along her path round the Sun, the Poles are at different times inclined at different angles towards the Sun—a larger portion of the Northern Hemisphere, for instance, is exposed to the Sun's rays at one time of the year than at another. In other words the Sun *appears* to move to the Northward and to the Southward during the year. On March 20th the Vernal Equinox occurs; the Sun is then right above the Equator, shining vertically down; the dividing line between light and shade passes through both Poles, and there is equal day and night all over the Globe. The Sun then appears to move Northward; it rises higher and higher, and our days in the Northern Hemisphere get longer and longer until June 21st, when the longest day occurs. The Sun is then vertically over the Tropic of Cancer in $23\frac{1}{2}^{\circ}$ N, and the Arctic Circle, that is a circle extending to $23\frac{1}{2}^{\circ}$ round the North Pole, is constantly illuminated. The Sun then appears to retrace its steps and moves Southward, until on September 22 it is again directly over the Equator, and the Autumnal Equinox occurs. The Sun continues its Southward Course until December 21st, when it is over the Tropic of Capricorn in $23\frac{1}{2}^{\circ}$ South, and the shortest day occurs in the Northern Hemisphere. Then the Sun turns, and proceeding to come North again, repeats the process described.

The diagram shows how this occurs. The Sun is shown in the centre and the Earth is drawn in four



THIS PAGE IS LOCKED TO FREE MEMBERS

Purchase full membership to immediately unlock this page

DELVE INTO FANTASY, MAGIC, MYTHOLOGY & FOLKLORE

**Forgotten Books'
Full Membership gives
access to 797,885 ancient
and modern, fiction and
non-fiction books.**

Continue

*Fair usage policy applies

A Meridian is a Great Circle passing through both Poles of the Earth. The Meridian of an observer is a Great Circle passing through the position of the observer and both Poles.

Longitude is measured along the Equator from the Meridian of Greenwich, which is Zero (0). Longitude is not counted right round the circles from 0 at Greenwich to 360 at Greenwich, but from 0 at Greenwich to 180 degrees East, and from 0 at Greenwich to 180 degrees West. The position of a ship on any spot on the Globe can be fixed by finding its Latitude, that is, its angular distance North or South of the Equator, measured along a Meridian, and its Longitude, that is, its angular distance measured along the Equator East or West from the Meridian of Greenwich.

As the axis of the Earth passing through the Poles, prolonged indefinitely, forms the Celestial Poles, so the Great Circle—the Equator—prolonged indefinitely, forms the Celestial Equator. This is also called the Equinoctial.

The Equinoctial and the Ecliptic (the apparent path of the Sun) are not in the same plane. They are inclined to each other at an angle of $23^{\circ} 28'$. They must therefore cut each other at two places. They do so at what is called the First Point of Aries and at the First Point of Libra. These are called the Equinoctial Points, because when the Sun is in either of them day and night are equal all over the Globe.

Just as the position of a terrestrial place is determined by its Latitude and Longitude, so is the position of a Heavenly Body determined by its Declination and Right Ascension.

Declination is measured along a celestial Meridian North or South of the Equinoctial, just as Latitude is measured

along a terrestrial Meridian North or South of the Equator.

Right Ascension is measured along the Equinoctial, just as Longitude is measured along the Equator, but starting at 0 from the First Point of Aries it is counted right round the whole circle Easterly, that is against the hands of a clock, for 360 degrees back again to the First Point of Aries.

Declination is expressed in arc ; in degrees, minutes, and seconds of arc. Right Ascension is usually expressed in time ; in hours, minutes, seconds of time, for convenience sake. For the same reason Longitude is first determined and expressed in time.

As the Sun appears to move round the Earth in 24 hours, we say naturally that he makes a complete revolution in 24 hours, half a revolution in 12 hours, and a quarter of a revolution in 6 hours, and so on. At apparent noon the Sun is on the Meridian of the observer, it is 0 hours : the Sun makes no angle at the Pole. In 6 hours the Sun has made a Westerly angle of 6 hours at the Pole ; 6 hours later he makes a 12 hours' Westerly angle, and it is midnight ; he is exactly opposite where he was at noon. 6 hours later he is making a Westerly angle at the Pole of 18 hours, or what is the same thing, an Easterly angle of 6 hours, and after 6 more hours he is back again at the Meridian ; he makes no angle at the Pole, and it is apparent noon.

It is plain, therefore, that ' Apparent Time ' is the angle at the Pole between the Meridian passing through the Sun, and the Meridian passing through a place ; and this polar angle can be expressed in terms of arc or of time, as you please, but it is more conveniently expressed in time. The position of the Sun in respect of the Meridian of Greenwich, which is the starting-point from which Longitude is counted, is the angle at the Pole

between the Meridian of Greenwich and the Meridian passing through the Sun at any moment. It is more convenient to speak of the Sun as so many hours, minutes, seconds of time East or West of Greenwich, than to speak of him as so many degrees, minutes, seconds of arc East or West of Greenwich. In finding Longitude you could use Apparent Time (the angle made by the Apparent Sun), if you compared it with Apparent Time at Greenwich ; but you use Mean Time (the angle made by the Mean Sun) and compare that with Mean Time at Greenwich—because chronometers keep Mean Time. The difference between the angle made at the Pole by the Meridian passing through the Mean Sun and the Meridian passing through the observer, and the angle made at the Pole by the Meridian passing through the Mean Sun and the Meridian of Greenwich is Longitude in Time. When you come to fix your position on the Globe, Longitude in Time has to be converted into Longitude in Arc.

In the same way the position of a Heavenly Body in respect to the First Point of Aries, which is the starting point from which Right Ascension is counted, is the angle at the Celestial Pole between the Meridian of the Body and the Meridian of the First Point of Aries, and it is best expressed in terms of time. Just as the position of any place on the Globe is fixed by its Latitude and Longitude, so is the position of a Heavenly Body fixed by its Declination and Right Ascension.

The positions of the fixed stars vary but very slightly. Their distance from us is so enormous that their Right Ascension and Declination are not affected by the changing position of the Earth in her orbit. The Right Ascension and Declination of a star do vary a little, they change slightly owing principally to the fact that the place in the sky to which the North Pole points is slowly changing.



THIS PAGE IS LOCKED TO FREE MEMBERS

Purchase full membership to immediately unlock this page

SAVE \$3,999,994

Did you know we sell
paperback books too?

To buy our entire catalog
in paperback would cost
over \$4,000,000

Access it all now for
\$8.99/month

*Fair usage policy applies

Continue

us, for if the Solar and the Sidereal day were of equal length, some constellations would be permanently invisible; so perhaps the original arrangement is after all the best.

Some stars never set. A star whose Declination is of the same name as the Latitude, and is greater than the Colatitude, is *always* above the Horizon of a person on that Latitude. Stars whose Declinations are of the same name as Latitude, but less than the Colatitude, and stars whose Declinations are of opposite name to the Latitude, but less than the Colatitude, are above the Horizon of a spectator on that Latitude during some period of the 24 hours. Stars whose Declinations are of the opposite name to the Latitude, and greater than the Colatitude, never rise above the Horizon of a spectator on that Latitude.

If you change your Latitude you will of course correspondingly change the Altitudes of the stars, Southern stars sinking lower till they disappear, and Northern stars rising higher and higher as you move North, and *vice versâ*.

Planets are not as satisfactory as fixed stars to deal with, on account of their rapid motion; and the motion of the Moon is so much more rapid than that of the planets that she is a difficult and obnoxious body to observe.

The Earth is a planet, and all the planets move round the Sun in various orbits, but all in the same direction, Easterly.

Venus and Mercury are called inferior planets because they are nearer the Sun than we are; their orbits are consequently considerably smaller than the orbit of the Earth. Owing to this fact they always appear pretty close to the Sun as viewed from the Earth, and are visible only about sunrise or sunset. Mercury and Venus are morning or evening stars.

Mercury is too near the Sun to be of value for navigational purposes ; but Venus, from her brilliancy and from the fact that she is pretty nearly East or West in the mornings or evenings—in other words is in the best position at the best time of day for observational purposes—is most useful to the mariner.

Mars, Jupiter, and Saturn are called Superior planets.

Their orbits lie outside our orbit, and consequently they can occupy any and every position in respect to the Sun. As all the planets are moving round the Sun, they change their position in the heavens relatively to the fixed stars, consequently their Right Ascension changes, and sometimes rapidly. As they all move, each in its own particular orbit, and the planes of their orbits are inclined at various angles to the Equinoctial, their Declinations also change.

As all the planets, the Earth included, move round the Sun in the same direction, they may overtake and pass each other going in the same direction, but they can never approach from opposite directions and pass each other.

As the planets, the Earth included, are constantly passing each other, and as their relative positions change according to their position on their respective orbits, it follows that, as viewed from the Earth, planets sometimes appear to have a retrograde movement, and to describe curious spirals and curves.

The Moon revolves on her own axis from West to East, as does the Earth. She revolves round the Earth in an Easterly direction, making a complete revolution in the sky in 27 days 7 hours 43 minutes ; and, hanging on to us, she makes a complete revolution round the Sun in a year.

The orbit of the Moon is very nearly in the same

plane as that of the Ecliptic, or orbit of the Earth. The Moon is full when she is opposite to the Sun, in other words when the Earth is between her and the Sun. In the summer time in Northern Latitudes the North Pole of the Earth is inclined towards the Sun, therefore it is inclined away from the Moon when she is full; in other words, the Moon has then a large Southern Declination. The opposite of this occurs in the winter season. The consequence of this is that the full Moon rides high in the heavens and remains a long time above the Horizon during our winter months, and is comparatively low in the heavens and remains comparatively a short time above the Horizon during our summer months.

When the Moon is directly between the Earth and the Sun, her illuminated face or side is away from the Earth, and her dark face towards the Earth. She is invisible, and it is new Moon. As she clears the Earth as it were, a larger and larger portion of her illuminated surface becomes visible from the Earth, until she is exactly opposite the Sun, when the whole of her illuminated face is towards the Earth, and it is full Moon. As she proceeds on her course, she shows less and less of her illuminated face to the Earth, until she becomes invisible, and it is new Moon again. If the Moon waltzed round us exactly in the plane of our orbit round the Sun, she would, when full, be in the Earth's shadow, and invisible, and she would when new intercept the Sun's light, and the Sun would be invisible; but the plane of the orbit of the Moon being inclined to the plane of the orbit of the Earth at an angle of about 5° , the Moon is nearly always above or below the plane of the Earth's orbit, when she is full or new. If she happens to be in the plane of the Earth's orbit when full, there is an eclipse of the Moon. If she happens to be in the plane of the Earth's orbit when she



THIS PAGE IS LOCKED TO FREE MEMBERS

Purchase full membership to immediately unlock this page

DELVE INTO FANTASY, MAGIC, MYTHOLOGY & FOLKLORE

Forgotten Books'
Full Membership gives
access to 797,885 ancient
and modern, fiction and
non-fiction books.

Continue

*Fair usage policy applies

for a gradually increasing length of time, as she moves North, and for a gradually decreasing length of time as she moves South; but her movement along her orbit causes her to rise later and later every day. The effect of her movement in Declination never overcomes the effect of her orbital movement—the Moon never rises earlier on one day than she did on the day before; but the effects of the two movements may nearly balance each other. In September at full Moon the Moon is coming North so rapidly that her increasing Declination almost makes up for her movement in her orbit. She, so to speak, rises later on account of her proper motion round the Earth, and rises earlier on account of her apparent motion in Declination. The consequence is, that the Moon rises about the same time for three or four days in succession, and we have what is called a ‘Harvest Moon.’

In dealing with the fixed stars, with the exception of the Sun, an observer need not bother himself about correcting Right Ascension and Declination; he can take these elements straight out of the Nautical Almanac. In dealing with the planets he must bother himself a little—their Right Ascensions and Declinations may require correcting. But if he tackles the Moon he must bother himself a good deal, for her Right Ascension and Declination must be very accurately corrected. The Sun, though a fixed star, is so close to us that his Declination, Right Ascension, and also Semi-Diameter, and our Horizontal Parallax require correction.

In conclusion be it always remembered that all corrections must be made for the Greenwich time at which your sights were taken.

Right Ascensions, Declinations, Semi-Diameters, Horizontal Parallax, Times of Transit, and everything else to do with Heavenly Bodies, Equation of Time in-

cluded, are calculated and given you in the Nautical Almanac for *Greenwich Noon*. Therefore the first thing to do in working any problem, from observation of a Heavenly Body, is to find out what time it was at *Greenwich* when your sights were taken ; and the next step is to correct the Right Ascension, Declination, or whatever it may be that requires correction, of the body observed, for the change that has taken place in the interval of time elapsing between the Greenwich date of your observation and the Greenwich noon. *Greenwich* is all you have got to think about.

English's Globe Star-finder

To anyone not thoroughly acquainted with the Stars, this little instrument is invaluable, and it is very useful also to those who know the aspect of the heavens well. It enables you to find the places of all the Stars from the first to the third magnitude, at any time, and viewed from any place on the Globe, with sufficient exactitude for all practical purposes. By means of it you can identify any Star of which you have snapped the Altitude in cloudy weather. You can see at a glance those Bodies which are most suitable for double chronometer work at any time you desire, and you can tell by inspection when any Heavenly Body will rise or set, or be on the Prime Vertical, &c., &c. For instructing yourself or others it is much to be preferred to Star charts.

The Star-finder consists of an ordinary celestial globe, on which are marked all the Stars of the first, second, and third magnitudes. It is fitted with a brass meridian having degrees of Declination marked on it, and also with movable Vertical Circles marked to degrees of Altitude. Right Ascension is read on the Equinoctial of the globe,

and the Horizon is marked in degrees of Azimuth. The method of using it is simple.

To adjust the instrument for Latitude.—Turn the brass meridian, which is graduated in degrees from 0° at the Equator to 90° at either Pole, round until the degree of Latitude of the observer is directly under the Zenith, which is the point of intersection of the Altitude Circles; or until the degree of Colatitude is on the Horizon; the North Pole being elevated in North Latitude, and the South Pole in South Latitude.

To adjust the instrument for time.—The Equinoctial is marked in time from the First Point of Aries (which is XXIV hours or 0 hours) to the Eastward right round the globe.

The adjustment is made by turning the globe round on its axis till the hours and minutes of the Sidereal Time of observation is brought exactly under the brass meridian.

Sidereal Time for this purpose is found by either of the following formulas:—

$$(1) \text{ Sidereal Time (R. A. Mer)} = \text{R.A.M.}\odot + \text{M.T.S.}$$

$$(2) \text{ Sidereal Time (R. A. Mer)} = \text{R.A.A.}\odot + \text{A.T.S.}$$

The instrument being adjusted for Latitude and Time, all the Stars represented on the globe are in their correct positions. Their Altitudes and Azimuths can be ascertained by turning the Altitude Circles round in Azimuth till the graduated leg is immediately over any desired Star, when its Altitude can be read on the graduated Altitude Circle above it, and its Azimuth on the Horizon where the same leg cuts it. The globe can be used also to find the position of the Sun, Moon, and Planets.

To find the position of the Sun.—Take from the Nautical Almanac the Right Ascension and Declination of the Sun at the desired time in the usual manner. Turn



THIS PAGE IS LOCKED TO FREE MEMBERS

Purchase full membership to immediately unlock this page

SAVE \$3,999,994

Did you know we sell
paperback books too?

To buy our entire catalog
in paperback would cost
over \$4,000,000

Access it all now for
\$8.99/month

*Fair usage policy applies

Continue

will have a certain Altitude and its Hour Angle at that time.

(1) Set the globe for Latitude.

(2) Turn the globe round on its axis till the given Body is under the degree of Altitude as shown by one of the Circles of Altitude.

Then the Sidereal Time less the Right Ascension of the Heavenly Body is the Hour Angle of the Body ; and the Sidereal Time less Right Ascension of the Mean Sun is Mean Time at Ship.

The above are a few of the uses to which the Starfinder may be put ; but perhaps its greatest advantage is in connection with twilight Stars and double chronometer work.

In using the globe for this purpose the Moon's position should always be found, as she might happen to be in the way of one of the Stars you wish to observe.

Also the Planets should not be neglected if above the Horizon at a suitable time, which can be easily ascertained by glancing at the time of their Meridian Passage in the Nautical Almanac.

To determine what Heavenly Bodies can be advantageously observed for the purpose of double chronometer work at twilight.

(1). Find the Sidereal Time of observation (about one hour before sunrise or one hour after sunset).

(2). Set the globe to Latitude and Time.

(3). Turn the Altitude Circles round till two adjacent legs rest as nearly as possible over two Stars having suitable Altitudes. Read off their Altitudes and Azimuths.

Then put the Altitude on the sextant, and at the time fixed upon look through the sextant at the Horizon on the Bearing ascertained, and the Star will be seen.

If three Stars (I mean by *Stars* Moon and Planets also if in suitable positions), two nearly East and West and one nearly North or South, are visible, excellent results can be obtained; the East and West Stars check one another for Longitude, and the South or North Star gives a capital Latitude.

In my humble opinion twilight observations of Stars, whereby a definite position can be obtained—not vitiated by an incorrect run, as is the case too often with forenoon and afternoon sights—are far and away the best method of determining a ship's position, and for this purpose English's Star-finder is certainly very useful.

CHAPTER XII

LATITUDE BY A MERIDIAN ALTITUDE OF THE SUN

IN order to solve any problem certain facts and positions must be known. In the 'Sailings' you find an unknown Latitude and Longitude from a known Course and Distance, or you find an unknown Course and Distance from a known Difference of Latitude and Longitude, and so on. You must have something definite to start with. Well, in working an observation for Latitude you have always two things with you from which you cannot possibly divest yourself, namely, the Horizon and the Zenith. With these fixed facts and the Declination, which you can easily discover in the Nautical Almanac, you can find your Latitude by a Meridian Altitude of the Sun.

The best way of explaining the problem is by the help of diagrams. Diagrams and Figures are said to be drawn upon a certain 'Plane.' The two planes we have to deal with at present are the plane of the Meridian and the plane of the Horizon. To understand a figure drawn on the plane of the Meridian, imagine yourself looking towards the centre of a Great Circle standing vertically over against you. If studying a figure drawn on the plane of the Horizon imagine yourself looking down upon a Great Circle spread out horizontally below you.

To ascertain Latitude by observation of the Meridian



THIS PAGE IS LOCKED TO FREE MEMBERS

Purchase full membership to immediately unlock this page

DELVE INTO FANTASY, MAGIC, MYTHOLOGY & FOLKLORE

Forgotten Books'
Full Membership gives
access to 797,885 ancient
and modern, fiction and
non-fiction books.

Continue

*Fair usage policy applies

the Sun at Noon, and is, of course, the highest Altitude to which it attains.

The Altitude of the Sun's lower or upper rim, or as it is called, 'limb,' above the Visible Horizon, is measured with a sextant, and noted down. But that is by no means the True Altitude. The True Altitude is the angle subtended at the centre of the Earth between the centre of the Sun and the Rational Horizon.

What is the Rational Horizon, and how is it derived from the Visible Horizon?

The *Visible* Horizon requires but little explanation; it is the circle bounding our vision at sea.

The *Sensible* Horizon is the plane of a circle perpendicular to a line drawn from the Zenith to the observer, and touching the surface of the Globe at the point on which he is situated.

The *Rational* Horizon is a Great Circle, whose plane passes through the centre of the Globe, and is parallel to the plane of the Sensible Horizon.

Now for the various corrections to be made to the Altitude of the Sun's Lower or Upper Limb as observed with the sextant. The first correction is for Index Error, if any exists: the Index Error, if plus, is to be added to the Observed Altitude; if the error is minus it is to be taken from the Observed Altitude.

After allowance has been made for Index Error the next correction is for *Dip*.

The Observed Altitude of the Sun is its angular distance above the *Visible* Horizon, and as the extent of the Visible Horizon increases according to the height of the observer above sea level, the first correction of Observed Altitude consists in a reduction of Altitude proportionate to the depression of the Visible Horizon due to the height of eye above sea level. This is called the 'Dip.'

In diagram No. 46 let $A B$ be an observer on the surface of the Earth, whose centre is O ; let x be a Heavenly Body, and L the Visible Horizon; then the angle $x B L$ is the Altitude of x above the Visible Horizon, and $x A H$ its Altitude above the Sensible Horizon at H ; the difference between these two angles is the *Dip*. The height of the observer $A B$ is so utterly insignificant in comparison with

FIG. 46

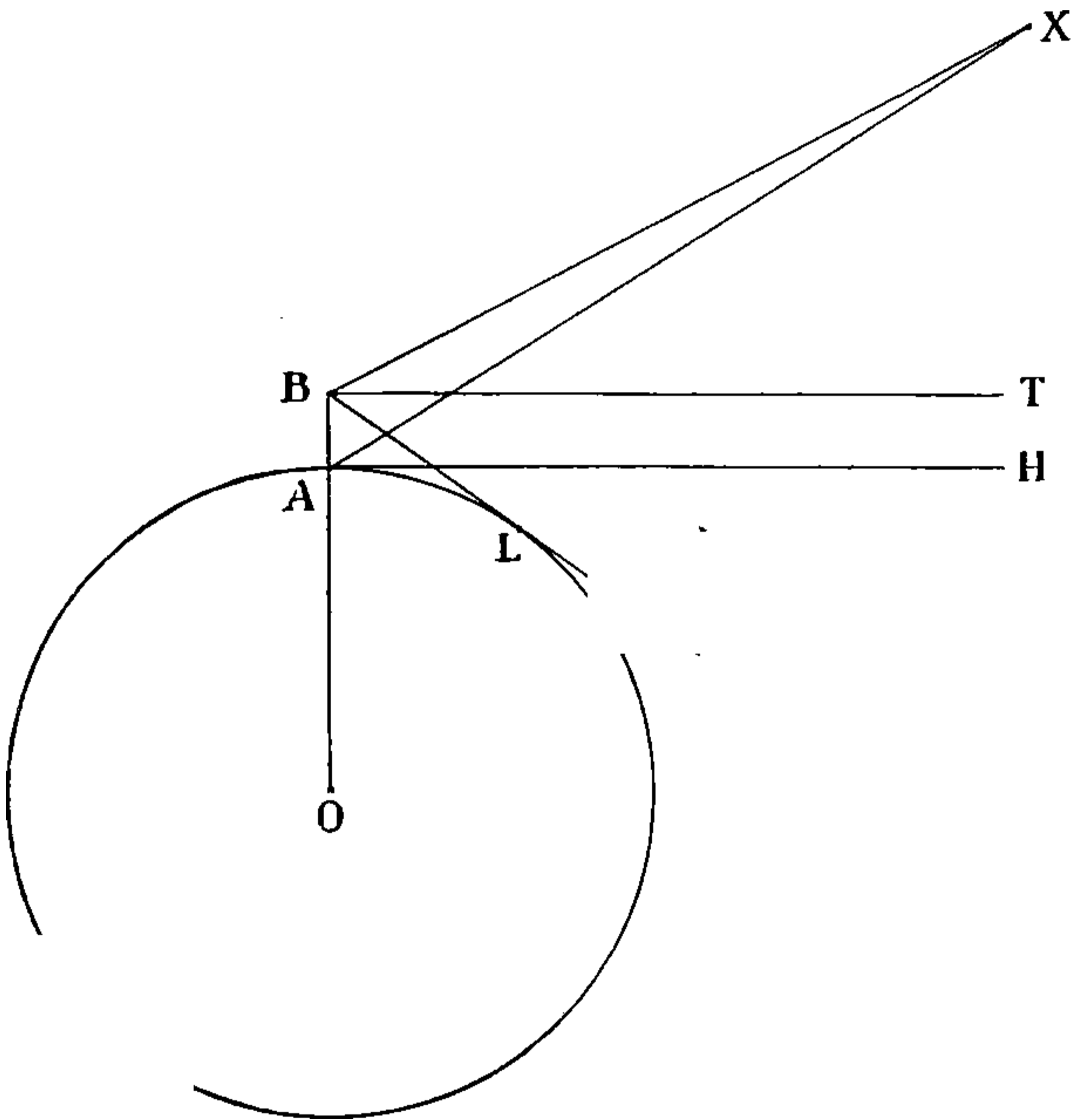

the distance of any Heavenly Body, that $A X$ may be considered to be parallel to $B X$, and the angle $x B T$ equal to the angle $x A H$. But the *Dip* equals the difference between the angles $x B L$ and $x A H$, and as $x A H$ and $x B T$ are practically equal, it is the difference between the angles $x B L$ and $x B T$, namely the angle $T B L$; $T B L$ therefore is the *Dip*.

The Dip is always to be *deducted* from the Observed Altitude, and the result gives us the Altitude of the Sun above the *Sensible* Horizon.

But we have observed one of the Limbs of the Sun, not the centre, and therefore the Semi-Diameter of the Sun must be allowed for. If the Upper Limb is taken, the Semi-Diameter must be subtracted. If the Lower Limb is observed, as is always done except in very rare cases, the Semi-Diameter must be added. The Semi-Diameter will be found for every day of the year on p. II. of each month in the Nautical Almanac.

FIG. 47

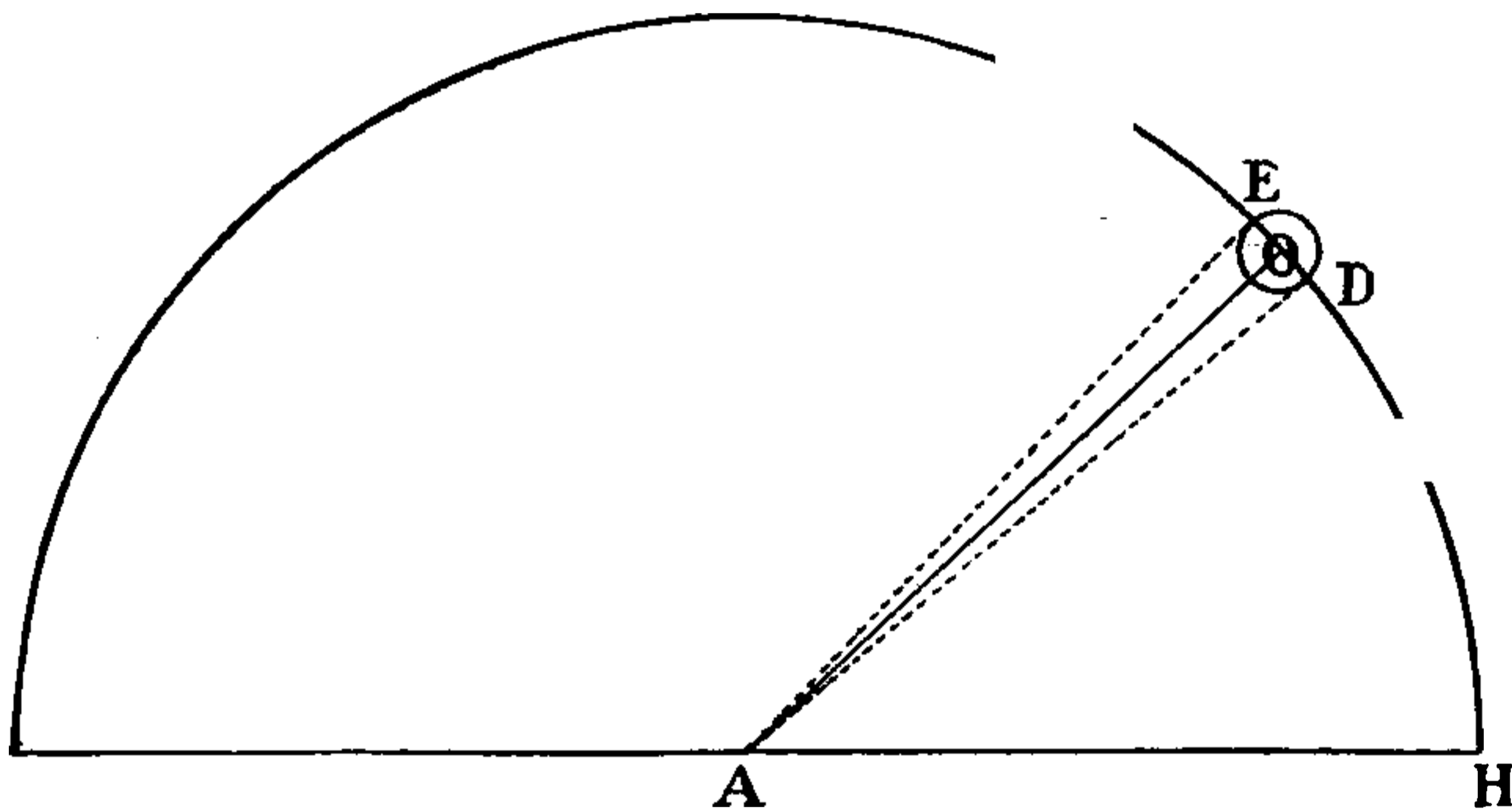

In diagram No. 47 let A be the observer, O the Sun, and H the Sensible Horizon. If you take the Altitude of the Lower Limb of the Sun you will get the angle DAH, and as you require to know the Altitude of the Sun's centre, it is evident that you must *add* the angle subtended from the Earth by the Semi-Diameter of the Sun, namely the angle OAD.

The diagram also shows that if you observe the Sun's Upper Limb you get the angle EAH, from which you must *subtract* the angle subtended from the Earth by the Semi-Diameter of the Sun, namely the angle EAO.

This correction gives the Altitude of the Sun's centre



THIS PAGE IS LOCKED TO FREE MEMBERS

Purchase full membership to immediately unlock this page

SAVE \$3,999,994

Did you know we sell
paperback books too?

To buy our entire catalog
in paperback would cost
over \$4,000,000

Access it all now for
\$8.99/month

*Fair usage policy applies

Continue

This correction, which is always to be *deducted*, gives us the real Altitude of the Sun's centre above the Sensible Horizon.

But as we require the Altitude of the Sun's centre above the Rational Horizon, a further correction, due to the Earth's Semi-Diameter, is necessary. This is called *Parallax*.

FIG. 49

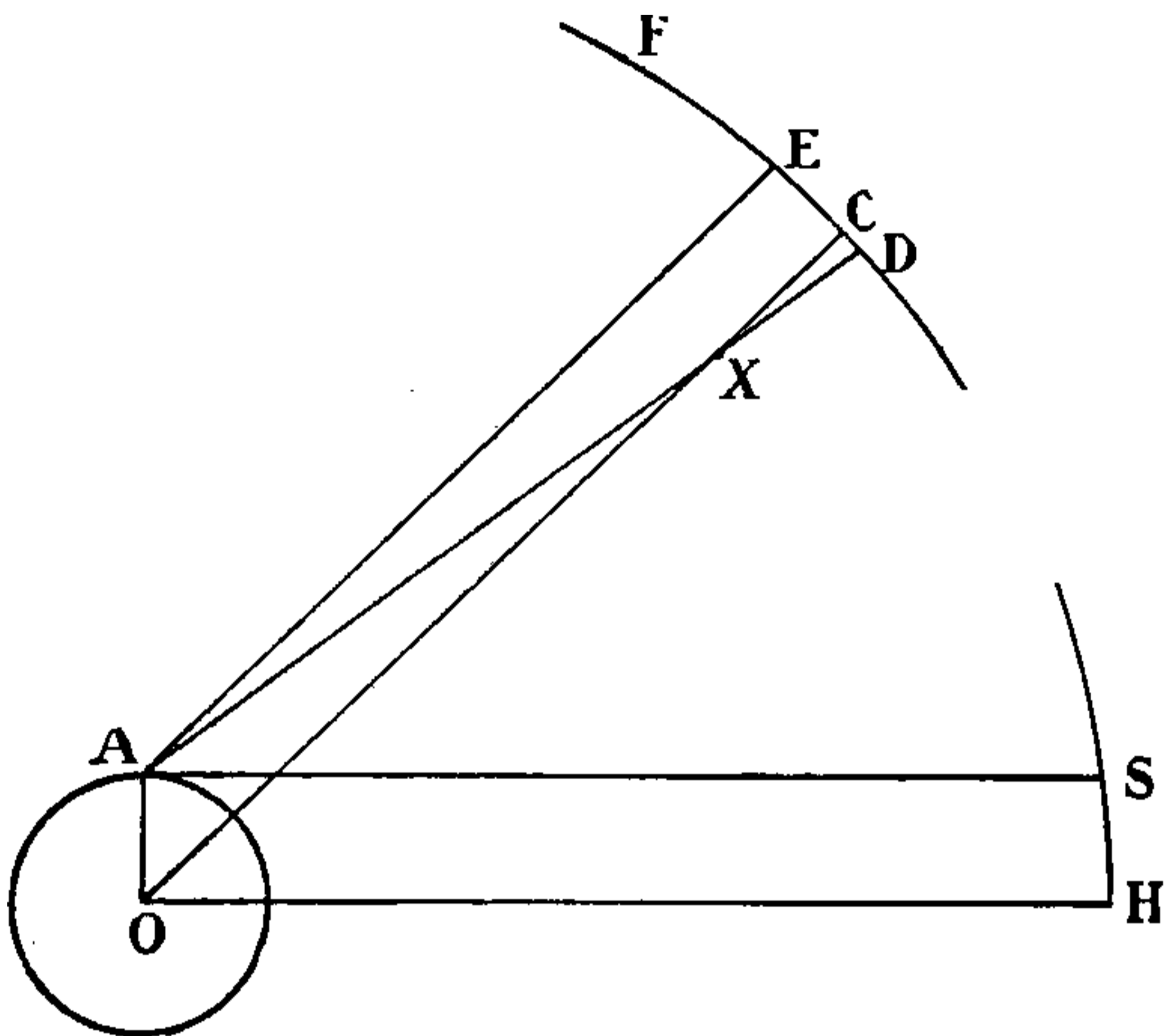

Let FH be a portion of the celestial concave; O the centre of the Earth; A an observer on its surface; X the position of a Heavenly Body; H a point on the Rational Horizon; S a point on the Sensible Horizon. Draw AE parallel to OC , and as AS and OH are parallel the angles EAS and COH are equal. The angle EAS equals the sum of the angles EAX and XAS ; the angle EAX equals the angle $A XO$ because the lines AE and OX are parallel to one another. XOH is the True Altitude of X . But in consequence of the height of the observer above the centre of the Earth O , the Altitude of X appears to be XAS . Now the True Altitude XOH is the sum of the two angles XAS and EAX .

EAX equals AXO , which is the Parallax (the angle at a Heavenly Body subtended by the radius of the Earth between the observer and the centre of the Earth) and XAS is the Apparent Altitude, therefore Parallax added to Apparent Altitude gives the True Altitude.

This correction is always *additive*, and having been made, we at last have the *True* Altitude, that is to say, the Altitude of the centre of the Sun above the Rational Horizon. So far so good. The only other datum required is the Declination of the Sun.

The Declination will be found for the day required at Apparent Noon at Greenwich in page I. of each month in the Nautical Almanac, and alongside is the variation in one hour. As the Sun is moving North or South all the time, and its Declination is therefore constantly changing, and as Declination is given in the Almanac for Greenwich *Noon*, it is necessary to find out what time it is at Greenwich when it is Noon at Ship, so as to be able to correct the Declination for the interval of time that has elapsed since Noon at Greenwich. All you have to do is to find your Longitude by Dead Reckoning, and turn it into time. As a circle contains 360 degrees of arc, or 24 hours of time, one hour is equal to 15 degrees, and in order to turn arc into time it must be divided by 15. The best way of doing so is to divide the arc by 5 and then the quotient by 3; but the whole thing is calculated for you in Tables, and the simplest plan of all is to look out your Longitude in Arc in Table A, and take out the equivalent in Time.

Having obtained your Longitude in Time, if you are West of Greenwich, it will be that much past Noon at Greenwich when it is Noon with you. To find the correction for Declination due to this interval of time, the

variation in one hour must be multiplied by the interval. It is not necessary to be accurate in this operation. It is quite sufficient to multiply the minutes and nearest decimal of a minute of variation by the nearest decimal of an hour, or by the hour or hours and nearest decimal of an hour of your Longitude in Time. This correction is to be added to or taken from the Declination, as the case requires. If it is past Noon at Greenwich at the time it was Noon at Ship, and if the Declination is increasing, the correction must of course be added, but if the Declination is decreasing, it must be subtracted.

But suppose you are in East Longitude—East of Greenwich. It will not yet be Noon at Greenwich when it is Noon at Ship, and your Longitude in Time East will be the interval *before* Greenwich Noon. In this case you can proceed in two ways. Either you can take your Longitude in Time from 24 hours and treat the balance as an interval *past* Noon, of the *preceding* day; or you can correct the Declination for the interval of time *before* Noon at Greenwich on *the* day. The first process is unnecessarily laborious, and you should accustom yourself to the second method; all you must remember is, that in such a case, if the Declination is *increasing*, the correction is to be *deducted* from the Declination as given for Noon at Greenwich, and if the Declination is *decreasing* the correction is to be *added*.

Having now obtained the two data necessary to work the problem, namely, the True Altitude of the Sun, and its Declination at the time the sight was taken, namely, when the Sun was on your Meridian—Apparent Noon at Ship—we will proceed to find the Latitude.



THIS PAGE IS LOCKED TO FREE MEMBERS

Purchase full membership to immediately unlock this page

DELVE INTO FANTASY, MAGIC, MYTHOLOGY & FOLKLORE

Forgotten Books'
Full Membership gives
access to 797,885 ancient
and modern, fiction and
non-fiction books.

Continue

*Fair usage policy applies

Index Error, can be taken out in one fell swoop from Table IX., which saves some trouble, but this will not do for the Board of Trade Examination.

It is well to mention that some difficulty may be experienced in correcting Declination at the time when it changes its name at the Equinoxes.

We all know that, in the Northern Hemisphere, the Sun moves North, or, to be accurate, its apparent motion is North from the shortest to the longest day, and it moves South from the longest to the shortest day. It changes its Declination from North to South of the Equator at the Autumnal Equinox, and from South to North at the Spring Equinox. About the Equinoxes it may well happen that the Sun crosses the line from North to South Declination or from South to North Declination during the interval between Noon at Ship and Noon at Greenwich. For instance, suppose you observe the Meridian Altitude of the Sun on March 20th, 1898, in Longitude $90^{\circ} 0' 0''$ West. Longitude in Time is 6 hours, variation in one hour is $59.3''$, which multiplied by 6 equals $5' 56''$.

$$\begin{array}{r}
 59.3 \\
 6 \\
 \hline
 60 \) \ 355.8 \ (\ 5' \ 56'' \\
 \underline{300} \\
 55.8
 \end{array}$$

Declination at Greenwich Noon is $0^{\circ} 1' 57''$ South. As the Sun has gone North $5' 56''$ in the 6 hours, and was only $0^{\circ} 1' 57''$ South at Greenwich Noon, it is evident that it must have crossed the Equator. The Declination at Noon, $0^{\circ} 1' 57''$ South, must be deducted from the distance the Sun has moved to the Northward to ascertain the Declination at the time the sight was taken. Therefore $5' 56'' - 1' 57'' =$ Declination $3' 59''$ North.

Here are some examples of Latitude by Meridian Altitude of the Sun :

Examples

1. On January 6th, 1898, in Longitude 135° W, the Observed Altitude of the Sun's Lower Limb was 71° 27' 20'', bearing South, Index Error + 1' 20'', Height of Eye 18 feet. Required the Latitude.

<i>Long. in Time</i>	<i>Declination</i>
Long. 135° W = 9 ^h W (Table A)	Dec. at App. Noon Greenwich, Jan. 6th
<i>To correct Dec.</i>	(p. I., Naut. Almanac) (decreasing) } 22° 27' 46'' S
Var. in 1 ^h = 18.4''	Correction - 2 46
Long. in Time × 9	Dec. at App. Noon at Ship 22 25 0 S
$\begin{array}{r} 60 \overline{) 165.6} \quad (2' 46'' \\ \underline{120} \\ 45 \end{array}$	

Obs. Mer. Alt. ☉	71° 27' 20'	S	
I. E.	+ 1' 20''		
	71° 28' 40''		
Dip 18 feet . . .	4' 9''	Table V.	
	71° 24' 31''		
☉ Semi-Diameter	16' 17''	p. II. Naut. Almanac.	
	71° 40' 48''		
Apparent Altitude	71° 40' 48''		
Refraction . . .	18''	Table IV.	
	71° 40' 30''		
Parallax	3''	Table VI.	
	71° 40' 33''		
True Altitude	71° 40' 33''	S	
	90° 00' 00''		
Zenith Distance	18° 19' 27''	N	
Declination . . .	22° 25' 0''	S	
	4° 5' 33''	S	
Latitude			

Note.—If you use Inman's Tables no Parallax must be applied, because Table 16 gives you Refraction diminished by the Sun's Parallax.

2. On March 20th, 1898, in Longitude 157° 20' W, the Observed Meridian Altitude of the Sun's Lower Limb was

$30^{\circ} 20' 10''$, bearing South, Index Error $-0' 50''$, Height of Eye 35 feet. Required the Latitude.

Long. $157^{\circ} 20' = 10^{\text{h}} 29^{\text{m}} 20^{\text{s}}$ (Table A)

<p><i>Correction for Dec.</i> Var. in $1^{\text{h}} = 59.3$ Long. in T. = 10.5</p> <hr style="width: 20%; margin: 0 auto;"/> <p style="text-align: center;">2965 5930</p> <hr style="width: 20%; margin: 0 auto;"/> <p>60)622.65 ($10' 23''$ 600 <hr style="width: 20%; margin: 0 auto;"/> 22.65</p>	<table style="width: 100%; border-collapse: collapse;"> <tr> <td style="width: 60%;">\odot Dec. at Greenwich Noon</td> <td style="width: 5%;"></td> <td style="width: 35%; text-align: right;">$0^{\circ} 2' 5''$ S</td> </tr> <tr> <td>on March 20th (decreasing)</td> <td></td> <td></td> </tr> <tr> <td>Corr.</td> <td></td> <td style="text-align: right;">$10' 23''$</td> </tr> <tr> <td>\odot Dec. at time of obs.</td> <td></td> <td style="text-align: right;">$0^{\circ} 8' 18''$ N</td> </tr> </table> <table style="width: 100%; border-collapse: collapse;"> <tr> <td style="width: 60%;">Obs. Mer. Alt. \odot</td> <td style="width: 5%;"></td> <td style="width: 35%; text-align: right;">$30^{\circ} 20' 10''$ S</td> </tr> <tr> <td>I. E.</td> <td></td> <td style="text-align: right;">$- 0' 50''$</td> </tr> <tr> <td></td> <td></td> <td style="text-align: right;"><hr style="width: 20%; margin: 0 auto;"/></td> </tr> <tr> <td></td> <td></td> <td style="text-align: right;">$30^{\circ} 19' 20''$</td> </tr> <tr> <td>Dip 35 ft.</td> <td></td> <td style="text-align: right;">$5' 48''$ Table V.</td> </tr> <tr> <td></td> <td></td> <td style="text-align: right;"><hr style="width: 20%; margin: 0 auto;"/></td> </tr> <tr> <td></td> <td></td> <td style="text-align: right;">$30^{\circ} 13' 32''$</td> </tr> <tr> <td>Semi-Diameter</td> <td></td> <td style="text-align: right;">$16' 5''$ p. II. Naut. Almanac</td> </tr> <tr> <td></td> <td></td> <td style="text-align: right;"><hr style="width: 20%; margin: 0 auto;"/></td> </tr> <tr> <td>Apparent Altitude</td> <td></td> <td style="text-align: right;">$30^{\circ} 29' 37''$</td> </tr> <tr> <td>Refraction</td> <td></td> <td style="text-align: right;">$1' 37''$ Table IV.</td> </tr> <tr> <td></td> <td></td> <td style="text-align: right;"><hr style="width: 20%; margin: 0 auto;"/></td> </tr> <tr> <td></td> <td></td> <td style="text-align: right;">$30^{\circ} 28' 0''$</td> </tr> <tr> <td>Parallax</td> <td></td> <td style="text-align: right;">$8''$ Table VI.</td> </tr> <tr> <td></td> <td></td> <td style="text-align: right;"><hr style="width: 20%; margin: 0 auto;"/></td> </tr> <tr> <td>True Altitude</td> <td></td> <td style="text-align: right;">$30^{\circ} 28' 8''$ S</td> </tr> <tr> <td></td> <td></td> <td style="text-align: right;">$90^{\circ} 0' 0''$</td> </tr> <tr> <td></td> <td></td> <td style="text-align: right;"><hr style="width: 20%; margin: 0 auto;"/></td> </tr> <tr> <td>Zenith Distance</td> <td></td> <td style="text-align: right;">$59^{\circ} 31' 52''$ N</td> </tr> <tr> <td>Declination</td> <td></td> <td style="text-align: right;">$0^{\circ} 8' 18''$ N</td> </tr> <tr> <td></td> <td></td> <td style="text-align: right;"><hr style="width: 20%; margin: 0 auto;"/></td> </tr> <tr> <td>Latitude</td> <td></td> <td style="text-align: right;">$59^{\circ} 40' 10''$ N</td> </tr> </table>	\odot Dec. at Greenwich Noon		$0^{\circ} 2' 5''$ S	on March 20th (decreasing)			Corr.		$10' 23''$	\odot Dec. at time of obs.		$0^{\circ} 8' 18''$ N	Obs. Mer. Alt. \odot		$30^{\circ} 20' 10''$ S	I. E.		$- 0' 50''$			<hr style="width: 20%; margin: 0 auto;"/>			$30^{\circ} 19' 20''$	Dip 35 ft.		$5' 48''$ Table V.			<hr style="width: 20%; margin: 0 auto;"/>			$30^{\circ} 13' 32''$	Semi-Diameter		$16' 5''$ p. II. Naut. Almanac			<hr style="width: 20%; margin: 0 auto;"/>	Apparent Altitude		$30^{\circ} 29' 37''$	Refraction		$1' 37''$ Table IV.			<hr style="width: 20%; margin: 0 auto;"/>			$30^{\circ} 28' 0''$	Parallax		$8''$ Table VI.			<hr style="width: 20%; margin: 0 auto;"/>	True Altitude		$30^{\circ} 28' 8''$ S			$90^{\circ} 0' 0''$			<hr style="width: 20%; margin: 0 auto;"/>	Zenith Distance		$59^{\circ} 31' 52''$ N	Declination		$0^{\circ} 8' 18''$ N			<hr style="width: 20%; margin: 0 auto;"/>	Latitude		$59^{\circ} 40' 10''$ N
\odot Dec. at Greenwich Noon		$0^{\circ} 2' 5''$ S																																																																													
on March 20th (decreasing)																																																																															
Corr.		$10' 23''$																																																																													
\odot Dec. at time of obs.		$0^{\circ} 8' 18''$ N																																																																													
Obs. Mer. Alt. \odot		$30^{\circ} 20' 10''$ S																																																																													
I. E.		$- 0' 50''$																																																																													
		<hr style="width: 20%; margin: 0 auto;"/>																																																																													
		$30^{\circ} 19' 20''$																																																																													
Dip 35 ft.		$5' 48''$ Table V.																																																																													
		<hr style="width: 20%; margin: 0 auto;"/>																																																																													
		$30^{\circ} 13' 32''$																																																																													
Semi-Diameter		$16' 5''$ p. II. Naut. Almanac																																																																													
		<hr style="width: 20%; margin: 0 auto;"/>																																																																													
Apparent Altitude		$30^{\circ} 29' 37''$																																																																													
Refraction		$1' 37''$ Table IV.																																																																													
		<hr style="width: 20%; margin: 0 auto;"/>																																																																													
		$30^{\circ} 28' 0''$																																																																													
Parallax		$8''$ Table VI.																																																																													
		<hr style="width: 20%; margin: 0 auto;"/>																																																																													
True Altitude		$30^{\circ} 28' 8''$ S																																																																													
		$90^{\circ} 0' 0''$																																																																													
		<hr style="width: 20%; margin: 0 auto;"/>																																																																													
Zenith Distance		$59^{\circ} 31' 52''$ N																																																																													
Declination		$0^{\circ} 8' 18''$ N																																																																													
		<hr style="width: 20%; margin: 0 auto;"/>																																																																													
Latitude		$59^{\circ} 40' 10''$ N																																																																													

Note.—In this case the Sun moved $10' 23''$ North during the interval between Greenwich Noon and Noon at Ship, and, as the Sun was only $2' 5''$ South of the Equator at Greenwich Noon, it is obvious that it crossed the line into North Declination during the interval. $2' 5''$ must therefore be deducted from the correction $10' 23''$ to give you the Sun's Declination when on your Meridian.

It may happen on or very close to the Equator, that applying the corrections to your Observed Altitude will bring the Sun across the Zenith and will give you an Altitude of more than 90° , which is of course impossible and absurd. Such a problem is just the kind of tricky thing that you might find on an examination paper. Don't be puzzled. All you have to do is to take the Altitude,



THIS PAGE IS LOCKED TO FREE MEMBERS

Purchase full membership to immediately unlock this page

SAVE \$3,999,994

Did you know we sell
paperback books too?

To buy our entire catalog
in paperback would cost
over \$4,000,000

Access it all now for
\$8.99/month

*Fair usage policy applies

Continue

involved in the problem ; but don't bother about it unless you feel so inclined.

Diagrams No. 50, 51, 52 are on the plane of the Celestial Meridian $H_1 B Z D C$. Let Z be the Zenith of an observer on the Earth at A , and $H H_1$ his Rational Horizon. Let $P Q P_1 Q_1$ represent the Earth, $P P_1$ being the Poles

FIG. 50

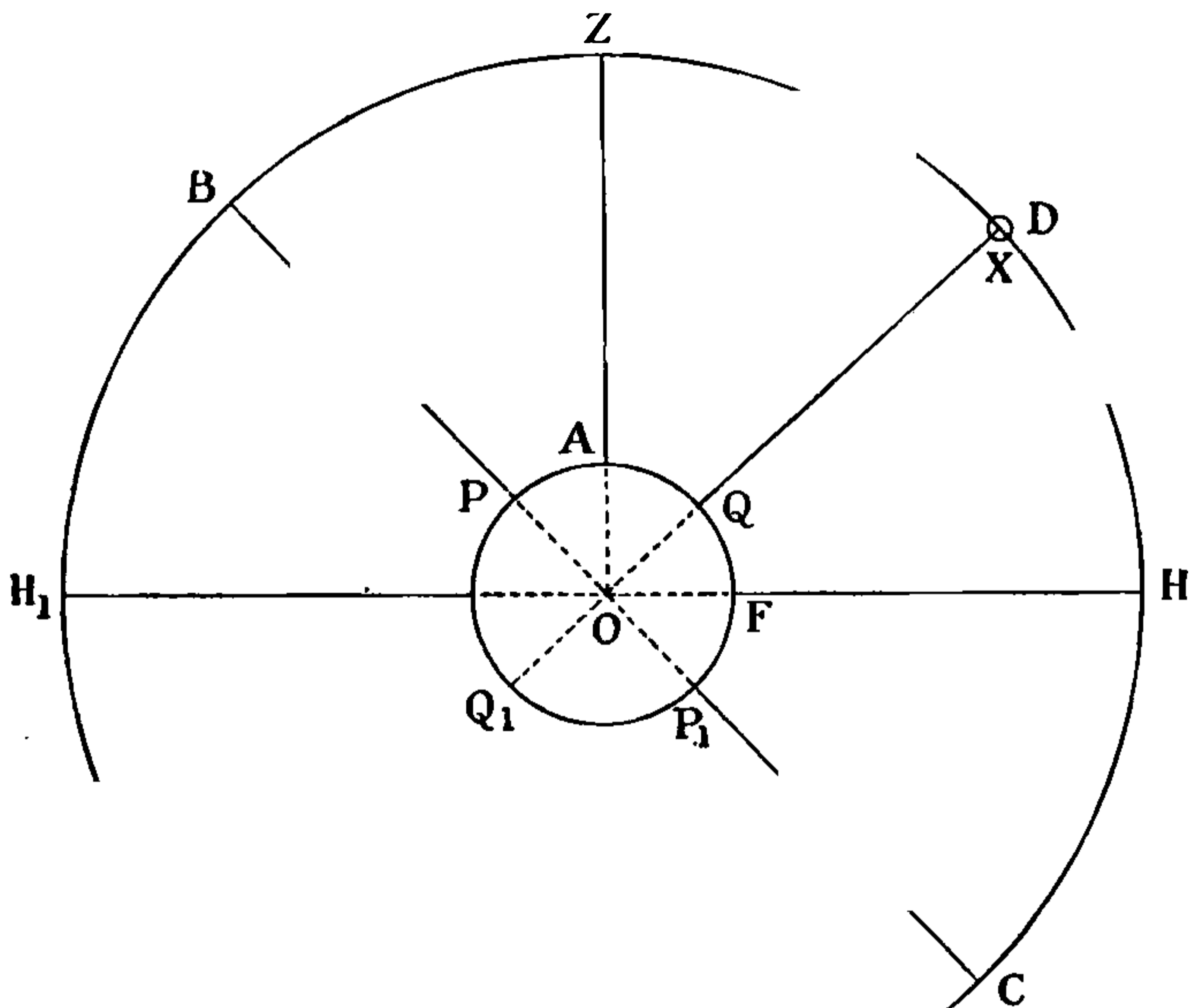

and $Q Q_1$ the Equator ; D is therefore the spot where the Equinoctial cuts the Celestial Meridian, and B and C are the Celestial Poles. Let x be the Sun on the Meridian of the observer at A .

The arc x to H , or what is the same thing, the angle $x O H$ is the True Altitude of the Sun at Noon, that is when on the Meridian of the observer. The Zenith being perpendicular to the Horizon, the arc $Z H$, or angle $Z O H = 90^\circ$. The Zenith Distance, that is to say the arc $Z x$, which is the distance of the Sun from the Zenith, is 90° less the True Altitude, that is $90^\circ - x H$.

We have now got the position of the Sun in reference to a fixed point, the Zenith of the observer. The Declination of the Sun, *i.e.* its angular distance North or South of the Equator, must be considered.

The Latitude of the observer is QA , that is his distance

FIG. 51

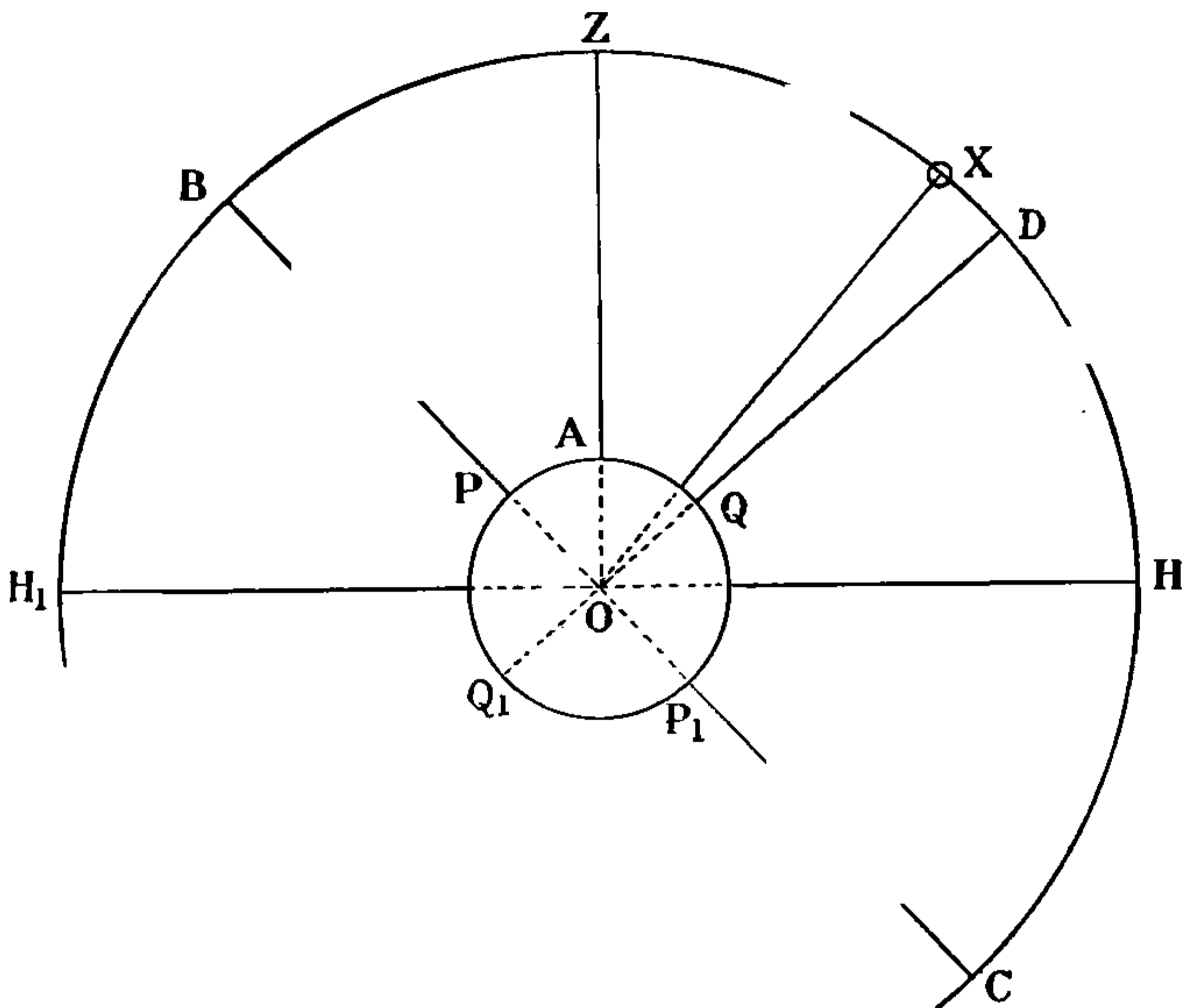

from the Equator, measured by the angle $Q O A$. This angle obviously also measures the distance $D Z$, which is therefore equal to the Latitude of the observer. If the Sun has no Declination, that is to say if he is at x as in fig. 50, the Latitude will be equal to the Zenith Distance, as obviously the angles $Z O X$ and $Q O A$ are the same.

But if the Sun has Declination North, as in fig. 51, it must be taken into consideration. If the observer and the Sun are both on the same side, either both North or both South of the Equator, the sum of the Zenith Distance and Declination is the Latitude. Thus, in fig. 51 $Z X$ (the Zenith Distance) + $X D$ (the Declination) = $Z D$, which

has already been shown to be equal to the Latitude AQ . But suppose the Sun and the observer to be on opposite sides of the Equator, as in fig. 52.

DX is the Declination South of the Equator, A is the position of the observer North of the Equator. zX (the Zenith Distance) $- DX$ (the Declination), gives DZ , which equals the Latitude AQ , because the angular distances zD and QA are the same, as they are both measured by the same angle at O .

FIG. 52

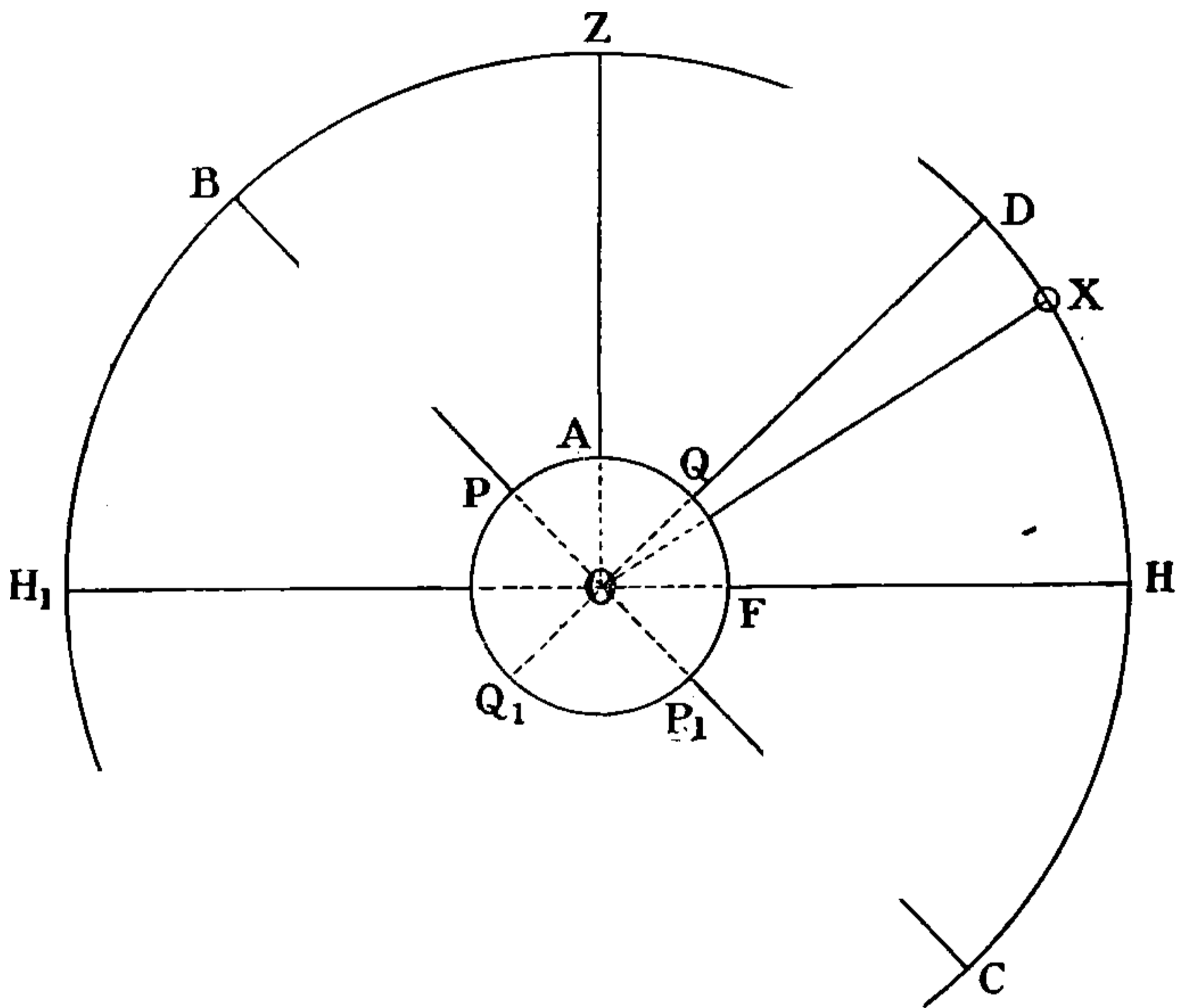

The gist of the whole matter is this. Your observation gives you the angle between the Sun and the Zenith: the Nautical Almanac gives the angle from the Sun to the Equator, and by these two facts by addition or subtraction you deduce the angle from the Equator to the Zenith, which is your Latitude.

This may be seen perhaps more clearly in a figure constructed on the plane of the Horizon, as in fig. 53.



THIS PAGE IS LOCKED TO FREE MEMBERS

Purchase full membership to immediately unlock this page

DELVE INTO FANTASY, MAGIC, MYTHOLOGY & FOLKLORE

Forgotten Books'
Full Membership gives
access to 797,885 ancient
and modern, fiction and
non-fiction books.

Continue

*Fair usage policy applies

owing to the slow movement of the Body in Altitude when near the Meridian, very accurate contact can be obtained, and because the problem is so simple.

So much for Latitude by a Meridian Altitude of the Sun.

Latitude can be found by a Meridian Altitude of a fixed star, a planet, or of the Moon ; also by Altitudes of circumpolar stars above and below the Pole and by Double Altitudes. All these problems will be dealt with later on. Having learned how to find the Latitude by the ordinary method of a Meridian Altitude of the Sun, let us proceed to find our Longitude with the help of the same luminary.

CHAPTER XIII

LONGITUDE

Longitude by Sun and Chronometer.—This problem consists in comparing the Time at Ship as found from observation with Greenwich Time as found by referring to your Chronometer.

Longitude is measured along the Equator, and is counted East and West from the Meridian of Greenwich. The Meridian of Greenwich is $0^{\circ} 0' 0''$, and Longitude is counted so many degrees, minutes, and seconds of Arc East up to 180° , and West up to 180° , thus completing a circle; a circle always contains 360 degrees.

Longitude must be first expressed in terms of Time—so many hours, minutes, and seconds of Time East or West—and is then converted into Arc—or so many degrees, minutes, and seconds of Arc East or West.

It may not be amiss to recur a little to the important subject of Time.

Three sorts of Time are in ordinary use: Sidereal Time, which we need not discuss now; Solar Apparent Time; and Solar Mean Time. Apparent Time is derived from the Apparent Sun, that is the real actual Sun;

Mean Time is derived from the Mean or imaginary Sun.

Apparent Time is an expression which may possibly be misleading; it is in fact *real* Time—the Time by the Sun, and the Sun lies at the foundation of our conception of Time. The apparent motion of the Sun from East to West round the Globe in 24 hours, due to the real rotation of the Earth from West to East in 24 hours, gives us day and night, and, so to speak, manufactures Time. The term '*Apparent*' is correct and quite satisfactory provided it is understood that it is the *real* time derived directly from observations of the *real* Sun.

But the Sun is in one sense a bad timekeeper, for the length of the Solar Day—that is the interval of time between the instants when the Centre of the Sun is on the Meridian on two successive days—is not uniform. There are two reasons for this. 1st, owing to the inclination of the Earth's orbit round the Sun, part of the Sun's apparent Motion is North and South, and it is only the East and West part of its Motion which gives us the measure of the Solar Day. 2nd, the shape of the Earth's orbit round the Sun being elliptic, and the speed of the Earth varying according to its proximity to the Sun, the Sun appears to move faster at some times than others. To get over the difficulty thus arising a Mean Sun keeping Mean Time, and giving us a Mean Day calculated on the average length of the Solar Days in the Year, has been invented.

This artificial measure of Time is called '*Mean*' Time. The difference between Mean Time and Apparent Time is called the '*Equation of Time*.' The Equation of Time is given with directions as to how it is to be



THIS PAGE IS LOCKED TO FREE MEMBERS

Purchase full membership to immediately unlock this page

SAVE \$3,999,994

Did you know we sell
paperback books too?

To buy our entire catalog
in paperback would cost
over \$4,000,000

Access it all now for
\$8.99/month

*Fair usage policy applies

Continue

In diagram No. 54, let $PQ P_1 Q_1$ be the Earth, P being the North Pole, P_1 the South Pole, $QL Q_1$ the Equator. Let G be the position of Greenwich and $PGL P_1$ the Meridian of Greenwich, let ABC and D be places on the surface of the Earth situated on the Meridians $PM P_1$, $PN P_1$, $PO P_1$ and $PR P_1$ respectively. Then the arc LM is the Longitude of A , East of Greenwich; the arc LN is the Longitude of B , East of Greenwich; the arc LO is the

FIG. 54

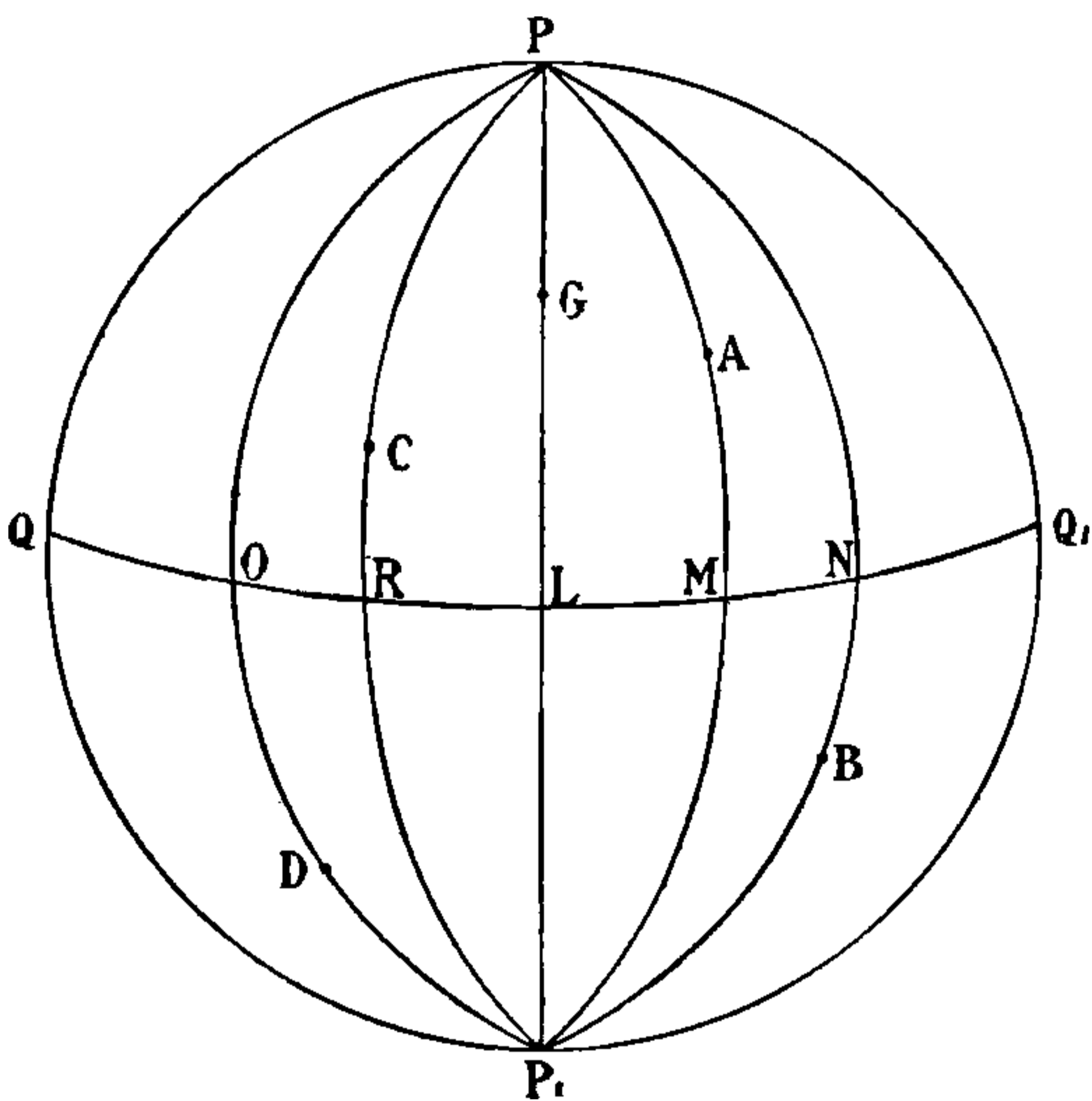

Longitude of D , West of Greenwich; and the arc LR is the Longitude of C , West of Greenwich.

In diagram No. 55, let $TQ_1 L Q$ be the Earth and P the North Pole, PM and PR the Meridian of A and C , and PN and PO the Meridians of B and D in the diagram No. 54, which, as they are South of the Equator, you cannot see in this diagram. The Longitudes of all these places are represented in both diagrams by the same arcs, and all the places are in less than 90° of Longitude. Now let K , S , and F be three other places in the Northern

Hemisphere. F is in Longitude 180° E or 180° W, whichever you please; K is in Longitude LX East; and S is in Longitude LY West.

You will notice that all these positions are measured by the angles at the Pole. Longitudes are determined in the problem you are about to consider by finding the polar angles in certain triangles. The Polar Angle of the Sun is called the Horary Angle or Hour Angle; the latter

FIG. 55

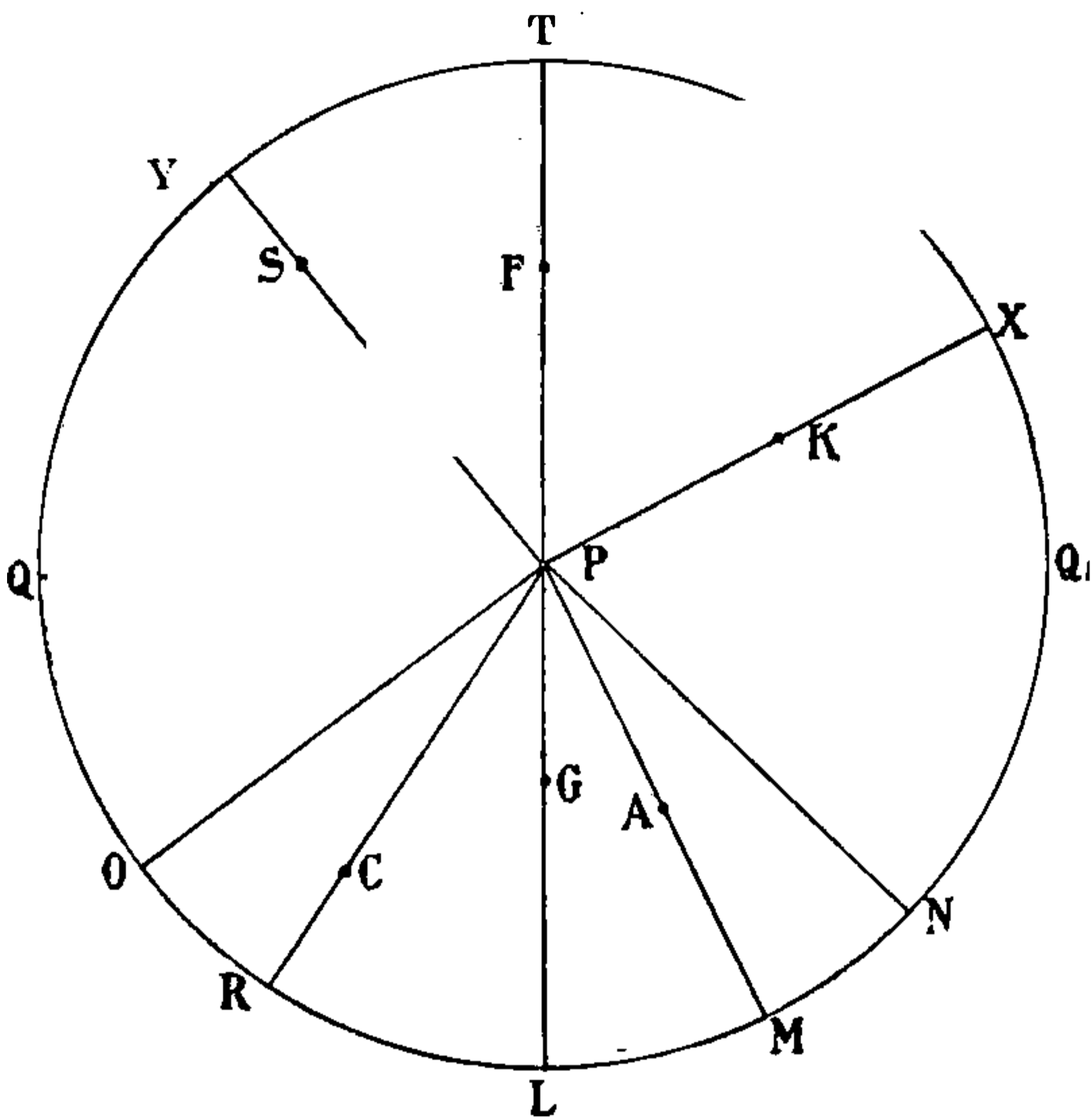

expression being the better English of the two, I shall use it, and, for the future, when referring to the Sun's Polar Angle I shall call it the 'Hour Angle.'

It is 360° right round the Equator, as it is round any and every circle; and, as the Sun moves round the Earth in 24 hours, it is also 24 hours round the Equator. Longitude may therefore be computed in Time just as well as in Arc, up to 12 hours East and 12 hours West of Greenwich.

Apparent Time at Ship is the Westerly Hour Angle of the Apparent, that is the real, Sun ; or it is the arc of the Equinoctial intercepted between the Meridian of the observer and the Meridian passing through the centre of the Sun ; and it is measured to the Westward from the Meridian of the observer right round the Equinoctial.

Longitude is found by the aid of the Sun and a Chronometer : 1st, by ascertaining by observation and calculation the Sun's Hour Angle, which is Apparent Time at Ship at the moment the sight is taken ; 2nd, by turning Apparent Time into Mean Time by applying the Equation of Time, and 3rd, by comparing Mean Time at Ship thus found with Mean Time at Greenwich, as ascertained from your Chronometer. The difference between the two is the Longitude in Time.

As the Sun moves from East to West it is obvious that Greenwich Time will be greater than Ship Time if the Ship is in West Longitude, and *vice versa*. When the Sun is rising at Greenwich, it will be still below the Horizon West of Greenwich, and will be above the Horizon East of Greenwich. As an instance : Bombay is in Longitude $72^{\circ} 49' 40''$ East, and New York is in Longitude $74^{\circ} 0' 0''$ West ; or, converted into Time, Bombay is 4 h. 51 m. 19 s. East of Greenwich, and New York is 4 h. 56 m. 0 s. West of Greenwich. When it is Noon at Greenwich say on Tuesday, it is 4 h. 51 m. 19 s. P.M. at Bombay, or expressed nautically it is Tuesday 4h. 51 m. 19 s. ; and at the same instant of Noon at Greenwich it is 7 h. 4 m. A.M. on Tuesday at New York by Civil Time or expressed nautically it is Monday 19 h. 4 m.

Therefore if Greenwich Time is greater than Ship Time name your Longitude West ; if Greenwich Time is



THIS PAGE IS LOCKED TO FREE MEMBERS

Purchase full membership to immediately unlock this page

DELVE INTO FANTASY, MAGIC, MYTHOLOGY & FOLKLORE

Forgotten Books'
Full Membership gives
access to 797,885 ancient
and modern, fiction and
non-fiction books.

Continue

*Fair usage policy applies

First formula :

Altitude + Latitude + Polar Distance = the sum.

Sum $\div 2$ = the $\frac{1}{2}$ sum.

$\frac{1}{2}$ sum - Altitude = Remainder.

Log. Secant of the Latitude + Log. Cosecant of the Polar Distance + Log. Cosine of the $\frac{1}{2}$ sum + Log. Sine of the remainder = Log. of the Hour Angle.

The word 'Alp,' composed of three initial letters, may serve to remind you of Altitude, Latitude, Polar Distance; and Secant, Cosecant, Cosine, Sine is not very difficult to remember.

The problem presents the following appearance :

Alt.	— — —		
Lat.	— — —	Log. Sec .	— — —
P. D.	— — —	Log. Cosec	— — —
	—————		
Sum 2)	— — —		
	—————		
$\frac{1}{2}$ sum	— — —	Log. Cos .	— — —
	—————		
Remainder	— — —	Log. Sin .	— — —
			—————
		Log. H. A.	— — —

The sum of the four Logs. is (rejecting tens in the Index) the Log. of the Hour Angle. It is an angle East if the Sun is East of the Meridian, as in the case of a forenoon sight; it is an angle West if the Sun is West of the Meridian, as in the case of an afternoon sight.

Second formula :

Find the sum of Latitude and Declination if they are of different names, or their difference if they are of the same name. To the result so obtained apply the Zenith Distance, finding both the sum and the difference. Add together the Log. Secant of the Latitude, the Log Secant of the Declination, the $\frac{1}{2}$ Log. Haversine of the sum, and the $\frac{1}{2}$ Log Haversine of the difference: the result is the Log. Haversine of the Hour Angle.

The problem presents the following appearance :

Lat.	.	.	.	Log. Sec	—	—	—
Dec.	.	.	.	Log. Sec	—	—	—
<hr style="width: 20%; margin-left: 0;"/>							
Sum or Diff.	.	.	.				
Z. D.	.	.	.				
<hr style="width: 20%; margin-left: 0;"/>							
Sum	.	.	.	$\frac{1}{2}$ Log. Hav	—	—	—
Diff.	.	.	.	$\frac{1}{2}$ Log. Hav	—	—	—
<hr style="width: 20%; margin-left: 0;"/>							
Log. Hav of Hour Angle =					—	—	—

If you adopt this formula use Inman's Tables, in which Log. Haversines and $\frac{1}{2}$ Log. Haversines are given in Tables 34, 33. Take your choice of these two formulas—I personally prefer the former, probably because I learned it first—and having made your choice commit it to memory and stick to it.

In order to work a Longitude by Chronometer problem you must understand how to use Tables XXXI.¹ and XXXII. Table XXXI. gives the Logs. for finding Hour Angles or Apparent Time. The hours are at the top and bottom of the page, the minutes are on the left and right in columns headed M. The seconds are given for every five seconds at the top and bottom in columns headed 0^s, 5^s, 10^s &c., &c., and the 'proportional parts' every intermediate second are on the right in a column headed 'Pro. Pts.' You need never take anything out from the bottom of the page, the Hour Angles from the bottom being merely what the Hour Angles at the top want of 24 hours.

To find an Hour Angle from a Log.—Look for the Log. and take out the hour at the top, the minute on the left and the second on the top appropriate to it. If you cannot find your Log. exactly, look at the Log. nearest to it, greater or less, and take out the hour, minute and second appertaining to it. Find the difference between

¹ In the 1900 edition of Norie a complete table of Log. Haversines is given from 0^h to 12^h.

the Log. taken out and your Log.; from the Pro. Pts. Column on the right take out the seconds belonging to the difference, and add these seconds to the Hour Angle if the Log. taken out is smaller than your Log., or deduct them from the Hour Angle if the Log. taken out is greater than your Log.

To find the Log. corresponding to an Hour Angle.— Look for the hour at the top, the minute on the left, and the second—or nearest second—on the top, and take out the corresponding Log. If you have an odd number of seconds in your Hour Angle find the proportional parts belonging to them, and add them to or take them from the Log., according as the case requires.

To return to our problem. If the sight be taken before Noon you get, of course, an Hour Angle East. Twenty-four hours being the time taken by the Sun in travelling from any Meridian right round to the same Meridian, it follows that an Hour Angle East can be converted into an Hour Angle West by taking it from 24 hours and setting the date back one day. For instance the Sun having an Hour Angle East of four hours on Monday has an Hour Angle West of 20 hours on Sunday. Therefore in the case of a forenoon sight take the Easterly Hour Angle from 24 hours, and the result is the Hour Angle West, that is to say Apparent Time at Ship on the day before. If the sight be taken in the afternoon the Hour Angle is West, that is, it is Apparent Time at Ship on the day the sight is taken. In both cases apply the Equation of Time to the Westerly Hour Angle, and you have Mean Time at Ship. Find the difference between the Mean Time at Ship and Mean Time at Greenwich, and you have your Longitude in Time. But remember this in applying your Ship Mean Time to Greenwich Mean Time: if you have taken a forenoon sight you have obtained an Easterly Hour Angle which you have turned



THIS PAGE IS LOCKED TO FREE MEMBERS

Purchase full membership to immediately unlock this page

SAVE \$3,999,994

Did you know we sell
paperback books too?

To buy our entire catalog
in paperback would cost
over \$4,000,000

Access it all now for
\$8.99/month

*Fair usage policy applies

Continue

order to find out whether the Chronometer is showing Greenwich Time A.M. or P.M.

For example, suppose that in Longitude 165° W, you take a sight at about 8 A.M. on January 18th, and that your Chronometer corrected for error on M.T.G. shows 7 h. 0 m. 26 s., what does it mean? Proceed to find out in this way :

Approximate Ship Time on the 17th	20 ^b 0 ^m 0 ^s
Long. in Time W	11 0 0
Approximate Greenwich Time 17th .	31 0 0
	24 0 0
" " " 18th .	7 0 0

and it is clear that your Chronometer indicated M.T.G. on the 18th 7 h. 0 m. 26 s.

Take another case.

Suppose that in Longitude 145° E you took a sight at about 4 P.M. on June 1st, when the Chronometer corrected for error on M. T. G. showed 6 h. 19 m. 42 s., what does it mean ?

Approximate Ship Time on June 1st .	4 ^b 0 ^m 0 ^s
Long. in Time E	9 40 0
Approximate Greenwich Time May 31st.	18 20 0

In this case Longitude being East you have to deduct the Longitude in Time from Ship Time in order to get the Greenwich date, and to do so you must mentally borrow 24 hours and add it to the Ship Time. Ship Time is 4 hours after Noon on June 1st, which, with 24 hours added, is 28 hours after Noon on May 31st; deducting 9 h. 40 m. from 28 h. you have a Greenwich Date of 18 h. 26 m. on May 31st, or, approximately, what was shown on the Chronometer, namely, 6 h. 19 m. 42 s. A.M. on June 1st.

To get an accurate Longitude it is of course absolutely necessary to be able to ascertain the exact Time at Greenwich by inspection of your Chronometer. You must know how much your Chronometer is fast or slow of

Greenwich Time; and months, or anyhow weeks, may have elapsed since an opportunity occurred of comparing your Chronometer with Greenwich Time. But you will know your Chronometer's rate—how much it is gaining or losing every day—and by that means you can ascertain the difference between your Chronometer Time and Greenwich Time. At sea the rate will be allowed for every day, and there is practically no difficulty in finding the correction of your Chronometer, provided, of course, it has a regular rate.

But in the Board of Trade Examination you will have to find out what the rate is, and the question is presented in a rather puzzling way. It may take something like the following form :

‘On August 23rd, 1898, A.M., Chronometer showed 8 h. 32 m. 17 s.’; and it may go on to say that ‘On May 7, 1898, the Chronometer was 3 m. 47 s. fast of M. T. G., and on November 13th, 1897, it was 1 m. 16 s. slow of M. T. G.’ What you would be required to discover is how much fast or slow on M.T.G. your Chronometer was on August 23. Proceed as follows :

Take the last date on which the difference of the Chronometer was ascertained. On May 7th it was 3 m. 47 s. fast; apply that to the time shown by the Chronometer :

$$\begin{array}{r} 8^{\text{h}} \ 32^{\text{m}} \ 17^{\text{s}} \\ - \ 3 \ 47 \\ \hline 8 \ 28 \ 30 \end{array}$$

So far so good; you have reduced the date for the error known to exist on May 7th, but what about the unknown error that has accrued since May 7th—in other words, what is the Chronometer rate? Well, on November 13th, 1897, it was 1 m. 16 s. slow, and on May 7th, 1898, it was 3 m. 47 s. fast. It has obviously, therefore, gained 5 m. 3 s., because 1 m. 16 s. + 3 m. 47 s. = 5 m. 3 s.

The Chronometer has gained 5 m. 3 s. in the interval. Of how many days was the interval composed?

November	.	.	13 days
December	.	.	31 „
January	.	.	31 „
February	.	.	28 „
March	.	.	31 „
April	.	.	30 „
May	.	.	7 „
			171 „

Your Chronometer has gained 5 m. 3 s. in 171 days. Turn 5 m. 3 s. into seconds and divide by the 171 days.

$$\begin{array}{r}
 5^m 3^s \\
 60 \\
 \hline
 171 \) \ 303 \ (1.77 \text{ gain} \\
 \underline{171} \\
 1320 \\
 \underline{1197} \\
 1230
 \end{array}$$

that is to say, as nearly as possible 1.77 s. a day gaining is your Chronometer's rate.

Now the last date on which the Chronometer's difference was ascertained was on May 7th, and your sight was taken on August 23. How many days have elapsed?

May	.	.	24 days
June	.	.	30 „
July	.	.	31 „
August	.	.	23 „
			108 „

108 days have elapsed; therefore the rate for one day multiplied by 108 days will give you what your Chronometer has gained in the interval since May 7th.

$$\begin{array}{r}
 108 \\
 1.77 \\
 \hline
 756 \\
 756 \\
 108 \\
 \hline
 60) 191.16 \ (3^m 11.16^s (3^m 11^s \text{ is of course near enough}) \\
 \underline{180} \\
 11
 \end{array}$$

3m. 11s. is what is called the accumulated rate, that is what your Chronometer has gained since its difference with Greenwich Time was last ascertained, namely on May 7th.



THIS PAGE IS LOCKED TO FREE MEMBERS

Purchase full membership to immediately unlock this page

DELVE INTO FANTASY, MAGIC, MYTHOLOGY & FOLKLORE

Forgotten Books'
Full Membership gives
access to 797,885 ancient
and modern, fiction and
non-fiction books.

Continue

*Fair usage policy applies

Having explained all the processes of the Longitude by Sun and Chronometer problem, let us work a few examples, and not particularly easy ones. In the first two examples every process is worked out separately; subsequently the work is done in the way it should be done in practice or in the examination room, with the subsidiary calculations on the left-hand margin of the paper. In real practice at sea you should not bother about decimal places, for it is absurd to waste time and trouble in calculating to great accuracy the results of observations which are bound to be inaccurate; but it is well to accustom yourself to decimals, and in the examination room accuracy to at least one place of decimals is desirable and necessary. But before working the examples, I will repeat the elements necessary, and the formula, for repetition is often useful. The elements you require are:

The correct Greenwich Date of your sights (found by correcting the time shown on your Chronometer); the correct Declination (found by correcting the Declination, taken out of the Nautical Almanac, for the time of sights from Greenwich Noon); the True Altitude (found by correcting the Observed Altitude); the Latitude (found by Dead Reckoning); the Polar Distance (found from the Declination); the correct Equation of Time (found by correcting the Equation taken out of the Almanac for the time of sights from Greenwich Noon).

The formula is $\text{Altitude} + \text{Latitude} + \text{Polar Distance} = \text{the sum}$. $\text{The sum} \div 2 = \text{the half sum}$. $\text{The half sum} - \text{the Altitude} = \text{Remainder}$. Then $\text{Log. Sec of Latitude} + \text{Log. Cosec of Polar Distance} + \text{Log. Cosine of half sum} + \text{Log. Sine of Remainder}$ gives you the $\text{Log. of the Sun's Hour Angle}$.

If the Sun is West of the Meridian (afternoon), the Hour Angle is a Westerly Angle, and is Apparent Time at

Ship. If the Sun is East of the Meridian (forenoon), the Hour Angle is an Easterly Angle, and must be converted into a Westerly Hour Angle by taking it from 24 hours and setting the date back a day. To the Westerly Hour Angle (Apparent Time at Ship) apply the Equation of Time, and so get Mean Time at Ship. To Mean Time at Ship apply Mean Time at Greenwich (derived from the Chronometer), and the Difference is Longitude in Time West if Greenwich Time is greater than Ship Time, East if Greenwich Time is less than Ship Time. Turn time into arc and you have the Longitude. Be sure and remember that the Equation of Time is *always* to be applied to the Sun's *Westerly* Hour Angle.

In the following examples and throughout this book problems are worked to the greatest accuracy, up to three or four places of decimals in the corrections, but please remember that such accuracy is absurd in practice, and is not required by the Board of Trade ; it is necessary in order to avoid confusion in the mind of the student when comparing the data in the problem with the Nautical Almanac.

Example I.—On March 18th, 1898, at about 8 h. 10 m. A.M., in Latitude $37^{\circ} 20' N$ and Longitude (D. R.) $178^{\circ} 50' E$, a Chronometer, showed 8 h. 28 m. 19 s. ; the Chronometer was 1 m. 27 s. slow on M. T. G. on October 10th, 1897 ; and it was 3 m. 15.5 s. fast on M. T. G. on January 31st, 1898. The Observed Altitude of the Sun's Lower Limb was $24^{\circ} 27' 30''$. Index Error + $1' 30''$, Height of the Eye 18 feet. Required the Longitude by Chronometer.

(a) In order to make sure what date the Chronometer was showing in this case, it is advisable to find a rough Greenwich Date by applying the Longitude in Time to the approximate Ship Time.

Approximate Ship Time March 18th	.	8 ^h 10 ^m	0 ^s	A.M.
Approximate Ship Time March 17th	.	20	10	0
Longitude in Time	.	11	55	20 E
Approximate Greenwich Time March 17th		8	14	40

The Chronometer was therefore obviously showing March 17th, 8 h. 28 m. 19 s.

(b) To find the exact Mean Time at Greenwich from the Time as shown on the Chronometer.

1st. Ascertain the rate from the knowledge you have that on October 10th, 1897, the Chronometer was 1 m. 27 s. slow, and on January 31st, 1898, it was 3 m. 15.5 s. fast.

In October	.	.	21 days
„ November	.	.	30 „
„ December	.	.	31 „
„ January	.	.	31 „
October 10th, 1897, to	}		<u>113</u> „
January 31st, 1898			

On October 10th, 1897, the Chronometer was	.	1 ^m 27 ^s slow
„ January 31st, 1898, „ „ „	.	<u>3 15.5 fast</u>
The Chronometer gained in the interval of 113 days	.	4 42.5
		<u>60</u>
		282.5 seconds

Therefore $282.5^s \div 113 =$ Chronometer's Daily Rate

$$\begin{array}{r} 113 \overline{) 282.5} \quad (2.5 \\ \underline{226} \\ 565 \\ \underline{565} \end{array}$$

Chronometer's Daily Rate is 2.5 seconds gaining

2nd. Find the amount the Chronometer gained from January 31st to March 17th, the date of sights.

January 31st to February 28th	=	28	days
February 28th to March 17th at 8 ^h	=	17	„
Total interval	=	<u>45</u>	„
Daily Rate	=	<u>2.5</u>	„
		225	
		90	
		<u>60</u>	
		112.5	

Accumulated Rate = 1^m 52.5^s gained

3rd. Correct the Chronometer Time.

Chronometer showed	.	.	8 ^h 28 ^m 19 ^s
Error on January 31st, 1898			<u>- 3 15.5 fast</u>
			8 25 3.5
Accumulated Rate	.	.	<u>- 1 52.5 gained</u>
M.T.G. on March 17th	.	.	8 23 11

(c) To correct the Sun's Declination and the Equation of Time. For convenience sake express the Greenwich



THIS PAGE IS LOCKED TO FREE MEMBERS

Purchase full membership to immediately unlock this page

SAVE \$3,999,994

Did you know we sell
paperback books too?

To buy our entire catalog
in paperback would cost
over \$4,000,000

Access it all now for
\$8.99/month

*Fair usage policy applies

Continue

Example II.—On June 22nd, 1898, at about 4 h. 45 m. P.M. in Latitude $53^{\circ} 47' N$, and Longitude (D. R.) $179^{\circ} 50' E$, the Chronometer showed 4 h. 41 m. 19 s. The Chronometer was on March 31st, 1898, 10 m. 18 s. slow of M. T. G.; and on June 1st it was 10 m. 49 s. slow of M. T. G.; the Observed Altitude of the Sun's Lower Limb was $28^{\circ} 32' 0''$. Index Error— $1' 40''$, Height of Eye 29 feet. Required the Longitude by Chronometer.

Hitherto we have used intervals composed of whole days, but it may be that the interval between dates at which your Chronometer's error was ascertained would consist of so many days and so many hours. In such a case turn the hours into decimals of a day, as is shown in this example.

(a) To find Approximate Greenwich Date.

Ship Time on 22nd	. . .	4 ^h 45 ^m 0 ^s	P.M.
Longitude in Time . . .		11 59 20	East
Approximate Greenwich Date 21st		16 45 40	

Obviously the Chronometer was showing 4^h 41^m 19^s A.M. on the 22nd.

(b) To find accurate M. T. G. from Chronometer.

Error on March 31st . 10^m 18^s slow
 „ June 1st . 10 49 „

Lost in interval . . 0 31

March 31st to April 30th . 30 days

April 30th to May 31st . 31 „

May 31st to June 1st . 1 day

Total Interval . . . 62 days

62) 31^s (.5 daily rate losing

June 1st to 21st = 20 days

17^h . = .7 of a day

20.7 days

Daily rate5

Accumulated rate . 10.4^s lost

Chronometers showed 4^h 41^m 19^s
 Error on June 1st . + 10 49 slow

4 52 8

Accumulated Rate . + 10 lost

4 52 18 A.M. on 22nd

Greenwich Date on } 12
 June 21st } 16 52 18

(c) To Correct the Sun's Declination and the Equation of Time.

Var. in Dec. in 1 hour	1·1''	Var. in E. T. in 1 hour	·543°
T, of sights from Noon	7·1		7·1
	<u>11</u>		<u>543</u>
	77		3801
Correction . . .	7·81	Correction . . .	3·8553

	Sun's Dec.		E. T.
Dec. Noon 22nd . . .	23° 26' 56·4''	E. T. Noon 22nd	1 ^m 43·7°
Correction . . .	7·8''	Correction . . .	3·9
At Time of Obs. . .	<u>23° 27' 4'' N</u>	E. T. at T. of Obs.	1 39·8 + on A. T.
Pol. Dist. . . .	66° 32' 56'		

(d) Correct the Observed Altitude and so find True Altitude.

Obs. Alt. ☉ . . .			28° 32' 0''
I. E.			<u>-1' 40''</u>
			28° 30' 20''
Dip 29 ft. . . .			<u>5' 16''</u>
			28° 25' 4''
☉ Semi-Diameter . . .			<u>15' 46''</u>
App. Alt.			28° 40' 50''
Refraction			<u>1' 44''</u>
			28° 39' 6''
Parallax			<u>8''</u>
Tr. Alt.			28° 39' 14''

(e) To calculate the Sun's Hour Angle and thence the Longitude.

Alt.				
Lat.	28° 39' 14''			
P. D.	53° 47' 0''	Log. Sec	·228530	
	66° 32' 56''	Log. Cqsec	·037442	
Sum	<u>2) 148° 59' 10''</u>			
½ sum	74° 29' 35''	Log. Cos	9·427089	
Remainder	45° 50' 21''	Log. Sin	9·855754	
		4 ^h 52 ^m 1 ^s = Log. H. A.	9·548815	

☉ H. A. West or A. T. S. 22nd			4 ^h 52 ^m 1 ^s
Equation of Time			<u>+ 1 40</u>
M. T. S. 22nd			4 53 41
M. T. G. 21st			<u>16 52 18</u>
Long. in Time			12 1 23 East
„ Arc			180° 20' 45'' E
			<u>360° 0' 0''</u>
Longitude			179° 39' 15'' W

Example III.—On October 19th, A.M. at Ship, in Latitude $50^{\circ} 12' N$, when the Time by a Chronometer was on October 18th, 20 h. 51 m. 17 s. Correct M.T.G., the Observed Altitude of the Sun's Lower Limb was $18^{\circ} 42' 0''$, Index Error $+ 1' 20''$, Height of the Eye 14 feet. Required the Longitude by Chronometer.

Subsidiary calculations for correction of Dec. and E. T.		M. T. G. October 18th 20 ^h 51 ^m 17 ^s			
		Dec. on 19th	. $10^{\circ} 5' 50.5'' S$	E. T. 19th	. $14^m 59.3^s$
		Correction	. $2' 50.6''$	Correction	. 1.4
		Cor. Dec.	. $10^{\circ} 3' 0'' S$	Cor. E. T.	. $14 57.9$
		P. D.	. $100^{\circ} 3' 00''$		
		Obs. Alt. \odot	$18^{\circ} 42' 0''$		
		I. E.	$+ 1' 20''$		
			<hr/>		
		Dip	$3' 40$		
			<hr/>		
		\odot S.-D.	$16' 6''$		
		App. Alt.	$18^{\circ} 55' 46''$		
		Ref.	$2' 45''$		
			<hr/>		
		Par	$8''$		
		Tr. Alt.	$18^{\circ} 53' 9''$		
		Alt.	$18^{\circ} 53' 9''$		
		Lat.	$50^{\circ} 12' 0''$	Log. Sec	$.193746$
		P. D.	$100^{\circ} 3' 0''$	Log. Cosec	$.006716$
		Sum	$2) 169^{\circ} 8' 9''$		
		$\frac{1}{2}$ sum	$84^{\circ} 34' 4''$	Log. Cos	8.976205
		Remainder	$65^{\circ} 40' 55''$	Log. Sin	9.959649
				<hr/>	
				$2^h 53^m 42^s =$	Log. H. A. 9.136316
		\odot H. A. East	$2^h 53^m 42^s$		
			$24 0 0$		
		\odot H. A. West or A. T. S. 18th	$21 6 18$		
		E. T.	$- 14 58$		
			<hr/>		
		M. T. S. 18th	$20 51 20$		
		M. T. G. 18th	$20 51 17$		
			<hr/>		
		Long. in Time	$0 0 3$		
				Longitude $0^{\circ} 0' 45'' E$	

Example IV.—On September 23rd, 1898, A.M., at Ship, in Latitude $49^{\circ} 28' S$, when a Chronometer showed Sep-



THIS PAGE IS LOCKED TO FREE MEMBERS

Purchase full membership to immediately unlock this page

DELVE INTO FANTASY, MAGIC, MYTHOLOGY & FOLKLORE

Forgotten Books'
Full Membership gives
access to 797,885 ancient
and modern, fiction and
non-fiction books.

Continue

*Fair usage policy applies

required, it is necessary to know how to find the Log. of an Hour Angle and how to find the Hour Angle of a Log. which exceed the limits of the Tables.

To find the Log. of an Hour Angle which exceeds the limits of Table XXXI.—1st, turn Time into Arc ; 2nd, halve the Arc ; 3rd, take out the Log. Sine of half the Arc from Table XXV. ; 4th, double this Log. Sine. The result is the Log. required.

To find the Hour Angle corresponding to a Log. which exceeds the limits of Table XXXI.—1st, halve the Log. ; 2nd, take out the angle of which this halved Log. is the Log. Sine from Table XXV. ; 3rd, double the angle and convert it into time. The result is the Hour Angle required.

That, I think, is all there is to be said about finding Latitude and Longitude by the ordinary means. At sea the customary way of fixing your position at Noon is to take a forenoon sight of the Sun when it is as nearly as possible on the Prime Vertical. The object of taking it when East or as nearly East as possible, is that when the Sun is in that position, a considerable error in Latitude, amounting to 10', or even more, creates no appreciable error in Time. Work your A.M. sight with the best Latitude you have, either with a Latitude derived by Dead Reckoning from the preceding Noon, or from any reliable Latitude taken later—the less you have to do with Dead Reckoning the better, for even in the best regulated families it is uncertain. Find your Latitude at Noon by Meridian Altitude of the Sun ; ascertain the Difference of Latitude and Difference of Longitude due to the run of the ship between A.M. sights and Noon. Apply the Difference of Latitude backwards to see if the Latitude used for your A.M. sight was correct. If you find it incorrect you must either work your Chronometer sight

over again with the correct Latitude or you must fall back upon Johnson's or some other Tables; then bring your Longitude at A.M. sights up to Noon, by applying the Difference of Longitude due to the run of the ship, and with that and the Latitude by Meridian Altitude you have the ship's position at Noon.

Mr. A. C. Johnson supplies you, in 'How to find the time at sea in less than a minute,' with a simple method of ascertaining the error of Longitude due to an error in Latitude, which saves you all the trouble of working your A.M. sight over again.

To use Johnson's Tables : find the Sun's Azimuth at the time of your A.M. sight, by using the Hour Angle, found from your sight and Burdwood or Davis' Tables as hereafter described; or you may find Apparent Time at Ship from your Chronometer Time, or you may get the Sun's Bearing by Compass corrected for Compass Error. Enter Table E with Latitude at the top and True Azimuth on the side, and take out the corresponding number, which is the error of Longitude in minutes and decimals of a minute of arc due to one minute of arc error in Latitude. Multiply your ascertained error in Latitude by the number taken out of the Tables, and you have the error in Longitude.

To know how to apply the error: draw on any bit of paper a line representing your Parallel of Latitude, and mark with a dot your approximate position. From this dot draw a line roughly in the direction of the Sun's True Bearing, and through the dot draw a line at right angles to the line of the Sun's Bearing; this is called the Line of Position, and the ship must be somewhere on it. You know whether your incorrect Latitude was too much to the North or too much to the South, and the figure shows at once whether the correction of

Longitude is to be applied to the Eastward or to the Westward. Thus :

FIG. 56

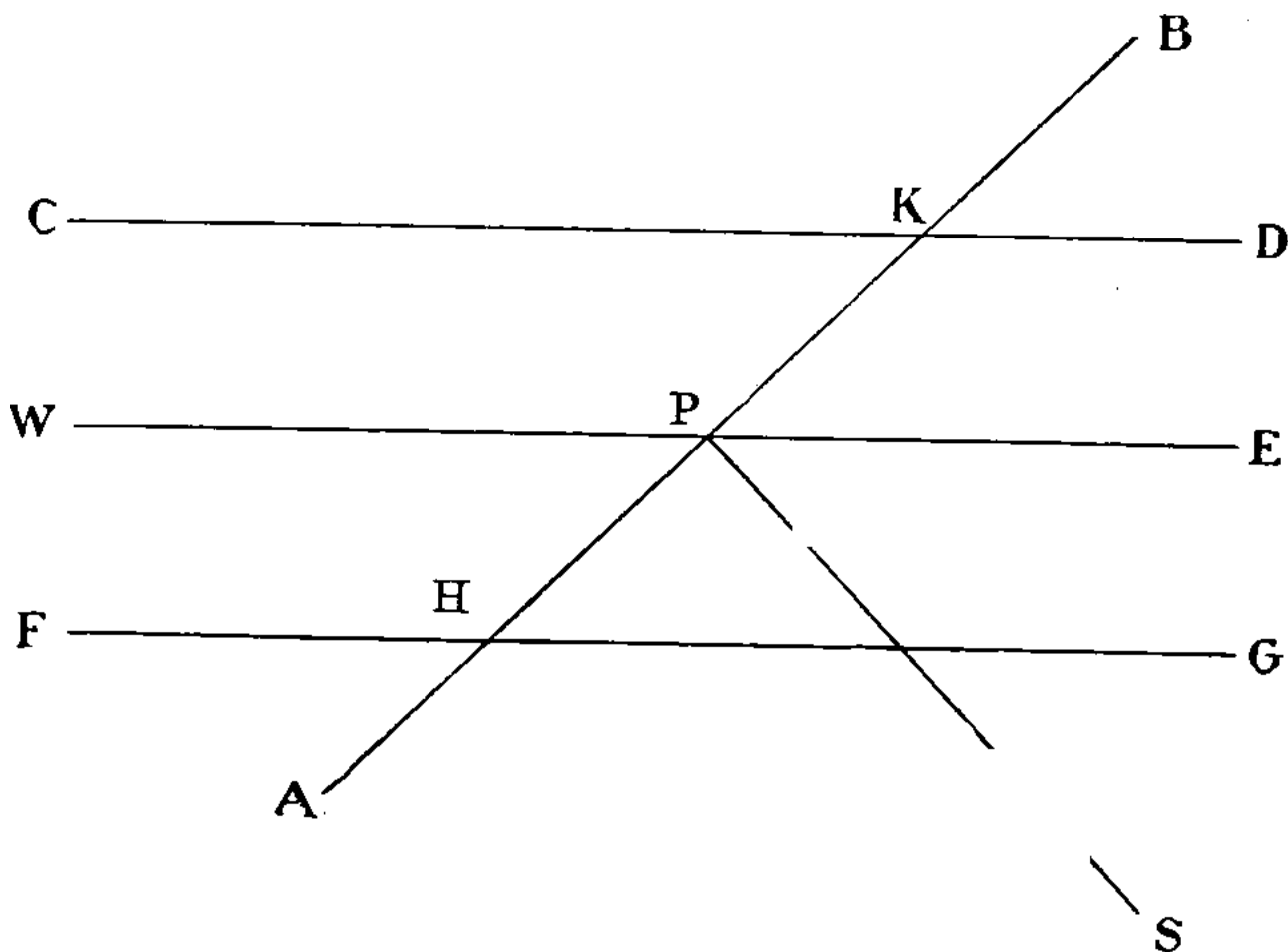

Let WE be a Parallel of Latitude, and P the position of the ship derived from your A.M. sight worked with that Latitude. Let PS represent the line of the Sun's Bearing. AB , at right angles to it, is the Line of Position somewhere upon which the Ship must be. Let the lines CD and FG be Parallels say $10'$ on either side of WE . If the Latitude used in working your A.M. sight was correct your ship would be at P . If it was incorrect, and was say $10'$ too much to the Northward, the Ship's position must be at H , and the correction of Longitude obviously is to be applied to the Westward. If on the contrary the Latitude was say $10'$ too much to the Southward, the position of the Ship must be at K , and the correction of Longitude is to be applied to the Eastward. Having corrected your Longitude, then to the corrected Longitude at A.M. sights apply the Difference of Longitude due to the run of the Ship, and you have your Longitude at Noon. Lines of Position



THIS PAGE IS LOCKED TO FREE MEMBERS

Purchase full membership to immediately unlock this page

SAVE \$3,999,994

Did you know we sell
paperback books too?

To buy our entire catalog
in paperback would cost
over \$4,000,000

Access it all now for
\$8.99/month

*Fair usage policy applies

Continue

D. R. at 8.30 A.M. in order to obtain a Lat. to use in working out the observation taken at that time to find the Long.; and here it is:

To ascertain position of Ship by Dead Reckoning at 8.30 A.M. on August 19th.

<i>First Course</i>			True Course	Dist.	Diff. Lat.		Departure	
ENE	Leeway	Dev.			N	S	E	W
N 67½° E	5½° E	6° E						
			N 56° E	43.0	24.0	—	35.6	—
Var. . . . N 79° E	23° W		N 53½° E	17.0	10.1	—	13.7	—
			N 50½° E	27.0	17.2	—	20.8	—
True Course. N 56° E			N 51½° E	54.5	33.9	—	42.6	—
			N 62° E	27.3	12.8	—	24.1	—
					98.0		136.8 = Diff. Long.	238.5
<i>Second Course</i>								
ENE	Leeway	Dev.						
N 67½° E	3° E	6° E						
Var. . . . N 76½° E	23° W							
True Course. N 53½° E								
<i>Third Course</i>								
ENE	Dev.							
N 67½° E	6° E							
Var. . . . N 73½° E	23° W							
True Course. N 50½° W								
<i>Fourth Course</i>								
ENE	Dev.							
N 67½° E	6° E							
Var. . . . N 73½° E	22° W							
True Course. N 51½° E								
<i>Fifth Course</i>								
E b N	Dev.							
N 79° E	5° E							
Var. . . . N 84° E	22° W							
True Course. N 62° E								

Lat. Left . . .	54° 26' N	Long. Left . . .	30° 14' W
Diff. Lat. . . .	1° 38' N	Diff. Long. . . .	3° 58' 30" E
Lat. D. R. . . .	56° 4' N	Long. D. R. . . .	26° 15' 30" W

The Course and Distance made good to 8.30 A.M. is, by the Traverse Table, entered with 98.0 Diff. Lat. and 138.8 Dep., as nearly as possible N 55° E 170 miles.

The second step is to find the Long. by working a Sun Chron., using the Lat. D. R. just calculated. Here is the problem re-stated from the Log:

1898, August 19th, A.M. at ship, in Lat. D. R. $56^{\circ} 4' N$, when the time by Chron. was on the 18th 22 h. 17 m. 30 s., whose error on M.T.G. was slow 1 m. 23 s., the Obs. Alt. \odot was $31^{\circ} 0' 0''$, I.E. $-1' 15''$, Height of the Eye 18 feet. Required the Long.

<p>Dec. Var. in 1^h $49.14''$ 1.7 <hr/>34398 4914 <hr/>60) 83.538 <hr/>1' 23.5''</p> <p>E. T. Var. in 1^h $.57^{\circ}$ 1.7 <hr/>.969</p>	<p>Time by Chron. $10^h 17^m 30^s$ Error . . . 1 23 <hr/>M. T. G. on 18th 22 18 53</p> <p>Obs. Alt. . $31^{\circ} 0' 0''$ I. E. . $-1' 15''$ <hr/>$30^{\circ} 58' 45''$ Dip . . $4' 11''$ <hr/>$30^{\circ} 54' 34''$ S. D. . $15' 50''$ <hr/>$31^{\circ} 10' 24''$ R. - P. . $1' 29''$ <hr/>$31^{\circ} 8' 55''$ Tr. Alt. . $31^{\circ} 8' 55''$ Lat. . $56^{\circ} 4' 0''$ P. D. . $77^{\circ} 16' 50''$ <hr/>$2) 164^{\circ} 29' 45''$ <hr/>$82^{\circ} 14' 52''$ <hr/>$51^{\circ} 5' 57''$</p>	<p>August 19th $12^{\circ} 41' 46.8'' N$ $1' 23.5''$ <hr/>Corr. Dec. $12^{\circ} 43' 10'' N$ $90^{\circ} 0' 0''$ <hr/>\odot P. D. . $77^{\circ} 16' 50''$</p> <p>E. T. August 19th $3^m 25.62^s$ $.97$ <hr/>Corr E. T. . 3 26.59</p> <p>Sec . .253189 Cosec .010790</p> <p>$\cos . 9.129978$ $\sin . 9.891110$ <hr/>Log. H. A. $9.285067 = 3^h 28^m 21^s$</p> <p>A. T. S. 18th $20^h 31^m 39^s$ E. T. + 3 27 <hr/>M. T. S. 18th 20 35 6 M. T. G. 18th 22 18 53 <hr/>Long. in T. . 1 43 47 = $25^{\circ} 56' 45''$</p> <p>Therefore the Long. at $8^h 30^m$ A.M. using Lat. $56^{\circ} 4'$ is $25^{\circ} 56' 45'' W$</p>
---	---	---

The next proceeding is to take out of Burdwood's Tables the True Azimuth of the Sun at the time of sights.

Entered with Lat. $56^{\circ} N$, Dec. $12\frac{3}{4}^{\circ} N$, and A. T. S. 8 h. 32 m. A.M., Burdwood's Tables give as the True Azimuth $N 116^{\circ} E = S 64^{\circ} E$

The next operation is to bring the D. R. position of the ship up to Noon on the 19th, by working a little Traverse from 8 h. 30 m. A.M.

E b N	. N 79° E	Distance run from 8 ^h 30 ^m A.M. to Noon is 41.2
Dev.	. 5° E	
	<u>N 84° E</u>	
Var.	. 22° W	
Tr. Course	N 62° E	<i>By Traverse Table</i>
		N 62° E 41.2' 19.3' N 36.4' E = Diff. Long. 65'
		At 8 ^h 30 ^m A.M. Lat. D.R. 56° 4' Long. D.R. 26° 15' 30'' W
		Diff. Lat. 19' 18'' N Diff. Long. 1° 5' 0'' E
		At Noon Lat. D.R. 56° 23' 18'' N Long. D.R. 25° 10' 30'' W

Now to find the Lat. by the Mer. Alt. of the Sun. Here is the problem stated :

1898, August 19th, in Long. D. R. 25° 10' 30'' W, the Obs. Mer. Alt. ☉ bearing South was 46° 15' 50'', I. E. -1' 15'', Height of Eye 18 feet. Required the Lat.

49.14'	A.T.S. 19th 0 ^h 0 ^m 0 ^s	Obs. Alt. 46° 15' 50''	
1.7	Long. in T. 1 40 42	I. E. . -1' 15''	☉ Dec.
<u>34398</u>	A.T.G. 19th 1 40 42	46° 14' 35''	12° 41' 46.8'' N
4914		Dip . 4' 11''	1' 23.5''
60) <u>83.538</u>		46° 10' 24''	12° 40' 23'' N
1' 23.5''		S.-D. . 15' 50''	
		46° 26' 14''	
		R.-P. . 49''	
		Tr. Alt. . 46° 25' 25'' S	
		90° 0' 0''	
		Z. D. . 43° 34' 35'' N	
		Dec. . 12° 40' 23'' N	
		<u>Lat. by Mer. Alt. 56° 14' 58'' N</u>	

Now to ascertain whether the Lat. used at A.M. sights was correct. Apply the Diff. Lat. due to Course and Dist. from 8 h. 30 m. A.M. to Noon reversed.

Lat. by Obs. at Noon	. 56° 14' 58'' N
Diff. Lat. (run of ship)	19' 18'' S
Lat in at 8 ^h 30 ^m	. 55° 55' 40'' N
Lat. used	. 56° 4' 0'' N
Error of Lat.	. 0° 8' 20'' too much to the Northward

To find by Johnson's Tables the error of Long. due to 8.33' error of Lat.

Entered with Lat. 56° and Bearing 64° the Table gives .87' as the error in Long. corresponding to 1' error in Lat.,



THIS PAGE IS LOCKED TO FREE MEMBERS

Purchase full membership to immediately unlock this page

DELVE INTO FANTASY, MAGIC, MYTHOLOGY & FOLKLORE

Forgotten Books'
Full Membership gives
access to 797,885 ancient
and modern, fiction and
non-fiction books.

Continue

*Fair usage policy applies

You might possibly enter on the Log, if you prided yourself on the accuracy of your Dead Reckoning, that 'a current set the ship ten miles North-westerly.'

Now perhaps you might like to know something of the nature of the problem you have worked; but don't trouble yourself about the matter unless you feel so inclined.

FIG. 58

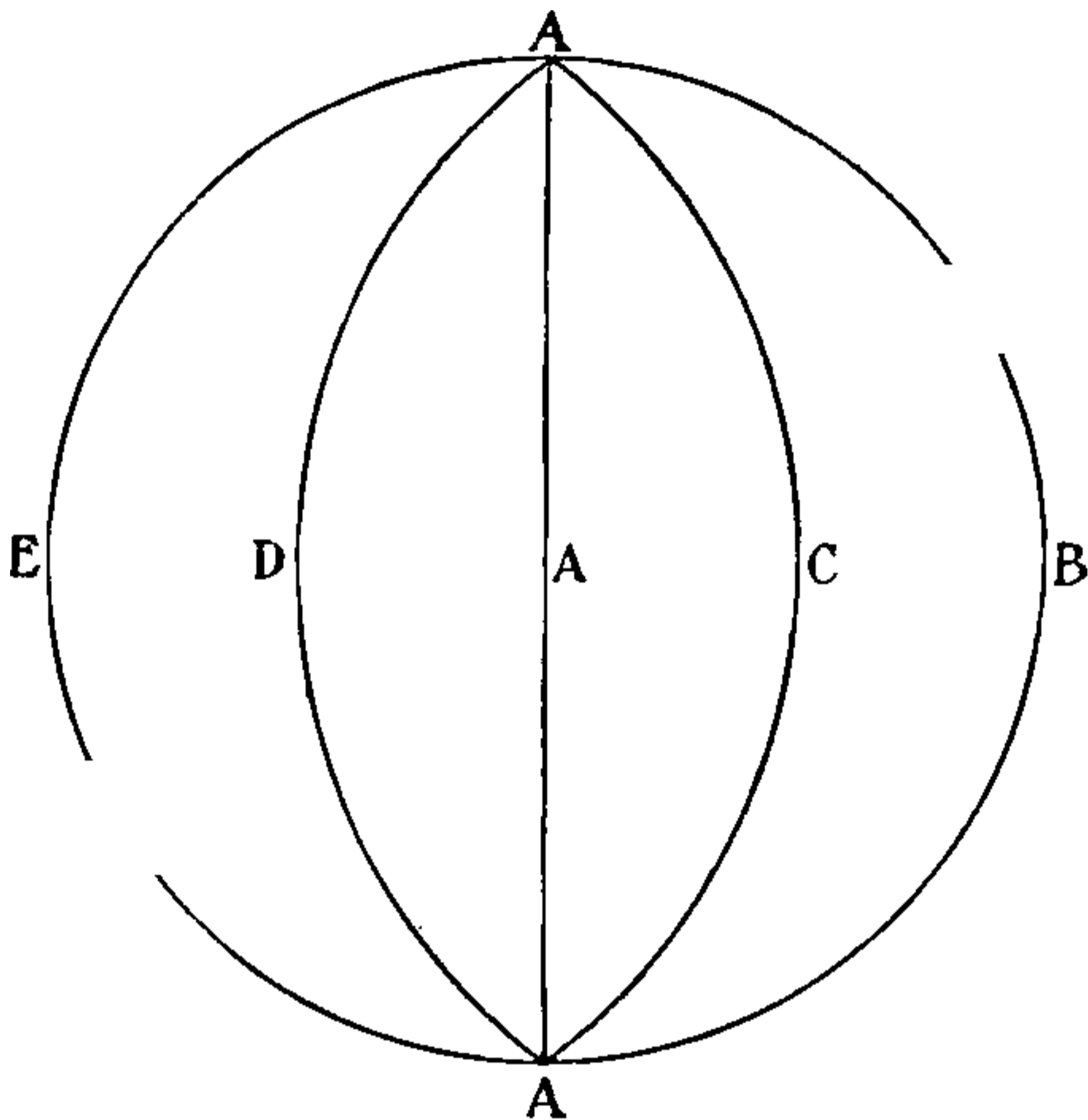

Fig. 58 is supposed to represent half the Globe, a hemisphere; AA is the Meridian of an observer at Greenwich. ACA , ABA , ADA , AEA are other Meridians. Suppose you are taking the Sun's Time at Greenwich. When the Sun is on the Meridian ABA it will be 6 o'clock in the forenoon, when it is on the Meridian ACA it will be 9 o'clock in the forenoon, when it is on the Meridian AAA it will be Noon, when it is on the Meridian ADA it will be 3 o'clock in the afternoon, and when it is on the Meridian AEA it will be 6 in the afternoon, and so on round the other side of the sphere, 9 in the afternoon, midnight, and 3 in the morning. It will be obvious from this that Time is the angle which the

Sun makes at the North Pole of the Earth. At 6 A.M. it makes the angle $\widehat{A A B}$ East; at 9 A.M. it makes the angle $\widehat{A A C}$ East; at noon it makes no angle; at 3 P.M. it makes the angle $\widehat{A A D}$ West; at 6 P.M. it makes the Angle $\widehat{A A E}$ West, and so on and so on.

Solar Time, therefore, is the Polar Angle of the Sun, and that angle is usually called the Horary, or Hour Angle.

FIG. 59

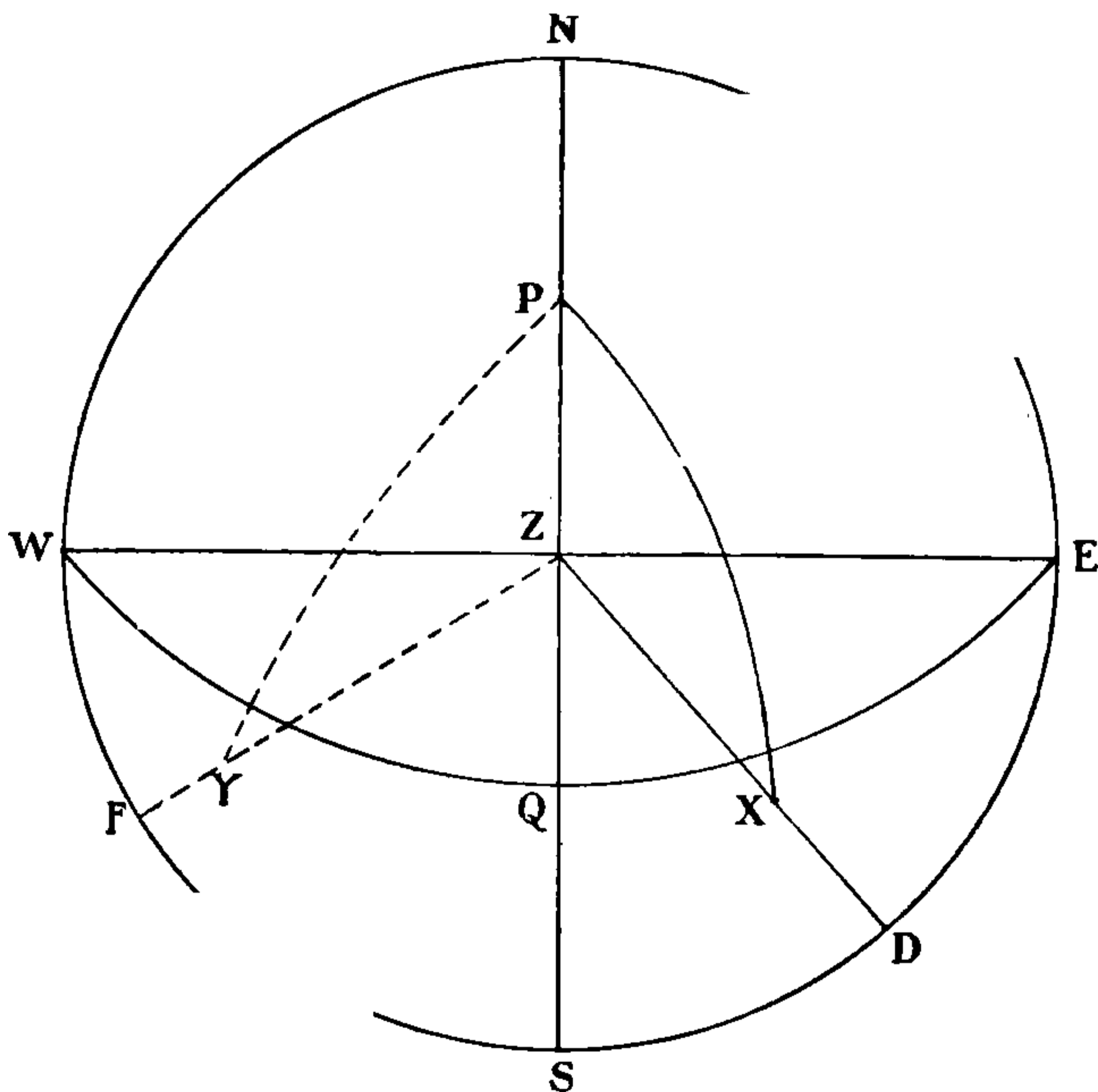
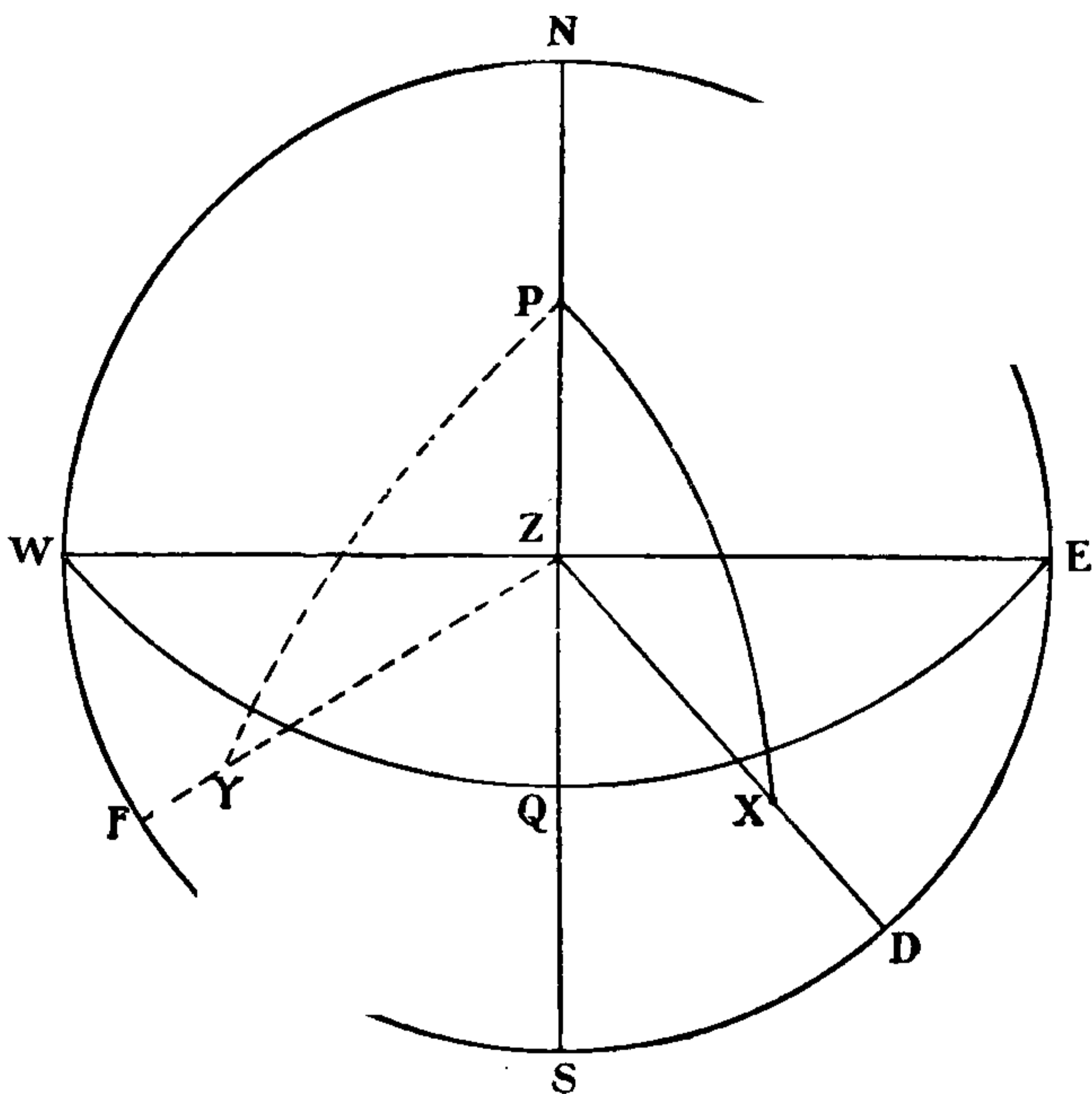

Fig. 59 is drawn on the plane of the Horizon. Let ns be the Meridian of the observer, P being the elevated Pole (the North Pole in North Latitude), z the Zenith of the observer; wqe the Equator; x the position of the Sun. Then xd is the True Altitude of the Sun, found by the sextant, and zx is his Zenith Distance; zq is the Latitude. As the angular distance of the Equator from the Pole is 90° , if you deduct the

Latitude from 90° you get the Colatitude, Pz . Also, as the Equator is 90° from the Pole, $90^\circ +$ the Declination if the Declination is South, or $90^\circ -$ the Declination if the Declination is North, gives the Polar Distance of the Sun Px ; by finding the True Altitude of the Sun and his Polar Distance, and knowing your Latitude, you know the three sides Px , Pz , zx of the triangle zPx which are

FIG. 59



the Polar Distance, Colatitude, and Zenith Distance respectively. The angle at $P =$ the Angle zPx is the Sun's Hour Angle East, and, deducted from 24 hours it is Apparent Time at Ship Astronomical Time. The dotted lines represent the position with the Sun West of the Meridian. The angle at the Pole zPy is the Hour Angle West = Apparent Time at Ship.

If you know the three sides of any spherical triangle



THIS PAGE IS LOCKED TO FREE MEMBERS

Purchase full membership to immediately unlock this page

SAVE \$3,999,994

Did you know we sell
paperback books too?

To buy our entire catalog
in paperback would cost
over \$4,000,000

Access it all now for
\$8.99/month

*Fair usage policy applies

Continue

To find B you would deduct b from the half-sum and take out the Log. Cosecants of a and c .

To find A you would deduct a from the half-sum and take out the Log. Cosecants of b and c .

The object of remembering this formula is that the value of any angle in any spherical triangle of which the three sides are known can be found by it, and it is equally

FIG. 60

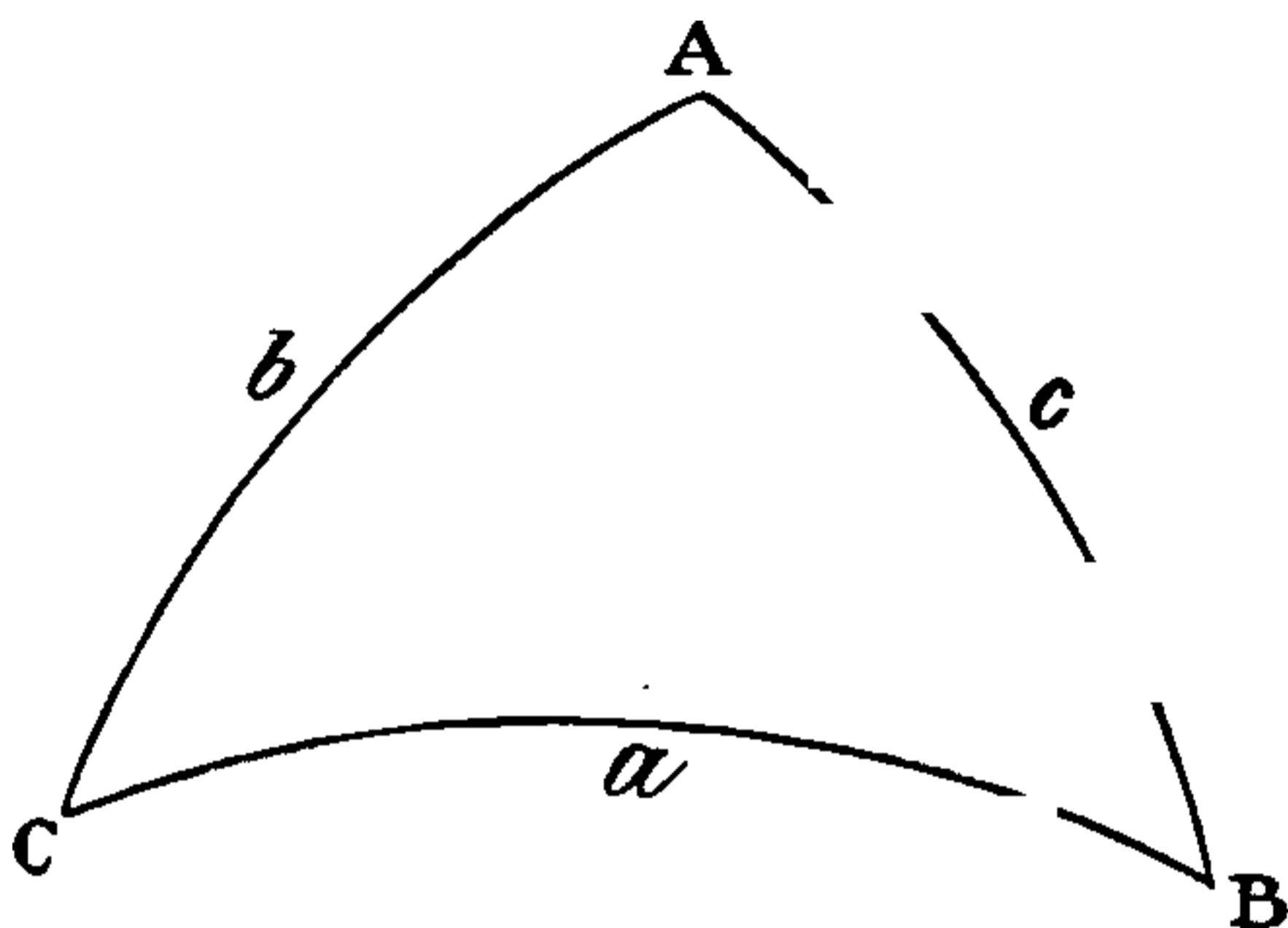

applicable to several other problems; but it does not offer the speediest method of finding the Sun's Hour Angle, and as speed is an object the formula already given and worked is generally used.

Should you be required in the Examination Room to draw a figure showing the nature of the problem and how the Hour Angle is found, draw a figure like No. 59, that is of course supposing you to be in North Latitude. If the problem assumes an observer in South Latitude the figure must be drawn as in fig. 61. For working the problem, it is really sufficient to show the three sides, namely PX (the Polar Distance), PZ (the Colatitude), and ZX (the Zenith Distance), and to state that the Angle at the Pole (P) is the Hour Angle required; but it is better to draw the whole figure complete, and showing approximately the

positions and Altitude of the Body observed. You will not be asked to explain how the working formula you use to find the Hour Angle is derived; but if you want to know you will find it deduced from the rigid formula at the end of Vol. II. The plain lines in figs. 59 (representing North Latitude) and 61 (representing South Latitude)

FIG. 61

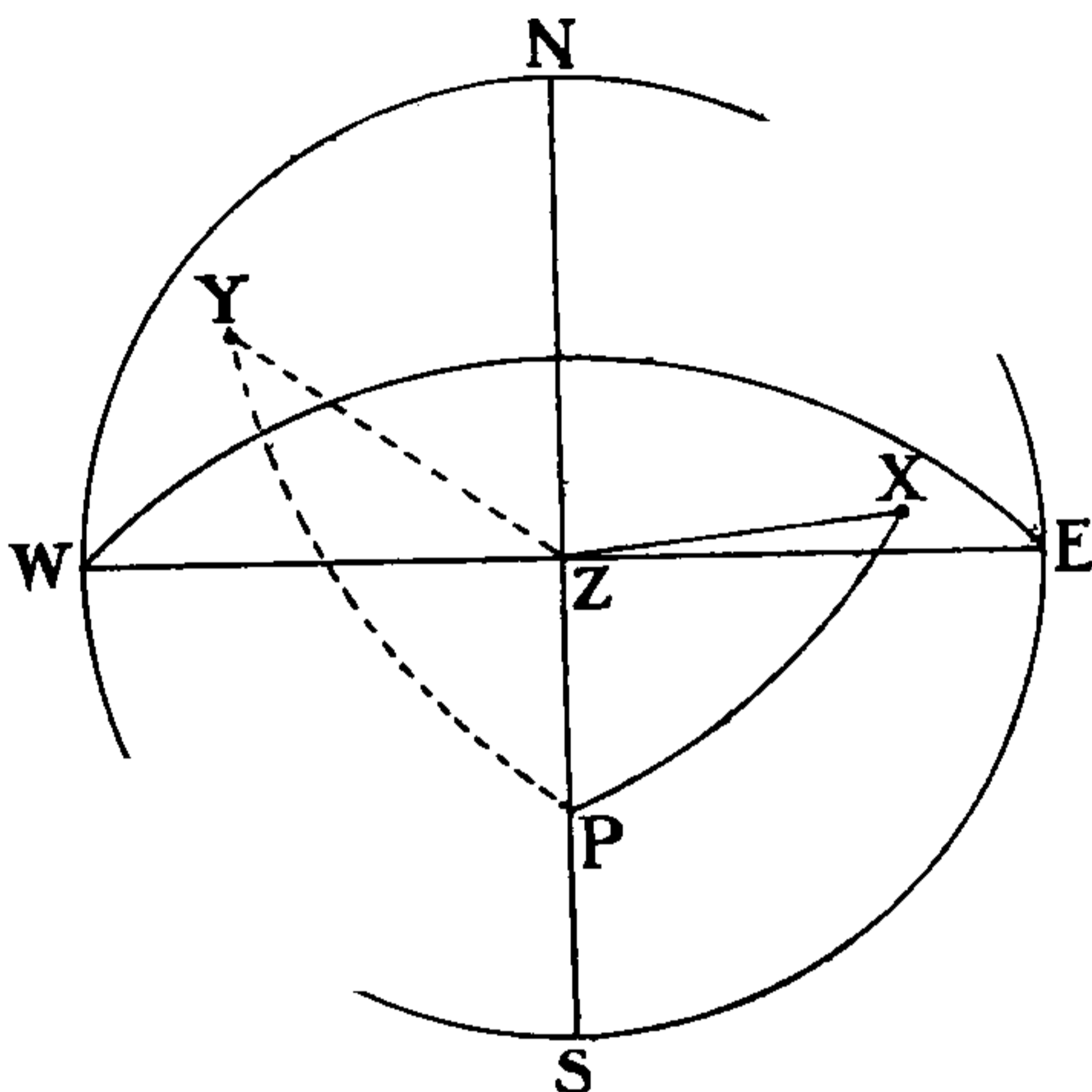

show an Easterly Polar Angle, the dotted lines a Westerly Polar Angle. Of course you will be careful in drawing a figure to make it in conformity with the problems you are illustrating.

So much for 'Longitude by Sun and Chronometer.' The converse of the problem is useful in practice, and will probably be given you in the Examination Room.

To find the error of the Chronometer by an Hour Angle, the Longitude being known.

I have shown how to find an unknown quantity—the Longitude, from a known Greenwich date; the converse problem consists of finding an unknown quantity—the error of the Chronometer, from a known Longitude. It is likely that in the Examination Room you will be asked to find your Chronometer's error by an Altitude of the Sun, the Longitude being given you, and the operation is one which you may frequently have to perform at sea.

In the problem we have just done you know your Latitude and the Greenwich date; you take the Declination and the Equation of Time out of the Almanac; you calculate Apparent Time at Ship and turn it into Mean Time, and by comparison with Mean Time at Greenwich, ascertained from your Chronometer, you find your Longitude in Time, and thence your Longitude in Arc. In the problem under consideration you know your Latitude and Longitude, you take Declination and Equation of Time out of the Almanac, you calculate Apparent Time at Ship, turn it into Mean Time at Ship, apply the known Longitude in Time to it, deducting if you are East of Greenwich, adding it if you are West of Greenwich, and so you get Mean Time at Greenwich. The difference, if any, between Mean Time at Greenwich so found and Mean Time at Greenwich as shown by your Chronometer is the error of the Chronometer.

The problem will probably be given you in this shape: you will be told that a rock, island, lighthouse or whatever it may be, in Latitude so and so, and Longitude so and so, bore in such and such a direction from you



THIS PAGE IS LOCKED TO FREE MEMBERS

Purchase full membership to immediately unlock this page

DELVE INTO FANTASY, MAGIC, MYTHOLOGY & FOLKLORE

Forgotten Books'
Full Membership gives
access to 797,885 ancient
and modern, fiction and
non-fiction books.

Continue

*Fair usage policy applies

--1' 40'', Height of Eye 32 feet. Required the Error of the Chronometer on M. T. G.

Bearing reversed S 20° W 5 miles; 20° and 5 miles = Diff. Lat. 4.7 Dep. 1.7. Dep. 1.7 in Lat. 56° = Diff. Long. 3'

Lat. Cape Horn	55° 59' S .	Long. Cape Horn	67° 16' W
Diff. Lat. . . .	4' 42'' S	Diff. Long. . . .	3'
Lat. in . . .	<u>56° 3' 42'' S</u>	Long. in . . .	<u>67° 19' W</u>

Dec.		© Dec.	E. T.
in. 1 ^h = 22''	A. T. S. 1st	19 ^h 20 ^m 0 ^s	Dec. 2nd 22° 0' 57.4''
.2	Long. in Time	4 29 16	Corr. 4.4''
<u>4.4</u>	A. T. G. 1st	<u>23 49 16</u>	Corr. Dec. <u>22° 0' 53'' S</u>
E. T.			Corr. E. T. 10
ar. in 1 ^h = 1 ^s			P. D. . . 67° 59' 7''
.2	Obs. Alt. ☉	29° 16' 0''	Tr Alt. . 29° 23' 31''
<u>.2</u>	I. E. . . .	<u>- 1' 40''</u>	Lat. . . 56° 3' 42''
		29° 14' 20''	P. D. . . 67° 59' 7''
	Dip 32 ft. . .	5' 32''	Sum . 2) 153° 26' 20''
		29° 8' 48''	½ sum . 76° 43' 10''
	☉ S.-D. . . .	16' 15''	Remainder 47° 19' 39''
	App. Alt . . .	29° 25' 3''	4 ^h 38 ^m 42 ^s =
	Ref.	1' 40''	Log. H. A. . 9.51
		29° 23' 23''	☉ H. A. 4 ^h 38 ^m 42 ^s East
	Par.	8''	<u>24 0 0</u>
	True Alt . . .	29° 23' 31''	A. T. S. 1st . . . 19 21 18
			E. T. - 10 21
			<u>19 10 57</u>
			Long. in T. . . . 4 29 16 W
			<u>23 40 13</u>
			M. T. G. 1st . . . 0 12 18
			Chron. Time . . .
			<u>0 32 5</u>
			Chron. fast on M. T. G.

The two problems, Latitude by a Meridian Altitude of the Sun and Longitude by a Sun Chronometer, are the mainstay of the ordinary Mariner, and though very deficient in navigational knowledge you would be able, with their help, to find your way about the world. But it is very essential also to be able to ascertain the Deviation of the Compass when at sea.

CHAPTER XIV

OBSERVATIONS USED FOR MAKING COMPASS
CORRECTION

UNLESS you desire to pile your ship up on a rock or sand-bank on the first favourable opportunity, you will not neglect any chance of ascertaining the Deviation of your Compass at sea by means of Amplitudes and Azimuths. The principle is the same in both cases. You take the Bearing of the Sun or some other Heavenly Body by Compass and note the direction of the ship's head—that is the Course you are steering, and you find by calculation the true Bearing of the Heavenly Body. By applying the Variation—which you will find on the chart, to the True Bearing, you get the Body's Correct Magnetic Bearing. The difference between the Correct Magnetic Bearing and the Compass Bearing is the Deviation of the Compass on the Course the ship is steering. Or put it this way: the difference between True Bearing and Bearing by Compass is the Error of the Compass; the error is composed of Variation and Deviation; allow for Variation, and the balance is Deviation.

To name the Deviation. If Correct Magnetic is to the right of Compass the Deviation is Easterly; if Correct Magnetic is to the left of Compass the Deviation is Westerly.

Amplitude

(A Second Mate must find the True Amplitude of the Sun, and being given the Variation, deduce the Compass Error and the Deviation.)

An Amplitude is the angle at the Zenith, or what is the same thing, the angular distance on the Horizon between a Body when rising or setting, and the Prime Vertical Great Circle; in other words between the Body and the true East or West points.

FIG. 62

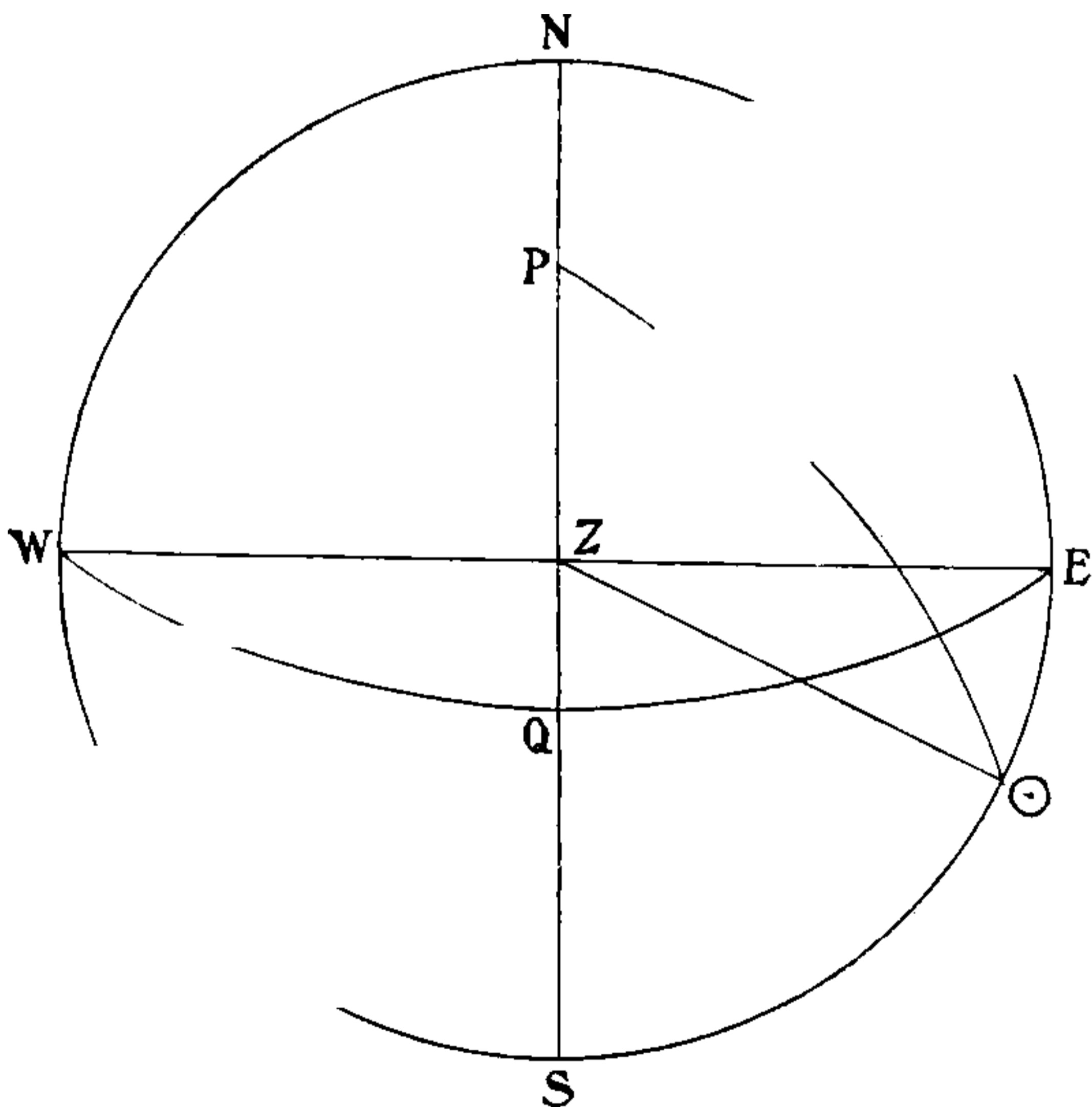

To find the True Bearing of the Sun when rising or setting, use the following formula: $\text{Log. Secant Latitude} + \text{Log. Sine Declination} = \text{Log. Sine of the True Amplitude or True Bearing of the Sun from the East or West point}$. Of course the Amplitude is measured from the East point if the Sun is rising and from the West



THIS PAGE IS LOCKED TO FREE MEMBERS

Purchase full membership to immediately unlock this page

SAVE \$3,999,994

Did you know we sell
paperback books too?

To buy our entire catalog
in paperback would cost
over \$4,000,000

Access it all now for
\$8.99/month

*Fair usage policy applies

Continue

1898, July 16th, at about 5.10 P.M., A. T. S. in Lat. $29^{\circ} 18' S$, and Long. $118^{\circ} E$, the Sun set, Bearing by Compass NW b N, the Variation being $21^{\circ} E$; required the Error of the Compass, and the Deviation for the position of the Ship's Head.

Dec. Var. in $1^h = 25''$
 Time from Noon = 3
 60) 75
1' 15''

A.T.S. July 16th $5^h 10^m 0^s$ Dec. Noon 16th $21^{\circ} 20' 7''$
 Long. in T. . 7 52 0 E Corr. 1' 15''
 A.T.G. July 15th $21^h 18^m 0^s$ Dec. at Sights . $21^{\circ} 21' 22''$

Lat. $29^{\circ} 18' S$ Log. Sec $\cdot 059449$
 Dec. $21^{\circ} 21' N$ Log. Sin $9\cdot 561178$
 $24^{\circ} 41' =$ Tr. Amp. Log. Sin $9\cdot 620627$

Tr. Amp. . W $24^{\circ} 41' N$
 Comp. Bearing W $56^{\circ} 15' N$
 Error of Comp. $31^{\circ} 34' W$
 Var. . . . $21^{\circ} 0' E$
 Dev. . . . $52^{\circ} 34' W$

1898, October 1st, at about 6.13 A.M., A. T. S. in Lat. $47^{\circ} 10' N$, and Long. $170^{\circ} W$, the Sun rose, Bearing by Compass, E b S $\frac{1}{2}$ S, the Variation being $3^{\circ} E$; required the Error of the Compass, and the Deviation for the position of the Ship's Head.

Dec. Var. in $1^h = 58''$
 Time from Noon = 5.5
 290
 290
 60) 319.0
5 19''

A.T.S. Sept. 30th $18^h 13^m 0^s$ Dec. Noon 1st . $3^{\circ} 18' S$
 Long. in Time . 11 20 0 Corr. 5'
 A. T. G. Oct. 1st $5^h 33^m 0^s$ Dec. at Sights $3^{\circ} 23' S$
 = $5\cdot 5^h$

Lat. $47^{\circ} 10'$ Log. Sec $\cdot 167575$
 Dec. $3^{\circ} 23'$ Log. Sin $8\cdot 770970$
 $4^{\circ} 59' =$ Tr. Amp. Log. Sin $8\cdot 938545$

Tr. Amp. . E $4^{\circ} 59' S$
 Comp. Bearing E $16^{\circ} 52' S$
 Comp. Error . $11^{\circ} 53'' W$
 Var. $3^{\circ} 0'' E$
 Dev. $14^{\circ} 53' W$

The problem may be presented to you with the date in civil time A. T. S., as in the preceding examples, in which case Longitude in Time must be applied in order to get a Greenwich date wherewith to correct Declination; or the Time by Chronometer may be given, in which case the Chronometer Time corrected for Error is, of course, the Greenwich Date. Here is the last example given with Chronometer Time :

<table style="border-collapse: collapse; width: 100%;"> <tr> <td style="width: 15%;">Var. Dec. in 1^h</td> <td style="width: 15%;">58·2''</td> <td style="width: 10%;"></td> <td style="width: 10%;"></td> <td style="width: 10%;"></td> <td style="width: 10%;"></td> </tr> <tr> <td>Time from Noon</td> <td>5·38</td> <td></td> <td></td> <td></td> <td></td> </tr> <tr> <td></td> <td style="border-top: 1px solid black;">4656</td> <td></td> <td></td> <td></td> <td></td> </tr> <tr> <td></td> <td>1746</td> <td></td> <td></td> <td></td> <td></td> </tr> <tr> <td></td> <td style="border-top: 1px solid black;">2910</td> <td></td> <td></td> <td></td> <td></td> </tr> <tr> <td>60)</td> <td style="border-top: 1px solid black;">313·116</td> <td></td> <td></td> <td></td> <td></td> </tr> <tr> <td></td> <td style="border-top: 1px solid black;">5' 13·1''</td> <td></td> <td></td> <td></td> <td></td> </tr> </table>	Var. Dec. in 1 ^h	58·2''					Time from Noon	5·38						4656						1746						2910					60)	313·116						5' 13·1''					<table style="border-collapse: collapse; width: 100%;"> <tr> <td style="width: 30%;">Chron. T. 1st</td> <td style="width: 30%;">5^h 21^m 10^s</td> <td style="width: 10%;"></td> <td style="width: 10%;"></td> <td style="width: 10%;"></td> <td style="width: 10%;"></td> </tr> <tr> <td>Error . . .</td> <td>1 22</td> <td></td> <td></td> <td>⊙ Dec. 1st Noon</td> <td>3° 18' 8·1'' S</td> </tr> <tr> <td></td> <td style="border-top: 1px solid black;"></td> <td></td> <td></td> <td>Corr. . . .</td> <td style="border-top: 1px solid black;">5' 13·1''</td> </tr> <tr> <td>M. T. G. 1st</td> <td>5 22 32</td> <td></td> <td></td> <td>⊙ Dec. at Sights</td> <td>3° 23' 21·2'' S</td> </tr> <tr> <td></td> <td>= 5·38 hours.</td> <td></td> <td></td> <td></td> <td></td> </tr> <tr> <td>Lat. 47° 10' 0''</td> <td></td> <td>Log. Sec</td> <td>10·167575</td> <td></td> <td></td> </tr> <tr> <td>Dec. 3° 23' 21''</td> <td></td> <td>Log. Sin</td> <td style="border-bottom: 1px solid black;">8·771717</td> <td></td> <td></td> </tr> <tr> <td></td> <td></td> <td>Tr. Amp. Log. Sin</td> <td>8·939292</td> <td>= 4° 59' 10''</td> <td></td> </tr> <tr> <td></td> <td></td> <td>Tr. Amp. . .</td> <td>E 4° 59' 10''</td> <td>S</td> <td></td> </tr> <tr> <td></td> <td></td> <td>Comp. Bearing</td> <td>E 16° 52' 30''</td> <td>S</td> <td></td> </tr> <tr> <td></td> <td></td> <td>Comp. Error . .</td> <td style="border-bottom: 1px solid black;">11° 53' 20''</td> <td>W</td> <td></td> </tr> <tr> <td></td> <td></td> <td>Var. . . .</td> <td style="border-bottom: 1px solid black;">3° 0' 0''</td> <td>E</td> <td></td> </tr> <tr> <td></td> <td></td> <td>Dev. . . .</td> <td>14° 53' 20''</td> <td>W</td> <td></td> </tr> </table>	Chron. T. 1st	5 ^h 21 ^m 10 ^s					Error . . .	1 22			⊙ Dec. 1st Noon	3° 18' 8·1'' S					Corr. . . .	5' 13·1''	M. T. G. 1st	5 22 32			⊙ Dec. at Sights	3° 23' 21·2'' S		= 5·38 hours.					Lat. 47° 10' 0''		Log. Sec	10·167575			Dec. 3° 23' 21''		Log. Sin	8·771717					Tr. Amp. Log. Sin	8·939292	= 4° 59' 10''				Tr. Amp. . .	E 4° 59' 10''	S				Comp. Bearing	E 16° 52' 30''	S				Comp. Error . .	11° 53' 20''	W				Var. . . .	3° 0' 0''	E				Dev. . . .	14° 53' 20''	W	
Var. Dec. in 1 ^h	58·2''																																																																																																																								
Time from Noon	5·38																																																																																																																								
	4656																																																																																																																								
	1746																																																																																																																								
	2910																																																																																																																								
60)	313·116																																																																																																																								
	5' 13·1''																																																																																																																								
Chron. T. 1st	5 ^h 21 ^m 10 ^s																																																																																																																								
Error . . .	1 22			⊙ Dec. 1st Noon	3° 18' 8·1'' S																																																																																																																				
				Corr. . . .	5' 13·1''																																																																																																																				
M. T. G. 1st	5 22 32			⊙ Dec. at Sights	3° 23' 21·2'' S																																																																																																																				
	= 5·38 hours.																																																																																																																								
Lat. 47° 10' 0''		Log. Sec	10·167575																																																																																																																						
Dec. 3° 23' 21''		Log. Sin	8·771717																																																																																																																						
		Tr. Amp. Log. Sin	8·939292	= 4° 59' 10''																																																																																																																					
		Tr. Amp. . .	E 4° 59' 10''	S																																																																																																																					
		Comp. Bearing	E 16° 52' 30''	S																																																																																																																					
		Comp. Error . .	11° 53' 20''	W																																																																																																																					
		Var. . . .	3° 0' 0''	E																																																																																																																					
		Dev. . . .	14° 53' 20''	W																																																																																																																					

Azimuth

(A Second Mate is required to find the True Azimuth from an Altitude of the Sun, and, given the Variation, to find the Deviation and Compass Error.)

An Azimuth is the angle at the Zenith, or what is the same thing, the angular distance measured along the Horizon between a circle of Altitude passing through a Heavenly Body and the Meridian of the observer. An Azimuth is counted from North or South according to whether the Body is nearest to North or South, and towards East or West according to whether it is rising or setting. The Azimuth of any Heavenly Body can be determined

by calculation based either on its Altitude or upon its Polar Angle. The first method is called an Altitude Azimuth, the second a Time Azimuth.

Let us tackle Altitude Azimuths first, and take the case of the Sun. Find the Sun's True Altitude by observation, take out the corrected Declination, and use the best Latitude available.

The formula is very similar to that used in finding the Sun's Hour Angle. Add together Altitude, Latitude, and Polar Distance; divide the sum by 2 for the half-sum; take the difference between the half-sum and the Polar Distance, and call it the remainder.

Then add together Log. Secant of the Altitude, Log. Secant of the Latitude, Log. Cosine of the half-sum, and Log. Cosine of the remainder, leaving one 10 in the Index; the result divided by 2 is the Log. Sine of half the Azimuth. Take out this angle, multiply it by 2, and you have the Azimuth. In the Longitude Chronometer problem you took the Altitude from the half-sum to get the remainder; in the Altitude Azimuth problem you find the remainder by taking the difference between the half-sum and the Polar Distance. In the former problem it was Secant, Cosecant, Cosine, Sine; in the latter problem it is Secant, Secant, Cosine, Cosine; the difference between the two formulas is not great.

To name the Azimuth. Name it from South if in North Latitude, and from North if in South Latitude, towards the East if the Sun is rising, towards the West if the Sun is falling.

From the Azimuth or True Bearing of the Sun so found, get the Correct Magnetic Bearing by applying the Variation as given on the chart, and the difference between the Correct Magnetic Bearing and the Sun's Bearing by



THIS PAGE IS LOCKED TO FREE MEMBERS

Purchase full membership to immediately unlock this page

DELVE INTO FANTASY, MAGIC, MYTHOLOGY & FOLKLORE

Forgotten Books'
Full Membership gives
access to 797,885 ancient
and modern, fiction and
non-fiction books.

Continue

*Fair usage policy applies

suppose the Compass Bearing is South 10° East, and the True Bearing South 2° West, 12° will be the Error of the Compass.

The only other thing to do is to name the Deviation. If the Correct Magnetic Bearing is to the right of the Compass Bearing, the Deviation is Easterly; if it is to the left, it is Westerly.

Don't forget that in Azimuths and Amplitudes and in all problems involving ascertaining Compass Error, in ascertaining whether True or Correct Magnetic Bearing is to the right or left of the Bearing by Compass, you must consider yourself to be looking from the centre of the Compass out towards the circumference.

To explain the process which has taken place, the diagram employed to illustrate the method of finding Longitude by Sun Chronometer will be useful. Here it is reproduced.

In the Longitude problem we had to find the unknown angle $z P x$, which is the Hour Angle, from the three known sides $P x$, $z x$, $P z$, that is to say from the Polar Distance, the Zenith Distance, and the Colatitude. In the present case of an Altitude Azimuth, the problem is to find the unknown angle $P z x$, which is the Azimuth, from the three same known sides.

In both cases the rigorous method of solution and formula are the same. The difference in the formula recommended for practical working is due to the fact that in finding an Hour Angle the Polar Distance and Colatitude form the two enclosing sides, whereas in finding an Azimuth the Zenith Distance and Colatitude form the two enclosing sides. Should you be required in the examination to illustrate the Alt. Azimuth problem by a figure, draw one precisely similar to the figures illustrating the Sun and Chronometer problem on p. 318, remem-

bering of course that in the Longitude problem you require to find the angle at the Pole (the Hour Angle), whereas in the Alt. Azimuth problem you require to find the Angle at the Zenith (the Azimuth).

The True Bearing or Azimuth of a fixed Star or Planet or of the Moon is found in precisely the same way as that of the Sun, and is equally useful for ascertaining

FIG. 63

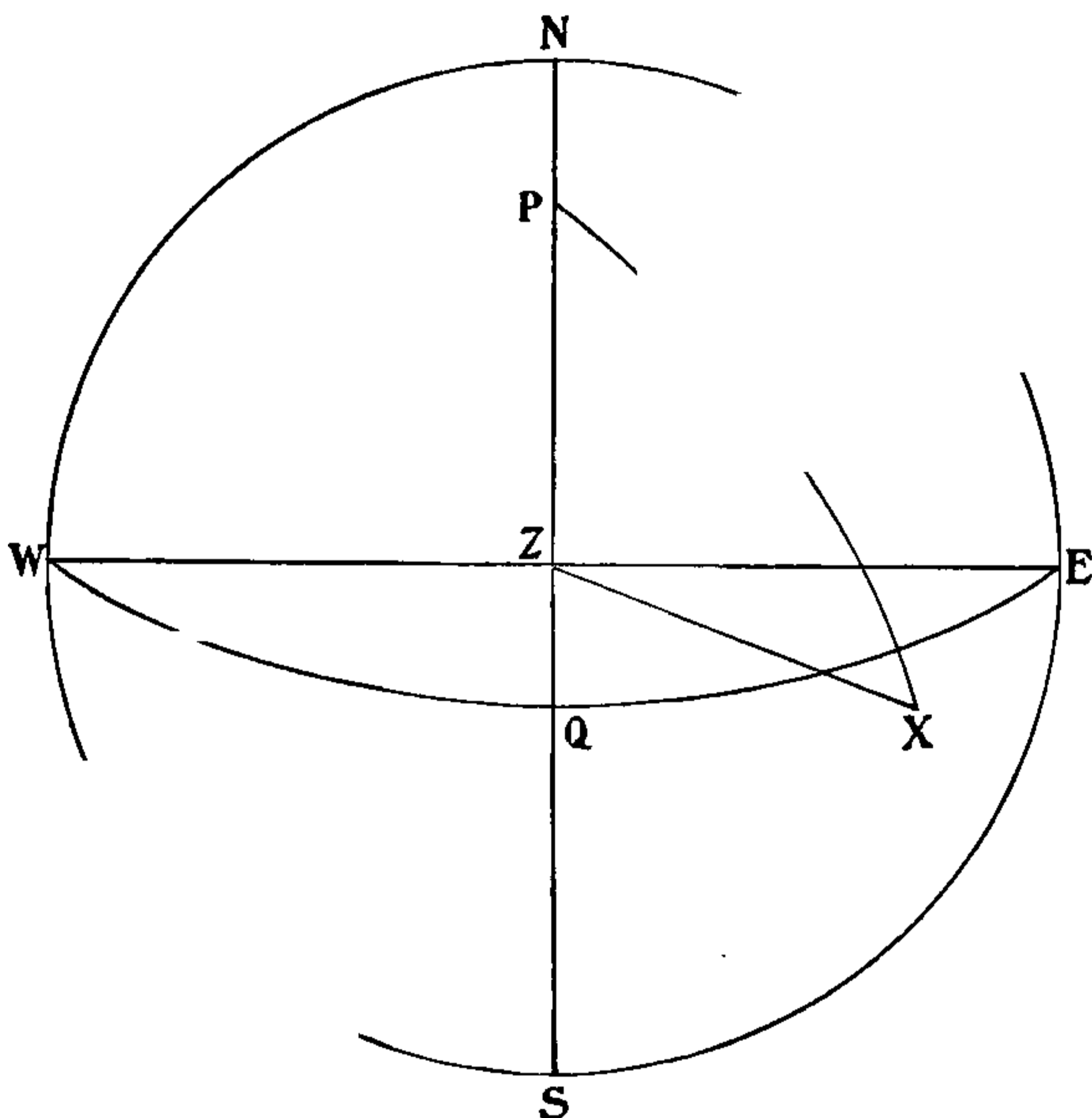

Compass Error and Deviation. They will be discussed later on.

So much for working out an Altitude Azimuth of the Sun. Here are some examples :

1898, January 15th, at about 9.10 A.M., in Lat. $40^{\circ} 20' N$, and Long. $121^{\circ} 24' E$, Obs. Alt. $\odot 16^{\circ} 46' 0''$, I. E. $-1' 40''$, Height of the Eye 16 ft., when the Sun bore by Compass $S 40^{\circ} E$, Variation $22^{\circ} E$; required the Error

of the Compass, and the Deviation for the position of the Ship's Head.

Dec. Var. in 1 ^h = 27''	Ship Time 14th . 21 ^h 10 ^m 0 ^s	⊙ Dec. 21° 15' 1'' S
Time from Noon = 13·1	Long. in Time . 8 5 36	Corr. 5' 54''
27	Greenwich Date 14th 13 ^h 4 ^m 24 ^s	Corr. Dec. 21° 9' 7'' S
81		
27		P. D. 111° 9' 7''
60) 353·7	Obs. Alt. 16° 46' 0''	
5' 54''	I. E. - 1' 40''	
	16° 44' 20''	
	Dip 3' 56''	
	16° 40' 24''	
S.-D. . .	16' 17''	
	16° 56' 41''	
Ref. . .	3' 5''	
	16° 53' 36''	
Parallax .	8''	
Tr. Alt. .	16° 53' 44''	Sec 0·019162
Lat. . .	40° 20' 0''	Sec 0·117879
P. D. .	111° 9' 7''	
Sum . 2)	168° 22' 51''	
$\frac{1}{2}$ Sum .	84° 11' 26''	Cos 9·005268
Remainder .	26° 57' 41''	Cos 9·950030
		2) 19·092339
	20° 35' 30'' = $\frac{1}{2}$ Azimuth Sin	9·546169
$\frac{1}{2}$ Azimuth .	20° 35' 30''	
	2	
True Azimuth .	S 41° 11' 0'' E	
Comp. Azimuth	S 40° 0' 0'' E	
Comp. Error .	1° 11' 0'' W	
Variation .	22° 0' 0'' E	
Deviation .	23° 11' 0'' W	

1898, May. 6th, in Lat. 55° 10' N, Long. 39° 15' W, at about 5.20 P.M., Obs. Alt. ⊙ 19° 13' 0'', I. E. - 1' 50'' Height of the Eye 20 ft., the Sun bore by Compass West,



THIS PAGE IS LOCKED TO FREE MEMBERS

Purchase full membership to immediately unlock this page

SAVE \$3,999,994

Did you know we sell
paperback books too?

To buy our entire catalog
in paperback would cost
over \$4,000,000

Access it all now for
\$8.99/month

*Fair usage policy applies

Continue

the Var. 25° W ; required the Error of the Compass, and the Deviation for the position of the Ship's Head.

Dec. Var. in $1^h = 58.3''$ Time from Noon = 4 <hr style="width: 50%; margin-left: 0;"/> 23.32	Ship Time 19th . $2^h 10^m$ Long. in Time . $2 34 E$ Green. Date 18th $23^h 36^m$	Dec. $1^{\circ} 22' 19.3''$ Cor. $+ 23.3'' N$ Cor. Dec. = $1^{\circ} 22' 43'' N$ P. D. $91^{\circ} 22' 43''$
	Obs. Alt. . $40^{\circ} 1' 0''$ I. E. . . $+ 2' 15''$ <hr style="width: 50%; margin-left: 0;"/> $40^{\circ} 3' 15''$ Dip . . . $5' 11''$ <hr style="width: 50%; margin-left: 0;"/> $39^{\circ} 58' 4''$ S. D. . . $15' 57''$ <hr style="width: 50%; margin-left: 0;"/> App. Alt. . $40^{\circ} 14' 1''$ Refs. . . $- 1' 8''$ <hr style="width: 50%; margin-left: 0;"/> $40^{\circ} 12' 53''$ Par. . . . 9 <hr style="width: 50%; margin-left: 0;"/> Tr. Alt. . $40^{\circ} 13' 0''$ Lat. . . . $38^{\circ} 25' 0''$ P. D. . . . $91^{\circ} 22' 43''$ <hr style="width: 50%; margin-left: 0;"/> Sum . $2) 170^{\circ} 0' 43''$ <hr style="width: 50%; margin-left: 0;"/> $\frac{1}{2}$ Sum . $85^{\circ} 0' 21''$ Remainder $6^{\circ} 22' 21''$	Sec $.117129$ Sec $.105954$ Cos 8.939791 Cos 9.997308 <hr style="width: 50%; margin-left: 0;"/> $2) 19.160182$ <hr style="width: 50%; margin-left: 0;"/> $22^{\circ} 21' = \frac{1}{2}$ Azimuth Sin 9.580091
	$\frac{1}{2}$ Azimuth . $N 22^{\circ} 21' W$ <hr style="width: 50%; margin-left: 0;"/> Tr. Azimuth . $N 44^{\circ} 42' W$ Comp. Bearing North <hr style="width: 50%; margin-left: 0;"/> Error . . . $44^{\circ} 42' W$ Var. . . . $25^{\circ} 0' W$ <hr style="width: 50%; margin-left: 0;"/> Dev. . . . $19^{\circ} 42' W$	

At sea you would probably work an Altitude Azimuth for ascertaining Compass Error with the Sun's Altitude observed at your A.M. or P.M. sights for Longitude, and the problem is likely to be presented in that form in the Board of Trade Examination.

So much for Altitude Azimuths.

Time Azimuth

(A Second Mate is required to be able to take out the True Azimuth of the Sun from the Time Azimuth Tables.)

A Time Azimuth consists of taking the Compass Bearing of a Heavenly Body, and noting the Apparent Time at Ship. You then find the True Bearing of the body at that time, and from the True Bearing and Compass Bearing you find the Deviation as in an Altitude Azimuth.

The Azimuth of any body at any time can be found by calculation. It can also be taken out from various tables compiled for the purpose, and as the method by calculation is long and the method by tables is short, and sufficiently accurate, the latter is always adopted both in practical sea-work and for the Board of Trade Examination. In case any reader is curious on the subject, the calculation formula is mentioned later on. Let us use the tables to start with, and begin with the Sun.

To find the Deviation of your Compass by a Time Azimuth of the Sun.—Note the time shown on your Chronometer when you take the Sun's Bearing by Compass, correct it for the Chronometer Error, turn the Greenwich Mean Time so found into Apparent Time at Greenwich by applying the Equation of Time, and convert Apparent Time at Greenwich into Apparent Time at Ship by applying the Longitude in Time. Or get your Apparent Time at Ship by finding the Sun's Hour Angle, which is Apparent Time at Ship, by the method already described in the Longitude by Chronometer problem.

To find the Sun's Azimuth.—If your Latitude lies within 30° and 60° North or within 30° and 60° South, use Burdwood's Tables. Find the Sun's Declination for the Greenwich date corresponding to Apparent Time at Ship.

If Latitude and Declination are both North or both South, use the pages of the tables marked 'Declination—same name as—Latitude.' If your Latitude and Declination are one North and the other South, use the pages marked 'Declination—contrary name to—Latitude.' Find the page containing your Latitude to the nearest degree. Enter the table with your Declination to the nearest degree at the top, and your Apparent Time at Ship A.M. or P.M., to the nearest minute, at the side, and take out the Sun's Azimuth in degrees and minutes. At the bottom of the page you will find directions how to name the Azimuth, whether from north to east or north to west, or south to east or south to west. If the Azimuth is over 90° take it from 180° , changing the sign from north to south or from south to north as the case may be, and you have the Sun's True Azimuth or Bearing. Compare this with the Bearing by Compass and you have the Error of the Compass; to this apply the Variation, and you have the Deviation of the Compass.

If your position lies between Latitude 30° North and Latitude 30° South, use Davis' Tables, which are constructed on the same plan as Burdwood.

In both Burdwood's and Davis' Tables, Latitude and Declination are given in degrees only, and A.M. and P.M. time is given for every hour and every four minutes. If your Latitude lies between two Latitudes in the tables, or if your Declination lies between two Declinations given, or your time does not exactly correspond with the hour and minute in the tables, you must roughly average the Azimuth. For instance, your Latitude may be $50^\circ 30'$, in which case you should average the Azimuth for Latitudes 50° and 51° . Or your Declination may be $18^\circ 40'$, in which case you should average the Azimuth for Declination 18° and 19° . Or your time may be 8 hours



THIS PAGE IS LOCKED TO FREE MEMBERS

Purchase full membership to immediately unlock this page

DELVE INTO FANTASY, MAGIC, MYTHOLOGY & FOLKLORE

Forgotten Books'
Full Membership gives
access to 797,885 ancient
and modern, fiction and
non-fiction books.

Continue

*Fair usage policy applies

2. June 18th, 1898, in Lat. $31^{\circ} 20' S$, Long. $162^{\circ} 10' E$, Time by Chronometer 17th 15 h. 31 m. 50 s., whose error on M. T. G. was 2 m. 18 s. slow, the Sun bore by Compass NW b N, Var. $21^{\circ} E$; required the Error of the Compass, and the Dev. for the position of the Ship's Head by Time Azimuth.

Dec. Var. in $1^h = 3''$ Time from Noon = 8.4 <hr style="width: 50%; margin: 0 auto;"/> 25.2	Dec. on 18th $23^{\circ} 25' 25''$ <div style="text-align: right; margin-right: 10px;">25</div> <hr style="width: 50%; margin: 0 auto;"/> Corr. Dec. . $23^{\circ} 25' N$	Chronom. 17th $15^h 31^m 50^s$ Error . . . $+ 2 18$ <hr style="width: 50%; margin: 0 auto;"/> M. T. G. 17th . $15 34 8$ E. T. $- 46$ <hr style="width: 50%; margin: 0 auto;"/> A. T. G. 17th . $15 33 22$ Long in T. . . $10 48 40$ <hr style="width: 50%; margin: 0 auto;"/> A. T. S. 18th . $2 22 2$
E. T. Var. in $1^h = .55^{\circ}$ 8.4 <hr style="width: 50%; margin: 0 auto;"/> 220 440 <hr style="width: 50%; margin: 0 auto;"/> 4.620	E. T. 18th. $0^m 51.3^s$ <div style="text-align: right; margin-right: 10px;">4.6</div> <hr style="width: 50%; margin: 0 auto;"/> Corr. E. T. $0^m 46.7^s -$ on M. T.	

By Burdwood

Lat. $31^{\circ} 20' S$, Dec. $23^{\circ} 25' N$, and A. T. S. $2^h 22^m$ P.M. gives the True Azimuth as $S 143^{\circ} 40' W = N 36^{\circ} 20' W$

True Azimuth .	N	$36^{\circ} 20'$	W
Comp. Azimuth	N	$33^{\circ} 45'$	W
		<hr style="width: 50%; margin: 0 auto;"/>	
Comp. Error .		$2^{\circ} 35'$	W
Var.		$21^{\circ} 0'$	E
		<hr style="width: 50%; margin: 0 auto;"/>	
Dev.		$23^{\circ} 35'$	W

3. October 21st, 1898, in Lat. $15^{\circ} 48' N$, Long. $84^{\circ} 25' W$, when a Chronometer showed on the 21st 2 h. 55 m. 10 s., whose error on M. T. G. was fast 1 m. 10 s., the Sun bore by Compass S $41^{\circ} E$, Var. $19^{\circ} 30' W$; required the Error of the Compass and the Dev. for the position of the Ship's Head by Time Azimuth.

Dec. Var. in $1^h = 53.4''$ Time from Noon = 3 <hr style="width: 50%; margin: 0 auto;"/> $60)160.2$ <hr style="width: 50%; margin: 0 auto;"/> $2' 40''$	Dec. on 21st $10^{\circ} 49'$ <div style="text-align: right; margin-right: 10px;">$3'$</div> <hr style="width: 50%; margin: 0 auto;"/> Corr. Dec. . $10^{\circ} 52' S$	Chronom. 21st $2^h 55^m 10^s$ Error . . . $1 10$ <hr style="width: 50%; margin: 0 auto;"/> M. T. G. 21st . $2 54 0$ E. T. $+ 15 20$ <hr style="width: 50%; margin: 0 auto;"/> A. T. G. 21st . $3 9 20$ Long. in T. . . $5 37 40$ <hr style="width: 50%; margin: 0 auto;"/> A. T. S. 20th . $21 31 40$
E. T. Var. in $1^h = .4^{\circ}$ 3 <hr style="width: 50%; margin: 0 auto;"/> 1.2	E. of T. 21st $15^m 19^s$ <div style="text-align: right; margin-right: 10px;">1</div> <hr style="width: 50%; margin: 0 auto;"/> Corr. E. T. $15^m 20^s +$ to M. T.	

By Davis

Lat. $15^{\circ} 48' N$, Dec. $10^{\circ} 52' S$, and $9^h 32^m$ A.M. gives the True Azimuth as $N 123^{\circ} 20' E = S 56^{\circ} 40' E$.

True Azimuth .	S	56° 40' E
Comp. Azimuth	S	41° 0' E
Comp. Error .		15° 40' W
Var. . . .		19° 30' W
Dev. . . .		3° 50' E

Time Azimuths of Stars, Planets and the Moon may sometimes be taken out from Burdwood's and Davis' Tables. But as in these tables Declination is not given above 23° , other tables must be used when the Declination of the Heavenly Body observed exceeds 23° .

In finding the Azimuth of a Heavenly Body other than the Sun by Burdwood's or Davis' Tables, you must get rid of the idea of A.M. and P.M. time. Remember that in the case of the Sun P.M. time is merely the Hour Angle west and A.M. the Hour Angle east.

In the case of a Star.—Take out the Star's Declination from the Nautical Almanac and find its Hour Angle west in the usual way. If the Star's Westerly Hour Angle does not exceed twelve hours, enter the table with your Latitude, and the Star's Declination, and its Hour Angle as P.M. time, and take out the Azimuth. If the Star's Westerly Hour Angle exceeds 12 hours, deduct 12 hours from it, and look for the balance as A.M. time in the table. Burdwood's and Davis' Tables would have been simpler if astronomical time had been used instead of civil time, and time had run from 0 to 24 hours. As it is, A.M. time + 12 hours is the Sun's Westerly Hour Angle, and consequently a star's Westerly Hour Angle — 12 hours is the same thing as A.M. time as far as Burdwood's and Davis' Tables are concerned.

If the star's or other Heavenly Body's Declination exceeds 23° , use Johnson's or Towson's Tables. Johnson's Tables are contained in a small book entitled 'The Bearings

of the Principal Bright Stars,' which will be found very useful for practical work. A good explanation of the method of using the tables is contained in the book, and therefore no further explanation is necessary here. But as Johnson's Tables are not, I believe, permitted in the Board of Trade Examination, a learner must familiarise himself with Towson's Tables, which are permitted. The advantage of Towson's Tables is that the Azimuth of all Navigational Heavenly Bodies, Sun included, can be found by them. Their disadvantage lies in the fact that they are somewhat complicated. A very full explanation of their use is given in 'Towson's Tables' which cannot, I think, be condensed or simplified. As the use of the tables *minus* the explanation of them is alone permitted in the Examination Room, the aspirant for a Master's Certificate must commit to memory and should thoroughly understand the various ways in which the tables are used for finding the Azimuth of the Sun, Stars, Planets, and the Moon.

(A First Mate is required to find the True Azimuth of a Star by the Time Azimuth Tables.)

I promised the formula whereby the Time Azimuth of any Heavenly Body may be calculated. Here it is. Use the same figure that has been given to illustrate how to find an Hour Angle, or an Altitude Azimuth. To avoid the trouble of turning back it is reproduced on the next page.

In the case of an Hour Angle, the problem was to find the unknown angle $Z P X$, having the three sides $P Z$, $P X$, $Z X$, given; in the case under consideration the problem is to find the unknown angle $P Z X$ —which is the Azimuth, the angle $Z P X$ and the two sides including that angle, namely $P Z$, $P X$, being known.

To avoid any possible ambiguity the best plan is to find the opposite side $Z X$ first. This is done



THIS PAGE IS LOCKED TO FREE MEMBERS

Purchase full membership to immediately unlock this page

SAVE \$3,999,994

Did you know we sell
paperback books too?

To buy our entire catalog
in paperback would cost
over \$4,000,000

Access it all now for
\$8.99/month

*Fair usage policy applies

Continue

require to find the angle $P Z X$, which is the **True Azimuth**. Proceed thus :

	°	'	"			
$P Z$	—	—	—	Log. Cosec	—	—
$Z X$	—	—	—	Log. Cosec	—	—
$P X$	—	—	—			
2)	—	—	—			
$\frac{1}{2}$ Sum	—	—	—	Log. Sin .	—	—
$\frac{1}{2}$ Sum $\sim P X$	—	—	—	Log. Sin .	—	—
				2)	—	—
					—	—
					= Log. Cos. $\frac{1}{2} P Z X$	
	°	'	"			
$\frac{1}{2} P Z X =$	—	—	—			
					= $P Z X$ the True Azimuth	

The first of the above formulas for finding the side opposite to a known angle, of which the including sides

FIG. 64

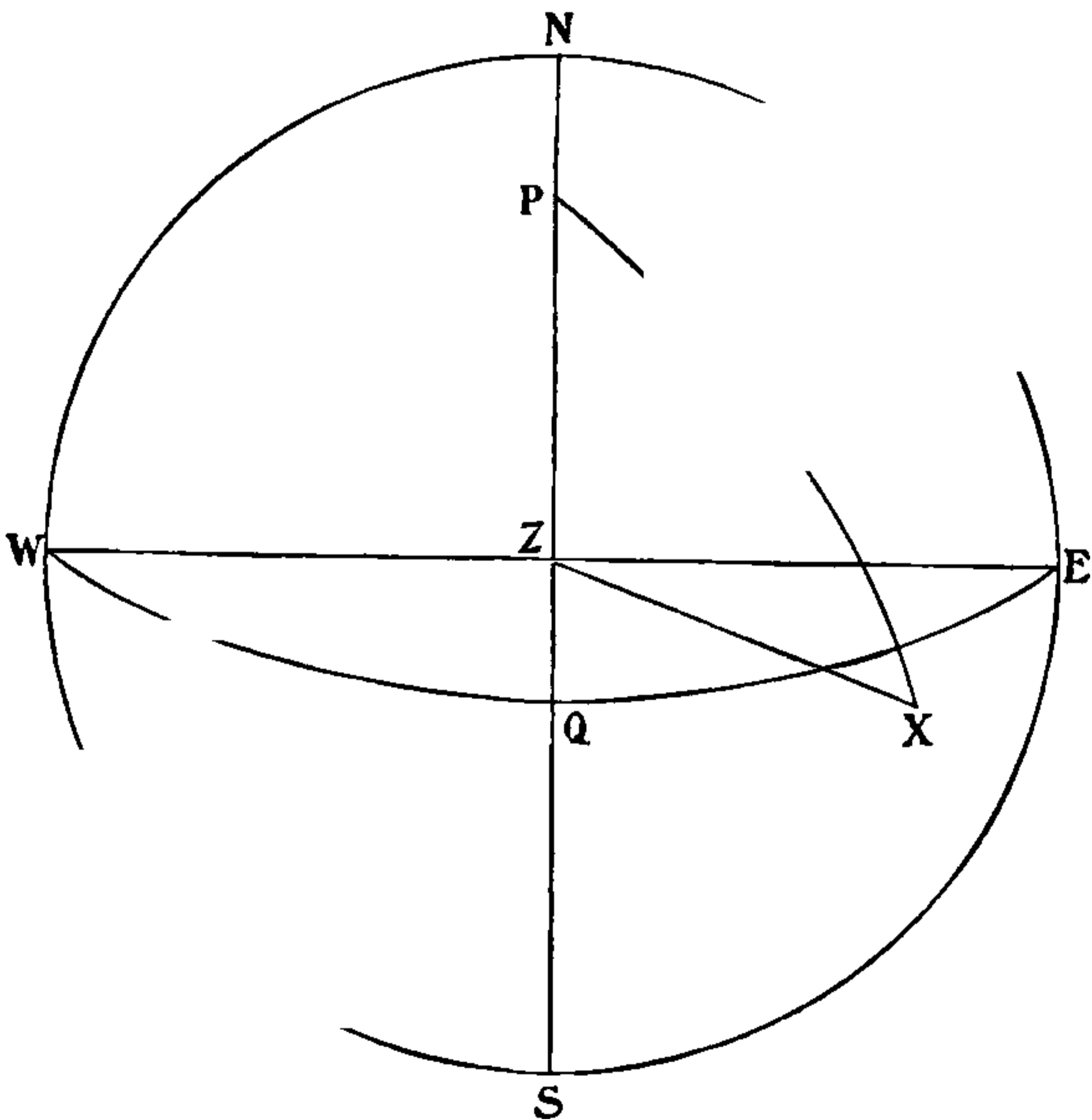

are also known, is very useful, and should be remembered for future use, as it is employed in Double Altitudes, Lunars, and Great Circle Sailing, which problems will be dealt with later on in treating of **Extra Master's** work.

CHAPTER XV

REDUCTION TO THE MERIDIAN

IT may frequently happen that though the Sun is obscured at Noon, and consequently a Meridian Altitude is unattainable, it is visible shortly before or after Noon. In such a case Latitude can be obtained by an Ex-Meridian, that is to say, by an Altitude taken before or after the Sun is on the Meridian. This problem is usually called ‘a Reduction to the Meridian.’ The term ‘reduction,’ is classically correct, but remember that it is not used in the customary sense of implying making the Altitude *less*. On the contrary, the reduction always makes the Altitude *greater*, for obviously if the Altitude is taken before Noon it will be less than the Altitude to which the Sun will attain at Noon, and if it be taken after Noon it is less than the altitude to which the Sun had attained at Noon.

The problem consists simply in finding the exact interval of time elapsing between Noon and the moment the Altitude was obtained—in other words, in finding the ‘Time from Noon’ and in adding to the angle of the true Altitude derived from the observation an angle depending on the time from Noon. The angle to be added is calculated; the diagram which follows presently will explain the theory, but no one need bother about the theory unless he is theoretically inclined.

The method of finding the reduction is as follows:

(1) *Find the ‘Time from Noon.’*—‘Time from Noon’ is of course the Sun’s Polar Angle. To obtain this, note the

time of taking the Altitude by Chronometer and correct it for error. This gives the Greenwich date (M. T. G.) of the sight; to this apply your Dead Reckoning Longitude in time, thus obtaining Mean Time at Ship; take out the Equation of Time from the Nautical Almanac for the Greenwich date, and apply it, with the sign given in the Nautical Almanac, and you have Apparent Time at Ship, or 'Time from Noon.'

(2) *Find the Sun's Declination.*—Take the Declination out of the Nautical Almanac and correct it for the Greenwich date of your sight.

(3) *Find the Approximate Meridian Zenith Distance.*—Use your Dead Reckoning Latitude, and if Latitude and Declination are of the *same* name take their *difference*, if of *different* names take their *Sum*; the result is the Meridian Zenith Distance.

Then use the following formula :

Log. H. A. (Time from Noon) + Log. Cosine of the Latitude + Log. Cosine of the Declination + Log. Cosecant of the Meridian Zenith Distance = Log. Sine of half the Reduction.

The sum presents itself thus :

Time from Noon	Log.	.	—	—	—
Lat.	Log. Cos	.	—	—	—
Dec.	Log. Cos	.	—	—	—
Mer. Z. D.	Log. Cosec		—	—	—
	Log. Sin. $\frac{1}{2}$ Reduction =		—	—	—
				2	
			—	—	— = Reduction

There is not much difficulty about this, and you will easily remember Log. of Time from Noon and then Cosine, Cosine, Cosecant, Sine.

Having found the Reduction, proceed to find the Latitude as in working a Meridian Altitude of the Sun. Find True Altitude from Observed Altitude, *add* the Reduction,



THIS PAGE IS LOCKED TO FREE MEMBERS

Purchase full membership to immediately unlock this page

DELVE INTO FANTASY, MAGIC, MYTHOLOGY & FOLKLORE

Forgotten Books'
Full Membership gives
access to 797,885 ancient
and modern, fiction and
non-fiction books.

Continue

*Fair usage policy applies

Example I.—March 19th, 1898, A.M. at Ship, Lat. D.R. $38^{\circ} 38' N$, Long. $47^{\circ} 28' W$, a Chronometer showed on the 19th 2 h. 57 m. 30 s., Chronometer slow 1 m. 19 s. on M.T.G., Obs. Alt. Sun's L.L. $50^{\circ} 50' 50''$, Bearing South, Height of Eye 14 feet. Required the Latitude by Ex-Meridian.

Dec. Var. in 1 ^h 59.28"	Dec. on 19th $0^{\circ} 25' 47.4''$	Chron. 19th	2 ^h 57 ^m 30 ^s
T. from Noon 3	<u>2' 57.8''</u>	Error	+ 1 19
60)177.84	Corr. Dec. $0^{\circ} 22' 49.6'' S$	M. T. G. 19th	2 58 49
Corr. 2' 57.8''	E. T. 19th $7^m 49.4^s$	Long. in Time	3 9 52
E. T. Var. in 1 ^h .743 ^s	<u>2.2</u>	M. T. S. 18th	23 48 57
3	Corr. E. of T. $- 7 47.2$	E. T.	- 7 47
Corr. 2.229		A. T. S. 18th	23 41 10
			<u>24 0 0</u>
		T. from Noon	0 18 50

To find the Reduction

T. from Noon	1 ^h 18 ^m 50 ^s	Log.	7.227190
Lat. D. R.	$38^{\circ} 38' 0'' N$	Log. Cos	9.892739
Dec.	$0^{\circ} 22' 50'' S$	Log. Cos	9.999991
M. Z. D.	$39^{\circ} 0' 50''$	Log. Cosec	2.00998
	$0^{\circ} 7' 12'' = \frac{1}{2}$ Red. Log. Sin		7.320918
	$\frac{1}{2}$ Red. = $0^{\circ} 7' 12''$		
	<u>2</u>		
	Red. = $0^{\circ} 14' 24''$		

Obs. Alt. \odot	$50^{\circ} 50' 50''$
Dip	<u>3' 41''</u>
S.-D.	$50^{\circ} 47' 9''$
	<u>16' 5''</u>
	$51^{\circ} 3' 14''$
Ref	<u>47''</u>
	$51^{\circ} 2' 27''$
Par.	<u>5''</u>
Tr. Alt.	$51^{\circ} 2' 32''$
1st Redn.	<u>$0^{\circ} 14' 24''$</u>
	$51^{\circ} 16' 56''$
Red. Tr. Alt.	$51^{\circ} 16' 56'' S$
	<u>$90^{\circ} 0' 0''$</u>
Z. D.	$38^{\circ} 43' 4'' N$
Dec.	<u>$22' 50'' S$</u>
Latitude	$38^{\circ} 20' 14'' N$

Example II.—June 10th, 1898, P.M. at Ship, Lat. D.R. $50^{\circ} 40' N$, Long. $156^{\circ} 40' W$, when a watch showed 0 h. 51 m. 54 s. whose error on A.T.S. had been found to be 1 m. 18 s. fast, since which the ship's run was $N 65^{\circ} W$

true 24 miles, Obs. Alt. Sun's L. L. $60^{\circ} 53' 30''$, Bearing South, I. E. $- 1' 10''$, Height of Eye 21 feet. Required the Latitude by Ex-Meridian. Let us work this to a second Reduction.

<p><i>Run</i> N 65° W 24 miles = Dep. 21.8, which in Lat. 50° = Diff. Long. $34'$ = 2^m 16^s W</p> <p>Dec. Var. in $1' 10.6''$ <u>11.3</u> 318 1166 60) 119.78 Corr. $1' 59.8''$</p>	<p>Watch . . . $0^h 51^m 54^s$ Error . . . $- 1 18$ <u>0 50 36</u> Diff. Long. . . $- 2 16$ A. T. S. 10th . . . $0 48 20$ Long. in Time $10 26 40$ W <u>A. T. G. 10th . . . $11 15 0$</u></p>	<p>Dec. $23^{\circ} 2' 35.5''$ Corr. <u>$1' 59.8''$</u> $23^{\circ} 4' 35.3''$ N</p>
---	---	---

To find 1st Reduction

T. from Noon	$0^h 48^m 20^s$	Log.	8.044458
Lat.	$50^{\circ} 40' 0''$ N	Cos	9.801973
Dec.	$23^{\circ} 4' 35''$ N	Cos	9.963780
M. Z. D.	$27^{\circ} 35' 25''$	Cosec	$.334282$
	$0^{\circ} 47' 57'' = \frac{1}{2}$ Red. Sin		8.144493
	$\frac{1}{2}$ Red. = $0^{\circ} 47' 57''$		
	2		
	1st Red. = $1^{\circ} 35' 54''$		

To find 2nd Reduction

1st Red. $1^{\circ} 35' 54''$	Sin . . .	8.445483
		2
	2 Sin . . .	16.890966
$62^{\circ} 39' 2''$	Tan . . .	10.2863
	Const. Log.	9.6990
$0^{\circ} 2' 35'' = 2^{\text{nd}}$ Red. Sin		6.8762

Obs. Alt.	$60^{\circ} 53' 30''$ S
I. E.	$- 1' 10''$
	<u>$60^{\circ} 52' 20''$</u>
Dip	$4' 30''$
	<u>$60^{\circ} 47' 50''$</u>
S.-D.	$15' 46''$
	<u>$61^{\circ} 3' 36''$</u>
Ref.	$32''$
	<u>$61^{\circ} 3' 4''$</u>
Par.	$4''$
Tr. Alt.	$61^{\circ} 3' 8''$
1st Redn.	$1^{\circ} 35' 54''$
	<u>$62^{\circ} 39' 2''$</u>
2nd Redn.	$2' 35''$
	<u>$62^{\circ} 36' 27''$ S</u>
Red. T. A.	$90^{\circ} 0' 0''$
Z. D.	$27^{\circ} 23' 33''$ N
Dec.	$23^{\circ} 4' 35''$ N
Latitude	<u>$50^{\circ} 28' 8''$ N</u>

In No. 1 Problem Chronometer Time is used, and the Sun's Polar Angle or Time from Noon derived from it. In No. 2 Problem the time is taken by a watch whose error on Apparent Time at Ship was determined probably when the morning sights were taken. But if you change your Longitude you change your time; for instance, if you set your watch to London time and then go to New York without altering your watch, you would find it to be nearly 5 hours fast of New York time. But if you went to St. Petersburg instead it would be 2 hours slow, and the reason for this is that for every 15° of Longitude you go to the Westward you lose an hour in your time, and for every 15° of Longitude you go to the Eastward you gain an hour, and so on. Now in Problem No. 2 your ship has sailed N 65° W 24 miles, and by doing so has altered her Longitude $34'$ to the Westward, and $34'$ of Longitude equals 2 m. 16 s. of Time that you have lost. Hence these 2 m. 16 s. must be subtracted from your time by watch. If your run had been to the Eastward the Diff. Long. in Time would have had to be added.

An Ex-Meridian is an extremely useful problem, and that it is a simple one must be admitted; moreover the second Reduction need not be found unless the Time from Noon is very large or the Sun passes the Meridian very near the Zenith. A good rough rule is that the number of minutes of time from Noon should never exceed the number of degrees in the Zenith Distance. For instance, if the Meridian Altitude of the Sun is 50° , the Zenith Distance is of course 40° , and the time from Noon should not exceed 40 minutes.

There is, however, a rigorous method of working these problems by right-angled spherical trigonometry



THIS PAGE IS LOCKED TO FREE MEMBERS

Purchase full membership to immediately unlock this page

SAVE \$3,999,994

Did you know we sell
paperback books too?

To buy our entire catalog
in paperback would cost
over \$4,000,000

Access it all now for
\$8.99/month

*Fair usage policy applies

Continue

Observed Altitude requires no correction for Semi-Diameter or Parallax. Here is an example :

1898, Jan. 21st, the Obs. Mer. Alt. of the Star Sirius, South of Observer, was $23^{\circ} 18' 20''$, I. E. + $1' 10''$, Height of Eye 17 feet. Required the Latitude.

Obs. Mer. Alt.	$23^{\circ} 18' 20''$
I. E.	+ $1' 10''$
	$23^{\circ} 19' 30''$
Dip.	$4' 4''$
	$23^{\circ} 15' 26''$
Ap. Alt.	$23^{\circ} 15' 26''$
Ref.	$2' 14''$
	$23^{\circ} 13' 12''$ S
Tr. Alt.	$23^{\circ} 13' 12''$ S
	$90^{\circ} 0' 0''$
Z. D.	$66^{\circ} 46' 48''$ N
Dec.	$16^{\circ} 34' 37''$ S
	$50^{\circ} 12' 11''$ N
Lat.	$50^{\circ} 12' 11''$ N

Having now gone through nearly all the ordinary problems, it may be well, before passing to other subjects, to enumerate the formulas recommended in working a Meridian Altitude of the Sun, and in those problems in which the Trigonometrical ratios are used. Though considerable time and space has been consumed in describing and explaining the formulas, it will be seen that they are few in number and very simple. Here they are, and you may as well see that you have them firmly fixed in your memory before going up for examination.

Parallel sailing. To find the Diff. Long.—To Secant Lat. add Log. Dep. ; the result is Diff. Long.

Mercator's sailing. To find Course and Distance.—Find the Diff. Lat., the Mer. Diff. Lat., and the Diff. Long. From Log. Diff. Long. (with 10 added to Index) take Log. Mer. Diff. Lat. ; the result is Tangent of the Course. To Secant of Course add Log. Diff. Lat. ; the result is the Distance.

Lat. by Meridian Alt. of the Sun.—Find True Alt. from Obs. Alt. and find Corr. Dec.

$90^\circ - \text{True Alt.} = \text{Z. D.}$, N if Sun is S of you, S if Sun is N of you. The sum of Z. D. and Dec. is the Lat. if Z. D. and Dec. are of the same name. The difference between Z. D. and Dec. is the Lat. if Z. D. and Dec. are of different names, and Lat. is of the name of the greater of the two.

Amplitude. To find the True Amplitude of the Sun, and thence the error of the Compass and the Deviation.—Find A. T. G. and Sun's Corr. Dec. To Sec. Lat. add Sin. Dec.; the result is Sin. of True Amplitude.

Name the Amplitude, E if A.M., W if P.M., and towards N if Dec. is N, or towards S if Dec. is S.

The error of the Compass is the difference between the True Amplitude and the Sun's Bearing by Compass. The Dev. of the Compass is the error with Var. eliminated.

Longitude by Sun and Chronometer.—Find M. T. G. (Chron. corrected), Corr. Dec. and Corr. E. T.

To find the Sun's Hour Angle. $\text{Alt.} + \text{Lat.} + \text{P. D.} = \text{Sum}$. $\text{Sum} \div 2 = \frac{1}{2} \text{Sum}$. $\frac{1}{2} \text{Sum} - \text{Alt.} = \text{Remainder}$.

Add together Sec Lat., Cosec P. D., $\text{Cos } \frac{1}{2} \text{Sum}$, Sin Remainder; the result is the Log. of the H. A. and the Hour Angle is A. T. S.

A. T. S. + or - E. T. is M. T. S. Difference between M. T. S. and M. T. G. is Longitude.

Altitude Azimuth of the Sun. To find the Sun's True Azimuth and thence the error of and Deviation of the Compass.—Find Corr. M. T. G. Dec. and E. T.

$\text{Alt.} + \text{Lat.} + \text{P. D.} = \text{Sum}$. $\text{Sum} \div 2 = \frac{1}{2} \text{Sum}$.

Difference between $\frac{1}{2} \text{Sum}$ and P. D. = Remainder.

Add together Sec Alt., Sec Lat., $\text{Cos } \frac{1}{2} \text{Sum}$, Cos

Remainder; the result is Sin of half the True Azimuth. Multiply by 2 and you have the True Azimuth.

Name the Azimuth from N in Lat. S, from S in Lat. N, towards E if A.M., towards W if P.M.

The error of the Compass is the difference between the True Azimuth and the Sun's Bearing by Compass. The Dev. is the error with Var. eliminated.

Reduction to the Meridian.—Find Corr. Dec. and E. T: Find A. T. S., that is time from Noon of your observation. Find estimated Mer. Z. D.

Add together Log. Time from Noon, Cos Lat. (by D. R.), Cos Dec., Cosec Mer. Z. D.; the Result is Sin of half the Reduction. Multiply by 2 and you have the Reduction. Add Reduction to True Alt. as observed, and you have the True Mer. Alt. To find Lat. proceed as in a Mer. Alt. of the Sun:

END OF THE FIRST VOLUME