



XIII. On unipolar induction: Another experiment and its significance and evidence for the existence of the æther

E.H. Kennard Ph.D.

To cite this article: E.H. Kennard Ph.D. (1917) XIII. On unipolar induction: Another experiment and its significance and evidence for the existence of the æther , The London, Edinburgh, and Dublin Philosophical Magazine and Journal of Science, 33:194, 179-190, DOI: [10.1080/14786440208635625](https://doi.org/10.1080/14786440208635625)

To link to this article: <https://doi.org/10.1080/14786440208635625>



Published online: 08 Apr 2009.



Submit your article to this journal [↗](#)



Article views: 17



View related articles [↗](#)



Citing articles: 20 View citing articles [↗](#)

XIII. *On Unipolar Induction: Another Experiment and its Significance as Evidence for the Existence of the Æther.*
By E. H. KENNARD, Ph.D.*

§ 1. *Introduction.*

“UNIPOLAR induction in the general sense may be defined as induction due to motion alone.” This condition requires that the magnetic induction shall remain constant at all points fixed relative to any part of the material system involved, so as to exclude any possible effects due to a changing magnetic field; and the only form of motion satisfying this requirement is rotation about an axis of magnetic symmetry. The fundamental problem of unipolar induction is therefore this, whether the induced E.M.F. is determined by the absolute rotation of the system or by the rotation of its parts relative to each other.

Theory has answered the question in three principal ways. The oldest view, put forward by Faraday and adopted by Lorentz, refers the effects to an induced electromotive intensity given by

$$\frac{1}{c} [v \times B],$$

where B = magnetic induction and v = velocity relative to the æther (assumed stationary); the effect will therefore depend in part upon the rotation of the system as a whole. The “moving line” theory adopts the same expression, but interprets v as velocity relative to axes fixed in the material magnetic system; this view is virtually included in Neumann’s theory of electromagnetism, and is based upon complete relativity, so that the effects depend only upon relative rotation between the parts.

Experimentally, the question can be answered only by observations upon open circuits. The first investigation of this kind seems to be one made by the author †, in which an iron bar magnetized by a stationary solenoid was set in rotation inside an insulated metal cylinder connected to earth, and a charge was looked for on the cylinder due to a possible E.M.F. in the earthing wire. The result was definitely negative. Barnett’s objection ‡ that the negative result might conceivably be due to the non-rotation of the solenoid is valid, but seems decidedly weak, for it assumes a

* Communicated by the Author.

† E. H. Kennard, *Phil. Mag.* June 1912, p. 937.

‡ S. J. Barnett, *Phys. Zeits.* Sept. 1, 1912, p. 803.

radical difference to exist between induced and permanent magnetism, for which there is no other evidence; it even requires that the remanent magnetism shall not acquire the inducing properties of permanent magnetism until the magnetizing force is removed, for the remanence in the bar employed amounted to over 25 per cent. This experiment serves, therefore, to throw grave doubt upon the moving-line theory; but beyond that its theoretical significance is limited by the fact that the rotating magnet was necessarily enclosed in a second metallic screen of small diameter, and this might conceivably act so as to cut off the effect.

Fig. 1.

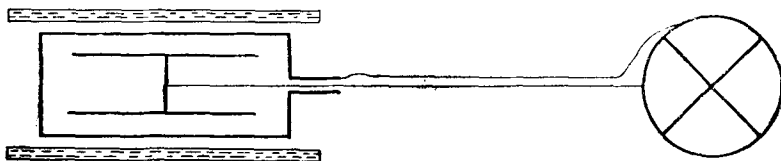

A more instructive but more difficult arrangement consists of a cylindrical condenser inside a coaxial solenoid (fig. 1), both capable of rotation about their longitudinal axis; the condenser is connected to an electrometer as shown. Let the condenser be short-circuited and set in rotation with the solenoid energized. Then according to either Lorentz's or the moving-line theory (but not according to Hertz's) the two cylinders of the condenser should come to different potentials, and the inner one at least should be charged. According to Lorentz's theory rotation of the solenoid should have no effect upon this charge. According to the moving-line theory rotation of the solenoid alone should charge the condenser in the same manner, while the condenser should remain uncharged when condenser and solenoid rotate together with no relative motion between them.

Barnett constructed an apparatus of this sort*, and showed that rotation of the solenoid alone developed no charge upon the condenser. Later, Fehrle† reported confirmatory observations with a rather different arrangement, but his work is marred by several results which must certainly be wrong: one of his results even contradicts Faraday's law for closed circuits!

Under these circumstances, while there appeared to be little doubt of the correctness of Lorentz's theory, yet the matter

* S. J. Barnett, *Phys. Rev.* Nov. 1912, p. 323.

† Fehrle, *Ann.* xlii. p. 1109 (1913).

seemed of sufficient interest to justify the attempt to obtain both positive and negative results with an apparatus like that described above, and to prove experimentally that the inner cylinder really would charge up in spite of its being enclosed by a metallic screen rotating with it.

Another apparatus has accordingly been constructed in which either the condenser or the solenoid could be set in rotation. The present paper contains an account of the work and a discussion of the theoretical significance of the result.

§ 2. Apparatus.

The condenser and solenoid are shown to scale in fig. 2, which is largely self-explanatory. All metal parts, including the base, were of brass. Guard-rings in line with the inner cylinder were introduced in order to simplify the calculation. Rotation was effected by means of a belt connected to a motor placed about 2 feet away.

Fig. 2.

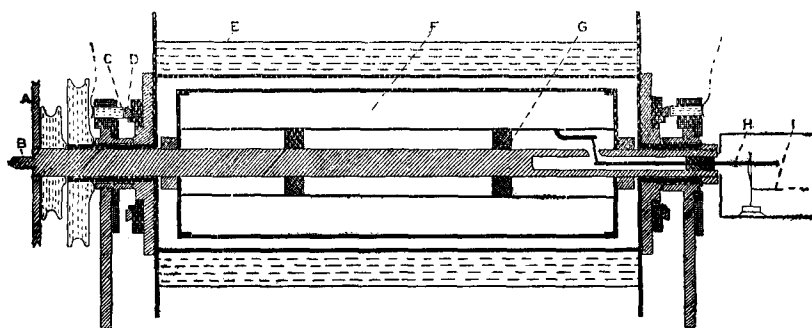

C, brush ; D, slip-ring ; E, solenoid, 22.5 cm. long, 1150 turns of wire ;
 F, condenser : outer cylinder 20.5 cm. long, 6.64 cm. in diam. ; inner
 cylinder 15.1 cm. long, mean diam. 1.54 cm., on amber rings G.
 Diam. of shaft, 1.27 cm.

The principal apparatus was earthed by a brush of brass wires sliding on the knob B, and was otherwise insulated (except for a resistance of 10,000 ohms accidentally left in place between frame and earth); the outer cylinder of the condenser is thus practically earthed at a point on the axis. In the final arrangement the needle H communicating with the inner cylinder consisted of a copper wire about 1 mm. in diameter, and was connected to the wire I leading to the electrometer by means of an insulated brush of brass wires bearing partly on one side and partly on the other. This

arrangement was satisfactory, except that sudden large disturbances were rather frequent. An earlier arrangement consisting of a steel needle running in a drop of mercury seemed rather better; the substitution was made in trying to locate a very troublesome disturbance, which was finally traced to a minute looseness of the needle. The electrometer was placed on a separate pier about 6 feet from the apparatus and in line with it, the connecting wire lying approximately along the axis. The sensitiveness was raised by means of a concave lens from 3000 to about 18,000 mm./volt at 4 m. distance; the spot could be read when stationary to 0.2 mm. Electrometer and connecting wire were carefully screened and the windings of the solenoid were connected to earth through 10,000 ohms in order to render definite any residual electrostatic effects.

No means being at hand to record the instantaneous speed of rotation, a device was adopted which gave a reading proportional to the product of field-strength and speed. A Faraday disk A was mounted on the end of the shaft, and a galvanometer giving about 3×10^{10} mm./amp. was connected through a megohm to a brush of four brass wires bearing on the bottom of the groove in the disk, and to a second brush sliding opposite the earthing brush on the knob B.

§ 3. *Method of Observation.*

Since setting the condenser in rotation caused a deflexion of several centimetres, readings were taken only by varying the magnetic field at steady speed. Let Q_1 be the charge held on the inner cylinder of the condenser by electromagnetic induction, and let Q =total charge on inner cylinder, connecting wire, and electrometer, C =capacity of this system, and V =potential of electrometer and connecting wire. Then

$$Q = Q_1 + CV.$$

If, now, the magnetic field is altered, Q_1 is altered; and if the system is insulated a deflexion of the electrometer will result corresponding to a change in its potential of

$$V = -\frac{1}{C} \Delta Q_1.$$

The usual method was to set the apparatus in rotation and insulate the electrometer; then read the spot and throw on

the current; after 20 seconds, read again and reverse the current; after another 20 seconds, read again and throw off the current; after another 20 seconds, take a final reading. This gives, by subtraction, three deflexions. The electrometer was not quite dead-beat, but reached the end of its swing in just 20 seconds; intervals of this length were marked out by a torsion-pendulum actuating a sounder. The galvanometer also was not quite dead-beat, but reached the end of its swing in 15 seconds, so its extreme position was read in each instance, giving three galvanometer deflexions likewise. Sets of readings were taken in groups of four so as to eliminate all effects that did not change sign both with the current and with the direction of rotation.

The apparent deflexion due to throwing the magnetic field on was calculated by adding twice the middle deflexion, reversed in sign, to the other two and dividing the sum by 6; drift is thus eliminated. The result is a little too large because of the underdamping; but the necessity for making a correction was avoided by taking comparison readings in exact imitation of the principal ones, using a known source of potential.

A current of 25 amp. was usually employed, and full speed was about 2000 R.P.M.

§ 4. *Calculation of Charge on Inner Cylinder.*

It is easily shown that any point of the apparatus metallically connected to earth comes to a potential of Np elmg. units, where p = rev. per sec. and N = flux encircled by the point in each revolution. Accordingly, the magnetic flux through various sections of each cylinder and the shaft was compared with that through the central section of the outer cylinder by means of a ballistic galvanometer; a null method was employed and great care was taken to eliminate stray effects. It was found that the flux through any section was proportional to the area of the section and to the sum of the angles subtended by the mean ends (radius 4.93 cm.) of the solenoid, with a maximum correction of 2 per cent., and this fact was utilized in calculating additional values.

The calculation now reduces to the solution of the following electrostatic problem: given the potentials over the bounding surfaces of two spaces each having the form of a right cylindrical shell, to find the distribution of electrification. The work was done in steps so as to avoid the solution of

more than two simultaneous equations at a time. The result for the outer space was

$$V = V_0 \{ -0.259 + 1.067 \log r \\ - \cosh(0.327x) [0.0205 J_0(0.327r) + 0.0352 K_0(0.327r)] \\ - \cosh(0.292x) [0.0027 J_0(0.292r) - 0.0111 K_0(0.292r)] \},$$

where x = distance along axis from centre, V_0 = potential at centre of outer cylinder, and

$$K_0 = J_0 \log x + \frac{x^2}{2^2} (1) - \frac{x^4}{2^2 4^2} (1 + \frac{1}{2}) \dots;$$

with a similar result for the inner space (between shaft and cylinder and guard-rings).

The charge on the insulated inner cylinder is the difference between the electric fluxes just outside and just inside the cylinder; this turns out to be $(-7.62 + 1.40)V_0 = -6.22V_0$. From the degree of accuracy of the work and the following analysis of possible sources of error, it appears that the solution result should be accurate to one-half per cent.

The residual error in the boundary values of the potential exceeded $0.003V_0$ only over the end plates and near the end of the outer cylinder, where it rose quickly to $0.04V_0$. The effect of the rather large error over the end plates may be estimated by assimilating the space to a rectangular slab and employing as an approximate harmonic the expression

$$Ae^{-\frac{\pi x}{r_2 - r_1}} \sin \pi \frac{r - r_1}{r_2 - r_1}. \text{ It is easily shown that even if } A \text{ were}$$

equal to V the effect of such a term upon the insulated cylinder would be negligible. Evidently the same must be true of the small error near the end of the outer cylinder. The connecting wire will also be charged, but the charge on the part of it inside the shaft is easily shown to be negligible by treating it as one coating of a small condenser. The longitudinal part attached to the cylinder will be at a lower potential than would exist at that point in the absence of the wire, because the potential due to induction is proportional to r^2 , while that due to the charges will contain chiefly $\log r$; hence the wire will be negatively charged. Calculation shows that the difference in potentials would be about $0.03V_0$; estimating the capacity of the wire at $2/3$ elst. unit, we have a charge on it of $-0.02V_0$.

Turning now to the amber insulators,—if the entire space were filled with amber there would be no effect upon the distribution of electrification*; but here we have to do with

* E. H. Kennard, *Phys. Zeits.* Dec. 1, 1912, p. 1155; March 15, 1913, p. 256.

short rings, and they were also flattened on opposite sides to a depth of some 3 mm. Now a rather long calculation by the method of the first article cited shows that an amber shell extending the whole length of the space and from the shaft to within 3 mm. of the inner cylinder would increase the electric flux by something like 40 per cent. In the actual case the amber extended only an eighth of the length of the insulated cylinder, and was flattened over less than half of the circumference, so that the effect could hardly exceed 2 per cent. of the flux; and this would result in an extra charge of only $0.02 \times 0.140V_0 = 0.03V_0$. This correction just about cancels the one due to the connecting wire.

§ 5. *Determination of the Theoretical Effect.*

A rough estimate of the deflexions to be expected can now be made as follows. A current of 25 amp. would produce an induction of 1600 gausses inside the solenoid, and a flux through the central section of the inner surface of the outer cylinder of about 55,400. At a speed of 33 rev. per sec. this gives a difference of $V_0 = 0.183$ volt between outer cylinder and axis; the charge on the inner cylinder will therefore be $6.22 \times 0.183 \times 1/300 = 0.114 \times 1/300$ elst. unit. The total capacity was found to be 138 elst. units; hence with a sensitiveness of 18,000 mm./volt the establishment of the magnetic field will cause a deflexion of $0.117 \times 18,000 \div 138 = 14.9$ mm. If in fig. 1 the direction of the magnetic field is from left to right and the top of the condenser is moving out of the paper, then the outer cylinder will be at a higher potential than the axis, and the inner cylinder will be negatively charged; establishment of the field will cause a deflexion of the electrometer in the direction of positive potential.

For an accurate test of theory the ratio between electrometer and galvanometer deflexions was employed. For the comparison readings a potential of $V = 0.02$ volt (about) was applied to the electrometer case, which was used as a standard inductor, and simultaneously exactly one-tenth of this was applied through the megohm to the galvanometer; by applying, reversing, and removing the potential, readings were taken in imitation of the principal ones. The electrometer readings agreed within 2 per cent., and averaged 20.5 mm., while the galvanometer deflexion was 62.2 mm. The coefficient of influence of the electrometer case had been compared previously by a null method with a good guarding condenser, whose capacity was computed to be 40.1 elst. units, and was found to be 7.42. On the other hand, the

flux through the Faraday disk was found with a ballistic galvanometer to be 0.1197 of that through the central section of the outer cylinder, so that in the main experiment the E.M.F. in the galvanometer circuit was $0.1197V_0$. Hence, by proportion, the ratio of the deflexions due to induction should be

$$\frac{20.5}{62.2} \cdot \frac{.1V}{.1197V_0} \cdot \frac{6.22V_0}{7.42V} = 0.231.$$

§ 6. *The Electromagnetic Induction Effect.*

The final results on the rotation of the solenoid alone and of solenoid and condenser locked together are shown in the annexed table. Columns S and I give the direction of rotation and the initial direction of current respectively, E and G are the electrometer and galvanometer deflexions, and R is their ratio. "Rev. av." denotes the average effect reversing with current and direction of rotation. Four sets of readings were rejected for very obvious good reason, and at once replaced; and perhaps as many more sets were not completed because of the occurrence of an obvious large disturbance. To illustrate the character of the separate readings: the three electrometer deflexions for the first line in the table were +8.5, +4.8, +3.7; for the second, +22.4, +13.8, +1.8; for the fifth, +5.1, -39.1, +3.3; for the sixth, -12.6, +29.9, -21.5.

	S.	I.	E.	G.	R.
Sol....	-	+	+ .4 mm.	+ .5 mm.	
	-	-	+ .6	- .3	
	+	-	- 1.1	- .6	
	+	+	+ 3.5	+ .2	
		Rev. av.	+ 1.2	0	
Both...	+	+	+14.4	+60.7	.237
	-	+	-15.6	-65.7	.237
	-	-	+16.4	+69.4	.236
	+	-	-18.0	-69.8	.258
					Av. .242

Final Observations.

The first group of results confirms Barnett's conclusion that the electromagnetic effect of rotating the solenoid alone is *nil*. A similar group taken previously ranged from .8 to 2.7 mm., and gave a reversing effect of only +.2 mm.

For the case where solenoid and condenser are set in rotation at the same speed and in the same direction, the mean value of the ratio 0.242 is 5 per cent. larger than the theoretical value of 0.231. But immediately after these observations a similar group of four sets taken at half speed gave a mean ratio of 0.228 (range .211 to .263), which is 1.4 per cent. too small. Then a group was taken at full speed but by a different method: in quick succession the observer threw on the current, insulated the electrometer, read the spot, and reversed the current; after 20 seconds another reading was taken and the current was turned off, and after another 20 seconds a final reading was taken. This gives two deflexions in opposite directions, a third of whose numerical sum should be the electromagnetic effect. The values thus obtained ranged from .195 to .271, and averaged 0.238; including three readings rejected because the first reading was not the greater, the average becomes 0.241. Proportionality of the effect to current strength had been tested previously; a group of four sets using 13 amp. gave a mean ratio (not comparable with the previous values) of .25, while a group taken under the same conditions, but using 25 amp., gave .27.

With the condenser alone rotating final observations were not obtained because the solenoid became short-circuited, and it was not thought worth while to rewind it. The case is, however, deducible from the other two by simple superposition; and partial confirmation is furnished by a group of observations which were taken under about the same conditions, and gave a mean electrometer deflexion of 14 mm.

The results thus remain somewhat rough, but they seem sufficient to warrant the conclusion with fair certainty that the condenser becomes charged by its own rotation in the manner required by Lorentz's theory, independently of the rotation of the solenoid.

§ 7. Fate of the Moving-Line Theory.

The view has been put forward by Poincaré *, Abraham †, and Barnett ‡ that even observations on open circuits cannot disprove the moving-line theory; and in reply to criticism by the author, Barnett maintained this view with some heat §.

* H. Poincaré, *Écl. Élect.* xxiii. p. 41 (1900).

† Abraham & Föppl, *Theo. der Elektr.* p. 420.

‡ S. J. Barnett, *Phys. Rev.* Nov. 1912, p. 323.

§ S. J. Barnett, *Phys. Rev.* Oct. 1913, p. 323.

The author yields to none in appreciation of Barnett's work on unipolar induction, and in respect for his long experience with electromagnetic theory; but on this point it seems clear that all of the writers mentioned have, through an oversight, arrived at a wrong conclusion.

The matter has been fully discussed elsewhere*, but perhaps a summary of the argument will not be amiss here. Barnett urges that an adherent of the moving-line theory must suppose the lines (*i. e.* the rotating magnetic system) to set up in the *æther* the same electromotive intensity that is caused to act upon a material dielectric, and shows from this assumption that the charges developed upon conductors would be the same whether the lines moved or not. The objection which seems to the author conclusive is that this electromotive intensity, of magnitude $\frac{1}{c}[\mathbf{V} \times \mathbf{B}]$, does not in general satisfy Laplace's equation. (The proof is simple.) In spite of this fact Barnett employs the two additional assumptions:

$$f = \frac{1}{c}[\mathbf{V} \times \mathbf{B}] + e + \mathbf{E}, \quad \dots \dots \dots (1)$$

where f = total electromotive intensity, e = electric force due to changes in the magnetic field and vanishes in the present instance, \mathbf{E} = electric force due to electrostatic causes alone; and the equation

$$\text{div}(\mathbf{K}f) = 4\pi\rho, \quad \dots \dots \dots (2)$$

where ρ = electric density.

Now in free *æther* we know from electrostatics that $\text{div} \mathbf{E} = 0$. Hence in free *æther* $\text{div} f = \frac{1}{c} \text{div}[\mathbf{V} \times \mathbf{B}]$, and may not vanish, which contradicts (2). We are thus forced to the conclusion that if the moving-line theory is correct, then the lines do not act on the *æther*, but only on material bodies, and instead of (2) we must write (with Lorentz) $\text{div}(\mathbf{K}\mathbf{E}) = 4\pi\rho$.

The real root of the matter seems to be that the *æther* cannot be treated as only a particular species of the genus "dielectric," but must be regarded as complementary to all material dielectrics. The displacement or polarization in matter does not need to be solenoidal, because its sources can be cancelled by sources of opposite sign in the displacement in the *æther*, and the total displacement may then be

* E. H. Kennard, *Phys. Rev.* May 1913, p. 355.

solenoidal. But free æther has no such means of self-defence, and consequently all forces acting on it must themselves be solenoidal.

The moving-line theory seems therefore to be definitely disposed of by the results obtained by Barnett, Fehrle, and the author.

§ 8. Conclusion.

The practical bearing of these experiments is small, yet they do necessitate a correction of certain statements that are common in the textbooks. For instance, it is not correct to say that the effect of rotating the armature of a dynamo is the same as that of rotating the field-magnets in the opposite direction. The *total* E.M.F. is the same, but in the first case it is developed almost entirely in the longitudinal parts of the winding, while in the second case a large fraction of it is developed in the radial parts, and the distribution of electrification on the armature will be different.

The most interesting case theoretically is that where the solenoid and condenser rotate together at the same speed. The charging up of the condenser cannot be conditioned by rotation relative to the connecting wires and electrometer. For suppose that the sliding contacts had been exactly on the axis, which was nearly true, and that they were connected by an axial wire extending through the condenser so as to form a closed circuit. Then it is certain, by Faraday's law, that rotation of the connecting wires and electrometer would cause no deflexion of the latter; and this negative result can hardly be due to an E.M.F. in the axial wire which was added. Rotation relative to the earth might in some unknown way be responsible for the observed effect, but this seems improbable. If we reject this assumption, then the effect is due to an absolute rotation in the same sense in which the operation of a gyrocompass is due to an absolute rotation of the earth.

But rotation of the whole is essentially only translation of the parts. We must suppose each electron in the condenser to experience a radial force proportional to its distance from the axis; and it is interesting to inquire what can cause such a force. It cannot be due either to the radial acceleration, for that is proportional to the square of the distance, nor to a possible rotation of the electron about its axis, for that should be the same for all electrons, nor to their motion relative to other essential parts of the apparatus, for there is no such motion. Apparently the only remaining alternative is to ascribe the force to motion of the electrons relative to

something which is not matter, and which does not share in the rotation of the condenser, and this something must be the stationary æther of Lorentz.

This phenomenon seems therefore to lend definite support to the existence of an electromagnetic æther. It is, perhaps, the only low-frequency phenomenon which cannot easily be described in terms of "action at a distance" between electrons and atoms. It seems, for this reason, to have some importance as a stumbling-block in the way of those ultra-relativitists who would abandon the conception of an æther altogether.

Summary.

An experiment is described showing that a cylindrical condenser rotating inside a magnetized coaxial solenoid becomes charged as required by the theory of Lorentz. Rotation of the solenoid has no effect (Barnett).

The disproof of the moving-line theory is thus completed; electromagnetic induction depends in part upon absolute rotation in the mechanical sense. Analysis in terms of electrons seems to make necessary the existence of a stationary æther in order to explain the observed effect; so that the phenomenon seems to present difficulties for those relativitists who reject the æther.

It is a pleasure to acknowledge obligations to Mr. Christian Dane, mechanician, whose share in the construction of the apparatus left nothing to be desired; and to Professor Henry A. Erikson for his kindly interest and advice during the progress of the work.

University of Minnesota,
August, 1916.

XIV. *The Limits of Inflammability of Gaseous Mixtures.* By W. M. THORNTON, D.Sc., D.Eng., Professor of Electrical Engineering in Armstrong College, Newcastle-upon-Tyne*.

1. **T**HE ignition of an inflammable gas mixed with air depends in a variety of ways upon the proportion of oxygen present. With impulsive sparks or condenser-discharge the ignition passes through critical stages when the ratios of the number of oxygen atoms to one molecule of

* Communicated by the Author.