

D.M.ranaea

НЗМЕРЕННЕ

схОРОСТН Зsn оро БЕТРА

Н КННЕМАТНВЕКОН

БРЗКОСТН З@NPA

ОНТНВЕКНМ

ННТЕР@ЕРОМЕТРОМ



ООО "Н оóаух"
ХаpaKOB - 2007

UDC 530.3 Galaev: 1

BBK 22.3.

Г1

Galaev Y. M.

Г1 Measurement velocity etheric wind and kinematic viscosity of ether by optical interferometer. - Kharkov: LLC "Infobank", 2007, 44 pp. ill. 9

ISBN 978-966-8464-07-2

Experimental verification of the ether hypothesis was carried out. The results of systematic studies were compared with the results of previous studies carried out in the radio and optical wave ranges. The kinematic viscosity of the ether was calculated and measured. The results of the experiment do not contradict the provisions of the original hypothesis and can be regarded as confirmation of the statement about the existence of the ether in the Earth. The negative results of the May-Kelson-Morley experiments are explained by the insufficient sensitivity of the measuring devices.

Published in the author's edition

ALL RIGHTS RESERVED AND PUBLISHER'S RIGHTS RESERVED.

REPRINTING, CREATION OF ELECTRONIC COPIES AND OTHER PUBLICATION OF THE BOOK AND ITS CONTENTS WITHOUT THE WRITTEN CONSENT OF THE PUBLISHER IS PROHIBITED.

THE REFERENCE IS OBLIGATORY.

g 1705010000 -19
8464 - 2007

Unadvertised.

BBK 22.3.

ISBN 978-966-8464-07-2

OGyuaevYu.M "200b

Preface.....	4
Introduction.....	5
1. Experimental prerequisites.....	7
2. Measurement method.....	10
3. Kinematic viscosity of ether.....	20
4. Optical interferometer.....	21
5. Interferometer testing.....	26
6. Measurement of the kinematic viscosity of ether.....	29
7. Metrological properties of the interferometer.....	29
8. Measurement methodology.....	30
9. Processing of measurement results.....	31
10. Measurement results.....	31
Conclusion.....	40
Literature.....	41

Preface

The broivure continues the discussion of the otyaese experiment undertaken by the author in 2001-2002 rr. to study the problem of the ether wind. Some results of the experiment were published in the journal "Spacetime & Substance":

*Galaev Yu. M. THE MEASUREMENT OF ETHER-DRIFT
VELOCITY AND KINEMA TIC ETHER VISCOSITY WITHIN
OPTICAL PATHWAYS*

*BAND //Spacetime Substance, 2002. Vol.3, No.5(1S). -
P.207-224.*

The text of the article in English can be found on the journal's website at <http://www.spacetime.narod.ru/0015-pdf.zip>. Subsequent research was primarily concerned with the development of the theory and technique of this experiment. Additional tests of the stability of the optical measuring device with respect to external influences were performed. It has been shown experimentally that pipes made of dielectric materials are as directional systems for ether flows as metallic pipes. Previously, it was believed that only metal pipes had this property. The discovered phenomenon was explained in the framework of filtration laws. The results of the research allowed us to develop the experimental theory. Measurements of the dependence of the aether wind velocity on the height above the Earth's surface showed that at a height of 1.6 m the aether wind velocity does not exceed 200 m/sec and grows with increasing height. This result allowed us to suggest a possible reason for the negative results of the well-known experiments of Michelson (1881) and Ntaikelson-Morley (1 887), in which interferometers built according to Michelson's cross-shaped scheme were used. It is shown that Michelson and Morley would have needed interferometers with the length of light rays of about 54000 m to detect the motion of the ether at a speed of 200 m/sec. In the 1887 experiment, the length of the light rays was reduced to 22 m, and the interferometers were placed in basement rooms. Consequently, in the experiments of Michelson and Morley, the measuring devices had insufficient sensitivity to detect the phenomenon, the existence of which was not doubted by the pioneers of these studies. Later, already in 1921-1926, their hopes seemed to be justified by the positive results of D.K. Miller's experiments. However, in subsequent experiments, Miller's results were not confirmed and were considered erroneous. The ether hypothesis was rejected. It seemed to be definitive. Nevertheless, the analysis of the work of his followers.

Miller showed that in all attempts, with a detrimental outcome, in one way or another, there were metal screens covering the optical paths of the measuring devices. Such an analysis was first performed by Miller in his final paper of 1933. The conjecture was confirmed by Michelson's experiment of 1929, in which no metal screens were used, and a result was obtained which, on the whole, did not contradict Miller's data. Perhaps because of the small statistical significance of the 1929 experiment, physicists did not give it the attention it deserved, nor did they take into account Miller's recommendation not to use metal screens. The experimenters continued to idealize the properties of ether, the first of which was the property of all-permeability of its flows. Within the framework of such an assumption, metals should not provide any obstacle. This was the source of repeated instrumental errors.

In the second half of the 20th century, taking into account the available experimental material and new knowledge about nature, there were opportunities to return to the ether hypothesis. Perhaps, the greatest development of ideas about the properties of the ether and various forms of its motion was achieved in Russia, in the works of V.A. Aiyukovsky. It was convincingly shown that the ether has the properties of an ordinary gas, possessing viscosity, compressibility, temperature, pressure, and the laws of gas dynamics are fully applicable to the ether. Such representations opened the possibility to apply the methods and devices of measurements, the action of which is based on the known regularities of the flow of viscous media. This made it possible, in comparison with the Michelson interferometer, to raise the sensitivity of measuring devices by several orders of magnitude and, in addition to velocity measurements, to measure the kinematic viscosity of ether for the first time in an expert manner. In addition to the description of the optical excursion, the brochure also presents results obtained in the milliwave radio range for comparison. The results of the experiments in the radio and optical wave diapasons, together with Miller's results, show the observability, reproducibility, and repeatability of the ether wind effects in experiments conducted in different ranges of electromagnetic waves, by different methods of measurement, and in different geographical conditions. The results of the study do not contradict the provisions of the original hypothesis and can be regarded as an expert confirmation of the ideas about the existence in nature of the ether - the material medium responsible for the propagation of electromagnetic waves.

Introduction

Earlier, in the works [1-3], in the range of milliwave radio waves, the expert test of the hypothesis of the existence of the following hypothesis was performed using the phase method

In the course of the experiment [1-3], V.A. Atsyukovsky's model of a viscous gas-like aether was adopted as the initial hypothesis [4-6]. In setting up the experiment [1-3], the model of a viscous gas-like ether by V.A. Atsyukovsky [4-6] was adopted as the initial hypothesis. The results of systematic measurements showed the following: the propagation of radio waves is anisotropic, the magnitude of anisotropy increases as the height above the Earth's surface increases, and the magnitude of anisotropy changes with a period of one stellar day. The detected effects are explained by the phenomenon of radio wave propagation in a moving medium of cosmic origin with a vertical velocity gradient in the flow of this medium near the Earth's surface. The presence of the gradient layer can be explained by the viscosity of this medium, a property inherent in material media, i.e., media consisting of individual particles. The measured values of the velocity of motion of the assumed medium are compared with the results of experimental works [7-9] and [10], which are performed in the range of optical waves with the analogous purpose - experimental verification of the hypothesis of the existence of ether in nature. It was obtained that in experiments [1-3] the velocities of the medium motion, reduced to the conditions of experiments [7-9] and [10], lie within the range of 6120 ... 8490 m/sec. 8490 m/sec, which in order of magnitude corresponds to the data of works [7-9] and [10], which lie within the limits of 6000... 10000 m/sec. The result of the comparison can be regarded as a mutual confirmation of the reliability of experiments [1-3], [7-9], and [10]. The results of three experiments [1-3], [7-9] are presented here,

[10] gave grounds to consider the effects found in these works as manifestations of the motion of the medium responsible for the propagation of electromagnetic waves. In the times of D.C. Maxwell, A.A. Michelson, and earlier, such a hypothetical medium was called the ether [11]. In [1-3] it is shown that the results of the experiment in the range of millimeter radio waves do not contradict the original hypothesis [4-6]. It is concluded that the results of the study can be regarded as an experimental confirmation of the hypothesis of the existence of such a material medium as ether in nature. Further judgments of the experimental results [1-3] showed the advisability of additional experimental study of the problem of the ether wind in the optical wavelength range.

The purpose of this work is to experimentally verify, in the optical wave range, the hypothesis of the existence in nature of the ether, a material medium responsible for the propagation of electromagnetic waves. The second goal of this work is to measure the kinematic viscosity of the ether. Thus, the present work is a logical continuation of the studies carried out in the radio wave range. In order to achieve the goals of the work, the following basic tasks should be solved.

- *Take into account the shortcomings* of earlier experiments.
- *To develop and revise an optical measurement method* and a measurement device that do not repeat Michelson's scheme, but are its analogs in terms of interpretation of measurement results. (Michelson's second-order interferometer is insensitive to ether currents and too sensitive to extrinsic effects.).
- *Perform systematic measurements* at the time of the year corresponding to the epochs of the previous experimental work [1-3], [7-9], [10]. (The term "epoch" is derived from astronomy, in which observations of different years made in the same months are considered to be observations of the same epoch).
- *The results of the study should be compared with the results of previous experimental work.* This will make it possible to establish the conformity of the research results to the criteria of *observability* of the phenomenon, its *repeatability* in different conditions of observation, its *reproducibility* when using different methods of research and will give grounds both for assessing the reliability of the research results and for the conclusion about the experimental support of the hypothesis about the existence in nature of such a material medium as ether.

1. Experimental prerequisites

In [4-6], the ether is represented as a material medium consisting of individual particles that fills the world space. The ether has the properties of a viscous and compressible gas. Physical fields represent various forms of ether motion, i.e. ether is the material medium responsible for the propagation of electromagnetic waves. The experimental basis of the model [4-6] was, first of all, the positive results of the search for the ether wind published in the literature

D.K.Miller in 1922-1926 rr. [7-9] - A.A.Michelson, F.G.Pease, F.Pearson in 1929. [10].

The experiments [7-9] and [10] were performed with the help of optical interferometers made according to the transformed Michelson scheme [12,13]. The sensitivity of the Michelson interferometer to the desired effects of the ether wind was low, which was a consequence of the very principle of operation of such a device, based on the passage of light in the direct direction and its return to the observation point along the same path. In this case, what the beam of light gains from the etheric wind in the direct direction, it will lose almost everything when traveling in the reverse direction.

direction. In such a device, the measured value D - the visually observed displacement of the interference pattern fringes, expressed by the number of fringes, is proportional to the square of the ratio of the ether wind speed v to the speed of light c , to the length of the light beam in the measuring part of the interferometer, and inversely proportional to the light wavelength λ [12].

$$D = (f / d)(v / c)^2 . \tag{1}$$

In the ether wind experiments, research methods and experiments in which the measured value is proportional to $(v/c)^2$ are called "second-order methods and experiments". Accordingly, the methods and experiments in which the measured value is proportional to the first degree of the v/c ratio are called first-order methods and experiments. When the value of v - 30000 m/sec expected in the experiments (7-10, 12,14), the v/c ratio $\ll 1$. In these conditions, the second-order methods are ineffective. So at $v = 30000$ m/sec the second-order methods are 10^4 times inferior in sensitivity to the first-order methods and, for example, at $v = 200$ m/sec this number reaches already $1,5 \cdot 10^4$. Consequently, at relatively low velocities of the ether wind, the second-order methods are practically insensitive to the effects of the ether wind, and in such conditions experimental studies are possible only with the use of the first-order methods.

The expression (1) allows us to estimate the difficulties encountered by the ether wind researchers in their first attempts to observe second-order effects. Thus, in Michelson's well-known first experiment of 1881 [12], with the assumed knowledge of the velocity of the aether wind. [12], at the assumed knowledge of the aether wind velocity $v = 30000$ m/sec, using an interferometer with parameters: $l = 6 \cdot 10^1$ m; $d = 2.4$ m, it was expected to observe a value of $D = 0.04$ fringes. This attempt had to be made under conditions of significant fringe jitter in the interference pattern. In [12] Michelson noted: *"Under ordinary conditions the fringes were very indistinct and difficult to measure; the instrument was so sensitive that even a shuui on mpomyape a hundred meters from the observatory was the cause of the complete disappearance of the fringes!"* Later, in 1887, Mackelson, also in his world-famous paper [14], in collaboration with E.W. Morley, once again noted the shortcomings of his first ether wind experiment: *"In the first experiment, one of the main difficulties considered was the rotation of the annapama without distortion, the other was its exceptional sensitivity to vibrations. The latter was so great that it was impossible to see interference fringes, except at short intervals while working in the city, even at 2 o'clock in the morning. Finally, as noted earlier, the quantity to be measured, namely, the displacement due to something of the interference fringes by a distance less than 1/20 of the distance between them, is too great to be measured."*

The "A" is not sufficient to determine it, but even with the imposition of experimental errors".

To increase the sensitivity of interferometers, researchers increased the length of light rays. Thus, in the Miller interferometer, the length of the rays was increased to 64 meters, which was possible due to the use of multiple reflection of light in the arms of the interferometer. The actual length of the arms was reduced to 4 meters [7-9]. In the experiment [10] used an interferometer with a light ray length of 52 meters. To eliminate mechanical interference, the interferometers rested on rafts placed in mercury tanks.

The experiment [7-9] was characterized by careful preparation, verified research methodology, and statistically significant measurement results. The measured parameters of the aether wind did not correspond to the then-current ideas *about* the aether as a static medium with ideal properties. The orbital component of the velocity of the ether wind, due to the Earth's motion around the Sun at a speed of 30000 m/sec, was not detected. Miller obtained that the velocity of the ether wind at a height of 265 m above sea level (Cleveland, USA) has a value of about 3000 m/s, and at a height of 1830 m (Mount Wilson Observatory, USA) - about 1-10 m/s. The coordinates of the aether wind were determined. The coordinates of the apex of the solar system motion were determined: direct ascent $e = 17.5$, declination $\delta = +65^\circ$. This motion is perpendicular to the ecliptic plane (coordinates of the north pole of the eusitgeek: $\alpha = 18$, $\delta = +66^\circ$). Miller showed that the observed effects can be explained if we assume that the aether flow has a cosmic (galactic) origin and a velocity of more than $2 \cdot 10^5$ m/sec. Against this background, the orbital component of the velocity is fading. The decrease in the velocity of the ether wind from $2 \cdot 10^5$ m/s to $1 \cdot 10^4$ m/s was attributed by Miller to unknown causes.

The positive results of Miller's expert, because of their general physical significance, have attracted much attention. In the monograph [15] reports about 150 papers devoted to the problem of the ether wind, dating from 1921 to 1930, which almost all focused on the discussion of Miller's results. The most widely *discussed* in these works was the possible influence of external causes (temperature, pressure, solar radiation, air currents, etc.) on the new cross-shaped interferometer, which had significant dimensions in Miller's results [16]. However, the most important reason that made Miller's contemporaries consider his experts to be unreliable was that Miller's results were not confirmed in numerous subsequent works, such as [17-20]. In [17-20], the so-called "null results" were obtained - no ether wind was detected.

In 1933, D.K. Miller, in his final paper [21], performed a comparative analysis of numerous unsuccessful attempts to detect the ether wind. He drew attention to the fact that in all such attempts, except for the experiment [10], optical interferometers were placed in hermetic metal chambers. With the help of such chambers, the researchers tried to shield the devices from external influences. In experiment [10], the interferometer was placed in the fundamental building of the optical workshop of the Mount Wilson Observatory to stabilize its temperature regime. A sealed metal chamber was not used, and the ether wind was detected. It had a velocity of 6000 meters per second. This gave Miller the reason to conclude: *"When investigating the question of ether entrainment, the presence of massive impermeable screens is undesirable. The experiment ... should be constructed so that there were no screens between the free ether and the light path in the interferometer"*.

Later, after the appearance of devices based on completely different ideas (resonators, masers, the Mössbauer effect, etc.), new opportunities for conducting experiments to detect the ether wind appeared. Such experiments were carried out [22-25]. Again, the common instrumental feature of these experiments was the use of massive metal chambers. In [22,23,25], these were metal resonators, and in [24], a lead chamber, since gamma radiation had to be used. The authors of these works, apparently, did not give due importance to Miller's 1933 conclusions about the inapplicability of **massive** screens in experiments on the aether wind. Atsyukovsky first tried to give a physical interpretation of the phenomenon of a significant decrease in the velocity of the ether wind in the presence of metal screens, explaining the large ether-dynamic resistance of metals by the presence of their Fermi surface [6].

Thus, taking into account the shortcomings of the works [7-9], [10] and the existence of a large number of experiments with zero results, one can understand the distrust of physicists of that time in the works [7-9], [10], the results of which pointed to the necessity of changing the fundamental physical endings, which eventually **led** physicists to reject the ether **endings**. An analytical review of the most significant experiments performed to search for the ether wind is presented in [1-3, 26].

2. Sighing method

When setting the experti vation, the ether model proposed in [4-6] was adopted as the initial hypothesis. Within the framework of the initial hypothesis

The following effects can be expected in light propagation experiments near the Earth's surface.

Anisotropy effect - the speed of light depends on the direction of emission, which is due to the relative motion of the observer and the ether, the medium responsible for the propagation of electromagnetic waves.

Altitude effect - the magnitude of anisotropy **increases** as the altitude above the Earth's surface increases, which is due to the interaction of the Earth's surface with the flow of viscous ether, the material medium responsible for the propagation of electromagnetic waves.

Cosmic effect - the magnitude of anisotropy changes with a period of one stellar day, which is caused by the **c o s m i c** (Galactic) origin of the ether wind. At the same time, due to the daily rotation of the Earth and the Earth's movement along its orbit, the height (astronomical coordinate) of the Solar System's apex will, like the height of *your* star, change its value with a period of one stellar day. Therefore, the value of the horizontal component of the ether wind velocity and, consequently, the magnitude of anisotropy will change their values with the same period. **Hydrodynamic effect** - the speed of light depends on the parameters of viscous gas-like ether motion in guiding systems (e.g., pipes), which is caused by the interaction of solid bodies with the ether flow - the material medium responsible for the **propagation of** electromagnetic waves.

According to the objectives of the study, the measurement method should be sensitive to these effects, and the measuring device should not repeat the scheme of the Michelson interferometer, which is caused, as noted above, by the low sensitivity of the Michelson interferometer to the anisotropy effect. The following provisions of the f4-dJ model were used in the development of the measurement method.

is the material medium responsible for the propagation of elect-

The aether has the properties of viscous rasa; metals have a large aether-dynamic resistance. The idea of the existence of the hydrodynamic effect is accepted as a starting point.

In the present work, a first-order method based on the well-known regularities of viscous gas motion in pipes [27,28] is proposed and implemented in the optical range of electromagnetic waves to measure the velocity of the ether wind and the kinematic viscosity of the ether. The principle of operation can be explained as follows. Let us place a section of pipe in the gas flow so that the longitudinal axis of the pipe is perpendicular to the flow velocity vector. In this case, both open ends of the pipe are in the same conditions with respect to the **external** gas flow. There is no gas pressure drop at the ends of the pipe and the gas inside the pipe will be stationary. Now we rotate the pipe so that the velocity vector-

The gas flow velocity is directed along the axis of the pipe. In this case, the gas velocity head will create a pressure drop at the pipe ends, under the action of which a gas flow develops in the pipe. The time of gas flow development in the pipe and the speed of steady gas flow are determined by the values of kinematic viscosity of gas, geometrical dimensions of the pipe, and the velocity of the internal gas flow [27,28]. It is important to note that the development of gas flow in the pipe up to the steady-state value of the flow velocity takes a finite period of time. The considered idea makes it possible to propose a measurement method sensitive to the anisotropy of the light velocity and a scheme of a device for measuring the anisotropy and kinematic viscosity of the ether. Thus, according to the accepted hypothesis, the ether is a **gas-like** material medium responsible for the propagation of electromagnetic waves. This means that the velocity of an electromagnetic wave relative to the observer is the sum of the vectors of the wave velocity relative to the ether and the ether velocity relative to the observer. In this case, if we construct an optical interferometer in which one beam is inside a hollow tube and the other outside the tube, in an external ether flow, and turn the interferometer in the ether wind flow, we can expect that in such an interferometer, during the time of installation of the ether flow in the tube, a displacement of the interference fringes relative to the initial position of these fringes on the interferometer's yukul should be observed. In this case, the value of the displacement of the fringes will be proportional to the velocity of the external ether flow, and the time of the return of the fringes to their initial position will be determined by the value of the kinematic viscosity of the ether. Consequently, the proposed measurement method makes it possible to measure the values of the ether wind velocity and the kinematic viscosity of the ether. The proposed measurement method and device is a first-order method and device because it is not necessary to return the light beam to the starting point, as, for example, in the Michelson interferometer.

In order to quantitatively evaluate the possibility of realizing the proposed measurement method and calculating the design parameters of the measuring device, to analyze the flow of gas-like ether in pipes, we will use the mathematical algorithm of hydrodynamics, which was developed in [27,28] when solving problems related to the flow of viscous incompressible fluid. In other words, in the present work, the analysis of the flow of a gas-like ether is limited by the following condition

$$0.5Ma' \ll 1, \quad (2)$$

where Ma' - w_{pc} , o' is the Maxa number; w_y is the average gas velocity along the pipe cross section; c , is the sound velocity in the gas. If the condition (2) is satisfied, we can neglect the effects of gas compression and consider the gas flow as the flow of a non-compressed liquid.

In hydrodynamics, there is a distinction between freezing and turbulent flow

fluid. Laminar fluid flow exists if the Reynolds number Re computed for the flow does not exceed some critical value Re_c [27,28]

$$Re < Re_c \quad (3)$$

The Reynolds number for a circular cylindrical pipe is determined by the following expression [27,28]

$$Re = 2a_p w_{pa} \nu^{-1}, \quad (4)$$

where a_p is the internal radius of the pipe; ν is the kinematic viscosity of the liquid; μ is the dynamic viscosity; ρ is the density of the liquid. Depending on the character of external flow and conditions of liquid flow into the pipe, the values of Re lie in the range of $Re = 2, 3 \cdot 10^3 - 10^4$. At

$Re < 2.3 \cdot 10^3$ liquid flow in the tube exists only as laminar flow and does not depend on the degree of turbulence of the external flow. The laminar fluid flow in a circular cylindrical tube is characterized by the following features. The trajectories of the particles are rectilinear. The **maximum velocity of the liquid flow** $w_{p \max}$ takes place along the axis of the pipes and is equal to [27,28]

$$w_{p \max} = 0,25 \Delta p a_p^2 \mu^{-1} l_p^{-1}, \quad (5)$$

where Δp is the pressure drop on the pipe section of length l_p , the maximum velocity of the flow is twice as large as the average velocity of the liquid

$$w_{p \max} = 2 w_{pa}; \quad (6)$$

the distribution of flow velocities along the pipe cross section is given by the Poiseuille parabola and is as follows

$$w_p(r) = w_{p \max} (1 - r^2 a_p^{-2}), \quad (7)$$

where r is the coordinate along the radius of the pipe.

The transition of laminar flow into turbulent flow occurs by a jump. The turbulent flow of viscous fluid in a circular cylindrical tube is characterized by the following features. The trajectories of the particles are disorderly. The velocity distribution along the pipe section is almost uniform with a sharp decrease to zero in a thin layer near the wall. The excess of the maximal flow velocity over the average velocity is of the order of 10-20% [27,28].

$$p'(11112)p \quad (8)$$

It is shown below that under the conditions of the experiment $Re > Re_c$, therefore, in the present work we will limit ourselves to the estimates made for the turbulent ether flow.

Fig. 1 shows a section of a round cylindrical metallic tube of length l which is in the flow of ether (ether wind). The direction of the flow is shown in the figure by slanting thin lines.

The longitudinal axis of the tube is horizontal. The longitudinal axis of the tube is horizontal and together with the ether wind velocity vector lies in the vertical plane, which is represented by the plane of the figure. The walls of the tube have a large ether-dynamic resistance and the ether flow acting from the side of the tube does not move the ether inside the tube. The velocity pressure of the ether due to the horizontal component of the ether wind velocity Oh , creates in the tube a flow of ether which moves with an average velocity w_p . It can be said that the metallic tube is a

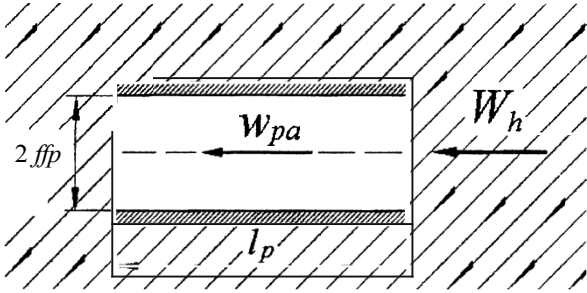

Figure 1. Pipe in gas flow

is a guide system for the flow of ether. **Let us turn the tube** in the horizontal plane so that its longitudinal axis takes a position perpendicular to the plane of Fig. 1 or, similarly, perpendicular to the velocity vector of the ether wind. In this position both open ends of the tube will be in the same conditions with respect to the ether flow.

According to expression (5) the velocity of ether flow in the tube is equal to zero. At time rt , we turn the tube to the initial position. In this case, the open ends of the tube are in different conditions with respect to the ether flow. The horizontal component of the ether wind velocity Oh will create a pressure drop Ar at the pipe ends, under the action of which the ether flow will develop in the pipe. In [28], the problem of the motion of a viscous incompressible liquid resting in a circular cylindrical tube under the action of a suddenly applied constant pressure drop Dr is solved. The expression describing the distribution of velocities of the fluid flow in the tube has the following meaning

$$w_p(r, t) = w_{p \max} \left[1 - \frac{r^2}{a_p^2} - \sum_{k=1}^{\infty} \frac{0(\psi_k r a_p^{-1})}{\psi_k^3 J_1(\psi_k)} \exp\left(-\frac{V \psi_k^2}{a_p^2} t\right) \right], \quad (9)$$

where i is time; ok are the roots of the equation $J(g'i)$ $0; fo' i$ are the Bessel functions of the yule and first orders. The first two summands in square bracket

express the steady (at $t \rightarrow \infty$) laminar flow of the fluid and correspond to the above mentioned "Poiseuille parabola" (7). Since at turbulent flow of the liquid, according to expression (8), the distribution of velocities over the pipe cross-section is almost uniform, we will consider that, except for a thin wall layer, the velocity of the liquid flow over the whole pipe cross-section is equal to w_{pa} . In this case expression (10), at $g = 0$, will take the following form

$$w_p(t) \approx w_{pa} \left| 1 - 8 \sum_{k=1}^{\infty} \psi_k^{-3} J_1^2(\gamma_k) \exp\{-v_{\gamma_k} a^2 t\} \right|. \quad (10)$$

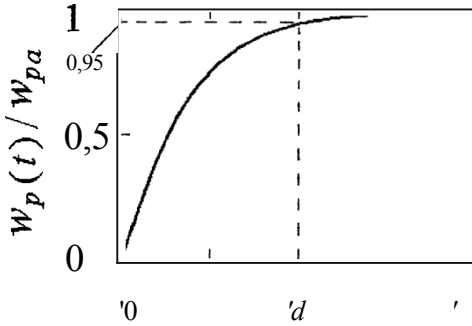

Figure 2. Time variation of **liquid velocity in the pipe**

Expression (10) describes the time evolution of liquid motion in a round tube. It follows from expression (10) that at $g = y = m$ the value $pp) \quad pq$. Let us divide both parts of expression (10) by the value of the steady-state velocity of the liquid flow in the round tube w_y . Fig. 2 shows the change in time of the dimensionless velocity of the fluid flow in a natural form. On the ordinate axis are plotted the values of the dimensionless velocity $Shchr t) / r$, on the abscissa t . In accordance with the initial hypothesis, within the framework of condition (2), we will further speak about the ether flow rather than the fluid flow. In Fig. 2, I highlighted the time segment $to 'd$, during which the dimensionless velocity of the aether flow in the tube varies from 0 to 0.9f $FWrp$. We will call the aether flow regime at this time interval dynamical. The flow regime at $t > td$ will be called the steady-state regime of the ether currents.

Let us pass a beam of light along the axis of the tube. It can be written that the phase of the light wave on the segment of length Jp will change by the value $'g$, which is equal to

$$' 2fp \quad ' \quad)$$

where f is the frequency of the electromagnetic wave; K is the speed of light in the tube. Co-

According to the following hypothesis, the ether is the medium responsible for the propagation of electromagnetic waves. It follows that if in a pipe of length l_p there is an aether flow whose velocity varies in time, then the phase of the light wave measured at the exit of the pipe must vary in time in accordance with the time variation of the velocity of the aether flow W_p . Then expression (11) takes the form

$$\varphi(t) = 2\pi f l_p [c \pm w_p(t)]^{-1} \quad (12)$$

where c is the speed of light in the stationary ether, in vacuum. In expression (12) the sign "+" is applied when the direction of light propagation coincides with the direction of the ether flow in the tube, and the sign "-" when these directions are

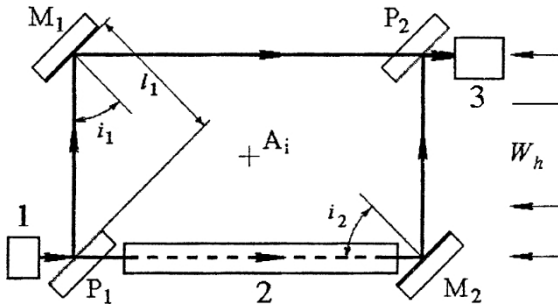

Fig.3. Schematic diagram of the optical interferometer

In the present work, an optical interferometer is used to measure the value of $\langle v \rangle$. The scheme of the interferometer of Rozhdestvensky [29] was taken as a basis and supplemented by the fact that in one of the arms the light beam runs along the axis of a hollow metal tube. The scheme of the tube interferometer and its main nodes are shown in Fig. 3. The scheme shows: 1 - illuminator; 2 - section of a metal tube; 3 - eyepiece with a mirror; Pt, P, - plane-parallel translucent plates; M, Me - mirrors.

The course of the rays is shown by thick lines with arrows. The rays of light in the tube

runs along its axis and is indicated in the figure by a dotted line. The length l_p

The nodes P, M and Pt, Me are set in parallel to each other. M1, M2 are set with respect to each other at a small angle. The angles α, β - between the normals to the planes of the mirrors of M1, M2 and the rays incident on them. Distances $PtM = M2P$

In the classical case, if we do not take into account the influence of the ether wind, the action of the interferometer is reduced to the following. A ray of light with wavelength d is split by Pt into two rays, which, after reflection from M1 and M2, are recombined at Pt. The deposits appear to be parallel with the phase difference [29]

$$f' = 4v f d'' (\cos i_1 - \cos i_2) \quad (13)$$

The angles $it, 32$ are set when adjusting the interferometer so that the interference pattern is observed in the eyepiece 3. (The adjustment nodes are not shown in the diagram.) In the adjusted interferometer the value of $\nu = \text{const}$. In the right part of Fig. 3, the family of arrows denotes the motion of the horizontal component of the ether wind velocity. The velocity of this motion is equal to hy . If we place the nodes of the interferometer on a horizontally rotating base, such a device can be rotated in the ether flow. The axis of rotation is perpendicular to the plane of the figure and is denoted as $A, .$

Рассмотрим действие интерферометра с трубой (рис. 3) в потоке эфира. Положение полос интерференционной картины относительно юканы окуляра 3 определяется разностью фаз лучей света, которые распространяются по путям РИМ Р « Р М, На рис. 3 поток эфира направлен навстречу направлению распространения света вдоль лучей РтМ₂, М > В этом случае, учитывая выражение (12), найдем разность фаз $b \Delta(t)$ между лучами М Р » РтМтР_Z

$$\Delta\varphi(t) = 2\pi f \left\{ \frac{P_1 M_2 + M_2 2 2}{p(t)} - \left(\frac{P_1 M_1}{c} + \frac{M_1 P_2}{c - W_h} \right) \right\} + \delta, \quad (14)$$

where δ is a constant value, the value of which is determined by the expression (13). Let us simplify expression (14). For this purpose, we introduce the notation adopted above. Then, taking into account that the phase difference of the rays $M_2 - P_1M$ does not depend on the orientation of the interferometer with respect to the direction of the ether flow and is equal to zero, expression (14) will be given as follows

$$\Delta\varphi(t) = 2\pi f l_p \left(\frac{1}{c - w_p(t)} - \frac{1}{c - W_h} \right) + \delta. \quad (15)$$

The first term of expression (15) denotes the change in the phase of the ray P M, in the dependence on the velocity of ether motion in the tube $w_p(t)$, the second - the change in the phase of the ray M; 2 " of the dependence on the velocity of the external ether flow $+h$ Let us bring the expression in square brackets to the common denominator $c^2 \gg W_h w_p(t) - c w_p(t) - c W_h$, $f c^{-1} = \lambda^{-1}$ получим

$$\Delta\varphi(t) \approx \frac{2\pi l_p}{\lambda} \left| \frac{w_p(t) - W_h}{c} \right| + \delta. \quad (16)$$

It follows from (16) that the phase difference $\Delta\varphi(t)$ between the rays M_2 and P_1M is proportional to the velocity difference of the ether flow in the tube $w_p(t)$ and the external ether flow W_h .

Let us consider the action of the interferometer with the tube in the steady-state mode of its operation, at f -g m. According to expression (10) and Fig. 2, $w_p(t) = a - g w_p$. It can be assumed that, due to the small value of the

dynamic viscosity of the ether (celestial bodies move in the ether without any noticeable-

The velocity of the established aether flow in a tube of relatively short length will not differ appreciably from the velocity of the external aether flow and it can be written that

$$p) ' p ' h \tag{17}$$

Such an assumption in the paper is verified experimentally, which is shown below in the "interferometer test" section. In this case, in the expression (16) the numerator of the fraction in square brackets is zero, and expression (16) takes the form

$$\text{Ar}(/),_{s,q} - 6 \tag{18}$$

Consequently, in the steady-state regime, the action of the tube interferometer does not differ from that of the Rozhdestvensky interferometer. In both interferometers, the **position of the fringes of the** interference pattern will be determined by the initial phase difference $\#$. The *tube* interferometer in the steady-state **mode is not sensitive to the ether** wind velocity and cannot detect the presence or absence of the ether wind.

Let us consider the dynamical mode of operation of the interferometer. Let us turn the interferometer (see Fig. 3) in the horizontal plane by 180° . Since the direction of light propagation is reversed with respect to the ether wind flow direction, the expression (16) will take the form

$$\Delta\varphi(t) \approx \frac{2\pi l_p}{\lambda} \left[W_h - w_p(t) \right] + \delta \tag{19}$$

In accordance with expression (10) and Fig. 2, the inequality $W_{ppf} h$ takes place on the time interval $t_0 \text{ } /d \text{ } ivie - h$. Consequently, the interferometer with a tube, in the dynamic mode of operation, is sensitive to the velocity difference of the external ether flow Oh of the ether flow inside the tube $ff p(t)$. Let us find the displacement of the interference pattern relative to its position in the established mode of operation of the interferometer. We will look for the displacement value in the form of the number of fringes of the interference pattern. For this purpose, we take the difference of expressions (19) and (18), divide both parts of the found expressions by $2p$, we obtain

$$\frac{\Delta\varphi(t) - \Delta\varphi(t)_{t \rightarrow \infty}}{2\kappa} = \frac{l_p}{2} \left[\frac{W_h - w_p(t)}{c} \right] \tag{20}$$

The left part of expression (20) is equal to the desired value of the interference pattern displacement, which is expressed by the number of periods of the light wave or the number of bands D , since the change of the phase difference by $2n$ corresponds to the apparent displacement of the interference pattern by one band. Consequently, Eq. (20) describes the change in time of the apparent displacement of the fringes of the interference pattern relative to their initial

position, $D(t)$, expressed by the number of fringes. Considering,

that the ether flow in the tube can have a direction opposite to the current shown in Fig. 3. 3, then expression (20) will take the form

$$D(t) = \pm \frac{l_p}{\lambda} \left[W_h - w_p(t) \right] \quad (21)$$

In expression (21), the sign "+" is applied when in the tube, in the dynamic mode of operation of the interferometer, the direction of light propagation coincides with the direction of the ether flow, and the sign "-" when these directions are opposite. According to expression (10) and Fig. 2, at the time instant '0, the velocity of the ether flow in the tube $w_d(t_0) = 0$. Then from (21) we obtain that at the moment of time t_0 the displacement of the fringes of the interference pattern takes the maximum value proportional to the velocity of the external ether flow W_z

$$D(t_0) = \pm \frac{l_p}{\lambda} \cdot \frac{W_h}{c} \quad , \quad (22)$$

and in the steady-state regime, when the velocity of the ether in the tube is equal to

$w_p(t) = W_z$, the displacement of the strips relative to their initial position is zero.

Let us show the time variation of the normalized value of the interference pattern fringe shift. For this purpose, let us use the expression (21) by (22) and, taking into account relation (17), we obtain

$$\frac{D(t)}{D(t_0)} = 1 - \frac{w_p(t)}{w_{pa}} \quad (23)$$

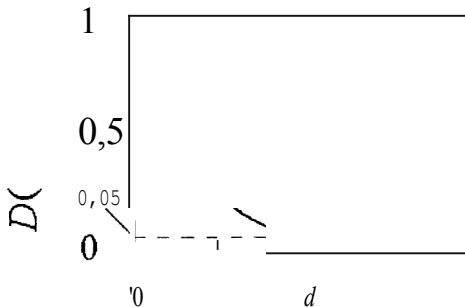

Fig. 4. Time variation of the fringe displacement of the interference pattern in the dynamic mode of operation of the tube interferometer

Fig. 2 shows that the ratio of $D(t)/D(t_0)$ varies in time within the range from 0 to 1. In this case, in the dynamic mode of operation of the interferometer, the time variation of the normalized value of the shift of the fringes of the interference pattern $D(t)/D(t_0)$ will have the form shown in Fig. 4.

4. Figure 4 illustrates the above conclusion.

In the dynamic mode of operation, an interferometer with a tube is sensitive to the velocity of the external ether flow Y_t , and with the help of such a device it is possible to show the presence or absence of optical anisotropy of space due to such motion.

From Fig. 4 and expression (22) it follows that if we measure the displacement of the fringes D relative to their initial position on the interferometer eyepiece scale at a time instant, we can find the value of the horizontal component of the ether wind velocity iF_t

$$O_h - + D(*_0) * \quad p' \quad (24)$$

In the measurement method **and the device** realizing it, it is not necessary to return the light beam to the starting point, as, for example, in the Michelson interferometer. In expression (22), the measured quantity D is proportional to the first degree of the **ratio of the** ether wind velocity (anisotropy magnitude) to the light velocity ($+h'$). Consequently, the proposed method and **apparatus** are the first-order method and **apparatus** for direct measurement of the ether wind velocity (anisotropy of the light velocity).

3. Kinematic viscosity of ether

According to expression (10), to calculate the parameters of the ether motion in the tubes, we need an idea of the value of the kinematic viscosity of the ether g . In turn, information on the ether motion in the tubes is necessary to calculate the design parameters of the measuring device and its metrological properties. We estimate the value of the value of g on the basis of the assumption made in [6] about the mechanism of photon formation as a result of the oscillation of the electron shell of an excited atom. Here, the vortex Karman track is proposed as a photon model, which allowed the author of [6] to explain the known optical phenomena and photon properties. Let us use this idea in TOJvt SMysle that the propagation of light is represented as the propagation of turbulent pulsations in the ether. In [28] it is shown that the existence of a stable turbulent pulsation motion in a liquid volume is possible if the Reynolds number is not lower than some critical value equal to

$$Re'' - w d v^{\sigma'}, \quad (25)$$

where w is the fluid velocity; d is the characteristic size of the streamlined body. In [28], the value of $Re_{Yu} 425$ was calculated. In relation to the problem to be solved, the values d , d , and w are, respectively, the atom diameter, the kinematic viscosity, and the aether velocity. From expression (25) we find

$$d - \text{and } d Re''' \quad (26)$$

The value of the kinematic viscosity of the ether obtained in this way is called its calculated value g . We **take the** velocity of displacement of the **electron** shells of atoms during the **emission** of a photon as the **velocity** of motion of the **ether** w . We will assume that this velocity is equal to the velocity of light $w - s$. The diameter of atoms, as we **know**, is $d -- i 0^{*1} \text{ } \circ m$ by order of **magnitude**. Then using expression (26) we obtain

$$v \quad 7 - 10^{*5} \text{ m's}^{*1} \quad (27)$$

The performed evaluation showed that the calculated value of the kinematic viscosity of the ether does not contradict the ideas of [6] about *the* ether as a gas-like medium with the properties of real gases. Thus, the values of kinematic viscosity of twelve gases common in nature are as follows: ranging from $7 \cdot 10^{-10}$ (carbon dioxide) to $1.06 \cdot 10^{-10}$ (helium).
M - C M - S

4. Optical interferometer

To realize the proposed measurement method, it is necessary to calculate the dimensions of the interferometer tube. The inner radius of the tube ar can be calculated in the following way. Divide both parts of expression (10) by wh and, taking into account that at time d (see Fig. 2), the ratio $lt'pp)t'is$ 0.95, we obtain the following value

$$1 - 8 \sum_{k=1}^{\infty} \psi_k^{-3} J_1'(y) \exp(-v \psi_k^2 a_p^{-2} t_d) = 0.95. \quad (28)$$

If we limit the accuracy of estimates to no worse than 7%, the series in the expression

(28) can be replaced by its first term. I substituted into expression (28) the numerical values of pt and $J_1'(fik)$ for reference: $r_1' 2.4048$; $J_1(p) = 0.5191$). In this case it is possible to obtain

$$ar' \quad 37 (d)'' \quad (29)$$

When calculating the tube radius $ar\#$ Jirgelnost of the dynamic mode of the interferometer operation td we will choose based on the time required to perform visual (or instrumental) readout of the fringe displacement value D . In expression (29), let $t_d -- \text{sec}$, and $g - v, 7 \cdot 10^{*5} \text{ } 11^2 \text{ G}^{*1}$. We **obtain** that for the construction of the interferometer it is necessary to use a tube with inner radius

$$ar \quad 0,01 \text{ m.}$$

The length of the tube Jp can be found using expression (24) in which under the values $D\{t)$ and $<h$ we will understand the values Dpq and $Wzpq$, respectively, where D is the minimum value of the stripes displacement

of the interference pattern, which can be counted with the help of the selected eyepiece and eyepiece: $+h$ is the minimum value of the velocity of the ether wind (the magnitude of the anisotropy of the speed of light), which needs to be measured by the interferometer (the sensitivity of the interferometer). In this case it is possible to obtain

$$l_p \approx D_{\min} \lambda c W_{h \min}^{-1} \quad (30)$$

If put in expression (30) the values $D_j - 0.05$, $f_i - 20\text{m/sec}$ и $\lambda - 6.5 \cdot 10^{-7}\text{m}$ (light source light c wavelength = $6.5 \cdot 10^{-7}\text{m}$), then the required pipe length is $l_p - 0.49\text{m}$.

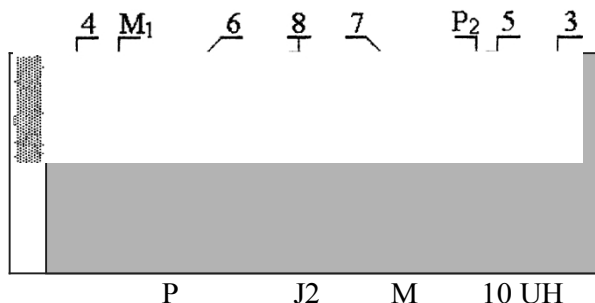

Fig.5. Interferometer design

The schematic drawing of the prepared interferometer is shown in Fig. 5 (top view). The designations of the main nodes adopted in Fig. 3 are retained here. 3. In addition, the following are shown: 4,5 - nodes for adjusting the interferometer; 6,7 - stands for fixing translucent plates and mirrors; 8 - interferometer frame; 9 - illuminator power supply; 10 - illuminator switch; 11 - eyepiece fixing assembly; 12 - heat-shielded casing; 13 - removable casing wall on the eyepiece side. The frame 8 is made of steel profile with a reverse cross-section. The thickness of the profile walls is 0.007 m. The height of the profile is 0.02 m. The length of the frame is 0.7 m, width 0.1 m. The interferometer nodes are fixed on the flat surface of the frame. Stands 6 and 7 are made of rectangular copper tubes with an inner section of 0.01 m x 0.023 m. The light rays pass inside these tubes. The distance between the beams RIM, and M,P2 is 0,12 m. On the posts, at the points P, Semitransparent plates were installed in the Pt points and mirrors in the Me and Me points. In the prepared interferometer, plane-parallel glasses 0.007 m thick were used as translucent plates. The glasses and mirrors are held on racks 6 and 7 by springs. Glasses, mirrors and their fastening units are not shown in Fig. 5 is not shown conventionally. Nodes 4 and 5 allow to change the position of posts 6 and 7 in two mutually

perpendicular planes. Pipe 2 is steel with an inner radius $ar - 0.0105$ m. The length of pipe 1 is 0,48 m. Pipe fastening nodes are not shown conventionally. As

A semiconductor laser with a wavelength $\lambda = 6.5 \cdot 10^{-7} \text{ m}$ is used in the illuminator. The optic voltages are parallel to the plane of the frame. The interferometer was covered with a heat-shielding casing 12 and was placed on a rotating slide table made of dielectric material 0.02 m thick. The rotation was ensured by means of a thrust ball bearing, which is located between the slide table and the support. The support is equipped with devices for setting the interferometer in the potted position. The casing 12 is made of rigid foam heat-insulating material and in cross-section is a rectangular tube with internal dimensions: width b , - 0.22 m, height h , - 0.11 m, length $l = 0.8 \text{ m}$. The thickness of the walls of the boiler is 0.06 m. The wall 13 is made of soft heat-insulating material. The eyepiece with a scale 3 allows measuring the minimum displacement of the interference fringes of the interference pattern with the value $D = 0.05$. At the initial stage of research, in the work [30] mentioned in the preface, the thermal-isolating casing of the interferometer was made of soft thermal-isolating material reinforced on a cardboard frame. Later, the shell, the construction of which is described in this paper, was made. Both housings have the same internal dimensions. The change in the design of the casing did not introduce any noticeable changes in the metrological properties of the device.

Let us note the peculiarities of operation of the fabricated interferometer. In contrast to the scheme shown in Fig. 3, the real design contains a casing 12, which can significantly affect the operation of the interferometer. Let us consider the motion of ether through the material of the casing 12 as the motion of gas through a porous medium, which allows us to apply the provisions of the filtration theory [41]. Let in Fig. 5, from right to left, is α flow of ether. Three parts are conventionally distinguished in the flow. The first part moves outside the casing 12, the second part moves inside the side walls of the casing, and the third part passes both end walls of the casing and moves in the inner cavity of the casing. It is known that the filtration velocity W is determined by Darcy's law $W = -k/h L \cdot \rho$, where k is an empirical coefficient of filtration; h is the pressure lost at the length of the filtration path L . According to Darcy's law, the flow velocity at filtration is inversely proportional to the length of the filtration path. It can be seen that the second part of the ether flow, moving inside the side walls of the casing, has the lowest velocity of the three parts of the ether flow, since it has the longest length of the filtration path L equal to the length of the casing. According to the Beriuilli equation, the pressure is highest in the part of the gas flow moving at a lower velocity [27,28]. Consequently, in the part of the ether flow moving in the thickness of the side walls of the casing, the pressure is higher than in the adjacent parts of the flow. This part of the flow with higher internal pressure plays the role of the tube wall, which, with respect to the casing of the interferometer, divides the ether flow into external and internal flows. Hence, the conclusion follows,

important for further analysis of the performance of the fabricated interferometer - The protective casing of the interferometer, made of porous dielectric heat-insulating material, acts as a guiding system with respect to the ether flow. (The results of the experimental verification of this assumption are given in the section "Testing of the interferometer.") In this case, the ether flow external to the tube 2 should be considered to be the ether motion in the inner cavity of the casing 12, in which, as in the tube 2, the ether motion will develop starting from the moment. In this case, expression (21) takes the form

$$D(t) = \pm l_p \lambda^{-1} c^{-1} [W_c(t) - w_p(t)], \quad (31)$$

where $W(t)$ is the time variation of the velocity of motion of the ether in the coil of the interferometer. This circumstance requires solving the problem of the motion of the ether resting in a rectangular tube. To solve the problem, we will use the technique, widespread in hydrodynamics, of comparing the fluid motion in a pipe of a complex profile with the fluid motion in an "equivalent" pipe of circular cross-section, in which the so-called "hydraulic" radius ah , equal to the ratio of the area of the normal section of a pipe of a complex profile Gp to the perimeter of the cross-section of this pipe Np [7], is taken as the radius.

$$a_h = Gp / Np \quad (7)$$

This allows us to use the mathematical apparatus developed in the analysis of flows in circular tubes. In this case, the value of $W(t)$ can be calculated using an expression similar to expression (10), in which the "hydraulics" radius of a rectangular pipe ah is used as the radius of a circular pipe ar *deme use*

$$W_c(t) \approx w_{pac} \left[1 - 8 \sum_{k=1}^{\infty} y_k^{-3} J_1^{-1}(\psi_k) \exp(-\nu \psi_k^2 ah^{-2} t) \right], \quad (33)$$

where w_{pac} is the velocity of the steady motion of the ether in the casing of the interferometer. In this case, as before, we will assume that the value of w does not differ appreciably from the velocity of the wind flow of the ether fly and we can write down

$$W_c(t)_{t \rightarrow \infty} = w_{pac} \approx W_h. \quad (34)$$

Let us calculate the value of the hydraulic radius of the casing ah The dimensions of the casing are given in the description of the interferometer. Calculating the values of Gp and Np using expression (32), we obtain $ah = 0.0367$ m.

It can be seen from expression (29) that the duration of the dynamic mode of operation of the interferometer d will be determined by the tube of larger radius. Since $ah > ar$, the value of td in the manufactured interferometer will be determined by the value of the "hydraulic" radius

casing az

$$t_d = 0.53 \cdot a h \nu^{\circ} \cdot l \quad (35)$$

Let us find an expression for calculating the time variation of the interference pattern fringe shift $D(t)$. Substituting into expression (31) the expressions (10) and (33) for the values of $Wp(f)$ and $\Pi_{\nu}(l)$ respectively, and taking into account relations (17) and (34), we obtain the following results

$$D(t) = \frac{1}{8} p_h \lambda^{-1} c^{-1} \sum_{k=1}^{\infty} \psi_k^{-3} J_1^{-1}(\psi_k) \times \\ \times [\exp(-chka^2 t) - \exp(-gu'^2 ah^2 t)]. \quad (hs)$$

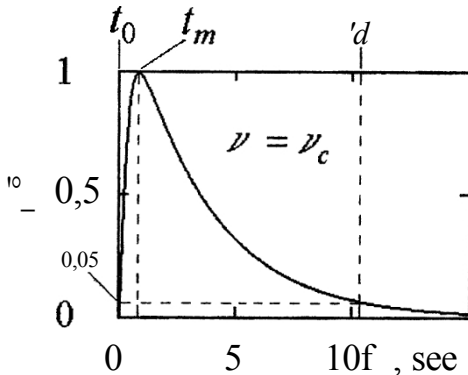

Figure 6. Variation of interference fringe shift in time

Fig. 6 shows in normalized form the result of the calculation of the dependence $D(t)$ performed with the help of expression (36). The number of members of the series $k - 4$, the calculated value of the kinematic viscosity of ether $\nu = 7 \cdot 10^5 \text{ m}^2 \text{ s}^{-1}$, and the following values of the constructive parameters of the interferometer: $ar - 0.90105 \text{ m}$; $az - 0.0367 \text{ m}$; $fp - 0.48 \text{ m}$; $2 = 6.5 \cdot 10^7 \text{ m}$ were used in the calculation. In Fig. 6 shows that after the time $t = 0.82 \text{ sec}$, which is counted from the moment t_0 - the time of the dynamic mode of operation of the interferometer, one can expect the observation of the maximum value of the interference pattern fringe shift $D(t_m)$. The live duration of the dynamic mode of interferometer operation

$t_d - 10.3 \text{ sec}$. The values $D(t_m)$ and t_d in the present measurement method are measurable. Fig. 6 shows that a one-time measurement of the interference pattern fringe displacement value $D(t_m)$ requires the time t_d - p. Correspondingly, for a one-time measurement of the duration of the dynamic mode of operation of the interferometer t_d the time t_d is required. Relatively small values of the duration of one-time measurements of $D(t_m)$ and t_d significantly simplify the requirements to the parameters of thermal protection of the interferometer. According to Fig. 6.

should be such that when measuring the value $D(tp)$, the temperature drift velocity of the interference pattern fringes $K/$, does not exceed the value $CD - D' tSD' "$ $D < 0.06$ fringes/sec, and when measuring duration of the dynamic mode of the interferometer *td the value of* V_D Must not exceed the value $V_D - Dj./tz$ or $D < 0.0048$ band/sec.

5. Interferometer test

The tests included statistical and dynamic tests of the rigidity of the fabricated interferometer structure and the stability of the interferometer to thermal effects. At the final stage of the tests, the kinematic viscosity of ether was measured, which allowed us to experimentally refine the metrological properties of the interferometer.

The rigidity of the interferometer was tested in two ways. In the first method, the interferometer was stopped on a hard horizontal surface. One of the edges of the frame was raised so that the angle of inclination of the frame plane to the surface plane reached 20° . In this frame position, the sweep of the interference pattern hair due to elastic deformations of the interferometer did not exceed 0.3 fringes ($\{D y 0.3$). According to the second method, the stiffness of the interferometer was checked in the assembled form, in the working position. Angles of inclination of the interferometer up to 10° were created by tilting the slide table. No noticeable displacement of the fringes was observed. Consequently, within the specified limits, the fabricated interferometer is not sensitive to errors in its horizontal positioning.

The stability of the interferometer to shock loads was checked. Light blows on the interferometer frame, slide table, and support caused the interference pattern fringes to shake for a fraction of a second. The interference pattern was not destroyed. After the shock loads were stopped, the fringes retained their initial position.

Tests of the interferometer on the terrain selected for experimental studies showed the following. The movement of pedestrians and cars within 20 meters from the interferometer installation site and the movement of an observer in the immediate vicinity of the interferometer installation site did not cause any noticeable displacement or shaking of the fringes. In windy weather, at wind speeds up to 6 m/sec, the interference pattern is stable. Consequently, the area selected for the location of the measuring station is suitable for systematic measurements in the optical wavelength range.

Thermal tests of the interferometer were carried out in the thermal yc-

The interferometer was set to different azimuthal orientations. Different azimuth orientations of the interferometer were set. In a stationary position, the interferometer was heated by solar radiation. During a time period of 30 minutes, the fringe shift did not exceed the value of $D - 0.35 D - 0.0002$ fringes/sec). Consequently, the design of the interferometer and the quality of its thermal protection are such that they allow one-time measurements to be performed in full-scale conditions, with the duration of the measurement procedure up to 250 sec, which naturally exceeds the required calculated duration of the one-time measurement procedure (= 15 sec).

The principle of the measurement method allowed us to perform dynamic tests of the stiffness of the interferometer structure in the working position. The test procedures did not differ from those of the accepted measurement methodology. The essence of the tests is as follows. Let each of the light rays in the interferometer pass along the axes of tubes with equal geometric dimensions. Then, in the dynamical mode of operation of the interferometer, the processes of establishing the ether motion in each of these tubes are identical. In this case, according to expression (36), the value of the displacement of the interference pattern fringes $D(t)$ should be equal to zero, and this should be fulfilled with sufficient rigidity of the structure. The tests were carried out in natural conditions in different seasons of the year and at different times of the day. Pipes of equal geometric dimensions made of both homogeneous and different materials (metal, transparent dielectric, glass) were used. In all cases, after rotation of the interferometer, no noticeable displacement of the interference bands was observed. With the exception of attempts to apply a sharp, nonspecific cessation of rotation of the interferometer in order to observe the effects of elastic deformation of the interferometer structure. In such attempts, the fringes were displaced with a velocity D of 0.2 for a fraction of a second, after which the fringes occupied the initial position. The results of the dynamic tests showed that the stiffness of the fabricated interferometer was sufficient to perform the procedures stipulated by the measurement methodology. An important result of this stage of testing was the experimental confirmation of the notion that dielectric tubes can be the same **guiding** systems for ether flows as metal tubes.

Dynamic tests of the interferometer with two tubes of equal size allowed us to remove the assumption about the possible influence of internal temperature effects on the measurement results. Thus, it can be assumed that under real-world conditions, individual components of the device may have different temperatures. As a consequence, during dynamic operation, the air flows inside the heat-insulating casing in different parts of the device can acquire different temperatures, which can-

can lead to measurement errors. The test results showed that, if this assumption is true, its influence is small and lies beyond the sensitivity threshold of the prepared interferometer.

Dynamic tests of the interferometer confirmed the known result that the reduction of homogeneous air flow in the interferometer's optical bundles does not lead to noticeable variations in the measurements [15]. Nevertheless, the maximum value of such an oyuibka was estimated. It was assumed that air with refractive index $p = 1.0004$ moves at a velocity of $K - 10$ m/sec in only one tube of the interferometer (the value of G was taken to be much larger than expected). Taking into account the Fresnel entrainment coefficient $k - v^2$, it can be obtained that the displacement of the fringes of the interference map caused by such air motion does not exceed the value $D 3.5 \cdot 10^6$, which is 14000 times smaller than the minimum possible observed value $D - 0.05$.

The final stage of the tests was an adjustment series of measurements performed to clarify the metrological properties of the prepared interferometer. It was determined experimentally that after the end of the dynamic mode of operation of the interferometer, no appreciable displacement of the fringes of the interference pattern relative to their actual position was observed, i.e., the magnitude of the fringe displacement $D(t) \rightarrow 0$. This result does not contradict the assumptions (17) and (34) about the small resistance of the tubes of the interferometer to the motion of the ether outside these tubes. In this case, it can be assumed that

$$v(t) = wh \tag{37}$$

In other words, expression (37) shows that in the established mode of operation of the interferometer (at r -ru) the velocities of ether motion in the tubes $w_p(t)$ and $W_d(t)$ differed so little from each other and from the velocity of the external flow h that the value of D was beyond the sensitivity of the interferometer. This experimental result was used in the derivation of relation (18). The results of the final stage of the interferometer tests showed that the measured dependences $D_d(t)$ do not contradict the initial theoretical ideas about the effect of the measurement method, which are shown in Fig. 6. 6. Thus, the measured value of the r_p veltina was i sec; the measured values of the duration of the dynamic mode of the interferometer operation were within the range of $id - 10 \dots 13$ sec. The ambiguity of the measured values of the value t_d is caused, first of all, by the difficulties of visual counting of small values of the slowly changing value D at the end of the dynamic mode, i.e., at $t \rightarrow iz$.

The test results showed that the manufactured interferometer is resistant to mechanical and thermal influences within the framework of the adopted methodology of systematic measurements.

6. Measurement of kinematic viscosity ether

It follows from expression (35) that, having the measured knowledge of the value of rg , it is possible to determine the value of the kinematic viscosity of ether

$$g - 0.53^2 td_h \quad (38)$$

The value of kinematic viscosity determined in this way will be called the measured value of kinematic viscosity g . Substituting into expression (38) the value of ah -- 0.0367 m and the value of d -- (10...13) sec measured during the interferometer tests, we obtain the following value

$$v_e \quad (5.5... 7.1) 10^{*5} \text{ M}^2\text{C}^{-1} \quad (39)$$

The average **value of kinematic viscosity v , calculated** as the average value of the function $v - f(td)$ over the interval (10... 13) sec is equal to

$$v_{ea} = 6,24 \cdot 10^{-5} \text{ MG}^{2-1} \quad (40)$$

Comparing the results (27) and (40), it can be noted that the calculated and measured values of the kinematic viscosity of ether coincide g , - g'' . The possibility of retrieving the ether viscosity measurement is of certain interest, since up to the present time there is no information in the literature about the ether viscosity in free space, methods and means of its measurement.

7. Metrological properties of the interferometer The measured

value of the kinematic viscosity of ether ea And re-

The results of the tests make it possible to specify the metrological properties of the prepared interferometer. I substituted the measured value of $r'' = 6.24 \cdot 10^0 \text{ mas}^0$ into expression (36). I found that the values of p - 0.93 sec and tz 11.5 sec calculated in this way practically coincide with their measured values / p - 1 sec and tz 11.5 sec.

d -- 10... 13 sec. Consequently, the results of the interferometer tests do not contradict the ideas about the effect of the proposed measurement method and the results of the metrological properties of the interferometer presented in Fig. 6. 6.

To determine the velocity of the external ether flow (the magnitude of anisotropy) Oh , we can use the measured value of the displacement of the interference pattern at time iq , when $D\{tg\}$ -- max. From expression (36) we obtain

$$W_h \approx D(t_m) \lambda c \left\{ 8l_p \sum_{k=1}^{\infty} \psi_k^{-3} J_1^{-1}(\psi_k) \times \right. \\ \left. \times [\exp(-v y a \{^2 fp\}) - \exp(-g y,^2 a^{-2} t_m)] \right\}^{-1}. \quad (41)$$

I substituted into expression (41) the measured values of the velocities $v = 6.24 \cdot 10^5 \text{ m}^2 \text{ s}^{-1}$ and $g = 1 \text{ sec}$, the values of the design parameters of the prepared interferometer and the calculation parameter (the number of interferometers of series k): $ar = 0.30105 \text{ m}$; $ah = 0.0367 \text{ m}$; $dr = 0.48 \text{ m}$; $2 = 6.5 \cdot 10^7 \text{ m}$; $k = 4$. In this case, the expression (41) will be as follows

$$W_h = 525 D(t_m) \quad (42)$$

Let us calculate the sensitivity of the fabricated interferometer to the velocity of the ether wind (anisotropy of the speed of light), i.e., determine the minimum value of Wt , which can be measured. It is noted in the section "optical and differential interferometer" that the minimum value of the magnitude Dj that can be measured using the selected ocular and Dj scale is 0.05. Then, using expression (42), we obtain $Wz = 26.25 \text{ m/sec}$.

Let us determine the aether flow in the tubes of the fabricated interferometer $Wz = 26.25 \text{ m/sec}$. For this purpose, using the expression (4) we substitute the minimum value of Reynolds number for the Pipe with radius $ad = 0.0105 \text{ m}$. Poluchin $Re = 8838$. According to the condition (3) it can be written that $Re > Re_{crit}$. Hence, only turbulent aether flow is possible in the tubes of the interferometer.

8. Methodology measurements

The measuring point is located in 13 km from the northern outskirts of Kharkiv. To observe the "height effect" at the measuring point two positions were equipped. At position No. 1 the interferometer was installed at a height of 1.6 m above the ground. At position No. 2 at a height of 4.75 m. The measurements were carried out cyclically. The duration of one cycle was 25-26 hours. During one month 2-4 cycles were performed. Each cycle contained the following procedures. The interferometer was placed in position so that the plane of its rotation was horizontal. After installation, the interferometer was kept in the new temperature conditions for one hour (the instrument was stored indoors). One-time readout of the measured values was performed according to the following scheme. The longitudinal axis of the interferometer was set along the meridian, so that the illuminator 1 was facing north. In this initial position, during the interferometer's steady-state operation, the dial registered the initial position of the fringes of the interference pattern relative to the local ocu-

This is the initial position of the bars. This initial position of the fringes was assigned a value of $D = 0$. Then the observer changed his position - took a place at the illuminator. The interferometer was rotated by 180° . The rotation was performed in a time of about three seconds. During the rotation, the ether motion in the tubes was interrupted. The interferometer entered the dynamic mode of operation, hO-toryil is described by expression (36). In the dynamic mode of operation of the interferometer, the observer recorded the maximum value of the fringe displacement $D(tp)$ and the time of return of the fringes d'' to the initial position. After the time d' had elapsed, the interferometer entered the steady-state mode of operation and rotated to the initial position. During the time of one measurement (up to 10 minutes), 5-7 single counts of the measured values were made. The average value of counts was taken as the measured value of $D(t)$ and d' where d is the average measurement time.

9. Processing the results of measurements

The measurement results are presented in the form of tables of $D_i(t)$ values. These data were used to calculate the values of the ether wind velocity V . The calculations were performed using expression (42). Further processing included the standard procedures used for processing the results of the expert [31]. The following were calculated: the variation of the ether wind speed during individual days; the average variation of the ether wind speed during the epoch of the year and throughout the entire series of measurements; the standard deviation of the ether wind speed from the mean value w_p ; and the correlation coefficients g between the results of different experiments. The confidence estimates of the mean values were calculated with a reliability of 0.95.

10. Measurement results

In this paper, we discuss the experimental results obtained in a series of measurements **carried out** from August 2001 to January 2002. (The results of this series of experiments were first published in [30].) The measurements were carried out using the first-order optical measurement method described above. During the series, 2322 counts of the measured velocity were made. The distribution of the number of readings by months of the year is shown in Table 1.

Table 1

Distribution of counts by month of the **year by month of the year**

Month (era) of the year	August 2001 г.	September 2001 г.	October 2001 г.	November 2001 г.	December 2001.	January 2002 г.
Quantity-counts	792	462	288	312	240	228

In accordance with the objectives of the study, the results of the present work were considered in parallel with the results of the experts [1-3], [7-9, 21], and [10]. These four experiments were carried out in different locations on the globe using three different measurement methods and in different ranges of electromagnetic waves. Experiments [1 -3] (Ukraine, 1998-1999 rr.) were performed in the range of milliwave radio waves using the first-order measurement method. Experiments [7-9, 21] (USA, 1921-1926) and [10] (USA, 1929) were carried out using second-order optical measurement methods using cross-shaped interferometers prepared according to the Michelson scheme. The action of the measurement methods used in the above-mentioned experiments is based on the ideas about the propagation of electromagnetic waves in the moving ether, the medium responsible for the propagation of these waves, which makes it possible, within the framework of the initial hypothesis, to interpret the results of the above-mentioned experiments in terms of the ether wind velocity. Let us consider the manifestation of the desired effects of the ether wind: anisotropy, height, space, and hydrodynamic effects in experiments on the propagation of electromagnetic waves. The fragments of Fig. 7 shows the average results of the present work (Fig. 7a), experiment [1-3] (Fig. 7b), and experiment [7-9, 21] (Fig. 7c), which were obtained in different years during the August epoch. The results of the experiment [10] are not presented because the authors limited themselves to the maximum value of the measured anisotropy $+h \approx 6000$ m/sec . The ordinate axes show the values of the ether wind velocity (anisotropy magnitude) iF in m/sec, and the abscissa axes show the solar time of day Tp in hours. Vertical lines indicate confidence intervals. Each of the fragments of Fig. 7 illustrates the manifestation of the desired anisotropy effect.

In the present work and in the experiments [7-9, 21], [10], the anizotroishi effect was detected by rotating optical interferometers, while in the experiment [1-3], simultaneous counter propagation of radio waves was used.

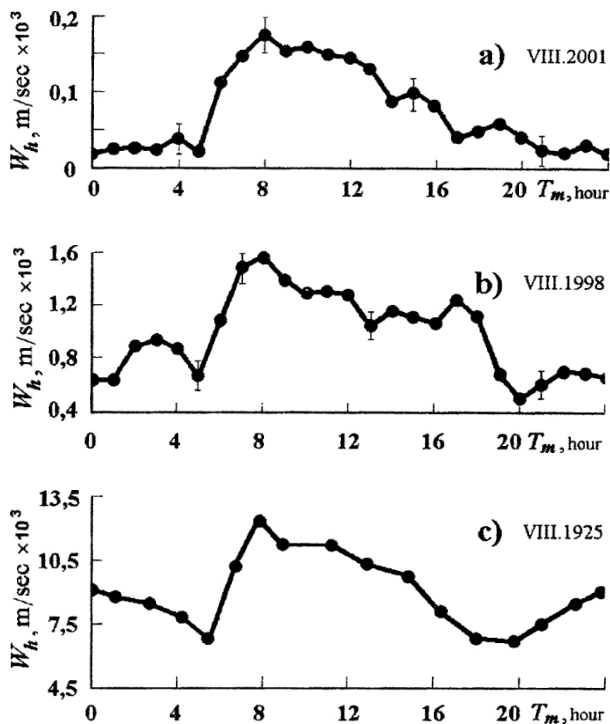

Fig. 7. Variation of the ether wind speed during suyuk in the epoch of August from the data of different experiments (a) present work, (b) experiment [1-3], (c) experiment [9]

The results of all three experiments showed that the velocity of the ether wind changes during the day, and such changes are of a similar nature. Thus, the correlation coefficients g found between the $W_z\{T_p\}$ dependences lie within the range $0.73 \leq g < 0.85$. In [7-9, 21], the change in the ether wind speed during the day was explained by the motion of the solar system toward an apex with coordinates close to the coordinates of the north pole of the ecliptic. In this case, the projection of the velocity vector of the relative motion on the horizontal plane of the device and, consequently, the velocity of the etheric wind Oh will vary during the day. This explanation does not contradict the results of the present work and can be taken as the initial one.

According to the initial hypothesis, the horizontal component of the ether wind velocity Oh should change its value with a period of one stellar day (cosmic effect). In order to detect-

to live the variation of the ether wind velocity with such a period, the results of systematic measurements were subjected to statistical processing on the stellar time scale. The results of such processing are shown in Fig. 8. In the fragments of Fig. 8, the stellar time S in hours is plotted along the abscissa axes, and the values of the ether wind velocity $+h - m/sec$ are plotted along the ordinate axes. The vertical dashes indicate confidence intervals. Fig. 8a shows the average daily variations of the ether wind velocity during the of stellar days $\ddot{I}G(S)$. This dependence is calculated from the results of the measurement-

During the five months of the year, from September 2001 to January 2002, the numerical value of sidereal time shifts relative to solar time by 10 hours.

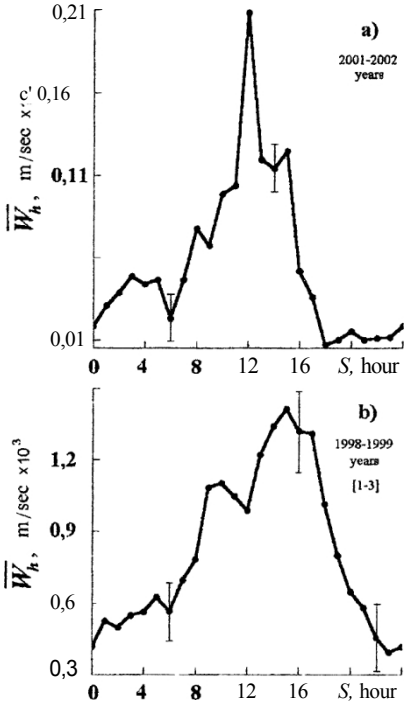

Figure 8. Mean diurnal variations of the ether wind speed

For comparison, Fig. 8b shows the average result that was obtained in the experiment [1-3] over the five months of the year with the same name, from September 1998 to January 1999. (In the present work, Fig. 8b, in contrast to a similar figure in [1-3],

the measured velocity is expressed in values of the ether wind velocity). Both **fragments of Fig. 8** have in general a similar character of ether wind velocity variation during the day. The differences in the shapes of the curves can be explained within the framework of the concept of the interaction of the viscous ether flow with the terrain elements (which had different characteristics in these different experiments) and the peculiarities of the location of the radio line on the terrain in the experiment [1-3].

In the fragment of Fig. 8a (present work), compared to the result of the experiment [1-3] (Fig. 8b), the velocities of the ether wind have smaller values, which is explained by the difference in the heights of the measuring points in the of these experiments. The $w_h (S)$ dependences have the form of periodically changing values with periods equal to stellar days, which can be explained by the cosmic (galactic) origin of the aether wind.

The results obtained in the present work and in experiments [1-3], [7-9], [10] illustrate the manifestation of another effect of the ether wind that is sought, the height effect. It can be seen that the velocities of the ether wind measured in **each of the** presented experiments at different heights from the Earth's surface differ. Table 2 shows the average values of the maximum velocities of the aether wind measured in the present work and in experiments [1-3], [7-9], [10]. In these four experiments, measurements were made at five different heights: 1.6 m and 4.75 m in the present work; 42 m in experiment [1-3]; 265 m and 1830 m in experiment [7-9] (Cleveland and Mount Wilson Observatory respectively). In the experiment [10], measurements were also carried out on the of the Mount Wilson Observatory. However, unlike the experiment [7-9], which was carried out in a light wooden house, the **experiment 10 was carried out** in the fundamental building of the optical workshop of the observatory.

Table 2

Results of measurements of the ether wind speed at different locations heights above the earth's surface

Height above *(meters)	Ethereic wind speed (m/sec)			
	The present work 2001-2002 rr. Optics	KC^eri Agent[1-3] 1998-1999 rr. Диапазон radio waves	Experi-ments[7-9] 1925-1926 rr. Optics	Experime nt [10] 1929 г. Optics
1830			10000	6000
265			3000	
42		1414		
4,75	435			
1,6	205			

It can be assumed that the inhibition of the ether flow by the walls of the building was the reason for the smaller value of the ether wind velocity measured in the experiment [10] compared to the result of the expert study [7-9]. In the present work, an attempt is made to verify this assumption. The verification was performed in the upper floor room of a 14-story brick building. The measurements gave anisotropy values 3-4 times smaller than in the open area, which does not contradict the assumption about the inhibition of the ether wind by the walls of the building. Figure 9 shows the dependence of the ether wind velocity on the height above the Earth's surface. The values of the logarithms of the values $\langle h' \rangle$ and $Z' Z'$ are plotted along the abscissa and ordinate axes. The values of V and Z are plotted on the axes of abscissa and ordinate.

v_0 are equal to 1 m/sec and 1 m, respectively. For clarity, in the upper and in The values of V in m/sec and Z in meters, respectively, are plotted on the right side of Fig. 9 along the coordinate axes. The figure shows the results of the present work and experiments [1-3], [7-9], and [10]. Fig. 9 shows that the results of different experts obey the same law and are arranged in a straight line. In the height range from 1.6 m to 1830 m, the ether wind speed increases with increasing height above the Earth's surface within the range from 200 m/s to 10000 m/s, which illustrates the manifestation of the desired effect of altitude.

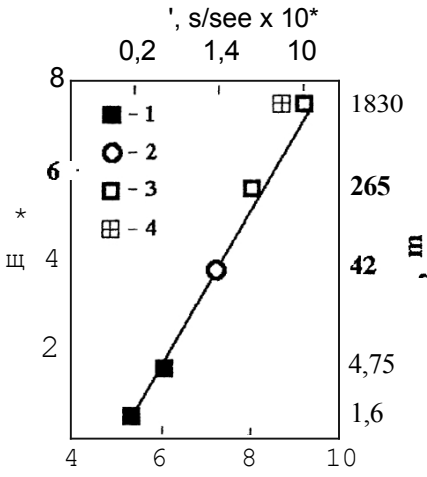

Fig. 9. Dependence of the wind speed on the height above the Earth's surface 1 - present work; 2 - experiment (1-3); 3 - experiment [7-9]; 4 - experiment [10]

These data do not contradict the **ideas of the model** (4-6) about the viscous

ether and the known regularities of viscous media flow **in the BHPIIZP HO-**

of the interface [27,28]. In the present work, the kinematic viscosity of ether was calculated and measured. The calculated value of the kinematic viscosity of ether $\nu = 7.06 \cdot 10^{15} \text{ m}^2 \cdot \text{s}^{-1}$ coincides with the order of magnitude with the average of the measurement results $\nu = 2.4 \cdot 10^{15} \text{ m}^2 \cdot \text{s}^{-1}$ (The procedures for calculating and measuring kinematic viscosity are described above).

The existence of the required hydrodynamic effect is shown by the following. The theory of viscous media flows in pipes developed in [27,28] was used in this work. This allowed, within the framework of the initial hypothesis, to present: a method and a first-order device for direct measurement of the ether wind velocity; a method and a device for measuring the kinematic viscosity of the ether; a method for calculating the design parameters of the measuring device and its metrological properties. The test results of the manufactured device do not contradict the results of calculations. The measurement results obtained at different heights from the earth's surface do not contradict the laws of viscous media flow near the interface known in hydrodynamics [27,28]. Consequently, the idea of the measurement method, the results of tests of the measuring device, and the results of experimental studies give reason to believe that the manifestation of the hydrodynamic effect is experimentally demonstrated. The results of the experiments presented in Figures 7, 8, 9 show the observability of the ether wind effects, the repeatability of the phenomenon properties in different observational conditions, the reproducibility of the phenomenon properties when using different experimental methods and different ranges of electromagnetic waves. The high values of correlation coefficients between the results of different experiments give grounds to positively assess their merit. fidelity.

The results of the present work make it possible to show that the negative results of the experiments [12, 14] can be explained by the insufficient sensitivity of the interferometers used in [12, 14]. Figures 7, 8, and 9 show that, directly near the Earth's surface, the magnitude of the light velocity anisotropy (within the framework of the initial hypothesis, the velocity of the ether wind) does not exceed 200 m/sec. Consequently, in the experiments [12,14] performed in basement rooms, the sensitivity of interferometers $\Delta \nu / \nu$ to the magnitude of anisotropy should be no worse than 200 m/sec. Let us calculate the sensitivity of the interferometers used in the experiments [12,14]. We will assume that the shift of the interference fringes $\Delta \nu / \nu = 0.04$ corresponds to the value of $\Delta \nu / \nu$. Such a shift of the fringes was expected to be observed in experiment [14]. From expression (1), we find

$$\Delta \nu / \nu = c(Dp, f^0)^{-2} . \quad (43)$$

In experiments [12], [14], the length of the beams l were 2.4 m and 22 m, lengths

waves $d = 6 \cdot 10^7$ m. Using expression (43), we obtain that in the experiment [12] $iGr = 30000$ m/sec, and in experiment [14] $W = 10000$ W sec. Consequently, the sensitivity of interferometers in experiments [12] and [14] was insufficient. The result of this evaluation can be shown more clearly by calculating the lengths of light rays l required for the construction of a cross-shaped Michelson interferometer with sensitivity to the ether wind velocity $W = 200$ m/sec. From expression (1) we find

$$l = DC^3 W^{\circ} \quad (44)$$

Substituting into expression (44) the values of $D = 0.04$, $y = 6 \cdot 10^7$ m; and $iF = 200$ m/sec. We obtained $l = 54000$ m. It can be assumed that the task of producing a cross-shaped optical interferometer with ray lengths of $l = 54000$ m is most likely technically unrealistic. Consequently, in the experiments [12] and [14], the anisotropy of the speed of light could not be detected due to a single instrumental reason: the experts used second-order interferometers with insufficient sensitivity. It is appropriate to emphasize once again the advantage of the first-order measurement method proposed in this paper. It can be calculated that near the Earth's surface, at the great anisotropy of the light velocity = 200 m/s and other conditions being equal, the first-order method is one and a half million times more sensitive than the second-order Michelson interferometer method. This circumstance complicates the applicability of the Michelson interferometer for detecting the ether wind near the Earth's surface.

This assessment is also valid for such experiments as [17--20]. In addition, the above-mentioned results of the interferometer tests with tubes made of different materials, the calculated and measured values of the kinematic viscosity of ether, suggest that the properties of ether flows are close to the properties of the flows of Swedish gases, enveloping obstacles and flowing in the guiding systems. In the experiments [17--20], this circumstance could be the reason for unsuccessful attempts to detect the ether wind (to reveal the anisotropic properties of space) using devices enclosed in hermetic metal chambers.

The results of the present work make it possible to explain the results of modern experimental attempts to detect anisotropic properties of space, e.g., [32--35]. In [32], an optical measuring device was used, the scheme and operation of which are not fundamentally different from the device used by M. Geck (1868) [36]. In both cases, the authors expected to observe a sweeping of the interference fringes proportional to the degree of the ratio of the anisotropy magnitude to the speed of light. The experiments [32] and [36] gave a negative result.

The optical anisotropy of space was not observed. Heck's error has been repeatedly addressed, for example, in [15], where it is exhaustively shown that taking into account the 'Orenel entrainment coefficient leads to compensation for the first-order effect, which could be caused by the Earth's motion and which was expected to be observed in the experiment [36]. The conclusion of [15] is also fully applicable to [32]. In another case, in experiments such as [33-35], the results of experiments [17-20, 37], in which the measuring devices are completely enclosed in metal screens, are repeated, as a consequence, the results of experiments [33-35] are identical to those of experiments [17-20, 37] - the desired magnitude of anisotropy was not observed. The inapplicability of massive screens in such experiments was first noted in [14, 21]. It should be added that the authors of the experiments [33-35], to all appearances, have developed reliable methods for discriminating physical processes occurring inside the experimental setup from processes in the surrounding space. However, it is not possible to study the properties of the surrounding space with the help of measuring devices separate from this space. It can be suggested that the reason for the instrumental limitations of the works [32-35] is common and lies in the following. When setting up the experiments, the authors gave up attempts to consider possible physical reasons for the space anisotropy they were looking for. Otherwise, the instrumental and methodical methods of their search *would have been* different.

In conclusion, we note the following. In this paper, the enterprise-
An attempt was made to interpret the results of the study within the framework of the working hypothesis of a viscous gas-like ether [6]. In [7-9, 21], the results of the experiment are explained as the result of the relative motion of the observer and the ether, the medium responsible for the propagation of electromagnetic waves. In the experiment [1-3], the model of a viscous gas-like aether proposed in [6] was used for the same purpose. It can be seen that the results of the present work and experiments [7-9, 21] and [1-3] do not contradict the main provisions of both the hypothesis of a viscous gas-like ether and the hypothesis of a viscous physical vacuum, if we assume that the vacuum, due to the interaction of virtual particles, possesses viscosity. At first sight, this assumption gives a reason to consider these hypotheses equivalent. Nevertheless, the hypotheses are concerned. Indeed, the representation of the quantum field theory about virtual particles of the vacuum requires the introduction of an additional assumption about the presence in the vacuum of a "building" material of particles, which is not provided by the existing vacuum theory. There is no answer to a number of questions, **for example, what is** the virtualRoe state of particles at which they, having arisen, immediately annihilate? What is "i m m e d i a t e l y"? For how l o n g? What is the mechanism of "virtual-

"of style"? How often does it happen? In the framework of the ether hypothesis, such problems are solved by the idea of the existence of ether particles as the building material of all material formations, and the idea of the existence of virtual formations is superfluous. The task of describing the mechanistic interactions becomes fundamentally solvable within the framework of modern hydrodynamics. This makes the theory of a viscous gas-like ether attractive for a long time [6, 38-40]. This situation can be solved only by new observations and experts.

Conclusion

Thus, the experimental verification of the hypothesis of the existence in nature of the ether, a material medium responsible for the propagation of electromagnetic waves, has been performed. Within the framework of the initial hypothesis, the effects of ether wind, which can be observed in experiments on the propagation of oscillatory waves in the vicinity of the Earth's surface: anisotropy, height, cosmogenic, hydrodynamic. A first-order optical method for measuring the velocity of the ether wind and the kinematic viscosity of the ether is proposed and realized. Statistically significant measurement results are obtained. The manifestation of the desired **ether wind** effects is shown. The results of systematic measurements can be explained as follows:

- by the presence of a medium responsible for the propagation of optical **waves**;
- by the presence of the relative motion of the solar system and the medium of propagation of optical waves;
- viscosity of the medium of optical wave propagation - a property inherent in material media consisting of individual particles (the value of kinematic viscosity of the medium was calculated and measured, and the altitude dependence of the medium velocity near the Earth's surface was measured);
- the cosmic origin of the flow of the propagation medium of optical waves.

The results of this work are compared with the results of previous experiments performed by different authors to test the hypothesis that such a material medium as ether exists in nature. The observability, reproducibility, and repeatability of the effects of the ether wind in experiments conducted in different ranges of electromagnetic waves, in different geographical conditions, and using different measurement methods are shown, which may indicate the reliability of the results of the study. The results of the work are not

They contradict the provisions of the original hypothesis in MOSST JZZEtCSMATrIvATIoN as experimental confirmation of the ideas about the existence of the ether in nature - a material medium responsible for the propagation of electromagnetic waves.

LiTeratura

1. *Galaev Yu.M.* The effect of the ether wind in the options for the propagation of radio waves // RadrOfizIzIala and electronIha.- Kharkov* Kharkov* ĪNSTIstishchT geaDIO-physIIKi ĩ ZlektronikI4 HAH UKRAINI, 2000.-T.5, № 1.- C.119- 132.
2. *Galaev Yu.M.* Efi Iri-fi-ti BeTep. ExperimentT in the dNapaNe range of radio waves. Zhukovsky: Pegit, 2000.- 44 p.
3. *Galaev Yu.M.* Etheral wind in eXpression of millimetric radiowaves propagation // Spacetime & Substance.- *Khearkov*: Research and Technological Institute of Transcription, Translation and Replication.- 2001.- Vo1.2, No.5(10).- P.211-225. (<http://www.spacetime.narod.ru/0010-pdf.zip>).
4. *Azjukowski i .* Dynamik des Athers // Ideen des exakten Wissens.- Stuttgart.- 1974.- Nu.2.- S.48-58.
5. *Atsyukovsky V.A.* Introduction to Zphyrodynamics. Model Representations of StructurIes of Matter and Fields on the OGNov of Gas-Podobnoy Zfir.- M., MO 1, sec. fsh., 1980.- Dep. VO VNNNTI 12.06.80 r. N-. 2760-80
6. *Atsyukovsky V.A.* ObiIaya eFHQO,QHHftMiKa. Modeling of substance structures on OGHoBe representations of gas-like spheres. - M.: Ergoatomiz, 1990.- 280 p.
7. *Miller D.C.* Ether drift experiments at Mount Wilson solar observatory // Phys. Rev.- 1922.- Vol.19.- P.407-408.
8. *Miller D.C.* Ether drift experiment at Mount Wilson // Proc. Nat. Acad. Amer.- 1925.- Vol.11.- P.306-314.
9. *Miller D.C.* Significance of the ether-drift experiments of 1925 at Mount Wilson // Science.- 1926.- Vol.68, No.1635.- P.433-443.
10. *Michelson A.A., Pease F.G., Pearson F.* Repetition of the Michelson - Morley experiment // Journal of the Optical Society of America and Review of Scientific Instruments.- 1929.- Vol.18, No.3.- P.181-182.
11. *UummeKep E.T.* HISTORY OF Aether and Electricity Geometry. - Izhevsk: NSC Regular and Chaotic Dynamics, 2001.- 512 p.
12. *Michelson A.A.* The relative motion of the Eanh and the Luminiferous ether // The American Journal of Science.- 1881.- III series, Vol.22, No.128.- P.120-129.
13. *Netrash GO., Paymuai S. g.* InterferoMeter Michelsop.- In the book: 'Re-

- M.: SoVet Encyclopedia, 1962.- T.2.- C.202-203.
14. *Michelson A.A. Morley E.W.* The relative motion of the Earth and the lumiuliferous aether. The American Journal of Science. Third Series.- 1887.- Vol.34.- P.333-345. Philosophical Magazine.- 1887.- Vol.24.- P.449-463.
 15. *FpaanKfyfym U.I., FrenK A.M.* OgggnKa moving cpes.- M.: Nauka, 1972.- 212 c.
 16. *Baugwioff C.I.* New Findings of the "ether wind" // YspekhnN ffzichesicheskikh nauk.- 1926.- T.6.- C.242-254.
 17. *Kennedy R.J.* A refreshment of the Michelson - Morley experiment // Proc. Nat. Acad.Sci. of USA.- 1926.- Vol.12.- P.621-629.
 18. *Illingworth K.K.* A repetition of the Michelson-Morley experiment using Kennedy's refinement // Physical Review.- 1927.- Vol.30.- P.692-696.
 19. *Stahel E.* Das Michelson - Experiment, ausgefuP inn Freiballon // Die Naturwissenschaften, Heft 41.- 1926.- B.8, Nu.10.- S.935-936.
 20. *loos G.* Die Jenaer Wiederholung des Mihelsonversuchs. ff *Ann. Phys.*- 1930.- B.7, S.385-407.
 21. *Miller D.C.* The ether-drip experiment and the determination of the absolute motion of the Earth // *Rev. Modern.Phys.*- 1933.- Vol.5, No.3.- P.203-242.
 22. *Essen L.* A new ether drinP experiment // *Nature*.- 1955.- Vol.175.- P.793-794.
 23. *Cedarholm J.P., Bland G.F., Naviance B.L., Townes C.H.* New experimental test of special relativity // *Phys. Rev. Leppers*.- 1958.- Vol.1, No.9.- P.342-349.
 24. *Cyampney D.C., Isaac G.P., Khan M.* Am ether drift experiment based on the Mössbauer effect // *Phys., Letters*.- 1963.- Vol.7.- P.241-243.
 25. *Jaseja T.S., Javan A., Murray J., Townes C.H.* Test of special relativity or of the isovoru of space by use of ilbared masers // *Phys. Rev.*- 1964.- Vol.133a.- P.1221-1225.
 26. *Ethereal BeTep. Cfı. Art. by pen. d.r.n. B.A. Atsyukovsky.*- M.: EnergoaTomNz,O,fiT, 1993.- 289 c.
 27. *Moomtysanxuu L.E* Mechanics of zhilfLKOGTfl and gdza.- M.: Hayxa, 1973.- 848 c.
 28. *CJlezKuhn H.A.* DinamlzKčt Bzi3KOi incompressibleMoi zhilkoGti.- M.: rocòexmdfiit, 1955.- 520 c.
 29. *Paymuaan C G.* Nnterferometer of Rozhdestvensky.- B KH: Physicheskiiy 3Huiklopedicheskiiy clobäjEj.- M.: SoVetskaya 3Hltiklopediya, 1962.- T.2.- C.203.
 30. *Galaev Yu.M.* The measuring of ether-drift velocity and kinematic ether viscosity within optical waves band // *Spacetime & Substance*.- Kharkov:

Research and Technological Institute of Transcription, Translation and Replication.-2002 .- Vol.3 No.5(15).- P.207.-224.

(<http://www.spacetime.narod.ru/0015-pdf.zip>).

31. *Rumshisky II.3.* Mathematical processing of the results of the results of the experiment. - M.: Hayxa, 1971.- 192 pp.
32. *Ragulsky V.* Determination of light velocity dependence on direction of propagation // Physical letters A.- 1997.- Vol.235, No.2.- P.125-128.
33. *Herrman S., Senger A., Kovalchuk E., Müller H. and Peters A.* Test of the Isotropy of the Speed of Light Using a Continuously Rotating Optical Resonator // Physical review letters.- 2005.- Vol.95.- P.150401.
34. *Antonioni R., Okhapkin M., Goklu E. and Schiller S.* Test of Constancy of Speed of Light with Rotating Cryogenic Optical resonators // Physical Review.- 2005.- Vol.A72.-P.066102.
35. *Stanwix P.L., Tobar M.E., WolfP., Susli M., Locke S.R., Ivanov E.N., Win- terfood J., and Kann J. and Kann J.* Test of Lorentz Invariance in Electrodynamics Using Cryogenic Sapphire Microwave Oscillators // Physical Review letters.- 2005.- Vol.95.- P.040404.
36. *Hoek M.* Detennination de la vitesse avec laquelle est entraîné une onde lumineuse vaveursant un milieu en mouvement // Arch. Neerl.- 1868.- Vo1.3.- P.180-185; 1869.- Vol.4.- P.443-450.
37. *Essen L.* A new ether dry experiment // Nature.- 1955.- Vol.175.- P.793-794.
38. *Good L.n.* UraVnenii elektromagnetomechanika dielehtrikoV and model of the World Zfir // DOPOVTDi HAH of Ukraine.- 2003.- MatematI-ka, PrOdOzOzNaVstvo, TehnIchnIchnIchnI Sciences.- No. 10.- C.62-69.
39. *Good N.L.* Dv ONTiiinumNaia Mechanika dielehtrikii as the basis of the Zpectromagnetomechanics // Applied Mechanics.- Kiev: INGT T Mekhaniki HAH of Ukraine.- 2003.- T.39, No.8.- C.28-47.
40. *Good N.L.* Construction of dynamical equations of electroMagneto- mechanics of dielectrics and piezoelectrics on the basis of dV OHT M- of naya Mekhanika // Physico-MaTeMaTeMaTeMaTriuNe modeluNg ha iHfOJEmdvjffHI gehNologii. Science Collection.- Lviv: Center for Mathematical Modeling of the Institute of Advanced Problems of Mechanics and Mathematics of HAH Ukraine.- 2006.- Issue 3.- C.177-198.
41. *Fipytraia.-* In KH.: Physiological Encyclopedia.- M.: Bolshaya Ros. eniklopedia, 1998.- T.5.- C.323.

НАЦИОНАЛЬНАЯ АКАДЕМИЯ НАУК УКРАИНЫ

institute of Acoustics and ELECTRONICS

12, Akademika Iroskura str., Kharkiv, 61085.

Senior Research Fellow

Yuri Mikhailovich Galaev

Ph.D., S.S., Corr. Member of PAEH

Tel. : 38 (057) 7-37-01-52 Mo6.: 38-096-292-14-77

E-mail: galae@ire.kharkov.ua

Galasv Y. M.
GI Vimir speed ephemeral wind and
kinematic viscosity of ether by optical interferometer. -
Kharkiv: TOV "Infobank", 2007, 44 pp. il. 9

ISBN 978-966-8464-07-2

Experimental verification of the hypotheticality of ether. An optical method for measuring the velocity of ether wind and the cinematic viscosity of ether was developed and implemented. The results of the systematic research are summarized from the results of the research carried out in the radio and optical ranges. The kinematic coupling of the ether has been calculated and measured. The results of the experiment are not in conflict with the provisions of the third hypothesis and can be regarded as a confirmation of the idea of the existence of ether in nature. The negative results of the Michelson-Morli-Morli-researches are explained by the lack of sensitivity of the measuring instruments.

1705010000 -19

8464 - 2007

No obv'y.

BBK 22.3.

Scientific edition Yuri

Mikhailovich Galaev

AIR BETPA SPEED MEASUREMENT
And KIPEMATnCe viscosity eFi A
OPTICAL INTERFEROMETER

Published in the author's edition

State Register DK № 1069 of 03.10.2002
Printed 25.07.07. Format 60x84 1/16
Usl. pec. l. 2,75. Circulation 300 copies. Order N- 19
Publishing house LLC "Infobank",
ul. Sergiy Tapxooa, 9, k. 15, Kharkiv 61189, Ukraine, tel.
+38 050 230-12-26, +38 050 301-43-3 1

Printed at Fnarze Ltd,
r. Kharkov, Lenin Ave. 36, office. 420,
tel. +38 057 7176-002, 7175-826. 420,
tel. +38 057 7176-002, 7175-826.