

Towards Synergy of Wireless Energy Transmission and Communications

Slobodan Nedić

Faculty of Technical Sciences, UNS, Trg Dositeja Obradovića 6, 21000 Novi Sad, Serbia, nedics@uns.ac.rs

Keywords: Longitudinal Electromagnetic Waves, Advanced Electromagnetism, Future Wireless Communications
Ondes Électromagnétiques Longitudinales, Electromagnétisme Avancée, Communications d'Avenir

Abstract

Outgoing from general expectations that the longitudinal electromagnetic waves generating, propagation and reception could support wireless energy transmission and power-efficient wireless communications, this paper attempts to contribute to overcoming limitations and constraints of the classical Maxwell's equations framework. In particular, it goes about conciliating the critics and the only proponent of theoretical and practical aspects of the so-called scalar waves technology, by relying on a few of important work results on scrutinizing the very Maxwell's equations foundations. The motivation is found in the apparent need for the paradigmatic shift in the ways the modern wireless networks radio links, topology and energy supply are designed and operated, and the quite contradictory expectations on part of the network performance regarding the throughput increase and the energy consumption decrease targeted by the recently initiated and currently ongoing development and standardization of 5G system. The synergetic approach between wireless energy transmission and communications then falls in line with Tesla's more than a century old views, convictions and works.

Résumé

En partant des attentes générales que les ondes électromagnétiques longitudinales pourrait soutenir la transmission de l'énergie et de la puissance-efficace de communication sans fil, le document présent une tentative de surmonter les limites et les contraintes imposés par le cadre des équations classiques de Maxwell. En particulier, elle se-concilie les critiques avec le seul promoteur des aspects théoriques et pratiques de la soi-disant technologie des ondes scalaires, en s'appuyant sur quelques-uns des importants résultats de analyse avec le pointage sur des fondations des équations de Maxwell. La motivation est trouvé dans le besoin apparent pour changement de paradigme dans la façon que réseaux sans fil contemporaines sont conçus et exploités, et les attentes contradictoires sur la part de la performance du réseau concernant l'augmentation de débit et de la diminution de la consommation d'énergie visés par la recent lancement et actuel développement et la standardisation de système 5G. La synergie entre de transmission sans fil de l'énergie et de la communication tombe alors dans la ligne avec plus d'un siècle vieux opinions, des convictions et des œuvres de Tesla.

Introduction

The explosive growth of cellular and sensors wireless networks poses requirements on hundreds to thousands times increase in traffic throughput, while at the same time on order of tens to hundreds times decrease in consumed energy and communications latency. In spite of tremendous efforts in the engineering and communications community to respond to these challenges, notably reflected in the recently issued Horizon 2020 ICT Call 14 related to the Fifth Generation (5G) wireless cellular standard development by further enhancing and extending the multiple-input/multiple-output (MIMO) configurations and more advanced communications waveforms and protocols, as well as promotion of small cells deployment to reduce the capital and operating expenses, its success is questionable without a radically new approach.

The currently exploited transversal electromagnetics propagation mechanism imposes radiation of antenna elements in all directions so that on the average only a millionth part of the radiated energy acts at the intended destinations, including the ("massive") MIMO systems, which only ensure the energy emitted from the multiple antenna elements to be constructively added (the signals 'phased') at the reception site, while the rest remains wasted. The alternative, that is the coexistent longitudinal electromagnetic propagation mechanism have been 'thrown-out' from the official electrodynamics, formulated by simplifications introduced by Heaviside, Hertz and Gibbs based on contemporary well established Ampere's and Faraday's laws, resulting in absence of divergence of magnetic induction (\mathbf{B}) and the temporal variability of the electric induction (\mathbf{D}). The righteousness of the very early Tesla's insistence on existence and importance of the longitudinal mechanism have recently been attempted, notably by Prof. Konstantin Meyl [1], in particular the most recent formulation after discovery of magnetic monopoles in the Helmholtz Institute some six years

ago, as well as extensions of electromagnetics equations by Gennady Nikolaev [3] (introduction of the “second”, that is longitudinal magnetic field as result of non-zero divergence of the magnetic vector potential, A and Vladimir Atsukovsky [2] (involvement of the time-variable electro/magnetic induction). The latter one provides the very much compelling representations of the realm of electromagnetics as dynamics of the particular viscous and compressive gaseous fluid which allows for formation and disintegration of toroidal vortex structures, [4][5], implicitly supporting the gyroscopic particles (magnetic monopoles) as the basic elements of the Ether substance. As demonstrated by the Tesla’s Magnifying Transmitter (MT) configuration, which has been replicated many times in particular within last two to three decades, the energy transmitted by mediation of the so-called Scalar Waves is thought to be circulating in the system until being absorbed by the matched receiver. However, although Tesla had talked about propagation of such waves in the Ether, what he essentially attained was the longitudinal, progressive standing waves through earth and/or ionized media. While here apparently the part of the electromagnetic perturbation which has the direction of propagation of energy, the recently largely actualized “linear magnetism” (magnetic field vector co-linear with the direction of energy propagation) appears to be the crucial phenomenon relevant to both supra-luminal transmission speed and energy efficiency in free air or vacuum.

Besides a radical reduction of transmitted energy losses for both SISO and MIMO systems, the prospectively resulting comparable transmit- and receive-signal levels can potentially greatly alleviate the problem related to necessity of suppressing the (local) Tx-to-Rx chain signal leakages on the order of 100 dBs – the task implying big if not insurmountable difficulties regarding both the carrier signals phase jitter and digital signal processing, in particular for the millimeter wave radio ranges and beyond, needed for availability of larger bandwidths. In relation to the related echo-cancellation operation and functionality of the targeted full-duplex radio transmission, there exists the problem of the so-called Transmitter Noise which has not been enough explicated/treated in the existing (sub 6 GHz) research and test-bench implementations. With an emergence of understanding the near-field radiation as at the same time the cause of transmitter noise and actually representing the longitudinal (i.e. “scalar”) waves, with appropriate EM formulation the room may start opening for it’s treatment as a structured rather than a random process modeled entirely as a white noise.

Although the primary usage of the Tesla’s waves have by himself been conceived for both energy supply and communications purposes, the energy transmission has been and remained his main goal, with the synergetic inclusion of the (land, sea and air) vehicles’ controlling functionality. While the wireless energy transmission on itself can be considered as a much more advantageous (in terms of energy losses – in Tesla’s one-wire system the energy actually flows around the very thin conductor ?!), its significance in the domain of wireless cellular and sensors network application becomes very welcome if not even indispensable. The desirable and in terms of (for network expansion and densification) much promising deployment of small cells will need not only the wireless relaying-based backhauling to the nearest (back-bone network) connected base-station, but most likely the particular site might be as well lacking the standard utility-based power supply. In the case of sensor’s networks, as well as the foreseen machine-to-machine (M2M) communications, the problem of battery-based operation can be largely overcome, whereby the initial supply of energy can serve as wake-up stimulus for dormant stations, similar to the way the conventional RFID components are operated.

Whereas paradigmatically changed basic communications principle and its implementation on link-level will likely imply changes in the existing networking protocols, in case of sensors’ networks, for example, depending on the true underlying mechanism of the Tesla-like energy transmission (resonant cavity based, longitudinal/scalar waves or non-linear dynamics related ones) the protocols might come in the range from unilateral central initiation and receiving response from concentrically located sensors in the multiple-input/single-output (MISO) manner, to centralized sensing of receiver-end energy absorption. The cellular networks related communications protocols would be similarly modified.

In the 5G wireless network envisioning, in the conventional cellular as well as in M2M communications, the implied large increase of interference and its management becomes a very important issue. Instead of treating the interference just as a nuisance, the “scalar waves” technology might offer a way for its reuse, that is its ‘recycling’, as a form of or supplement to energy harvesting. There namely are certain indications that the longitudinal electromagnetic propagation relies on the existing man-made electromagnetic disturbances as well as on the very basic Ether energy environment.

In the following, the Section 1. contributes to overcoming limitations and constraints of the classical Maxwell’s equations framework. In particular, it goes about conciliating the critics and the only proponent of theoretical and practical aspects of the so-called scalar waves technology, by relying on a few of important work results of other authors on scrutinizing the very foundations Maxwell’s equations and their extension, or amelioration. The underlying fundamental framework is the ubiquitous presence of the Ether substrate.

The overview of existing demonstration of the transmissions in general, and in particular through charge-free media will be given in Section 2., including separate energy transmission and the means for communication of information and followed by an outline of the possible synergetic approach between wireless energy transmission and communications. Finally, due to high relevance in general, and in particular for the topic of this paper, energy harvesting and distributed, that is localized and self-sustained energy generation is briefly addressed, as variation of the well-known inductance coil.

1. Controversies and prospects of establishing consistent and generalized electromagnetics framework

Ever since their introductions by Maxwell in the second half of the nineteenth century of the set of linear differential equations and subsequent reformulations and simplifications by Heaviside and Gibbs to essentially involve the vector analysis notations instead of the quaternions algebra, despite occasional difficulties in their application to diverse practical problems, they have essentially retained their original form:

$$1. \operatorname{rot}\mathbf{E} = -d\mathbf{B}/dt \quad (1.1) \quad 2. \operatorname{rot}\mathbf{H} = \mathbf{j} + d\mathbf{D}/dt \quad (1.2) \quad 3. \operatorname{div}\mathbf{D} = \rho \quad (1.3) \quad 4. \operatorname{div}\mathbf{B} = 0 \quad (1.4)$$

Here \mathbf{E} and \mathbf{H} are respectively the electric and magnetic field strengths; $\mathbf{D} = \varepsilon\mathbf{E}$ and $\mathbf{B} = \mu\mathbf{H}$, respectively, electric and magnetic inductions; ε and μ are the electric permittivity and magnetic permeability of the medium, $\mathbf{j} = \sigma\mathbf{E}$ is the current density; σ — electrical conductivity of the medium; ρ — density of electric charge in the medium. The vectors (letters in Bold) and scalars (other than constants) are generally functions of position w. r.t. a coordinate system origin and the time.

With advent of the Special Theory of Relativity and the subsequent developments of the quantum mechanics, the solutions of these equations have been more and more conducted in rather abstract terms, the sense of the original reliance on the vacuum as the substrate of propagation of electro-magnetic perturbations has become completely obsolete. In that sense, besides the absence of magnetic charges ($\operatorname{div}\mathbf{B}=0$), the existence of the electric charges within vacuum ($\operatorname{div}\mathbf{B}=0$) has been denied as well, and while in conventional formulation $\mathbf{E} = -\operatorname{grad}\varphi - d\mathbf{A}/dt$ the scalar (electric, $\varphi(\mathbf{r},t)$) potential has a physical meaning of the work that has to be done to move a unit charge from infinity to a given point in the electric field, the vector (magnetic, $\mathbf{A}=\operatorname{rot}\mathbf{B}$) potential has only a purely mathematical sense as some auxiliary function, which is only of methodological value. Contrary to such views, there are ground to argue for its true physicality.

The above Maxwell equations have differential form. To them correspond electrodynamics equations in the integral form

$$1. \text{Faraday's law of electromagnetic induction} \quad e = \oint_l \mathbf{E} \cdot d\mathbf{l} = -d\Phi_M / dt \quad (1.5)$$

$$2. \text{Total current law} \quad i = \oint_l \mathbf{H} \cdot d\mathbf{l} = dq / dt \quad (1.6)$$

$$3. \text{Ostrogradsky-Gauss theorem for electric field} \quad \Phi_e = \oint_s \mathbf{D} \cdot d\mathbf{S} = q \quad (1.7)$$

$$4. \text{Ostrogradsky-Gauss theorem for magnetic field} \quad \Phi_M = \oint_s \mathbf{B} \cdot d\mathbf{S} = 0 \quad (1.8)$$

Here Φ_e and Φ_M , respectively, are flows of the (dielectric) displacement, that is electric induction \mathbf{D} and magnetic induction \mathbf{B} through a closed surface S , encompassing the free charge (respectively q and 0).

A direct critic of these equations is hardly to be found in the open literature. The only two rather comprehensive treatises are [2] and [3], based on extensive sets of experiments and complementary regarding respective emphasis on electric and magnetic aspects of the electromagnetic field. While both authors rely on etherical nature of electricity and magnetism, the first one has developed a consistent and very compelling model of Ether as a gaseous substance with viscosity and compressibility features. In the following is provided an overview of the main findings, with main emphasis on [2].

Related to the very comprehensive treatise of Atsykovsky (translation¹ of the most Section 6 in [2] – in Appendix):

In his very long carrier as electrical engineer and academician, based on insights into Ether substrate as a gaseous substance exhibiting both compressibility and viscosity – the features that either one or both were missing from all previous conceptualizations and postulations, Atsukovsky has developed a very consistent and compelling theory of Etherodynamic, comprising all structures and phenomena from the atomic to galactic levels [11].

Based on this this, Atsukovsky has come up with differential equations of the electromagnetic field taking an extended and largely improved form:

$$\operatorname{rot}\mathbf{H}_\psi \Leftarrow \delta_e = \left(\sigma + \varepsilon\varepsilon_0 \frac{\partial}{\partial t} \right) (\mathbf{E}_\varphi + \mathbf{E}_\Sigma) \quad (1.9)$$

$$\operatorname{rot}\mathbf{E}_\varphi \Leftarrow \delta_M = -\mu\mu_0 \frac{\partial}{\partial t} (\mathbf{H}_\psi + \mathbf{H}_\Sigma) \quad (1.10)$$

$$\operatorname{div}\mathbf{D} + \frac{\partial\mathbf{D}}{c\partial t} = \rho; * \quad (1.11)$$

¹ With approval of the book's author.

$$\operatorname{div} \delta_e + \frac{\partial \delta_e}{c \partial t} = 0; * \quad (1.12)$$

$$\operatorname{div} \operatorname{grad} \mathbf{B} + \frac{\partial \operatorname{grad} \mathbf{B}}{c \partial t} = 0; * \quad (1.13)$$

Here \mathbf{D} — vector of electric induction, δ_e — vector of electric current density in a medium, \mathbf{B} — vector of magnetic induction. The note that goes along the equations marked by ‘*’ is that division of vectors \mathbf{D} , δ_e , and $\operatorname{grad} \mathbf{B}$ by vector c means that those vectors are collinear, that is they have strictly one and the same direction.

The first feature of the extended, that is largely improved set of differential Maxwell’s equations are two forms of asymmetry introduced – regarding the cause-effect (the first two equations do not apply in both directions) and presence of generally different electric and magnetic field strength vectors, both in the first two equations. (The additional terms within the brackets denoted by index ‘ Σ ’ stand for the fields components external to the considered elementary volumes of the medium, and more close elaboration and justification of that can be inferred from the text in the Appendix.) These asymmetries might be the features that were inherently present in Maxwell’s second and third formulations of electromagnetism based on Quaternions-algebra, due primarily to the non-commutativity of the multiplication operation.

The second extension featured by the ‘ameliorated’ Maxwell’s equations are the non-zero divergences of both electric and magnetic fields (the third and second equations) in absence of the free-charges, arrived at exactly based of the dynamical features and the Ether regarding the compressibility. Implicitly, the related electric and (the gradient of) magnetic inductions are ‘intimately’ related to the(ir) velocity of propagation through to the quite unusual division of the two vectors. Other than looking at this operation as conventional scalar multiplication in that the velocity vector is ‘inverted’, this should rather be treated through the so-called the real division algebra, where quaternions represent basis.

The extended integral equations take the form

$$e = \oint_l \mathbf{E}(t - r/c) \cdot d\mathbf{l} \Leftarrow -d\Phi_M(t)/dt \quad (1.14) \quad (1.15)$$

$$e_M = \oint_l \mathbf{H}(t - r/c) \cdot d\mathbf{l} \Leftarrow i(t) - dq(t)/dt$$

$$\Phi_e = \oint_s \mathbf{D}(t - r/c) \cdot d\mathbf{S} \Leftarrow q(t) \quad (1.16) \quad (1.17)$$

$$\Phi_M = \oint_s \mathbf{B} \cdot d\mathbf{S} = 0$$

Here e and e_M — electric and magnetic potentials difference; Φ_e and Φ_M — electric and magnetic flows (fluxes); i — electric current in conductor; q — charge moving in direction of electric current (directed movement gives it the vector form).

The first expression – Faraday’s law of electromagnetic induction and the second one – law of total current differ from the common forms by presence of retardation (delays).

The above equations of the electromagnetic field having Maxwell’s equations as special case are valid for the electromagnetic wave front, but in some cases allow to solve some problems that cannot be solved on the basis of Maxwell equations, for example the problem of radiation of a dipole with lumped parameters in a semiconducting environment. Under certain conditions in such a dipole, the main share of energy will not be distributed transverse relative to the vectors \mathbf{E} and \mathbf{H} direction, but in the direction of the vector \mathbf{E} and perpendicular to the vector \mathbf{H} . This longitudinal propagation of the electromagnetic field practically has not been yet properly studied, although it has been experimentally confirmed.

It should be noted that by what was indicated above should not be finalized refinement of equations of electromagnetic field. That process should continue all the time, until arises necessity for a more and more complete solution of applied/practical problems. For example, in the future, in formulating the Law of the total current the fact of the ether compressibility should be taken into account, therefore, the compressibility of the very magnetic field and the corresponding change/modification of the hyperbolic decrease of the magnetic field near the conductor. In that way, the etherodynamics’ conceptions allow to make more accurate the formulation of electromagnetism in certain cases to a significant extent. The conducted improvements by all means are not complete yet. Description of the electromagnetic field, as well as any physical phenomenon, can be refined limitlessly in accordance with the number of aspects and properties of the fields encompassed by the models, because total number of aspects of any phenomenon is very large.

Related to Nikolaev's 'opus' (mostly excerpts from the introductory and the prefacing parts in [3]):

While he has been pointing to deficiencies of the Maxwell's equations mostly in similar aspects as did Atsukovsky (referred to only as an example of the people which came from the academia circles, and still have scrutinized the classical electromagnetics/electrodynamics foundations), Nikolaev addresses them primarily from the point of view of applicability of the magnetic vector potential \mathbf{A} . On one side, he pursues and exploits the physicality of the (vacuum) displacement current (rate of change of the electrical induction field \mathbf{D}) when it comes to overcoming the inconsistencies of the Maxwell's equations regarding the problems of non-locality, and on the other, overcomes the lack of correspondence of the measurement results in case of open-current loops (for example, linear dipole antenna) with calculations when only one component of magnetic field ($\mathbf{H}=\text{rot}\mathbf{A}$) is evaluated (with known distribution of displacement current), while as usually assuming that $\text{div}\mathbf{A}=0$. Namely, in such situation, the produced solution does not satisfy the outgoing Maxwell's equations. The full correspondence gets attained only with the non-zero magnetic vector potential.

The problem that led Atsukovsky to augment the right-hand side of the 1st Maxwell's equation in differential form is treated by Nikolaev in the context of the evident presence of the electric field around the transformer, while the time variation of the magnetic field does not take place ($\partial\mathbf{H}/\partial t=\mathbf{0}$), that is

$$\text{rot}\mathbf{E} = -\frac{1}{c} \frac{\partial\mathbf{H}(\mathbf{r})}{\partial t} = \mathbf{0} \quad ; \quad \text{div}\mathbf{E}(\mathbf{r}) = 0 \quad (1.18) \quad (1.19)$$

so that the induced electric field should be zero.

As for the integral form of the 1st Maxwell's equation, it has been revealed a formal nature and obvious limitation of the known conceptualization of the very vector-magnetic field $\mathbf{H}=\text{rot}\mathbf{A}$ and of "magnetic flux" of that field through the surface of a contour. For example, it is known that by solving concrete practical tasks the fundamental equation of electromagnetic induction in integral form ($1, 2$ are two parallel longer sides of a rectangle shaped conductor, and 3 and 4 the sides perpendicular of them)

$$e' = \oint_{1234} \mathbf{E} \cdot d\mathbf{l} = \frac{1}{c} \frac{\partial}{\partial t} \int \mathbf{H} d\mathbf{S} = e'_1 + e'_2 + e'_3 + e'_4 \quad (1.20)$$

is found to be in sufficient correspondence with results of experimental observations at determining the EMF only for closed contours, however by this equation predicted distribution of the electric field along the sides of the contour considered separately gets in clear contradiction with experimental results [9]. Moreover, by virtue of formal conception of a "magnetic flux", the principal limitation of the concept of electric current induction in a contour by the time-varying "magnetic flux" also gets revealed. If a closed contour is permeated by a magnetic flux changing in time ($\partial\Phi/\partial t \neq 0$), for example produced by a moving electric charge (or a segment of such charges), then contrary to the obvious requirements of dependence in (1.20), the resulting EMS in such a contour turns out to be $e=0$ (reference [16] in [3]), i.e. there follows inequality of the form

$$-\frac{1}{c} \frac{\partial\mathbf{E}}{\partial t} = -\frac{1}{c} \frac{\partial}{\partial t} \oint \mathbf{H} d\mathbf{l} \neq \oint \mathbf{E} d\mathbf{l} = e = 0 \quad (1.21)$$

On the other side, however, in electrodynamics in general are known still other methods of determination of the induced (rotational) electric field \mathbf{E} , in the framework of the formalism of the magnetic vector potential \mathbf{A} in the form

$$\mathbf{E}(\mathbf{r}) = -\frac{1}{c} \frac{\partial\mathbf{A}(\mathbf{r})}{\partial t} \quad (1.22)$$

Therein it becomes amazing that by help of this equation, thus without conceptions of "magnetic field" and "magnetic flux" the true distribution of the induced electric field \mathbf{E} along a closed contour becomes easily established from the simple dependence

$$e = \oint_{1234} \mathbf{E} \cdot d\mathbf{l} = -\frac{1}{c} \frac{\partial}{\partial t} \oint \mathbf{A} d\mathbf{l} = e_1 + e_2 \quad (1.23)$$

Besides this, the (magnetic) vector potential formalism in (1.22) becomes also applicable for describing of electromagnetic induction of current outside of the transformation core, because outside of the core at condition $\partial\mathbf{H}/\partial t=\mathbf{0}$ still it is $\partial\mathbf{A}/\partial t \neq \mathbf{0}$. Consequently, it can with sufficient certainty be ascertained that the formalism of the vector potential \mathbf{A} much better corresponds to experimental observations than the Maxwell's formalism of magnetic field and magnetic flux do.

The main result that Nikolaev came up with, and which may have some relevance in the subsequent considerations in this paper, is related to the necessity to generally account for two forms of the magnetic field – the conventional, ‘normal’ to direction of a current ($\mathbf{H}_{\text{nor}} = \text{rot}\mathbf{A}$) and the new one, with direction parallel to current flow ($H_{\text{par}} = -\text{div}\mathbf{A}$). The latter component Nikolaev named *the second* or *scalar magnetic field*, and could be related to recently introduced ‘linear magnetism’ related to electromagnetic activities of biological structures and ‘elements transmutations’. The physicality of this field component has been demonstrated in experiments with interactions of conductors situated co-linearly (along the same line) with each other, as well as with a permanent cylindrical (and torus-form) magnet cut in half along its length and re-assembled in the same form after one of its halves is rotated by 180° (without any resistance – the magnetic forces perform this re-configuration by themselves, which according to S. Marinov provided basis for ‘perpetual mobility’) around the ‘axis’ perpendicular to the cylinder axis. Moreover, while in accordance with the Lenz-s law the current induced in a part of a conductor (with sliding contacts on its ends) being moved perpendicularly to a vector(ial) magnetic field ($\mathbf{H}_{\text{nor}} = \text{rot}\mathbf{A}$) flows in such a direction so that resistance to its movement arises, in the case of scalar magnetic field, surprisingly, the longitudinal movement of the same conductor segment within the scalar magnetic field will actually be aided in that movement !?! This can then be termed the anti-Lenz effect. (It has been noted in Preface of [3] that the first one who observed the longitudinal movement of a segment of conductor on sliding contacts was Carl Hering, with effects described in Transactions of American Institute of Electrical Engineers, **42**, 311, 1923, which was reprinted in the S. Marinov’s journal Deutsche Physik, **1**(3), 41, 1992. Hering has a patent on a transformer based on mutual compensation of the involved magnetic fields. The very recent results [10], where a ‘complexly’ coiled-coil, i.e. “vector-potential coil” was created to generate a curl-free vector potential to transfer the voltage to a straight-line superconductor playing the role of secondary ‘coil’, whereby the “non-magnetic” output voltage was detected to be the same as at the output of a regular copper wire secondary coil, while the presence of an ideal magnetic shielding did not present any hindrance!?)

(Total force acting on a segment $d\mathbf{r}$ with electric current I consists of the Lorenz and the Scalar terms

($\mathbf{F} = \mathbf{F}_L + \mathbf{F}_S = I \cdot d\mathbf{r} \times \mathbf{B} / c + I \cdot d\mathbf{r} \cdot \mathbf{S} / c$) and for a set of moving charges q_i with velocities \mathbf{v}_i and positions defined by \mathbf{r}_i the best effort scalar force expression arrived at (by the late Stefan Marinov, found in Preface of [3], who actually denoted the collinear magnetic field as the “Second Magnetic Field of Kolya Sibirsky” and worked a lot on it) is

$$S = -\text{div}\mathbf{A} - \sum_i (q_i \mathbf{v}_i \cdot \mathbf{n})(\mathbf{r}_i \cdot \mathbf{n}_i) / c r_i^3, \quad \mathbf{n} = \mathbf{r} / r .$$

Since the presence of the magnetic scalar field and the related force can be of importance generally, including energy harvesting and even the overunity energy generators, and of course in the context of energy transmission and communications, all this at least indicates the need and possibilities of an adequate electromagnetics/electrodynamics theoretical and analytical framework formulation, by overcoming the traditional constraints and long-held views/convictions regarding non-availability of longitudinal, that is scalar mechanism generated and propagated in the Ether as vacuum substrate.

Considering this and the well-known detectability of the magnetic field effects even in case(es) when the magnetic field intensity does not exist (its intensity zero – the famous Aharonov-Bohm experiment in 1956), some of recent engineering practices [10] and, finally, non-uniqueness of a magnetic vector potential regarding its curling measure representing the same (‘normal’) magnetic field ($\mathbf{A}' = \mathbf{A} + \text{grad}\Psi$ and $\mathbf{H} = \text{rot}\mathbf{A}' = \text{rot}\mathbf{A}$, at least for time-independent scalar potential Ψ) actually suggest that it must be representing an aspect of the real (dynamical) structuring of the very Ether substrate. (One of possible so-called gauge-transformations, the (Ludwig) Lorenz’s one, is $\text{div}\mathbf{A} = -\partial\phi / \partial t$.) It then appears that, along the implicit ‘plurality’ of electric scalar potential ϕ regarding its space-time variability, it goes only about particular constraints set whether the set of possible solutions of adequately formulated equations of electrodynamics will provide wider, narrower or just singled-out solutions, being in full agreement with ‘ideal’ observations!?!)

Based on conceiving the Ether as a gaseous fluid of elementary particles, named “a’mer(s)” (in tribute to Demokrit), exhibiting both viscosity and compressibility, in difference to all previous models, including the Maxwell’s, Helmholtz’s, Lord Kelvin’s, etc., in [2], and in [11] in a more general context of universe on all scales (essentially tied in itself in a kind of ‘recycling’ process), Atsukovsky has established a basic, essentially dynamically stable toroidally shaped structures, which further organize into higher level configurations through the very basic mechanism of velocity/temperature/pressure gradients, the very same mechanisms by which at certain stages the structures get disintegrated. Regarding the very basic proton and electron configurations, it goes about the flows of the Ether fluid elements around the torus-like geometry, in that its velocity in the ring direction lies in the nature of electricity (plus sign, in one direction; minus sign in the other), while the velocity of the very same “fluid” elements over ‘meridians’ of the same torus represent the magnetic charges. The corresponding attractive and/or repulsive forces (respectively proportional to inverse square and cube of distance) are related, respectively, to counter-directed and same-directed flows. In a way, this comes to be similar to the way the toroidal transformers are designed and built in the engineering practice, including those which exhibit quite unique effects as the linear magnetism (Rodin coils) and magnetic monopole structures (half-ball shaped Tesla’s bifilar flat coil, as recently configured in CERN, and replicated in context of artificial creation of various dynamically stable configurations produce from plasma, that resemble many a structures form atomic to galactic levels, Prof. Lapoint at MIT <https://www.youtube.com/watch?v=9EPlYiW-xGI>; the half-dome coil at

<https://www.youtube.com/watch?v=i-dhIK2ozz0>

This has a strong support in some of the formulations of generally non-linear fluid dynamics equations, where the fluid element represents a tiny elongated gyroscopic (with rotation along its axis) ‘prism’ (featuring the precessional effects, which might account for both the viscosity and compressibility features), [4], and (in light of discussion above) a kind of an omnipresent sponge with a huge ‘spaghetti’, which represent a latent capability for creation of any of imaginable vector (magnetic) potentials, and/or monopole-like ‘charges’, whether of (di-)electric or magnetic types. In that sense, the effective electric and magnetic charges can arise under influence of remote (material-ized ones), due to process of intermediately propagated induction, so that the conventional constraints regarding their absence in vacuum ($\text{div}\mathbf{D}=0$ and/or $\text{div}\mathbf{B}=0$) become unnecessary limiting and thus should largely become obsolete. (Here apparently lies essential difference between electromagnetic and light phenomena, in that light is continually propagating dynamic highly-stable toroidal vortex - photon structure, with the only common feature with EMs being speed of transversal propagation [2].)

1.1. Longitudinal versus transversal ‘nature’ of the electromagnetic equations – the long standing controversy

Ever since the Maxwell’s formulation of (firstly entirely algebraic, and later in the form of quaternions algebra, bearing much wider group asymmetry than tensors, and let alone vectors which remained in the wide use as of today) equations that describe the electromagnetic phenomena, there have been no explicit constraints on the form of the related waves. Actually, the starting point was purely mechanical analysis and formulation of transmission of momentum through a medium, so that only its nature and features were to determine if generally both transversal and longitudinal or just one of them would be manifest². Unfortunately, the course of historical development was such that due to available set of experimentally confirmed heuristically derived laws on one side, and the postulated (ideal) features of the involved Ether medium (homogeneity, incompressibility and non-viscosity) on the other, a rather paradoxical situation arose – only availability of the transversal waves has ‘survived’, in spite of the ideal medium which actually should not allow them!?!

On those grounds, and based on his own experimental (in his Colorado laboratory) evidencing of the longitudinally traveling EM-waves, Tesla had claimed that if Hertz had produced reception of whatever oscillations originated at a dislocated transmitter, that might actually must have been happening through the longitudinal, and not through the transversal mechanism, since Tesla was opting for the Ether’s compressibility (ability to ‘shuttle’ in direction of propagation) but apparently did not admit (certainly wrongly, sine not having been aware of its viscosity) the very possibility of appearance and/or propagation of transversal effect. (He, though, still kept distinguishing between his, Tesla’s waves and the Hertz-ian waves?!) Whatever the situation might have been, the above exposed/replicated treatise of V.A. Atukovsky undoubtedly provides foundations for both electromagnetic perturbations and their subsequent propagation through vacuum, that is through Ether, and not allowing for the presence of longitudinal waves only in material media. This in turn can reaffirm some earlier findings, as Heaviside’s odd and nearly incredible giant curled EM energy flow component actually accompanying every far more feeble Poynting energy flow in every EM system or circuit (it definitely would be interesting to see if it may bear any relationship with the Second magnetic field of Kolya Sibirsky), and going beyond what Helmholtz and Lord Kelvin had, towards reaffirming of the Des Cartesian vortex physic³. Notwithstanding the historical aspects and the missed opportunities, the modern stances are scrutinized bellow.

In the context of the Laplace’s homogenous (classical) wave equation

$$c^2\Delta W = \partial^2 W / \partial t^2, \quad (1.1.1)$$

its general solution has the form

$$W(\mathbf{r}, t) = W(t \pm \mathbf{r} / v), \quad (1.1.2)$$

where v represents the velocity of propagation, including the linear combination thereof. As a matter of fact, (1.1.1) had actually been derived by pre-supposing that very same ‘oscillatory-waving’ process, as outlined within brackets bellow.

By using the vector algebra identity for the Nabla (or Laplace, ∇^2) operator on the left-hand side of (1.1.1) it can be written as

$$c^2(\text{graddiv}W - \text{rotrot}W) = \partial^2 W / \partial t^2 \quad (1.1.3)$$

² The LWave is the traveling (and/or stationary) longitudinal counterpart to the traveling (in modern terminology – transversal) electromagnetic (TEM) wave. Using the terminology from Maxwell’s original treatises, it can be written as a longitudinal wave in the electromagnetic momentum where the electromagnetic momentum is curl-free (or nearly so). Langmuir’s electrostatic plasma wave is one concrete example of a LWave. A brief account of the related historical development is to be found at <http://maxwellfluidcompression.blogspot.rs/>

³ As an important proponent of such approach one has to refer to Prof. Evert (<http://merlib.org/node/105>).

(For scalar, one-dimensional wave process $u(x, t)$, for example, it was taken that $u(x, t) = u(x - vt)$, that is the same $u(\xi)$ is being moved along the x -axis, so that its particular value retains same at locations and time instants which satisfy $\xi = x - vt$. Moreover, by formal differentiation it follows $\partial u / \partial x = (du / d\xi)(\partial \xi / \partial x) = du / d\xi$ (a); $\partial u / \partial t = (du / d\xi)(\partial \xi / \partial t) = (-v)(du / d\xi)$ (b), thus $\partial u / \partial t = (-v)(\partial u / \partial x)$. By considering the first derivative of $u(\xi)$ over ξ as presenting another function of ξ , that is $w(\xi) = du / d\xi$, it (i.e. $w(\xi) = w(x - vt)$) also can satisfy the two conditions to represent another propagating wave which then satisfies $\partial w / \partial t = (-v)(\partial w / \partial x)$ (c), by replacing therein $w(\xi) = du / d\xi$ by the left-most part of equation (b) to the left-hand side of equation (c) and the left-most part of equation (a) to the right-hand side of equation (c), one gets $\partial^2 u / \partial t^2 = (v^2)(\partial^2 u / \partial x^2)$, which moreover is satisfied by superposition of two waves with generally different profiles, propagating in opposite directions: $u(\xi) = f(x - vt) + g(x + vt)$. Despite apparently heavily constrained, this classical wave equation can be used for analysis and prediction of general form of classical string oscillations, including transverse (shape) and longitudinal (density) propagating mechanism. At <https://www.youtube.com/watch?v=fDfISEETFkM> it can be seen that the two velocities are generally different, the later one exceeding the former to the extent the strain in the string is reduced. At a very basic level it may indicate similar relationship in the EM realm.)

This was essentially exploited and varied in the early stage of work of Prof. Meyl [1] towards formulation of the electromagnetic equations which would encompass both transversal and longitudinal waves propagation mechanism in vacuum, that is in a medium without free charges. In doing so, essentially the first and the second Maxwell's equations are taken ($\text{rot}\mathbf{E} = -d\mathbf{B}/dt$; $\text{rot}\mathbf{H} = d\mathbf{D}/dt$; with $\mathbf{j} = \mathbf{0}$ in the latter one), by applying the rotor operation on both, along the connection between electric induction and electric field strength ($\mathbf{B} = \mu\mathbf{H}$), and between the magnetic induction and the magnetic field strength ($\mathbf{D} = \mu\mathbf{E}$) to arrive at the same form for the both electromagnetic field components in form

$$c^2(\text{graddiv}\mathbf{E} - \text{rotrot}\mathbf{E}) = \partial^2 \mathbf{E} / \partial t^2 \quad (1.1.4)$$

$$c^2(\text{graddiv}\mathbf{H} - \text{rotrot}\mathbf{H}) = \partial^2 \mathbf{H} / \partial t^2, \quad (1.1.5)$$

in Variant I. Another form, Variant II, has been derived outgoing from the so called Faraday law and its 'dual' form, respectively: $\mathbf{E} = \mathbf{v} \times \mathbf{B}$ and $\mathbf{H} = -\mathbf{v} \times \mathbf{D}$.

$$v^2 \cdot \text{graddiv}\mathbf{E} - c^2 \cdot \text{rotrot}\mathbf{E} = \partial^2 \mathbf{E} / \partial t^2 \quad (1.1.6)$$

$$v^2 \cdot \text{graddiv}\mathbf{H} - c^2 \cdot \text{rotrot}\mathbf{H} = \partial^2 \mathbf{H} / \partial t^2. \quad (1.1.7)$$

Whereas in line with general understanding the second term in left-hand part is supposed to contribute to transversally propagating wave, and the first term to the longitudinally propagating one, the Variant II even predicts different velocities of the two. By strictly sticking to the unconditional validity of the Maxwell's equations, Prof. Bruhn [7] has provided indications of untenability of the related interpretations and incorrectness of certain derivations, ranging from the inability of these systems of equation to be 'satisfied' by the conventional plain-wave solution consisting from an outgoing and an in-going wave (as though this is the only possible wave-solution that meets such an requirement), certain formal inadequacies of applying differentiation rules leading to predefined inter-dependence of position and time, as well as the paradoxical (!) orthogonality of both field vectors with direction of propagation, while one of them should actually be collinear with it, if to propagate longitudinally (related to Variant II), and finally the obvious disappearance of the longitudinal component by the mere non-existence of either electric or magnetic inductions, as $\text{div}\mathbf{D} = 0$; $\text{div}\mathbf{B} = 0$.

Impact of structural constraints

Besides intrinsic limitation of the classical wave equation, in its construction and the form of its solution, (1.1.4) and (1.1.5) involve an additional constraint – direct relationship between the two components of the vector fields, \mathbf{E} and \mathbf{H} . Moreover, these forms are produced in retrofit, assuming $\text{div}\mathbf{D} = 0$ and $\text{div}\mathbf{B} = 0$ under which apply the equations $\Delta\mathbf{E} = \text{graddiv}\mathbf{E} - \text{rotrot}\mathbf{E}$ and $\Delta\mathbf{H} = \text{graddiv}\mathbf{H} - \text{rotrot}\mathbf{H}$. This very well illustrates insurmountable difficulties and inappropriateness of attempting to overcome the rigidity of certain theoretical framework, while still holding it 'sacred'.

However, the Atsukovsky's critical analysis and amelioration of most of the fundamental flaws of Faraday, Maxwell, Heaviside, Gibbs offer basis for overcoming many constraints existing in the currently valid electromagnetics formulation. First of all it is the inherent asymmetry in the first two equations, whereby the two fields are generally different, so that in place of equality between the left- and the right-hand side the 'unilateral' cause-effect relationship applies, (1.9) and (1.10). Although a systematic approach might lead to a more accurate and compelling formulation, presently even in the considered case of just going out from the classical wave equations, the Atsukovsky's analysis and experimental work (at least in the realm of electric induction, i.e. electric field) expressed by (1.12) to (1.13) may justify

(1.1.4) and (1.1.5). Indeed, in case of the explicitly absent electric charge(s), $\rho = 0$, by taking gradient part in of (1.1.4) one gets

$$\text{graddiv}\mathbf{D} = -\frac{\partial\text{grad}\mathbf{D}}{c\partial t}, \quad (1.1.8)$$

while, due to $\text{graddiv} \equiv \text{divgrad} + \text{rotrot}$ for the related part of (1.1.5) follows

$$\text{graddiv}\mathbf{B} = -\frac{\partial\text{grad}\mathbf{B}}{c\partial t} + \text{rotrot}\mathbf{B}. \quad (1.1.9)$$

Moreover, because of presence of scalar divisions of inductions and their propagation velocity vectors, by having, say v in place of c in the above equations, notwithstanding inherent obsolescence and irrelevance of the classically-relativistic transformations between two inertial systems used for arriving at (1.1.6) and (1.1.7), different velocities of longitudinal and transversal waves propagation could be somewhat supported. Again, the asymmetry underlying the (consistent) derivation of these two equations comes from the fact that, considering in terms of the implied Lorentz-ian force(s), in the two equations $\mathbf{E} = \mathbf{v} \times \mathbf{B}$ and $\mathbf{H} = -\mathbf{v} \times \mathbf{D}$ velocities pertain to different aspects of particle charges – electric in the first, and the magnetic in the second one. (The intricacies related to the differentiation rules and the critical reference to in [7] might rather have been addressed to the historical development of electromagnetics, wherein the Hertz’s formulation of electrodynamics with using full instead of partial time-derivatives have made the Maxwell’s equation invariant to the classical Galilean transformations, based on which the Lorentz transformations, L-force and STR become obsolete [12].)

Although contrasting the largely justifiable critic of Meyl’s formulation of the scalar/longitudinal waves equations with the inconsistencies and deficiencies of the classical (and the relativistic, if really needed) electrodynamics would be of interest to be made in the full scope, let here address only one more aspect related directly to constraints imposed by the Faraday’s own inability to figure out the true mechanism of electromagnetic induction coming from the magnetic “lines of forces” truly cutting the conductors’ lines/contours – either in process magnetic flux time-variation or the relative motion (the latter having been the problem by which Einstein kind of was motivated to start with develop the STR ...). Namely, in the 11th question posed to Prof. Meyl, Prof Bruhn (‘On Faraday’s refutation of “hydrotic term” in the induction-law’, in German, [13]) says the following:

“ You have extended the “hydrotic term” \mathbf{H}/τ_2 to

$$(M 27.20) \quad \text{rot}\mathbf{E} = -\mu \left(\frac{\partial\mathbf{H}}{\partial t} - \mathbf{H}/\tau_2 \right)$$

(p. (27.20) in EMV-3: K. Meyl, “Elektromagnetische Umweltverträglichkeit – Teil 3,” 2003; on page 564 in [6]).

Question a) Is it known to you that M. Faraday just before 1830 has proved, that $\mathbf{b} = \mathbf{H}/\tau_2$ (in air) has always to be **Null**?

M. Faraday has long time, as we today would say, searched for the circular electric voltage, i.e. $\text{rot}\mathbf{E} \neq 0$, in a static magnet fields ($\mathbf{H} \neq 0$ und $\frac{\partial\mathbf{H}}{\partial t} = 0$), however in vain, therefore after (M 27.20) the equation $\mathbf{0} = -\mu \left(\frac{\partial\mathbf{H}}{\partial t} - \mathbf{H}/\tau_2 \right)$ (has been) proven, or due to $\mathbf{H} \neq \mathbf{0}$, also $1/\tau_2 = 0$.

Question b) Which experimental findings are there as of today, which could speak for $1/\tau_2 \neq 0$ in air or Vacuum??

Not going into fully defending this particular result, because of the agreed-upon basic inconsistencies of the related derivation, but to encourage to generally take a constructive stance⁴, here it should definitely be worth noting that it had taken Atsukovski exactly six years to establish the fact that even with time-varying magnetic field the induced EMF can turn out to be zero, due to the mutual compensation of contributions of the magnetic field lines falling inside and outside of a closed loop, (1.37), and that on the other hand the curl of the electric field depends on components other than just one of the components in (1.58) may turn out to be such that its time derivative does not vanish, but exhibits certain (time-extended) persistence.

Most recent Meyl’s formulation of the electromagnetism [1] involves the symmetrization based on the preceding identification of magnetic monopoles by physicists of the Helmholtz Institute. Although the objections in line of his Variant II formulation may still apply, the Atsukovsky’s extended EM framework provides certain encouragement and support, notably the “magnetic current density” in (1.58), as well as the analogon of the Faraday’s induction law, (1.38).

⁴ The fervent supporting of the traditionally established principles/postulates/theories of Prof. Bruhn can be found also in regard to the classical mechanics. A critic of this author on his critic-of-the critic regarding the inappropriateness of the simultaneous use of both the energy and the conservation laws can be found at

<https://www.dropbox.com/sh/hm9vil15gz62a65/AABV-nATUuAJESoGAwNEH6MMA?dl=0>

Regarding the connection between increase of the number of conditions and decrease of set of possible solutions

Although the traditional Maxwell's equations do not allow for the scalar, that is the longitudinal waves in media without charges, and/or *in vacuo*, it does not mean that in line with the commonly agreed upon decrease of possible solutions with increase of number of constraints a rather specific, and/or peculiar solutions would result. Indeed, that has turned out to be exactly the case with purely longitudinal waves based on the so-called force-free magnetic field, that is the magnetic vector potential which curl is collinear with itself. Such configuration and the related current distribution has been derived [15], and is outlined here as an example of the varieties of electromagnetic field in overcoming the claims about the traditional Maxwell's equations regarding the unavailability of the scalar, that is longitudinal electromagnetic waves.

Besides the four Maxwell's equations (1.1) to (1.4), with $\mathbf{j} = \mathbf{0}$ (in considered space, of the form to induce a suitable \mathbf{A}),

$$\text{rot}\mathbf{E} = -d\mathbf{B}/dt \quad ; \quad \text{rot}\mathbf{B} = (1/c^2)d\mathbf{E}/dt \quad ; \quad \text{div}\mathbf{E} = 0; \quad 4. \text{div}\mathbf{B} = 0, \quad (1.1.10a)$$

added are two equations which characterize the magnetic vector potential

$$\text{rot}\mathbf{A} = \lambda\mathbf{A} \quad \text{and} \quad \text{div}\mathbf{A} = 0, \quad (1.1.10b)$$

whereby in line with the force-free magnetic field, discovered back in 1952 [16], the to it parallel magnetic vector potential has form

$$\mathbf{A} = \text{rot}(\varphi\mathbf{u}) + (1/\lambda)\text{rotrot}(\varphi\mathbf{u}), \quad (1.1.11)$$

with \mathbf{u} an unit-vector, and the potential $\varphi(\mathbf{r})$ is representing solution of the scalar differential (Helmholtz's) equation⁵

$$\nabla^2\varphi + \lambda^2 \cdot \varphi = 0, \quad (1.1.12)$$

and λ is a constant.

The magnetic and electric fields (\mathbf{E} , \mathbf{B}) defined as $\mathbf{B} = \lambda\mathbf{A}\cos(\omega t)$ and $\mathbf{E} = \omega\mathbf{A}\sin(\omega t)$, with $\omega = \lambda c$, do indeed satisfy (1.1.10a/b). The thus constructed electric and magnetic fields are genuinely Maxwellian self-sustained, "non-Hertzian" longitudinal (and "scalar" at least to the extent of being derived from the scalar potential function) 'oscillation' *in vacuo*. The current density which, in accordance with the conventional techniques, generates such a field then is $\mathbf{j}(\mathbf{r}, t) = \mathbf{J}(\mathbf{r}_b)\cos(\omega t)$, where $\mathbf{J}(\mathbf{r}_b)$ represents current concentrated at distance $r = r_b$ from the central axis of a torus-shaped form on which surface the \mathbf{E} and \mathbf{B} fields' line of forces are situated, intertwining one 'inside' the other, with a limiting curve which is itself a line of force.

It turns out that this particular solution of the traditional Maxwell's equations provides a structure which falls very close to the very Ether-substrate elements, that is its potentiality⁶ in creating such dynamically more-or-less stabile structures, based on conceptualization of which, and some additional features, the very "colossal construction" of Maxwell can and has to be 'ameliorated'. The missing features, or aspects, apparently are the compressibility and viscosity, as per [2], so that with reduced ideal features these elementary structures become capable of mediating propagation of electromagnetic disturbances of generalized form, including both the transversal and longitudinal mechanism.

(Regarding the earlier hinted prospective suitability of the magnetic vector potential as a more general structure then the magnetic induction and/or field strength, by putting it in the classical wave equation

$$c^2(\text{graddiv}\mathbf{A} - \text{rotrot}\mathbf{A}) = \partial^2\mathbf{A}/\partial t^2, \quad (1.1.13)$$

and with accounting for the features given by (1.1.10b), one gets (with and without accounting for the left side of it)

$$c^2(\lambda\mathbf{A}) = \partial^2\mathbf{A}/\partial t^2, \quad \text{and} \quad c^2(\text{divgrad}\mathbf{A}) = \partial^2\mathbf{A}/\partial t^2, \quad (1.1.14a)$$

solution of which may provide something between the two extreme cases – idealistic and realistic – filed configurations.)

⁵ The static (time-invariant) nature of the magnetic vector potential is assumed for 'construction' of this particular EM field structure. A more general approach can be found in [17], where energy aspects of such magnetic field were evaluated as a sum (over the unit sphere) of the two components: energy in 'poloidal' (which may be same as Atsukovsky's ring, i.e. "kolytsevov") and toroidal (again, likely just as the Atsukovsky's one) fields. (Toroidal and poloidal fields correspond to the first and the second parts in (1.1.11).

⁶ Of interest in this context should be an old work showing how vector field can be derived from two potential fields [8].

2. Implications to wireless networks – energy supply and power-efficient communications

From historical perspective, the transmission of energy and information were tightly interrelated. In the early experiments of Gray the mechanical rubbing of a rope was producing the electrostatic attraction on dislocated small objects, and that could have been considered as the first ‘wired’ transmission of information in that the actions at the ‘transmitting’ side were influencing the events on the side of the receiver.

As a matter of fact, the first wireless transmission of energy was coincident with the Galvani’s effect of frog’s legs sudden and intermittent convulsions and jumping around were caused by discharges of the nearby situated electrostatic machine operated on by his assistant. They later extended a wire that was (for some of the originally intended biological research) attached to the fog’s legs, to come up with what can be considered as the first wireless transmission system.

The ever first taping the energy from the environmental electricity was Franklin’s experimentation with the elevated kite, actually a capacitance plate held afloat on a wet rope, at the time of very intense electrostatic discharges in atmosphere.

It took almost a century thereafter, when Mahlon Loomis (1826-1886) flew two kites at distance of about 1.5 km. He hooked-up a telegraph key to one of them and the telegraph sounder to the other – and the system (somehow?!) worked, marking the first truly wireless transmission of information with naturally available and directly taped on energy/power. The modern era of wireless transmission, including Tesla’s wireless energy transmission, did pursue the same concept.

2.1. Wireless Energy transmission

What Tesla subsequently did, he took a several steps forward. Instead of using the available electricity he applied electricity to it. To that process he found that other elevated capacities would be metallic balls elevated on tall insulated masts or buildings, so that one can transmit from such one antenna to the other, and that constitute the first engineerable electrical wireless transmission system through space. The Tesla’s wireless system transmitter starts-up with a can, the EMF generator and the earth-connection. He wanted to light-up a nearby bulb, and since the can was acting as a capacitor, nothing was coming out of the generator. After introducing some inductance, the generator was starting being loaded-up and with looking for the right the expected effect came to be noticeable. With improvements in tuning, the spark-gap was also considered but he ended up with adequate configuration which actually was maximally circulating the energy within the system. Essentially, the low-right configuration, with insertion of the “extra-coil” next to the antenna-capacitor, and inclusion of the flat (pan-cake) transformer, presents the Tesla’s Magnifying Transmitter TMT.

The transmission-reception system has been finding a lot of interest since then, and many researchers have analyzed it. In line with Tesla’s own analogy with the particular form of mechanical oscillator and his own claims, in [18] the authors, based on their in-depth long-time explorations, have concluded that the TMT is essentially a power amplification arrangement which essentially parallels the mechanical lever of Archimedes, and that Tesla’s goal was to produce longitudinal excitation of the Earth (at the earlier stages of his research) and the excitation of the Earth-ionosphere cavity.

In the point-to-point energy supply, Tesla conceived a distribution system relying on standing and traveling waves.

The long-time “Teslianer”, Eric Dollard⁷ (<http://ericpdollard.com>), explains that “the transformer itself is a monopolar device that has only one terminal which is the neutral which connects to Earth, and the other terminal is “dead-end”, that is the space-capacitance is decoupled as much as possible from the surface of the Earth, and it is a point of reflection of the electrical system, and the electrical field around it is the dielectric field ... and by no means is a part of the transmission process, except accidentally.”

A quite appealing interpretation can be found in the internet at <http://amasci.com/tesla/tmistk.html>, where it has been found that “in Tesla’s energy transmission system it goes about a one-wire⁸ system, in that the longitudinal perturbations (sloshing of earths electrons/ions back and for) while, over the earth, due to the presence of atmosphere and ionosphere, the conventional Hertz-ian, that is transversal electromagnetic propagation takes place. In a way, Tesla was using the ground as a transmission line and he was correct in insisting that he was producing longitudinal waves in the “natural medium.” He was correct in saying that the ground was not just a voltage reference. In this case the “natural medium” is

⁷ From his Energy Conference 2014 presentation “The extra-luminal transmission of Tesla and Alexanderson,” (<http://ericpdollard.com>); all the illustrations in this section thus far have been borrowed from that presentation.

⁸ What is known as Tesla’s explicitly one-wire transmission system is related to tying the non-earthed ends of the output- and input-coil (at the Tx and Rx sides, respectively) by disproportionately thinner wire than it would be needed for the conventional energy transmission (US Patent 593,138 of 1879), the wire having been coated by segments of insulator material (driving available only in the Tesla’s Museum in Belgrade?!). This may fall closer to the scalar waves propagation in Ether, which for logistical and practical reasons would be of interest for the future energy transmissions, or at least efficient communications.

the population of mobile ions in the dirt and oceans which cause the Earth act as a conductor “. It should be noted that the ball-shaped capacitors still plays the role of virtual ‘earthing’, and that have no role as the radiating elements.

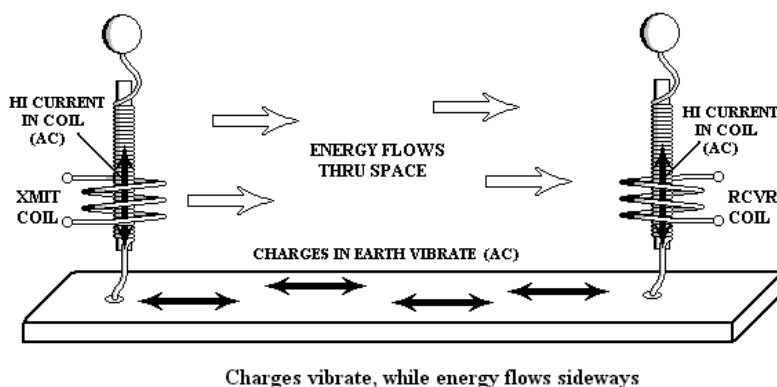

Since for this, one can freely say a very ambitious goal, big currents have to be utilized and that might have been the reason that Tesla had done most of efforts to provide proper earth-connection, along the other very challenging issues. For the “small-size” configurations, that still should be an important disadvantage, and the only successful replication seems to have been done by Eric Dollard (<http://ericpdollard.com>), whereby the sea-water was available for the ‘grounding’, and the separation between the transmitter and the receiver were up to several kilometers..

For much smaller distances on the order of several meters, during last two decades there have been available the scalar waves experimental set-up designed and procured by Prof. Meyl (<http://www.k-meyl.de>).



There have been an extensive set of experimental results collected in the book [14] witnessing the operation in terms of energy transmission, and also several very critical reports. In addition, the strongest objections have come from Prof. Bruhn [13] and some other experimenters, notably <http://www.xy44.de/skalar/> and some other links indicated therein.

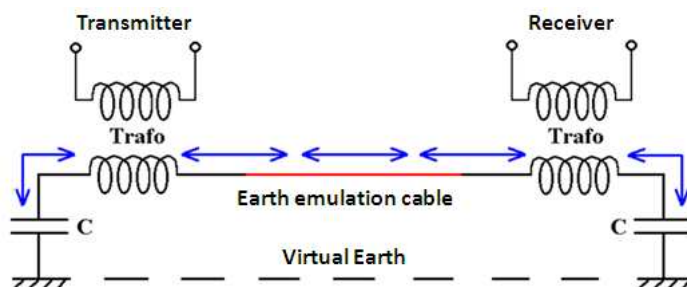

The main objections are that the system represents nothing more than a double-circuit band-pass filter with capacitive coupling and that functioning of the equipment under Faraday-like shielding of the transmitting part of the equipment does not confirm the presence of scalar waves, because the actual transmission proceeds over the wire cable which plays the role of Tesla's earth contact. In addition, since the operation is not possible with using standard earth connections in buildings, as available in power supply doses, heating and water supply pipes, etc., the similarity with the true Tesla's set-up has been denied. In the light of the evaluation of the original Tesla's energy transmission concept, the question then arises if the entire transmission may have been done through the Earth only.

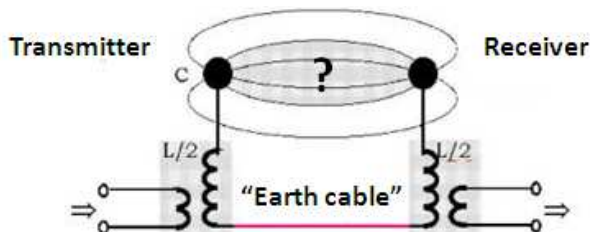

Because of the proximity of transmitter and receiver, it looks that the near field effects are taking place, and that is the only mechanism that has been under consideration in the realm of conventional electromagnetics [19][20][21][22], with the main goal towards extending the near-field range to as wider as possible. Although the near field phenomena may have be related to scalar, i.e. longitudinal propagation, what should be of interest for communications and possibly to energy transmission purpose should be their propagation at relatively longer distances.

2.2. Wireless communications

The first experimental proof of validity Maxwell's equations performed by Hertz by the end of 19th century actually was the first arrangement which has been fully detached the surface of Earth. However, since the transmitter and receiver were in near proximity of each other, it might have happened that besides the targeted transversal waves present were also the longitudinal, i.e. the scalar ones.

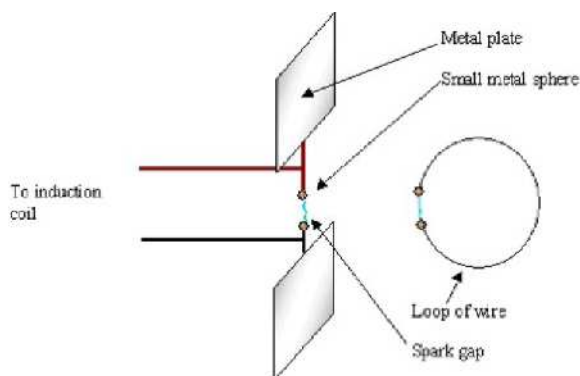

Interestingly, in the developments that ensued as of today there has been only the vertically oriented dipole elements on both the transmission and reception sides having been exploited in practice. The proof for mere presence of transversal wave is usually supported by the fact that vertically oriented dipole at the transmitter and horizontally oriented at the receiver sites do not result in a perceivable effect.

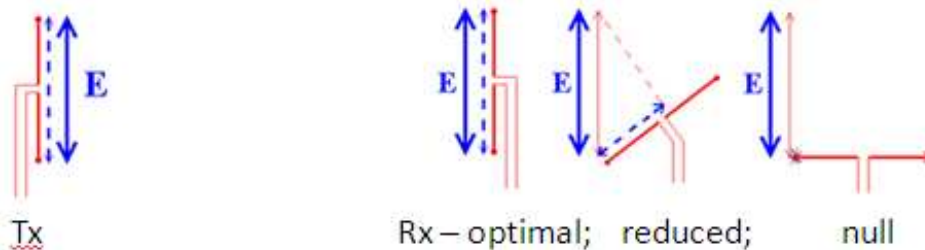

However, if taking collinearly situated dipoles at the transmitter and receiver sides, the situation can be the opposite, especially, in line with the second (scalar) field of Kolya Sibirsky, that is considering the 'linear' magnetic field and its longitudinal propagation, which more and more has been receiving recognition in domain of electromagnetism of biological systems and in differentiation between paramagnetic and diamagnetic features of materials:

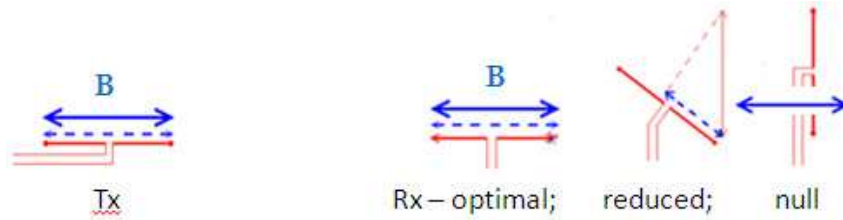

Indeed, the analysis, identification and implementation of the longitudinally propagating electric field with a half-wavelength dipole with concentrated parameters, that is two balls being excited in counter-phase by an AC source, although conducted for the semiconducting medium (see-water) can be quite instructive. In [2] it has been shown that energy propagation (Poynting) vector is both perpendicular to and collinear with the dipole axis

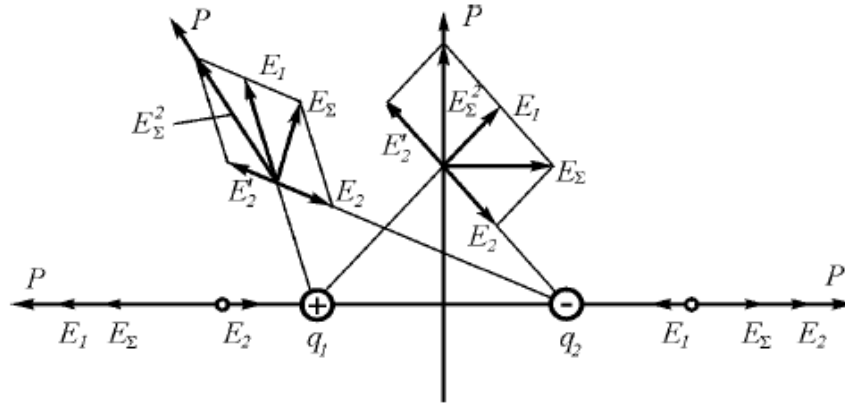

and the radiation pater is much more pronounced in the direction of dipole axis then in the ‘traditional’ transversal one.

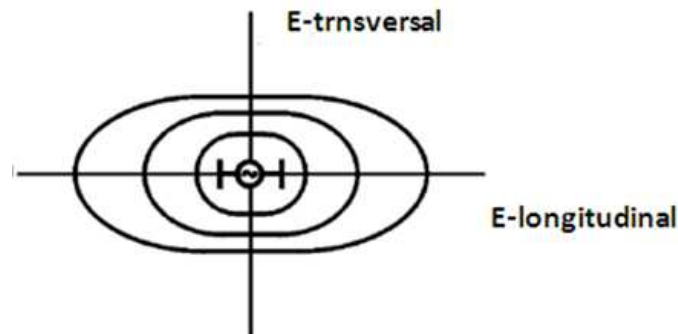

At this point it becomes perfectly suitable to relate to the previous analysis of formal analytical support of scalar waves propagation by referring to an earlier work⁹ on analysis and implications of the Aharonov-Bohm prediction and experiment, that is the influence of electromagnet in form of a long solenoid (without detectable magnetic field outside of it) on interference of two electrons passing the same length trajectories around it. By taking the expressions of the electric and magnetic fields vectors based on potential $\mathbf{E} = -\text{grad}\Phi - (1/c)(\partial\mathbf{A}/\partial t)$ and $\mathbf{B} = \text{rot}\mathbf{A}$ into (1.1) to (1.4) with $\text{div}\mathbf{E} = 4\pi e$, along with the Lorenz gauge condition $\text{div}\mathbf{A} = -(1/c)(\partial\Phi/\partial t)$, for quasi-static conditions of the Aharonov-Bohm’s experiment or if the generating source enforces the magnetic field to be zero, the zero then becomes also the electric field, with $\mathbf{A} = \text{grad}\mathfrak{N}$ and $\Phi = -(1/c)(\partial\mathfrak{N}/\partial t)$, the entirely scalar wave equation $\nabla^2\mathfrak{N} - (1/c^2)(\partial^2\mathfrak{N}/\partial t^2) = 0$ is arrived at. This thus predicts the existence of scalar waves, which actually replace the potential waves when the \mathbf{E} and \mathbf{B} fields are zero. The scalar fields are more primitive than the potential fields, in that the latter are derived from the former. If \mathfrak{N} varies harmonically with time, then $\mathbf{A} = i \cdot \mathbf{k} \cdot \mathfrak{N}$, where \mathbf{k} is the wave vector which is pointing in the direction of travel. It is seen that waves of \mathbf{A} , in absence of electric and magnetic fields, are purely longitudinal in that the \mathbf{A} vector points into direction of travel. (This speaks again a lot in support of the possibility to support longitudinal modes not only in plasma and or media with free charges, but also in the vacuum, that is in the Ether.)

⁹ Y.Y. Dea, “Scalar fields: their prediction from the classical electromagnetism and interpretation from quantum mechanics,” at the Tesla ‘84, Proceedings of the Tesla Centennial Symposium “Light in Modern Physics”, Colorado College, International Tesla Society, Inc. 1995, pp.94-98.

In the case of radiation from an oscillating dipole, the vector potential field is $A \approx \sin[\omega(t-r/c)]/r$ and in the radiation zone ($r \gg \lambda$) $A \approx \cos[\omega(t-r/c)]/r$ and $A \approx \cos[\omega(t-r/c)]/r$. The energy received at the receiving antenna is $S \approx E \cdot B \approx 1/r^2$. The scalar phase parameter, \mathfrak{K} , also appears to have a $1/r$ dependence: $\mathfrak{K} \approx \cos[\omega(t-r/c)]/r$. Thus it is seen that in detecting \mathfrak{K} - fields a $1/r$ drop in intensity will be observed, while in detecting (Hertz-ian, transversal) radio waves a $1/r^2$ drop in intensity will be observed. Furthermore, it is also of interest that the A fields when decoupled from E - and B -fields, become \mathfrak{K} -fields which penetrate all objects because there will be no energy transfer to objects when E and B are zero. However, if A interacts slightly with highly non-linear media, or if A has a weak coupling with B and E , then it is possible that A can be rotated enough such that $B = \text{rot}A \neq 0$. In such situations, scalar fields may be detected using highly non-linear or meta-stable systems.

This in turn leads to the importance of considering both the transmission/modulation and reception/demodulation modalities to truly manifest and make use of the scalar/longitudinal waves. Although there have been a number of patents granted for transceiver designs based on the curl-free (rotor-less) magnetic vector potential [23] (along with some patents related to distance and angles measurements for localization, being referenced therein, which again is of big importance for the modern (tele)communications paradigm of integration of communications and navigation functions), full reliance on the extensions of Maxwell's equations might still be needed, and at least accompanying/complementing approaches as are these, in particular regarding the overcoming of the "retarded potential(s)" problem. When it comes to application of various toroidally-formed antennas [24], including those known as Rodin-coils and Möbius strip/coil¹⁰, the Tesla's transceiver system with the Tx-secondary and Rx-primary planar-winded coils comes to think of as radiating and radiation absorbing elements.

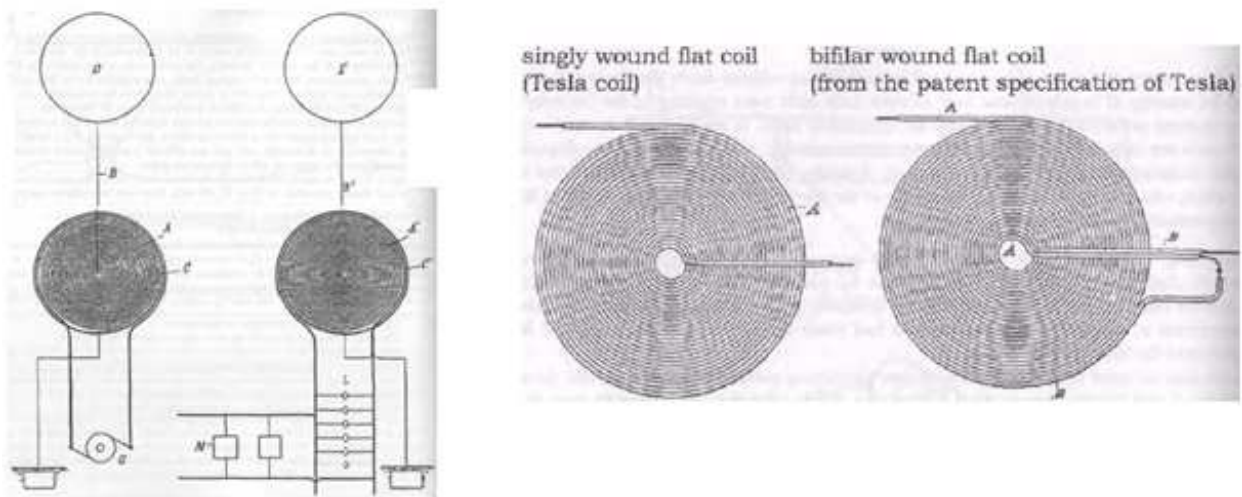

It might be quite intriguing that this particular configuration did not find an interest in being replicated, and on the other hand, as mentioned before, the bifilarly wound coil re-formed in a half-dome shape behaves as the magnetic monopole.

2.3. Synergetic approach – link and networking levels

For the near-future wireless communications reduction in link level attenuation from one-over-distance-squared to just one-over-distance would in principle mean doubled network coverage or halved transmitter power for same network size, or combination thereof. Having in mind the detrimental effect of inter- and intra-cells interference for the overall network performance, the reduction in the all-out emitted energy should be of prime importance, though.

Besides the intrinsic directionality features that the link-level communication based on longitudinal "magneto-electricism" could bring with itself in the currently deployed and being developed MIMO systems regarding the overcoming of still interference-limited network performance, on the link-level the prospectively efficient full-duplex transmission could likely be relieved, at least from the traditionally present hindrance to introduction of this technique in the wireless realm and which is related to a very high ratio of the received and the (locally) transmitted signals' strengths.

Interference alignment and cancellation are one of the most challenging aspects of the advanced wireless communications systems design and deployment, and they become even more pronounced in case of generally non-LoS backhauling links immersed in the "sea" access points and user terminals communicating in combination of contention and non-contention based access modes, the impact of which has to be taken along the link-level self-interference :

¹⁰ Many more, including also some particular scalar-waves based transceivers, as Prof. Seike's one, can be found in [6].

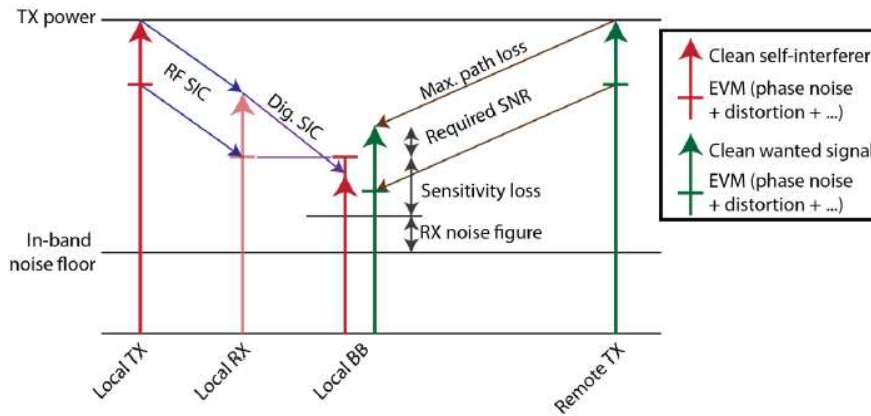

Degradation of the receiver sensitivity due to the EVM-content of the self-interferer.

The rather ambitious attempt to arrive at a maximally optimized duplexer has been primarily motivated by the need to avoid impact of phase noise through enabling the explicit echo cancellation to take place at least at relatively low intermediate frequency or even in the base-band, after the (affordably high-precision) analogue-to-digital-converter (ADC). Since the non-linearly distorted component of the transmitted signal is generally much lower from its linear part, the cancellation of its contribution to the Tx-to-Rx leaked signal can be done within the digital signal processing (DSP) functionality, once it has been ensured that the overall self-interference signal is not saturating the RF front-end circuitry, consisting of the LNA (low-noise amplifier), and subsequent mixing and filtering stages. The increase in the power efficiency of the relatively large peak-to-average-power-ratio (PAPR) amplification through the so-called envelope tracking (ET) method is accompanied by introduction of peculiar kinds of non-linear distortions, so that it becomes desirable to maximally avoid or at least reduce the need for it, also for reason of insufficient DC-to-DC converter bandwidths.

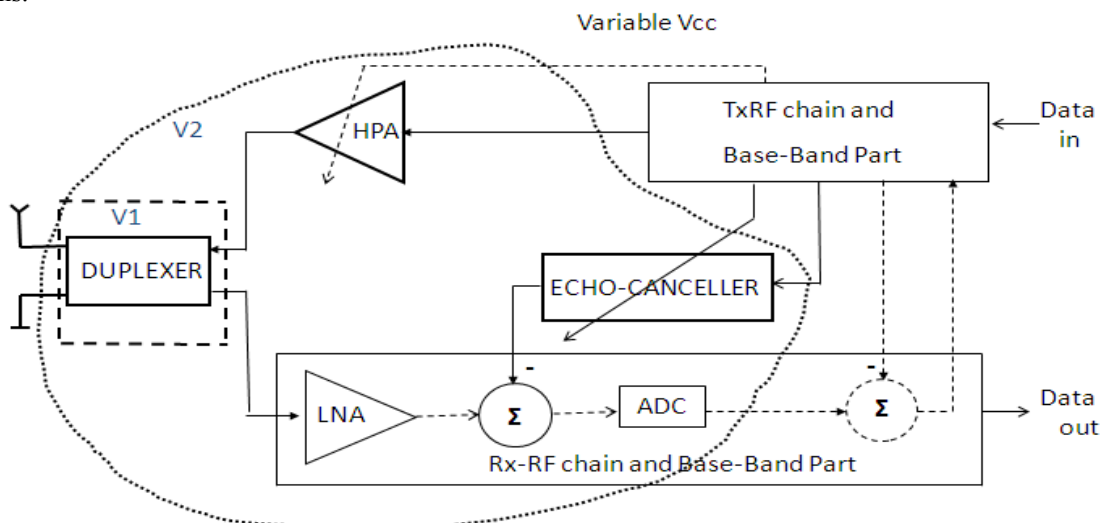

Block-diagram of the targeted configuration of the RF and the BB processing based duplexing. V1 and V2 denote, respectively, the duplexer block for the “electromagnetic” transmitter (Tx) to receiver (Rx) leakage suppression, and the combined with the explicit, preferably digital signal processing means.

Besides the (self) cross-talk signal which has known structure and form, the most challenging impairment is so-called transmitter noise, whose nature might likely have some structuring as scalar waves, rendering a possibility to be coped with by base-band signal processing means, and thus significantly reducing the burden on the RF front-end.

The transmitter noise issue appears to not have been properly addressed in particular in the context of full-duplexing, or implies quite large implementation and/or procedural complexities [25]. While being well below the useful signal level, thus becoming only a tiny part of the far-end receiver noise, through the leakage over the duplexer into the (near-end) receiver chain, it becomes comparable to the receiver noise at even at about 50 dB of transmit link attenuation, and has to be suppressed to well below the receiver noise floor. Out of the whole scope of the scalar waves related electromagnetics paradigm, besides direct advantages of likely allowing for the significantly reduced difference between the transmitted and the locally received radio signals, the utilization of the likely Tx-noise structuring would be also important. In the context of magnetic vector potential based transceivers, the very topological aspects could also bring in new possibilities of the duplexer design.

As for the overall wireless network design, for the facilitation of cost-effective (acceptable Return-of-Investments in networks deployments) coverage extensions and overall throughput increase based on densification of the base-stations infrastructure and their connections to the network back-bone infrastructure), the concept of the so-called Small Cells has emerged recently, based on back-haul relaying, where actually most of the advantages of the full-duplex is to be expected [26][27].

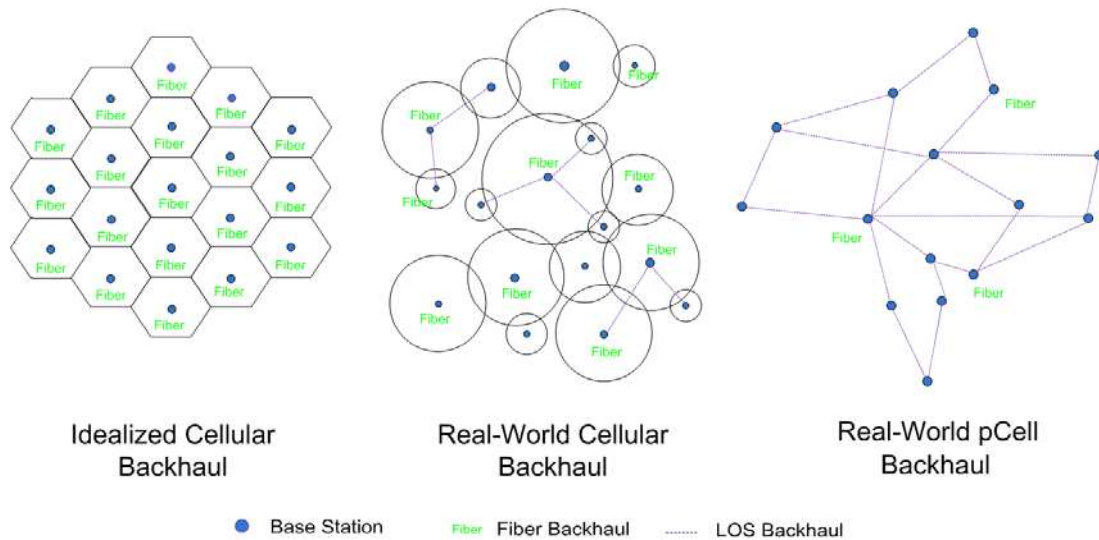

Illustration of the idealistically structured cellular access and the realistic situation: instead of having every small-cell directly connected to the high data transmission capacity links, notably optical fiber based ones, most of the progressively deployed cellular access points have to be supported wirelessly.

While for the conceivable role of mobile terminals as relaying stations the remote power supply would be relevant, for the near-future applications that could be considered only for the stationary transceiver arrangements. In such case, if the utilization of ground connection would really be feasible, in line with Tesla's wireless energy transmission of some upgrading/improving on it, the currently practiced line-of-site (LoS) transmission of information (with highly directive antennas) might to certain extent support even the partial energy transport through the 'air'. Such approach appear applicable for power supply in sensors networks, in particular in situations where the 'senseivers' (combinations of transceivers and sensors) are being spread over the earth or in water, when grounding would possibly be easily feasible. If the power supply would involve the 'progressive standing waves', the communications protocols would be duly adjusted so that the communication proceeds only with set of transceivers which at certain time-interval get 'flooded' by the wave.

While for the general case of remote power supply of the hand-held, mobile terminals one could think of combining two different modes of transmission, for example vertically oriented dipoles for energy transfer, and the horizontally positioned ones for the communications purpose, the issues of environmental safety would definitely be raised. Besides possible generally reduced energy/power levels needed for operation of the future advanced transceivers, in the process of selection of the acceptable energy-transmission/communications mechanism, the compatibility with biological systems would be most important. Based on the current state-of-the-art in various domains – from physics to biology – the linear magnetism appears to be promising.

2.4. Energy harnessing and distributed (localized and self-sustained) energy generation

In line with the expectations that the scalar/longitudinal magneto-electrical 'waves' propagation can rely on the very potential structuring of the Ether itself, the availability of quite intensive man-made 'vortices' in the environment where manifold of wireless communication and broadcasting processes are taking place, including the vicinity of the utility power supply lines, the claims of the produced such effects, notably in [14] might have some credentials and deserve due attention.

Having in mind the electromagnetic compatibility issues that would be even more pronounced when it comes to joint energy transmission and communications practices, as well as because long attempted production of energy from the Ether itself¹¹, the most promising option would be the localized and self-sustained energy generation. Indeed, in relation to Tesla's MT configurations with the spark-gap, his patents on superconductivity effects, and the claimed importance of precise and short-time excitation of the system, the commonly known and widely used Induction Coil can be taken a closer look at.

¹¹ Most of them have been addressed in [6]. For author of this article, among many such, currently of most interest is the work in [28].

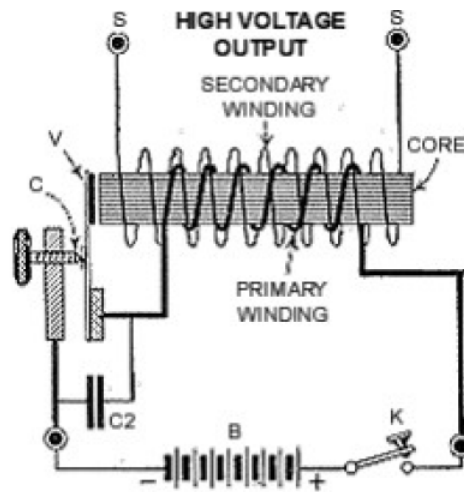

A typical form of induction coil showing diagram of connections, vibrator, core, battery, condenser, and key.

The Faraday's EMF amplification has been finding application in many diverse areas – from electrostatic generator to ignition coil for the internal combustion engines. After the core is highly magnetized by the current flowing through the relatively small number of primary coil windings (contact K closed), by interrupting the primary circuit (contact C opens) the stored magnetic energy that had been created in the open space tends to get back from the area where it was generated by the primary coil current, generating a high voltage at the open ends of the secondary coil in proportion with several orders of magnitude higher number of the windings compared to the primary coil.

While due to anyway large amount of the energy consumed in the equipment as the whole not account have been made of the ratio of the released and invested energy in this process, if it might be higher than one then it could be recycled and kept within system itself. One such configuration has been evaluated in the context of water heater in [29].

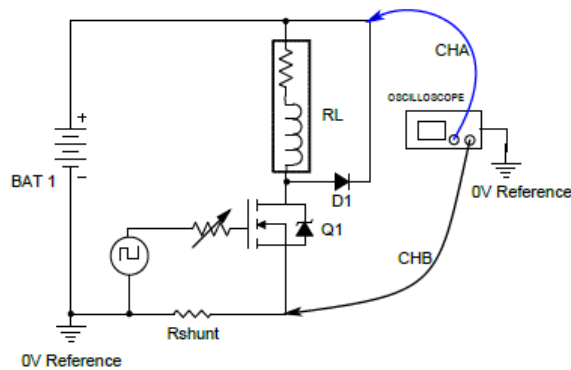

The pulse generator in combination the N-channel MOSFET switch creates shot pulses into the resistive inductor (a ceramic hollow core wire wound). The high gradient generated of the induced magnetic field tends induces the current in the reverse direction after the current excitation ceases, and further passed through the supply battery for its recharging. In [30] the energy efficiency factor was estimated to about 500% in [30].

3. Conclusions

The first part of the paper has provided a wide enough and compelling body of evidence on feasibility of longitudinal electromagnetism within the classical Maxwellian formulation, as well as in the context of its extensions. The etherodynamical support for these extension has indicated that the usually considered magnetic vector potential as quantity useful only for analytical calculations actually has a physical meaning as measure of movement of structuring ethereal substrate. Existence of longitudinal i.e. scalar electromagnetic waves is indirectly supported by measurements.

By the provided overview of the old and recent developments, and the theoretical and practical foundations which go in support of and in a way surpasses the Tesla's old ideas and assertions, this paper is supposed to provide a basis and motivation for making efforts within the radio science and engineering community towards fulfilling to goals of both providing energy efficient communications means, as well to once again entitle human beings to get 'fire in their 'caves'.

R.P. Feynman, The power (and communications) networks of the future may have little resemblance to those of today.

Citations

- [1] K. Meyl, "Self-consistent Electrodynamics," PIRS Proceedings, Moscow, Russia, Aug. 19-23, 2012; also: http://www.meyl.eu/go/index.php?dir=30_Books&page=15&sublevel=1
- [2] V.A. Atsukovsky, "Ethero-dynamical Foundations of Electromagnetism – Theory, Experiments, Introduction," in Russian – original title "Efirodinamicheskie Osnovy Elektromagnetizma – Teoria, Eksperimenty, Vedrenie", 2nd ed., Moskau: Energoatomizdat, 2011, ISBN 978-5-283-03317-4; in Russian - an English translation of the Section 6 'Electromagnetic field' is available on request from the author of this paper at nedic.slbdn@gmail.com
- [3] G.V. Nikolaev, "Non-Contradictory Electrodynamics – Theory, Experiments, Paradoxes," in Russian – original title "Neprotivorechivaya_elektrodinamika – Teoriya, Eksperimenty, Paradoksy," Tomsk Polytechnical University, 1997; English translation is available at http://www.doverchiv.narod.ru/Nikolaev/Nikolaev_modern_electrodynamics.htm
- [4] F. Meno, "A Planck-Length Atomistic Kinetic Model of Physical Reality," Physics Essays, Vol. 4, No.1, 1991; a further elaboration and explication of the underlying elementary gyroscopic mechanics/dynamics has been provided by Harold Kyriazy in "A Viable, Atomistic, Kinetic, Unified Aether Theory," available at <http://vixra.org/pdf/1311.0060v4.pdf> or by request to the author at htk@pitt.edu.
- [5] E. Kelly, "Maxwell's Equations and Shear Waves in the Vortex Sponge," Zeitschrift fuer Naturforschung 45a, pp.1367-1377, 1990.
- [6] K. Meyl, "Scalar Waves", INDEL GmbH Verlagsabteilung, Villingen-Schwenningen 1996-2003, ISBN 3-9802 542-4-0 ; also : http://www.meyl.eu/go/index.php?dir=30_Books&page=6&sublevel=1
- [7] G.W. Bruhn, "On the Existence of K. Meyl's Scalar Waves, Journal of Scientific Exploration, " Vol.15, No. 2, pp.206-210, 2001 ; also available on request from the author at : bruhn@mathematik.tu-darmstadt.de
Numerous articles with critics of Meyl's scalar waves electromagnetics framework derivations can be found at <http://www.mathematik.tu-darmstadt.de/~bruhn/Meyliana.html>
- [8] E.T. Whittaker, "On an Expression of the Electromagnetic Field Due to Electrons by Means of Two Scalar Functions," Proceedings of the London Mathematical Society, Series 2, Vol. 1, 1904, pp.367-732.
- [9] G.V. Nikolaev, "Substantiation of real existence of axial magnetic field of moving charge," in Russian – original title "Obosnovanie realnosti sudhestvovaniya aksiyalnogo magnitnogo polya dvizushegosya zaryada," Red. Zurn. "Izv. vyuzov. Fizika". - Tomsk, 1979. – Dep. V VINITI, per. № 528-79.
- [10] M. Daibo et al., "Vector-Potential Transformer with a Superconducting Secondary Coil and Superconducting Magnetic Shield," EUCAS2015, 1A-LS-P-02; also paper at <http://dx.doi.org/10.1109/TMAG.2015.2436439>
- [11] V.A. Atsukovsky, "General Etherodynamics," in Russian, origan title: "Obshaya Ephirodinamika," 4th Edition, IP Radio Soft 2016.
- [12] T. Phipps, "On Hertz's Invariant Form of Maxwell's Equations," Physics Essays 6 /2 , 1993, pp. 249-256, <http://dx.doi.org/10.4006/1.3029059>
- [13] G.W. Bruhn, "Thirteen Questions to Prof. Meyl," <http://www.mathematik.tu-darmstadt.de/~bruhn/Zwoelf-Fragen.htm>
- [14] K. Meyl, "Documentation on Scalar Wave Technology – for the Transmission od Scalar Waves using the Experimental-kit," Villingen-Schwenningen INDEL: GmbH Verlg Abteilung, 2014; Original edition in German, 2010.
- [15] R.W. Bass, "Self-sustained Longitudinal Waves," in the book "Harnessing the Wheel of Nature – Tesla's Science of Energy," edited by T. Valone, published by www.adventuresunlimitedpress.com, 2002, ISBN 1-931882-04-5, pp. 187-191; firstly presented at the Tesla '84, Proceedings of the Tela Centennial Symposium "Light in Modern Physics", Colorado College, International Tesla Society, Inc. 1995, pp. 89-90.
- [16] R. Lüst and A. Schluter, "Axial symmetrische magnetohydrodynamische Gleichgewichtskonfigurationen," Zeitschrift für Nturforschung, 12a, 1957, pp. 850-854; also: 1954, Zs. f. Ap., 34, 263 (!!?).
- [17] S. Chandrasekhar and P.C. Kendall, "On force-free magnetic fields," American Astronomical Society, vol. 126, p.457,1957.

- [18] K.L. Corum and J. Korum, "Tesla & the Magnifying Transmitter – A popular study for Engineers," in the book "Harnessing the Wheel of Nature – Tesla's Science of Energy," edited by T. Valone, published by www.adventuresunlimitedpress.com, 2002, ISBN 1-931882-04-5, pp. 193-217.
- [19] K. Meyl, "Wireless power transmission by enlarging the near field calculation of the transition from far to near field," PIERS 2015, Prague, Czech Republic.
- [20] M. Haridim, "A high efficiency WPT system using helix antennas," PIERS 2015.
- [21] A. Carvalho et al., "5.8 GHz microstrip antennas and arrays for microwave power transfer," EuCAP 2015.
- [22] B. Zhu et al., "Review of magnetic coupling resonance wireless energy transmission," International journal of u- and e- Service, Science and Technology, Vol. 8, No.3 (2015), pp.257-272.
- [23] R.C. Gelinis, "Apparatus and method for transfer of information by means of curl-free magnetic vector potential," US Patent 4,432,098; also 4,429,280 and 4,447,779.
- [24] J.F. Corum, "Toroidal antenna," US Patent 4,622,558.
- [25] Y. Hua, et al., "Breaking the barrier of transmission noise in full-duplex radio," in Military Communications Conference, *MILCOM 2013-2013 IEEE*. IEEE, 2013, pp. 1558–1563. [Online]. Available: http://ieeexplore.ieee.org/xpls/abs_all.jsp?arnumber=6735845
- [26] I. Harjula, R. Wichman, K. Pajukoski, E. Lahetkangas, E. Tiirola, and O. Tirkkonen, "Full duplex relaying for local area," in Personal Indoor and Mobile Radio Communications (PIMRC), 2013 IEEE 24th International Symposium on. IEEE, 2013, pp. 2684–2688. [Online]. Available: http://ieeexplore.ieee.org/xpls/abs_all.jsp?arnumber=6666602
- [27] O. Taghizadeh and R. Mathar, "Robust multi-user decode-and-forward relaying with full-duplex operation," in *Wireless Communications Systems (ISWCS), 2014 11th International Symposium on*. IEEE, 2014, pp. 530–536. [Online] Available: http://ieeexplore.ieee.org/xpls/abs_all.jsp?arnumber=6933411
- [28] J.W. Newman, "The Energy Machine of Joseph Newman," written and published by the author, edited by E.R. Soule, Jr., New Orleans, Louisiana, 1984, available at <http://www.free-energy-info.com/Newman1.pdf> and <http://www.free-energy-info.com/Newman2.pdf>
- [29] R. Ainslie and D. Martin, "Counter electromotive force enables overunity results in electric systems," http://www.free-energy.ws/pdf/electric_heater_experiment.pdf
- [30] Overunity Heater, <http://www.panaceatech.org/Rosemary%20Ainslie%20COP17%20Heater%20Technology.pdf>

Appendix - translation of the central part of Section 6 in [2]

The first Maxwell's equations express the fact that if within a closed contour/circuit the magnetic flux is changing, in the same circuit an EMF is generated. In a particular configuration, for example if the loop lies in the x-y plane, the magnetic induction has the direction of the z-axis, perpendicular to the x-y plane by applying (1.1) and (1.5) one gets¹²:

$$e_{xy} = -\mu S dH_z / dt \quad (\text{A.16})$$

where S is the area of the contour.

1) The provided equation implies the possibility to change the magnetic intensity along the z-axis without any transverse movement of the magnetic field strength in space. However, it should be noted that this process in nature does not exist. The actual changes in the magnetic field can only be achieved by thickening the lines of force and procuring them to the contour from its (out-)sides (Fig. A.1).

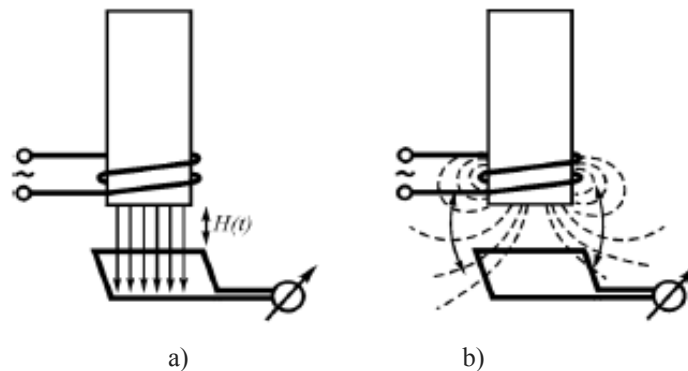

Fig. A.1. Induction of the EMF in the circuit: a — by Maxwell; b — in reality.

Thus the EMF in the loop is not due to changes in the magnetic field inside the contour, but due to the crossing of the conductors contour by the magnetic lines of force, being added to those which already are inside the contour. In that way, since the real mechanism of occurrence of EMF in the circuit is other than the one predicted by the Maxwell's equation, consequently somewhat different should also be the very equation describing this process. The main thing is that in the Maxwell's first equation the process of the magnetic field lines crossing the conductor circuit is not described.

2) The First Maxwell's equation describes the process in the plane, but not in a volume. The intrinsic change of H_z strength along the z-axis is not accounted for. The very slanting of the same plane in the coordinate axes, when both the left and right sides of the equation include all of the three Cartesian coordinates, does not change the essence of this fact.

Still, the first Maxwell's equation and from it resulting integral Faraday's law of magnetic induction allow calculations of transformers and many other magnetic systems, because a formula-based description of the change of the magnetic field inside the loop as the consequence of adding-in magnetic strength-lines from the sides of the circuit is numerically almost identical with the mathematical expression of the First of Maxwell's equation, and that in most cases allows, by ignoring the essence of the process, the necessary calculations with satisfactory accuracy. However, sometimes deviations in the calculations exceed the permissible error quite considerably.

3) In the equation the right- and the left-hand sides are not equivalent. The right part of the equation is the cause and the left side is its consequence. If by changing magnetic induction with a constant rate one can create in the contour a constant EMF, the reverse action cannot be effectuated, because by creating in the circuit a constant EMF no permanent(ly) chang(e/ing) (of) the magnetic induction can be obtained. It therefore would be correct to put instead of equality the sign " \Leftarrow ", indicating that the left part is a consequence of the right one:

$$\text{rot}\mathbf{E} \Leftarrow -d\mathbf{B} / dt \quad (\text{A.17})$$

and the same applies to the integral form

¹² In referring to these two equations, instead of (6.1) and (6.5), as corresponds to the Section 6 in the book, used is (1.1) and (1.6), referring to the equations in the main body of this article; in order to provide correspondence to the original text, the numbers after ' \cdot ' are retained same. This also applies for the numbers of figures.

$$e = \oint_l \mathbf{E} \cdot d\mathbf{l} \Leftarrow -d\Phi_M / dt \quad (\text{A.18})$$

It follows to be noted that in nature the ways to reverse the cause and the effect do not exist; for example, if passing in the conductors of the circuit constant current, one can create a magnetic flux, but the inverse operation is impossible: it is not possible to produce in a (conducting) contour a EMF by creating within the contour of a constant magnetic flux.

The second Maxwell's equations expresses the fact that if in a conductor flows a current, then around it arises a magnetic field, the value of which can be determined.

Principally, the Maxwell's second equation can be separated into two parts:

$$\text{rot}\mathbf{H}' = \mathbf{j} \quad (\text{A.21}) \qquad \text{rot}\mathbf{H}'' = d\mathbf{D} / dt \quad (\text{A.22})$$

Its integral form – the law of total current – reflects only the first part and for the second part the analogous form is absent, although it also can be written, in the form

$$\oint_l \mathbf{H} \cdot d\mathbf{l} = \mathbf{S} \cdot d\mathbf{D} / dt \quad (\text{A.23})$$

Unlike the first one, the second equation of Maxwell and the law of total current realistically reflect/express the occurrence of the magnetic field around the conductor. However, one can provide certain objections here as well.

1) The law of total current is analogous to the law of the constancy/conservation of the circulation for the vortex motion of the non-viscos and incompressible fluid:

$$\oint_l \mathbf{v} \cdot d\mathbf{l} = \Gamma \quad (\text{A.24})$$

where \mathbf{v} is the fluid velocity around the center of the vortex and Γ is the intensity/strength of the vortex. This law reflects the vortex statics, A.e. the fluid motion in an established (steady-state) vortex. Consequently, both the law of total current and the second equation of Maxwell reflect the static magnetic field, and at all not the dynamical(ly) (changing) one.

2) Since in the second Maxwell's equation and the law of total current absent are whatever changes of the processes in time, so for example, if the value of a current is changed, in accordance with the equation of law of a total current the value of strength/tension

$$\mathbf{H} = \mathbf{i} / 2\pi R \quad (\text{A.25})$$

has to change instantaneously, irrespectively of the separation of the line force from the current carrying conductor. No retardation (delay) whatsoever is provided by the equation, what contradicts the reason since there has to be a delaying of an effect (strength of magnetic field) with respect to its cause (current).

3) The Second Maxwell's equation, like the first one, describes the process in a plane, but not in a volume. The actual changing of \mathbf{E} strength along its direction is missing therein. And also, as in the case of the first equation, the very slanting of the same plane in the coordinate axes, when both the left and right sides of the equation include all of the three Cartesian coordinates, does not change the matter of this fact.

4) In the second Maxwell's equation, as in the first one, the right- and the left-hand parts are not really equivalent. Here also the right part of the equation is the cause and the left side is a consequence of it. If by changing the electric induction with a constant rate or by passing a direct current through the conductor one can create a magnetic field in the vicinity of the conductor, the reverse action cannot be effectuated, since by establishing in the vicinity of the conductor a permanent magnetic field no permanent change of electric induction or direct current in the conductor can be obtained. Therefore between the right and left parts of the equation instead of equality has to be placed the sign " \Leftarrow ", indicating that the left part is a consequence of the right one:

$$\text{rot}\mathbf{H} \Leftarrow \mathbf{j} + d\mathbf{D} / dt \quad (\text{A.26})$$

and also to it corresponding integral equation (the total current law)

$$i = dq / dt \Rightarrow \oint_l \mathbf{H} \cdot d\mathbf{l} \quad (\text{A.27})$$

The third equation of Maxwell is also deficient: therein exists no time factor, therefore those are the equations of statics.

Indeed, if the Ostrogradsky-Gauss divergence theorem in the textbooks is usually placed in the section of electrostatics, then there is no justification for the differential expression of the very same — the third equation of Maxwell in those same textbooks to be placed in the sections of dynamics. That the integral form is actually a static form is easy to be seen from the circumstance that from that expression derived electric displacement

$$D = q / 4\pi R^2 \tag{A.30}$$

has to change instantaneously at the change of the charge q . The usual objection to this is that the unit charge cannot be changed, and the introduction of the additional charge is tied with another process, which is described quite differently. Nevertheless, the mathematical description should still presume the presence of retarded potential, and there is no such one in the equations.

Besides this, in these equations the cause-effect relationships should be determined through writing them in form

$$\Phi_e = \oint_s \mathbf{D} \cdot d\mathbf{S} \Leftarrow q \tag{A.31}$$

and also

$$D \Leftarrow q / 4\pi R^2 \tag{A.32}$$

The fourth equation of Maxwell

$$\text{div} \mathbf{B} = 0 \tag{A.33}$$

and to it corresponding integral equation – the Ostrogradsky-Gauss theorem for magnetic field

$$\Phi_M = \oint_s \mathbf{B} \cdot d\mathbf{S} = 0 \tag{A.34}$$

do not cause much objections, except, perhaps, their deficiencies/flaws as they also assume some static, and besides that there is also absence of time factor. The fourth differential Maxwell's equation is also without any justification placed in the textbooks in the dynamics section. The very same integral form placed in the section of statics expresses the obvious fact that the magnetic lines of force are always closed: as many of them exit the closed surface, that many have to enter it. Time processes are not reflected therein.

In that way, dynamic processes taking place in electromagnetic field are not covered by all four of equations Maxwell, but only by the first and the half of the second one, whereby the first equation does not realistically reflect the process of the formation of EMF in the conductor with the change in time of the magnetic field. The first half of the second Maxwell's equation and the third and fourth equations are the equations of the vortex statics and, in the principle, bear no relation to electrodynamics.

Both the first and second Maxwell's equations ignore the fields outside the contours. However, the adjacent same-directional vortices, having on their peripheries in adjacent areas the medium – ether flows in the opposite directions, effectuate a mutual compensation of fields (Fig. A.2).

That circumstance is not accounted for by the first two equations. If that would be taken into account, then both the electric and magnetic strengths would never be one and the same for the first and the second equations.

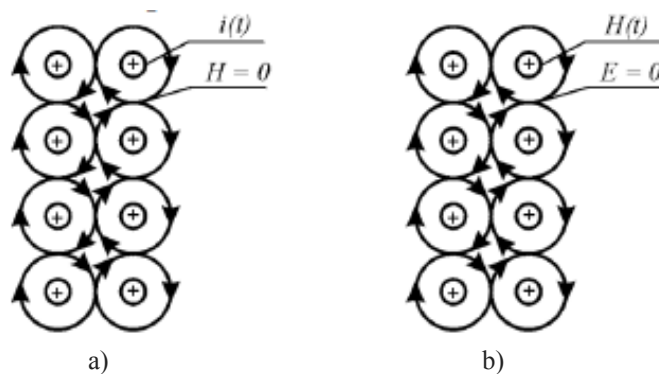

Fig. A.2. Compensation of fields: a — of magnetic field in the system of distributed currents; b — of electric field in the

system of distributed magnetic flows.

Finally, all the Maxwell equations are derived from assumptions about the ideality of the ether and thus imply the absence of viscosity and compressibility. In such ether vortices can neither be formed nor disappear, what does at all not correspond to experimental data: voltages and magnetic fields do arise and disappear, but this is not inherent in the physics of equations. Into the physics of the Maxwell equations is not included the compressibility of fields, directly coming out from the compressibility of ether.

Obtained the Maxwell the electromagnetic field equations based on the hydro-mechanical representations of the electromagnetic phenomena and their many-sided approbation in many practical applications confirm the validity of the method of analogy used by Maxwell, and from there seemingly does not follow the need for any refinement of the equations of electrodynamics. However, these equations being in accordance with the conceptions of Helmholtz on the behavior of vortices in the fluid reflect only the process of vortices moving in space and do not reflect the process of formation of those vortices. In order to consider the process in the whole, there arises the need for attempting additional completions.

In that way, the equations of Maxwell's electrodynamics are not perfect, as nothing is perfect in this world. And therefore they need for working on them to be continued.

Amelioration of Maxwell's equations

1st and 2nd equations

Consider an elementary volume of a medium put under influence of the EMF provided and also of external magnetic fields (Fig. A.3).

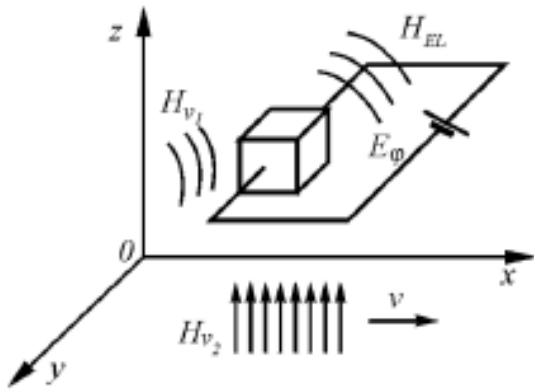

Fig. A.3. Formation of electric current in a medium.

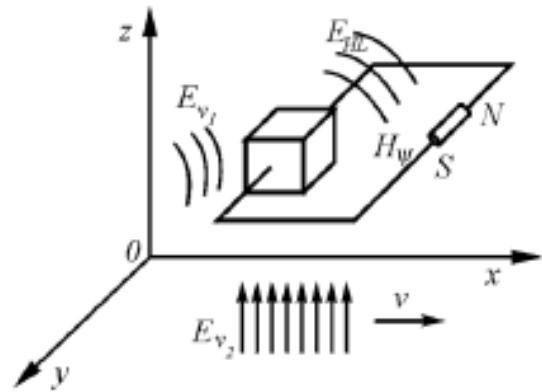

Fig. A.4. Formation of magnetic current in a medium

From the model of the electric field it follows that the current is the result of electric tension/voltage acting in the circuit, and the magnetic field around the conductor is the result of an ordering orientation of electric charges in the circuit. For a medium element within the circuit three electric tensions have to be accounted for, being added with each other and creating an electric current: E_ϕ — tension from an external EMF source; E_{Hv1} — tension induced by other time-varying currents, external to the volume; it should also be noted that the magnetic field that creates that EMF itself has a wave (time-varying?) nature; E_{Hv2} — tension induced by a source moving relative to the considered volume.

The current density δ_e arising in the circuit is determined by those electric tensions (voltages) and the conductivity of the medium. In turn, the current causes a magnetic field, the intensity of which is equal to H_{EL} , so that

$$\text{rot } H_{EL} \leftarrow \delta_e = \left(\sigma E_\phi + \epsilon \epsilon_0 \sum_{i=1}^n \frac{\partial E_i}{\partial t} \right) \quad (\text{A.35})$$

where $\sum_{i=1}^n \frac{\partial E_i}{\partial t}$ is vector sum of time derivatives of electric field tensions (voltages) in the point at which the induced

intensity of the magnetic field \mathbf{H}_{EL} is determined. (In this particular case, $n=2$, $\mathbf{E}_1 = \mathbf{E}_{Hv1}$ and $\mathbf{E}_2 = \mathbf{E}_{Hv2}$.)

Analogously, when considering the elementary volume of the medium, being under the influence of an externally applied MMS ('magneto-motoric force'), and also under the influence of external magnetic fields (Fig. A.4), one obtains:

$$\text{rot} \mathbf{E}_{HL} \Leftarrow \delta_M = -\mu\mu_0 \sum_{i=1}^n \frac{\partial \mathbf{H}_i}{\partial t}, \quad (\text{A.36})$$

where $\sum_{i=1}^n \frac{\partial \mathbf{H}_i}{\partial t}$ is vector sum of time derivatives of magnetic field tensions (intensities?) in the point at which the induced tension (intensity?) of the electric field \mathbf{E}_{HL} is determined. (In this particular case, $n=2$, $\mathbf{H}_1 = \mathbf{H}_{Ev1}$ and $\mathbf{H}_2 = \mathbf{H}_{Ev2}$.)

It needs to be remarked that the exploited analogy is not strictly correct and has to be subsequently confirmed experimentally.

In absence of electric and magnetic sources moving relative to the considered volume, the equations are converted to the following form

$$\text{rot} \mathbf{H}_\Psi \Leftarrow \delta_e = \left(\sigma + \varepsilon\varepsilon_0 \frac{\partial}{\partial t} \right) (\mathbf{E}_\varphi + \mathbf{E}_{Hv1}) \quad (\text{A.37})$$

$$\text{rot} \mathbf{E}_\varphi \Leftarrow \delta_M = -\mu\mu_0 \frac{\partial}{\partial t} (\mathbf{H}_\Psi + \mathbf{H}_{Ev1}). \quad (\text{A.38})$$

These equations represent the modified first and second Maxwell's equations, being different from the latter ones in that in Maxwell's equations usually used "external current" is expressed through tensions (voltages?!?), and also with accounting for sources of electric and magnetic fields, external to the considered volume. Presented in such a modified form the electromagnetic equations allow for making certain conclusions which differ from the usual ones.

Indeed, in general case the intensities of magnetic and electric fields utilized in both equations are different, and not equal as it is the case in Maxwell's equations. The intensity of magnetic field \mathbf{H}_Ψ , figuring on the left-hand side of the second equation (the upgraded Maxwell's second equation) figures as a part of all the magnetic tensions/strengths (of the upgraded Maxwell's first equation); the electric field strength \mathbf{E}_φ figuring on the left-hand side of the first equation figures as a part of the whole electric tension of the right-hand side of the (upgraded Maxwell's) second equation.

To show that the produced result is not that trivial one, as it could look like at first glance, consider a particular case in which $\delta_e \neq 0$ while $\mathbf{H}_\Sigma = \mathbf{0}$ and that is the current flows and changes with time while the magnetic field is absent.

Concretely, if the electric field is directed along the z-axis and distributed uniformly in the xy-plane, then

$$\frac{\partial E_{\varphi x}}{\partial y} = 0; \quad \frac{\partial E_{\varphi y}}{\partial x} = 0 \quad (\text{A.39})$$

and, consequently

$$\text{rot} E_{\varphi z} = \frac{\partial E_{\varphi x}}{\partial y} - \frac{\partial E_{\varphi y}}{\partial x} = 0, \quad (\text{A.40})$$

thus

$$\mathbf{H}_\Psi + \mathbf{H}_{Ev1} = \mathbf{0}, \quad (\text{A.41})$$

that is complete compensation of the magnetic field takes place. Then the whole (upgraded Maxwell's) first equation turns to zero, and the second one remains in the previous form.

Analogously, if the magnetic field is directed along the z-axis and uniformly distributed in xy-plane, then

$$\frac{\partial H_{\Psi x}}{\partial y} = 0; \quad \frac{\partial H_{\Psi y}}{\partial x} = 0 \quad (\text{A.42})$$

and, consequently

$$\text{rot } H_{\psi z} = \frac{\partial H_{\psi x}}{\partial y} - \frac{\partial H_{\psi y}}{\partial x} = 0 \quad , \quad (\text{A.43})$$

thus

$$\mathbf{E}_{\varphi} + \mathbf{E}_{Hv1} = 0 \quad (\text{A.44})$$

that is, full compensation of the electric field results. Then the second (upgraded) Maxwell's equation turns to zero, and the first one remains in the previous form.

At each point in space (thus?) resulted a total compensation of fields internal and external to any of the considered volume, although at first glance it comes to a paradoxical situation: in the presence of an alternating electric current the magnetic field is completely absent. Actually, this field gets completely compensated at each point of space, and, if some portion of conductor contour becomes pulled-out, then on the boundaries of that contour (volume?) as well as within that very contour (volume) immediately arises the corresponding magnetic field.

Experimental testing of the expressed assertions did confirm them.

In the experiment there was used the plane, on which there were situated a number of wire circuits connected serially, through which was passed alternating current. The circuits created an alternating (time-varying) magnetic field in the surrounding space. Over those spools' contours the measuring frame was (being) placed, to which was attached measuring device. Switching of the (spools') contours was carried out in such manner that the corresponding contour of wire circuits could sequentially be switched-in.

The experiment showed that with increasing the number of connected-in internal (w.r.t. measuring frame) wire contours the measured EMF grows, and by the further increase of their numbers outside of the measuring frame the EMF starts to decrease (Fig. A.5). This was true for all sizes of frames. Thus the above assertion received experimental confirmation.

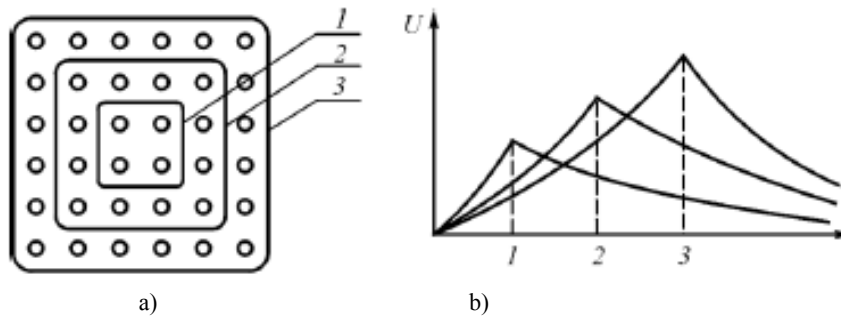

Fig. A.5. Variation of EMF on measuring frames upon the extent of increase in number of switched-in current-carrying contours: a – distribution of measuring contours on the plate with current-carrying spools; b – EMF on measuring frames with increase in number of switched-in current-carrying spools.

It should be noted that the considered problem with time-wise uniformly pulsating fields cannot be solved by Maxwell's equations, because therein electric and magnetic tensions (strengths!?) in both the equations are equal to each other, (and?) also there is no "external currents" here either. To produce the fact of mutual compensation of the components of the field by these equations is difficult. The zero result as the solution of the problem on the basis of Maxwell's equations is possible only if all components of fields and currents are equal to zero, which contradicts the initial conditions of the problem.

The contributed upgraded equations of electrodynamics are almost fully identical to the first two Maxwell's equations if considering the boundary of the in space extending field, provided that outside of this boundary (in the direction of extension) there are no field sources. Then the equations take the form of Maxwell's equations:

$$\text{rot } \mathbf{H}_{\psi} \Leftarrow \delta_e = \left(\sigma + \epsilon \epsilon_0 \frac{\partial}{\partial t} \right) \mathbf{E}_{\varphi} \quad (\text{A.45})$$

$$\text{rot } \mathbf{E}_{\varphi} \Leftarrow \delta_M = -\mu \mu_0 \frac{\partial}{\partial t} \mathbf{H}_{\psi} \quad (\text{A.46})$$

Correspondingly, upgraded can also be the Faraday's induction law

$$e = \oint_l \mathbf{E} \cdot d\mathbf{l} = -S d\mathbf{B}_M / dt \quad (\text{A.47})$$

As such, it takes the form

$$e = \oint_l \mathbf{E} \cdot d\mathbf{l} = -S \left(\frac{d\mathbf{B}_i}{dt} - \frac{d\mathbf{B}_e}{dt} \right) \quad (\text{A.48})$$

whereby for $\mathbf{B}_i = \mathbf{B}_e$, it follows $e = 0$. Indexes “i” and “e” stay for “internal” and “external”.

By analogy with the Faraday law of electromagnetic induction, based on equations of electromagnetic field can be proposed expression for the magnetoelectric induction

$$(\mathbf{H} \cdot \mathbf{l}) = -S[\sigma(\mathbf{E}_i - \mathbf{E}_e) + \epsilon\epsilon_0 \frac{\partial}{\partial t}(\mathbf{E}_i - \mathbf{E}_e)] \quad (\text{A.49})$$

where S — area of a contour that encompasses the current flowing in the medium(?).

Difference to the law of total current here also is manifested in accounting for of the fields outside of the contour(?!).

3rd and 4th equations

Let take in consideration the process of extension/propagation? of the field of electric induction in space (Fig. A.6).

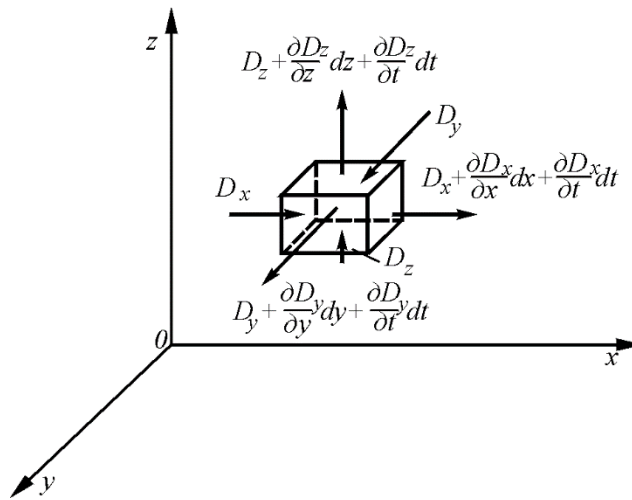

Fig. A.6. Towards deriving equation of extension/distribution? of the electromagnetic induction.

The fact of distribution/extension/propagation of vortex motion of a liquid along the vortex axis allows to formulate the statement/assumption, that the flow of the vortex’s vector, and thus the flow of induction entering certain volume are not equal to the flux/flow of vector, and thus to the flow/flux of electric induction emerging from that volume, whereby the difference will be conditioned/caused by delay(ing)/retardation of the vortex flow/flux along (the)/its axis.

If the flow/flux? of the vector of electric induction \mathbf{D} (originating) from a charge q passes through the surface of a parallelepiped with edges dx, dy, dz , then the flows of vector \mathbf{D} passed through the sides are, respectively, equal to:

through the closer side $D_x dydz$ (A.50); through the far-away side $\left(D_x + \frac{\partial D_x}{\partial x} dx + \frac{\partial D_x}{\partial t} dt \right) dydz$ (A.51)

through the left-hand side $D_y dydz$ (A.52); through the right-hand side $\left(D_y + \frac{\partial D_y}{\partial y} dy + \frac{\partial D_y}{\partial t} dt \right) dx dz$ (A.53)

through the lower side $D_z dx dy$ (A.54); and through the upper side $\left(D_z + \frac{\partial D_z}{\partial z} dz + \frac{\partial D_z}{\partial t} dt \right) dx dy$ (A.55)

By summing the flows through all sides and subsequent dividing by the volume of the parallelepiped, one finds:

$$\left(\frac{\partial D_x}{\partial x} + \frac{\partial D_x}{c_x \partial t} + \frac{\partial D_y}{\partial y} + \frac{\partial D_y}{c_y \partial t} + \frac{\partial D_z}{\partial z} + \frac{\partial D_z}{c_z \partial t} \right) = \rho \quad (\text{A.56})$$

where $c_x = dx/dt$; $c_y = dy/dt$; $c_z = dz/dt$ (A.57)

and thereby
$$\text{div} \mathbf{D} + \frac{\partial D_x}{c_x \partial t} + \frac{\partial D_y}{c_y \partial t} + \frac{\partial D_z}{c_z \partial t} = \rho \quad (\text{A.58})$$

$$\frac{1}{c^2} = \frac{1}{c_x^2} + \frac{1}{c_y^2} + \frac{1}{c_z^2} \quad (\text{A.59})$$

or
$$\text{div} \mathbf{D} + \frac{\partial \mathbf{D}}{c \partial t} = \rho; \quad \mathbf{D} = \mathbf{D} \left(t - \frac{r}{c} \right) \quad (\text{A.60})$$

what differs from the third Maxwell's equation by presence of the factor $\frac{\partial \mathbf{D}}{c \partial t}$ (representing the scalar vector division).

The produced differential equation of the first order for $q=0$ has solution

$$\mathbf{D} = \mathbf{D}(t - r/c) \quad (\text{A.61})$$

i.e. that is a wave, and the very equation – equation of the first order and represents the longitudinal propagation of wave.

The Gauss theorem by that changes somewhat and takes the following form:

$$\Phi_e = \oint_s \mathbf{D}(t - r/c) \cdot d\mathbf{S} = q(t) \quad (\text{A.62})$$

Since the current in the medium propagates along the \mathbf{D} flow and its density δ being proportional to \mathbf{D} , for the current density becomes justified the relationship (in vacuum)

$$\text{div} \rho + \frac{\partial \rho}{c \partial t} = 0; \quad \rho = \rho(t - r/c) \quad (\text{A.63})$$

that is, the propagation/extension?/distribution of the current (density!?) gets the character of a wave.

The given statement contradicts the known static law of Kirchhoff in that the sum of all flows for any point of an electric circuit at any time instant is equaling zero, i.e. that

$$\sum_i^n I_i = 0 \quad (\text{A.64})$$

From (A.52) it follows that the Kirchhoff's law is applicable only on-average, but at any time instant

$$\sum_i^n I_i \neq 0, \quad (\text{A.65})$$

because the wave process (in general) assumes/implies compressibility of the current.

For proving these assertions the experiment has been conducted in accordance with the schematics in Fig. A.8.

It was assumed that on closing the contact on a segment of the conductor, adjacent to it there must occur maximum of current density and, as a consequence, a short voltage pulse. This pulse should decrease in amplitude and broaden in width by increasing distance between the place of its appearance and position of the contact.

Two wires both of several meters in length were connected to a DC voltage source (a conventional battery). To each of the conductors two wire-taps of 1 m in length were attached to them as outlets. The conductors were intermittently closed by the contact. The taps were connected to the high frequency oscilloscope. The goal of the experiment was to determine how the current spreads out through the conductors after closing the circuit, on the separated ends of which the full potential difference is present.

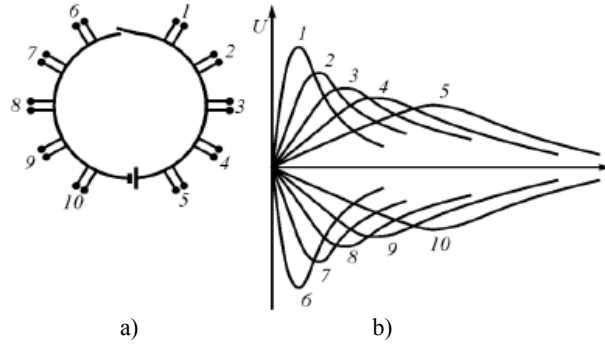

Fig. A.8. Experiment on determination of the current compressibility: a – schematics of conductor tape-offs; b) – impulses appearing on conductor tape-offs.

As a result the experiment revealed that, as expected, after contact is closed at closer to it tape-offs sharp pulses arise of an amplitude nearly the full source voltage while at to it the further-away outlets the impulses are smaller in amplitude, but broader in time. That indicates the compressibility of an electric current in the wire and the wave nature of its distribution. Thus, the compressibility of the current has been factually confirmed.

In difference to electric induction, the magnetic induction in the medium extends perpendicularly to the direction of the (magnetic induction) vector, but the propagation equation will be similar to the propagation equation of electric induction, so that in vacuum:

$$\operatorname{divgrad}\mathbf{B} + \frac{\partial\operatorname{grad}\mathbf{B}}{c\partial t} = 0; \quad (\text{A.66})$$

wherefrom it follows that the very magnetic induction propagates as a wave:

$$\mathbf{B} = \mathbf{B}(t - r/c) \quad (\text{A.67})$$

By accounting for all of this, differential equation of the electromagnetic field take the following form:

$$\operatorname{rot}\mathbf{H}_\psi \Leftarrow \delta_e = \left(\sigma + \varepsilon\varepsilon_0 \frac{\partial}{\partial t} \right) (\mathbf{E}_\varphi + \mathbf{E}_{Hv1} + \mathbf{E}_{Hv2}) \quad (\text{A.68})$$

$$\operatorname{rot}\mathbf{E}_\varphi \Leftarrow \delta_M = -\mu\mu_0 \frac{\partial}{\partial t} (\mathbf{H}_\psi + \mathbf{H}_{Ev1} + \mathbf{H}_{Ev2}) \quad (\text{A.69})$$

$$\operatorname{div}\mathbf{D} + \frac{\partial\mathbf{D}}{c\partial t} = \rho; * \quad (\text{A.70})$$

$$\operatorname{div}\rho + \frac{\partial\rho}{c\partial t} = 0; * \quad (\text{A.71})$$

$$\operatorname{divgrad}\mathbf{B} + \frac{\partial\operatorname{grad}\mathbf{B}}{c\partial t} = 0; * \quad (\text{A.72})$$

Here \mathbf{D} — vector of electric induction, δ_e — vector of electric current density in a medium, \mathbf{B} — vector of magnetic induction. The note that goes along the equations marked by ‘*’ is that division of vectors \mathbf{D} , δ_e , and $\operatorname{grad}\mathbf{B}$ by vector c means that those vectors are collinear, that is they have strictly one and the same direction.

The integral equations take the form

$$e = \oint_l \mathbf{E}(t - r/c) \cdot d\mathbf{l} \Leftarrow -d\Phi_M(t)/dt \quad (\text{A.73}) \quad (\text{A.74})$$

$$e_M = \oint_l \mathbf{H}(t - r/c) \cdot d\mathbf{l} \Leftarrow i(t) - dq(t)/dt$$

$$\Phi_e = \oint_s \mathbf{D}(t - r/c) \cdot d\mathbf{S} \Leftarrow q(t) \quad (\text{A.75}) \quad (\text{A.76})$$

$$\Phi_M = \oint_s \mathbf{B} \cdot d\mathbf{S} = 0$$

Here e and e_M — electric and magnetic potentials difference; Φ_e and Φ_M — electric and magnetic flows (fluxes); i — electric current in conductor; q — charge moving in direction of electric current (directed movement imposes vector form).